



Addendum # 3

Bid Opportunity: 26-7859-RFT

Waterloo-Oxford District Secondary School Window Replacements, Interior Alterations and HVAC Upgrades

Closing Date: Tuesday, April 28, 2026 2:00 PM

The following issued by the Board shall form part of the Bid/ Proposal Solicitation document. The revisions and additions noted herein along with any attachments shall be read in conjunction with all other related documents. This Addendum shall, take precedence over the previously issued documents where differences occur. Receipt of this addendum must be acknowledged in the Bidding System, bids&tenders.

If you have already submitted a Bid/ Proposal, it will be automatically withdrawn as a result of this addendum. You must resubmit the Bid/ Proposal acknowledging all addenda and revising your Bid/ Proposal to comply with all addenda.

3.1 QUESTIONS/ ANSWERS

Question 1:

Can you please clarify what specifically is covered by the Roof-Tie Ins cash allowance?

Answer 1:

This allowance is for tying the roof system into the new HVAC units only.

Question 2:

Which windows are requiring blinds? drawings do not indicate which windows are to receive blinds

Answer 2:

As noted in Specification Section 12 24 13, Article 3.5.1, blinds are required on all new exterior windows. Refer to Drawing A4.01 for illustration of new exterior windows.

Question 3:

Could you please advise on the process and requirements for participating in the tender for this project, including any registration, prequalification, or submission steps?

Answer 3:

This tender is accepting bid submissions from prequalified General Contractors of 7430-RFPQ, by invitation only (based on awarded project size category).

Question 4:

Could we please be provided with structural drawings for us to assess the fireproofing scope of work?

Answer 4:

Structural Drawings S1.01, S2.01 and S2.02 were issued with the Drawing package.

Question 5:

Please clarify if the removal of ductwork will be under a type III operation, since there is asbestos-containing sprayed fireproofing in the school

Answer 5:

ACM trowel-applied fireproofing (3.2% chrysotile) is present in the areas under construction. Duct removal shall be carried out in accordance with Type 2 asbestos operations where disturbance of ACM trowel-applied fireproofing is limited. Where duct removal involves significant disturbance of ACM trowel-applied fireproofing, the work shall be performed as Type 3 operations in accordance with regulatory requirements.

Question 6:

The 2021 asbestos audit shows there is asbestos fireproofing in Corridor 810. The demo drawings call for new fireproofing, but don't mention any removals. Please clarify if the asbestos fireproofing needs to be removed.

Answer 6:

The drawings do not indicate the scope of the asbestos abatement. Bidders are to reference the Asbestos Audit Report for the extent of the asbestos. All asbestos in the Work areas is to be abated.

Question 7:

Addendum 2 states that work in the ground floor classrooms can be conducted during school hours, does that include abatement?

Answer 7:

Refer to Section 01 35 43, Article 1.4.7, for abatement work permitted during school hours.

Question 8:

Can you please confirm within tender documents, if Lockers and or Locker Replacement Fronts are part of this tender.

Answer 8:

No.

Question 9:

- 1) on A4.01, are these the same windows that get the roller shades? And if so, where are they on the other drawing sheets?
- 2) if these are the windows that receive roller shades, what are the expected widths of the individual roller shades? W3 is obvious but W1 and W2 are not.
- 3) are there walls that interrupt the first or 2nd floor bank of windows?
- 4) are these the only windows that receive roller shades?

Answer 9:

- 1) Yes. Floor Plans are found on Drawings A2.01 and A2.03.
- 2) Provide minimum amount required based on mullion layout and width of fabric. Blinds must span from mullion to mullion horizontally if two window units are being grouped together.
- 3) Yes. Refer to Drawings A2.01 and A2.03.
- 4) Yes.

Question 10:

Looking through the spec it looks like the client is providing IKEA cabinets. Is this correct?

Answer 10:

No. Architectural Woodwork is to be construction as indicated in Section 06 40 00, as well as the details that follow this Section.

Question 11:

1. Concrete block sizing is not indicated on any of the openings to be infilled. Can you confirm the size of block to be used?
2. Can you confirm whether the block throughout the building is Imperial or metric?
3. Detail 3 on sheet A4.01 indicates a brick infill. Is this a through penetration that will also require block tooting on the interior. I can't find any other detail on it.

Answer 11:

1. Refer to Note on A2.01. Refer also to Items 3.3.3 and 3.3.4 below.
2. It is imperial. Refer to also to Section 04 22 00.
3. Yes. Refer to Note on Drawing A2.01 for block thickness.

3.2 ARCHITECTURAL SPECIFICATIONS

.1 Section 08 11 16 Aluminum Doors and Frames

.1 ADD the following to Article 1.4.2:

- .4 Windspec Inc.
- .5 Commdoor Inc.

.2 Section 08 44 11 Glazed Aluminum Curtain Walls

.1 ADD the following to Article 1.6.2:

- .4 Windspec Inc.
- .5 Commdoor Inc.

.3 Section 08 80 50 Glazing

.1 ADD Article 2.4.5 as follows:

.5 Privacy window film: as manufactured by Window Film Systems Inc., or approved alternate. Pattern to be selected by Consultant.

.2 ADD Article 3.5 as follows:

3.5 Installation: Privacy Film

- .1 Install film on the interior side of glass units in locations shown on Door and Frame Schedule, in accordance with manufacturer's instructions.
- .2 Film to be installed by professional technicians.

.4 Section 09 30 15 Porcelain Tile

.1 REPLACE Article 2.1.1.1 with the following:

.1 TERRAZZO SERIES, as distributed by Olympia Tile, or approved alternate.

.5 Section 12 24 13 Manually Operated Window Shades

.1 ADD the following to Article 2.1.1:

.3 Moduline 105 Lite-Lift by SunProject.

.4 V-Series Manual by Sun Glow.

.5 Z-300/400 Series by Elite Window Fashions.

3.3 ARCHITECTURAL DRAWINGS

.1 Drawing A0.01 Building Elements, Schedules, OBC Data, Typical Details, Abbreviations & General Notes

.1 REPLACE DRAWING A0.01 WITH DRAWING A0.01R, ATTACHED.

.2 Drawing A0.02 Door Schedule

.1 REPLACE DRAWING A0.02 WITH DRAWING A0.02R, ATTACHED.

.3 Drawing A2.02 Enlarged Floor Plan & Reflected Ceiling Plan

.1 REPLACE DRAWING A2.02 WITH DRAWING A2.02R, ATTACHED.

.4 Drawing A2.03 Enlarged Floor Plans

.1 REPLACE DRAWING A2.03 WITH DRAWING A2.03R, ATTACHED.

.5 Drawing A3.03 Enlarged Roof Plan

.1 REPLACE DRAWING A3.03 WITH DRAWING A3.03R, ATTACHED.

3.4 MECHANICAL/ ELECTRICAL

- .1 REFER TO THE ATTACHED MECHANICAL/ ELECTRICAL ADDENDUM 02 (PART OF THIS ADDENDUM #3) PREPARED BY MNE ENGINEERING LTD. DATED APRIL 16, 2026 (83 PAGES).**

- .2 THIS ADDENDUM CONSISTS OF:**
 - .1 MECHANICAL/ ELECTRICAL SUMMARY OF CHANGES (2 PAGES)**
 - .2 ELECTRICAL SKETCH SK-E01 (1 PAGE)**
 - .5 REVISED SPECIFICATION SECTION 25 90 00 (80 PAGES).**

**END OF ADDENDUM #3
+ Drawings A0.01R, A0.02R, A2.02R, A2.03R, A3.03R;
MECHANICAL/ ELECTRICAL ADDENDUM 02 (83 PAGES).**

WALL ASSEMBLY LEGEND

- NOTES:
 1. THESE WALL TYPES ARE APPLICABLE TO TYPICAL WALL CONDITIONS ON ALL FLOOR PLANS. THERE ARE EXCEPTIONS THAT ARE NOTED/ DETAILED IN THESE DOCUMENTS.
 2. ALL WALL HEIGHTS ARE TO UNDERSIDE OF STRUCTURE ABOVE (BOTTOM CHORD, METAL DECK, ETC.) UNLESS NOTED OR DETAILED OTHERWISE.
 3. WHERE INDICATED ON FLOOR PLAN CONSTRUCTION MATERIALS / WALL ASSEMBLY TO COMPLY WITH REQUIRED FIRE RESISTANCE RATING. JOINTS TO BE SEALED CONTINUOUS AND BE FIRE STOPPED TO PREVENT THE PASSAGE OF SMOKE.
 4. REPAIR EXISTING WALLS WHERE REQUIRED. MAKE GOOD TO RECEIVE NEW MATERIALS AND FINISHES. REFER TO ROOM FINISH SCHEDULE.
 5. WHERE EXISTING WALL CONSTRUCTION IS BEING IN-FILLED WITH NEW WALL CONSTRUCTION, THE FACE OF NEW WALL FINISHES ARE TO ALIGN WITH THE FACE OF THE EXISTING WALL FINISHES.
 6. ALL CONCRETE BLOCK WALL FIRE RESISTANCE RATINGS ARE CALCULATED USING OBC SB-2 TABLE 2.1.1. REFER TO THE ULC DESIGN NUMBER OF ALL OTHER PARTITIONS UNLESS NOTED OTHERWISE.

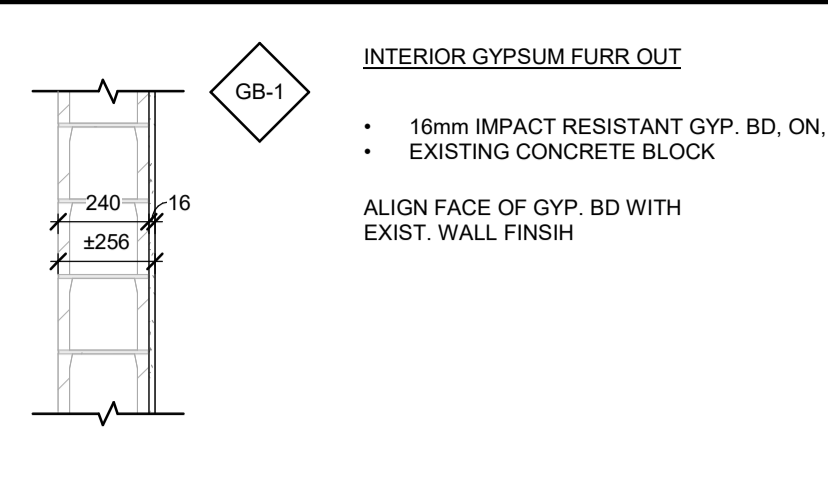
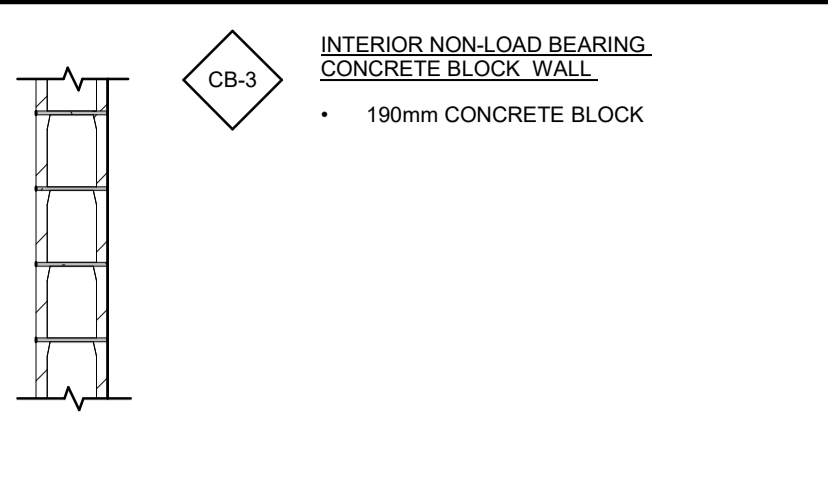
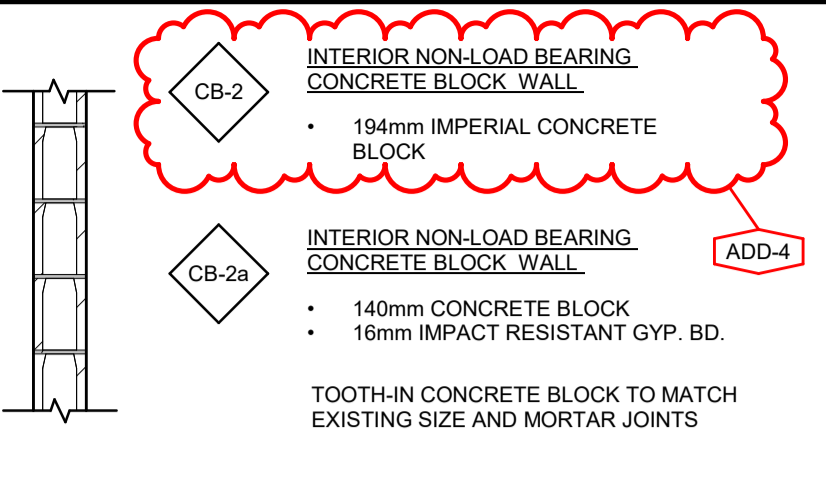
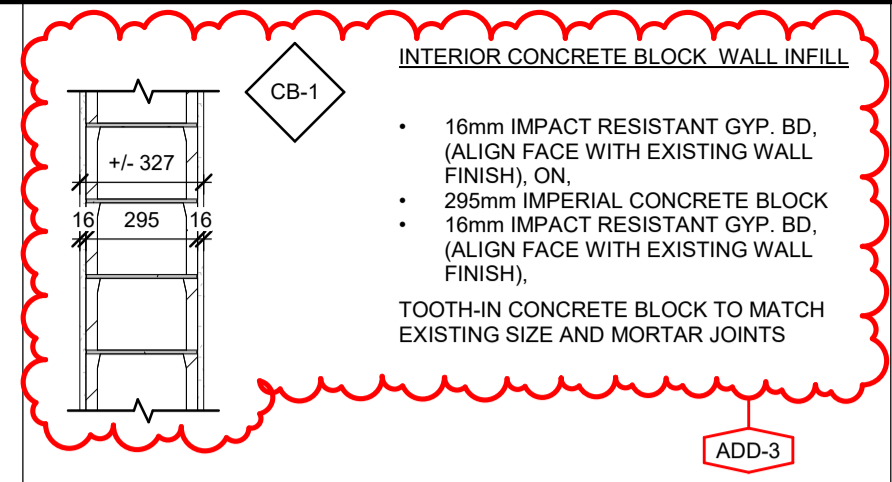

FIRE RESISTANCE RATING CALCULATIONS FOR WALLS CONSTRUCTED OF CONCRETE MASONRY UNITS

REFERENCE OBC SB-2 TABLE 2.1.1.

| TAG | SIZE | TYPE | EQUIV. THICK. | PROVIDED FRR | REQUIRED FRR |
|------|-----------------|------|---------------|--------------|---------------|
| CB-2 | 140 CMU | N | 73mm | 1 HOUR | 30 MIN (MAX.) |
| CB-3 | 190 CMU | N | 95mm | 1.5 HOUR | 30 MIN (MAX.) |
| CB-1 | 240 CMU (EXIST) | N | 113mm | 2.0 HOUR | 30 MIN (MAX.) |

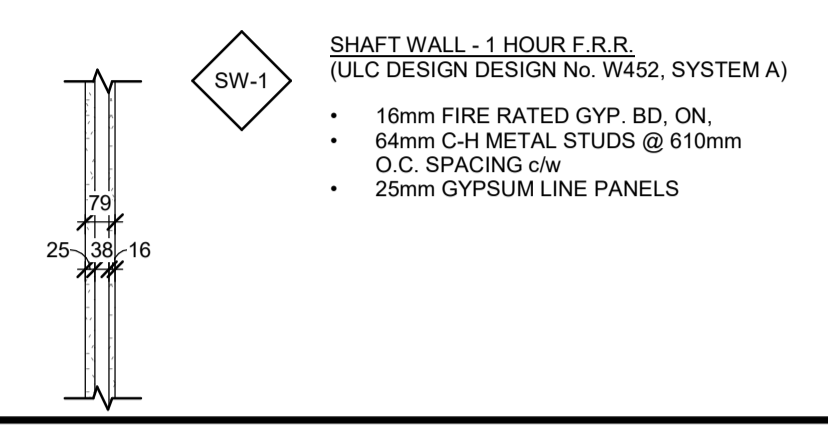
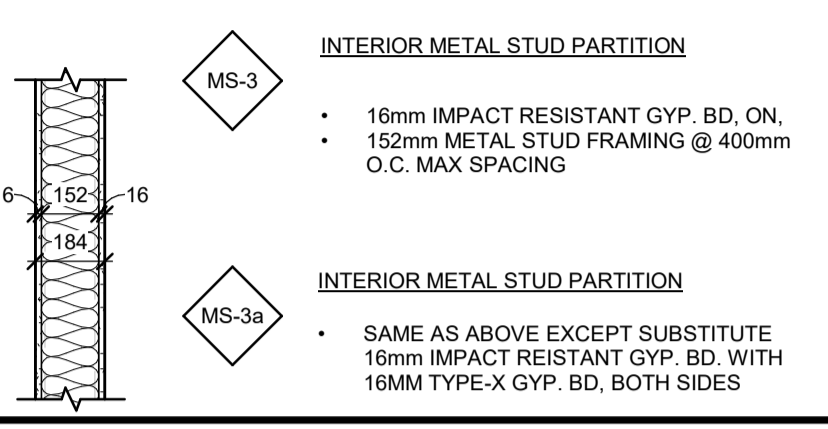
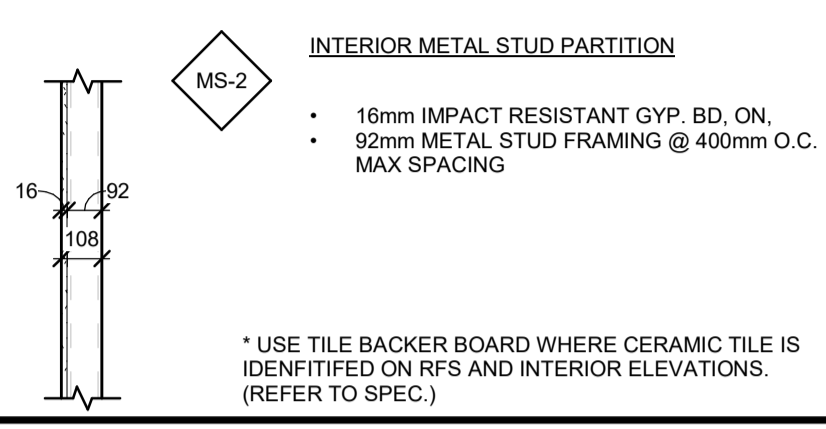
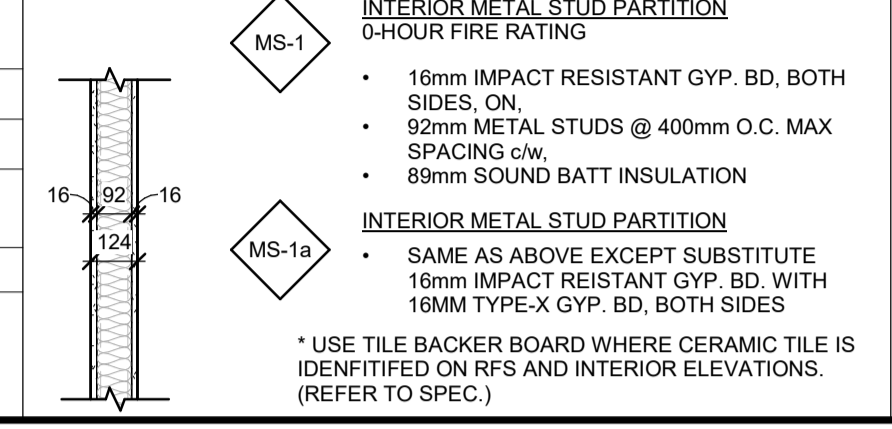

ROOM FINISH SCHEDULE

LEGEND

| ACT1 | ACoustic TILE TYPE 1 | CM | CEILING MATERIAL | EXP | EXPOSED | P | PAINT | WF | WALL FINISH |
|------|----------------------|-------|------------------|-----|----------------|------|--------------------------|----|----------------|
| ACT2 | ACoustic TILE TYPE 2 | CONC. | POURED CONCRETE | FF | FLOOR FINISH | RB | RUBBER BASE | WM | WALL MATERIAL |
| CB | CONCRETE BLOCK | CT | CERAMIC TILE | FM | FLOOR MATERIAL | RSF | RESILIENT SHEET FLOORING | - | NOT APPLICABLE |
| CF | CEILING FINISH | EX | EXISTING | GB | GYPSUM BOARD | TERR | TERRAZZO | - | NOT APPLICABLE |

- NOTES:
 1. COORDINATE THIS SCHEDULE WITH REFLECTED CEILING PLAN, INTERIOR ELEVATIONS, AND FLOOR PLANS.
 2. PAINT BOTH SIDES OF ALL NEW AND EXISTING METAL DOORS AND FRAMES ON ALL WALLS RECEIVING NEW PAINT FINISH. COLOUR TO BE SELECTED BY THE ARCHITECT.
 3. ONLY PAINT EXISTING PAINTED SURFACES ON WALLS TO RECEIVE NEW PAINT FINISH.
 4. ALL CEILINGS NOTED TO BE EXPOSED (EXP) ARE TO BE PAINTED ENTIRELY INCLUDING DUCTWORK, PIPING, CONDUIT, STRUCTURE, METAL DECK, SPRAY APPLIED FIRE PROOFING, ETC. COLOUR TO BE SELECTED BY THE ARCHITECT.
 5. TOOTH-IN NEW BLOCK AND PATCH AND REPAIR PLASTER/GWB FINISH WHERE ELECTRICAL FITURES ARE REMOVED & PAINT AS REQUIRED.
 6. WHERE EXISTING RADIATORS ARE TO REMAIN, PAINT EXISTING RADIATOR COVERS.

| NO. | ROOM NAME | FLOOR | | | | NORTH | | | | EAST | | | | SOUTH | | | | CEILING | | REMARKS |
|--|--------------------|-------|-----|------|-------|-------|----|----|----|------|----|----|----|-------|------|----|--|---|--|---------|
| | | FM | FF | BASE | WM | WF | WM | WF | WM | WF | WM | WF | WM | WF | CM | CF | | | | |
| FIRST FLOOR | | | | | | | | | | | | | | | | | | | | |
| 313 | DRY STORAGE | EX | ESF | ESF | EX | P | EX | P | EX | P | EX | P | EX | P | ACT2 | - | | | | |
| 314 | BULK STORAGE | EX | ESF | ESF | EX | P | EX | P | EX | P | EX | P | EX | P | ACT2 | - | | | | |
| 315 | STORAGE ROOM | EX | ESF | ESF | EX | P | EX | P | EX | P | EX | P | EX | P | GB | P | | | | |
| 315A | WASHROOM | EX | ESF | ESF | EX | P | EX | P | EX | P | EX | P | EX | P | GB | P | | | | |
| 316 | REFRIGERATOR | EX | ESF | ESF | EX | P | EX | P | EX | P | EX | P | EX | P | GB | P | | | | |
| 317 | KITCHEN | EX | ESF | ESF | EX | P | EX | P | EX | P | EX | P | EX | P | ACT2 | - | | | | |
| 317A | DIETICIAN | EX | ESF | ESF | EX | P | EX | P | EX | P | EX | P | EX | P | ACT2 | - | | | | |
| 319 | SERVERY | EX | PT | PT | EX | P | EX | P | EX | P | EX | P | EX | P | ACT2 | - | | PRESSURE WASH ALL EXISTING BLOCK WALLS. | | |
| 320 | DISHWASHING | EX | ESF | ESF | EX | P | EX | P | EX | P | EX | P | EX | P | ACT2 | - | | | | |
| 501 | CLASSROOM | EX | RSF | RB | EX | P | EX | P | EX | P | EX | P | EX | P | ACT1 | - | | PAINT NEW GB BULKHEAD | | |
| 502 | GUIDANCE | EX | EX | EX | EX | P | EX | P | EX | P | EX | P | EX | P | ACT1 | - | | | | |
| 503 | CLASSROOM | EX | RSF | RB | EX | P | EX | P | EX | P | EX | P | EX | P | ACT1 | - | | PAINT NEW GB BULKHEAD | | |
| 504 | LEADERSHIP RM | EX | EX | EX | EX | P | EX | P | EX | P | EX | P | EX | P | ACT1 | - | | | | |
| 504A | STORAGE | EX | EX | EX | EX | P | EX | P | EX | P | EX | P | EX | P | ACT1 | - | | | | |
| 504B | RADIO | EX | EX | EX | EX | P | EX | P | EX | P | EX | P | EX | P | ACT1 | - | | | | |
| 505 | CLASSROOM | EX | RSF | RB | EX | P | EX | P | EX | P | EX | P | EX | P | ACT1 | - | | PAINT NEW GB BULKHEAD | | |
| 506 | CLASSROOM | EX | RSF | RB | EX | P | EX | P | EX | P | EX | P | EX | P | ACT1 | - | | | | |
| 507 | CLASSROOM | EX | RSF | RB | EX | P | EX | P | EX | P | EX | P | EX | P | ACT1 | - | | PAINT NEW GB BULKHEAD | | |
| 810 | CORRIDOR | EX | EX | EX | EX | P | EX | P | EX | P | EX | P | EX | P | ACT1 | - | | | | |
| 819 | STORAGE | EX | ESF | ESF | EX | P | EX | P | EX | P | EX | P | EX | P | GB | P | | | | |
| 819 | CORRIDOR | EX | ESF | ESF | EX | P | EX | P | EX | P | EX | P | EX | P | ACT2 | - | | | | |
| 819A | ELEC. | EX | EX | EX | EX | P | EX | P | EX | P | EX | P | EX | P | ACT2 | - | | | | |
| FIN FLR SECOND FLR OVER SHOP WING | | | | | | | | | | | | | | | | | | | | |
| 520 | WASHROOMS | EX | PT | PT | GB | P | GB | CT | GB | CT | GB | CT | GB | CT | EX | GB | | NORTH WALL: PATCH & REPAIR EXIST. WALL AS REQUIRED AND PAINT. | | |
| 520A | WR | EX | PT | PT | EX/GB | CT | GB | CT | GB | CT | GB | CT | GB | CT | GB | P | | | | |
| 520B | WR | EX | PT | PT | GB | CT | GB | CT | GB | CT | GB | CT | GB | CT | GB | P | | | | |
| 520C | WR | EX | PT | PT | GB | CT | GB | CT | GB | CT | GB | CT | GB | CT | GB | P | | | | |
| 520D | B.F. WR | EX | PT | PT | GB | CT | GB | CT | EX | CT | GB | CT | GB | CT | GB | P | | | | |
| 520E | B.F. WR | EX | PT | PT | GB | CT | GB | CT | EX | CT | GB | CT | GB | CT | GB | P | | | | |
| 520F | WR | EX | PT | PT | GB | CT | GB | CT | GB | CT | EX | CT | GB | CT | GB | P | | | | |
| 520G | WR | EX | PT | PT | GB | CT | GB | CT | GB | CT | EX | CT | GB | CT | GB | P | | | | |
| 520H | WR | EX | PT | PT | EX/GB | CT | GB | CT | GB | CT | EX | CT | GB | CT | GB | P | | | | |
| 559 | CUST. ELEC. | EX | ESF | ESF | GB | P | EX | P | EX | P | GB | P | EX | P | EX | - | | PAINT EXPOSED STRUCTURE | | |
| 560 | RESOURCE | EX | RSF | RB | GB | P | EX | P | GB | P | GB | P | GB | P | ACT1 | - | | | | |
| 561 | OFFICE | EX | RSF | RB | EX | P | EX | P | GB | P | GB | P | GB | P | ACT1 | - | | PAINT NEW GB BULKHEAD | | |
| 1966 TO SECOND FLOOR | | | | | | | | | | | | | | | | | | | | |
| 521 | COMPUTER CLASSROOM | EX | RSF | RB | EX | P | EX | P | EX | P | EX | P | EX | P | ACT1 | - | | PAINT NEW GB BULKHEAD | | |
| 522 | CLASSROOM | EX | RSF | RB | EX | P | EX | P | EX | P | EX | P | EX | P | ACT1 | - | | PAINT NEW GB BULKHEAD | | |
| 523 | COMPUTER CLASSROOM | EX | RSF | RB | EX | P | EX | P | EX | P | EX | P | EX | P | ACT1 | - | | PAINT NEW GB BULKHEAD | | |
| 524 | CLASSROOM | EX | EX | EX | EX | P | EX | P | EX | P | EX | P | EX | P | ACT1 | - | | PAINT NEW GB BULKHEAD | | |
| 525 | COMPUTER CLASSROOM | EX | RSF | RB | EX | P | EX | P | EX | P | EX | P | EX | P | ACT1 | - | | PAINT NEW GB BULKHEAD | | |
| 526 | CLASSROOM | EX | EX | EX | EX | P | EX | P | EX | P | EX | P | EX | P | ACT1 | - | | PAINT NEW GB BULKHEAD | | |
| 527 | CLASSROOM | EX | RSF | RB | EX | P | EX | P | EX | P | EX | P | EX | P | ACT1 | - | | PAINT NEW GB BULKHEAD | | |
| 528 | CLASSROOM | EX | EX | EX | EX | P | EX | P | EX | P | EX | P | EX | P | ACT1 | - | | PAINT NEW GB BULKHEAD | | |
| 823 | CORRIDOR | EX | EX | EX | EX | P | EX | P | EX | P | EX | P | EX | P | ACT1 | - | | PAINT NEW GB BULKHEAD | | |

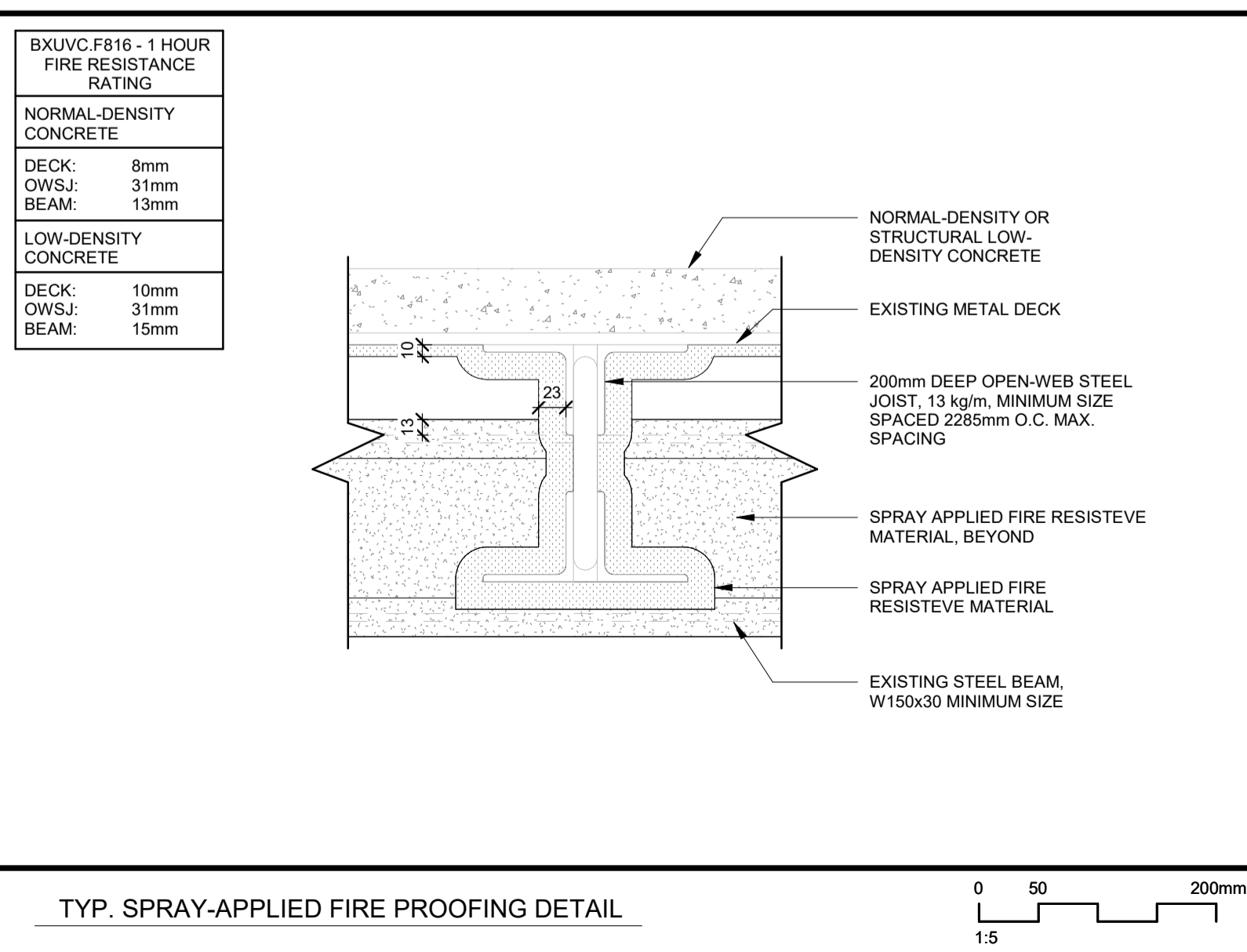
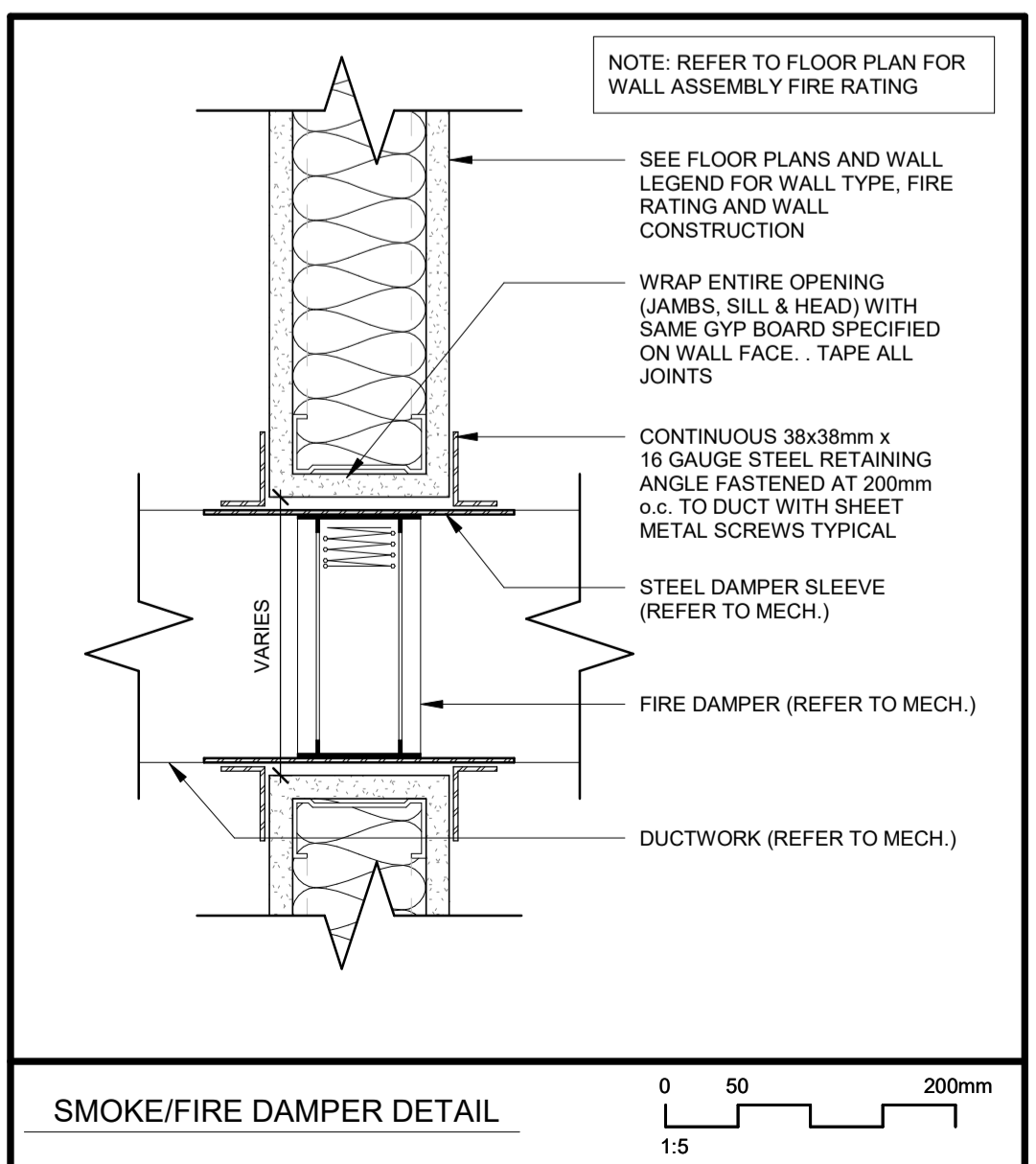

ABBREVIATIONS

NOTES, LEGENDS, & ABBREVIATIONS ARE APPLICABLE TO ALL DRAWINGS

| ABBREVIATION | DESCRIPTION | ABBREVIATION | DESCRIPTION | ABBREVIATION | DESCRIPTION |
|--------------|-----------------------|--------------|----------------------------|--------------|-----------------------------|
| AFF | ABOVE FINISHED FLOOR | EXIST | EXISTING | O.C | ON CENTRE |
| ALUM | ALUMINUM | EXT | EXTERIOR | PDO | POWER DOOR OPERATOR |
| ARCH | ARCHITECTURAL | FEX | FIRE EXTINGUISHER | PREFIN | PREFINISHED |
| ACT | ACoustic CEILING TILE | F | FRIDGE (OWNER SUPPLIED) | RFHC | RECESSED FIRE HOSE CABINET |
| A/V | AIR/VAPOUR BARRIER | FG | FLOOR GRILLE | RD | ROOF DRAIN |
| B.F. | BARRIER FREE | FIN | FINISH | RTU | ROOF TOP UNIT |
| BLKHD | BULKHEAD | GB | GRAB BAR | RWL | RAIN WATER LEADER |
| CB | CONCRETE BLOCK | GMWB | GLASS MAT GYPSUM BOARD | SND | SANITARY NAPKIN DISPENSER |
| CLG | CEILING | GYP BD | GYPSUM BOARD | SPEC | SPECIFICATIONS |
| CONC | CONCRETE | HM | HOLLOW METAL | STL | STEEL |
| CONT | CONTINUOUS | INSUL | INSULATION | STRUC | STRUCTURAL |
| c/w | COMPLETE WITH | LKR | LOCKER | T/O | TOP OF |
| D | DRYER | MECH | MECHANICAL | TTD | TOILET TISSUE DISPENSER |
| DA | DIAMETER | MFG | MANUFACTURER | TV | TELEVISION (OWNER SUPPLIED) |
| D.F. | DRINKING FOUNTAIN | MICRO | MICROWAVE (OWNER SUPPLIED) | TWF | THROUGH WALL FLASHING |
| DW | DISH WASHER | MIN | MINIMUM | TYP | TYPICAL |
| DWG | DRAWING | MIRR | MIRROR | U/S | UNDERSIDE |
| ECS | EMERGENCY CALL SYSTEM | mm | MILLIMETRES | VCT | VINYL COMPOSITE TILE |
| ELEC | ELECTRICAL | mw | MILLWORK | W | WASHING MACHINE |
| EP | ELECTRICAL PANEL | N.I.C | NOT IN CONTRACT | w | WITH |

GENERAL NOTES

- THIS LEGEND IS APPLICABLE TO ALL DRAWINGS
- CONTRACTOR TO VERIFY DIMENSIONS ON SITE AND REPORT ALL DISCREPANCIES TO THE ARCHITECT PRIOR TO PROCEEDING.
 - REFER TO FLOOR PLANS FOR FIRE SEPARATION LOCATIONS. CARRY ALL PARTITIONS TO UNDERSIDE OF STRUCTURAL METAL DECK UNLESS NOTED OR DETAILED OTHERWISE.
 - FIRE STOP ALL JOINTS AND PENETRATIONS IN FIRE SEPARATIONS.
 - INTERIOR DIMENSIONS ARE FROM FACE OF WALL FINISH TO FACE OF WALL FINISH.
 - ALL CONCRETE BLOCK TO BE LIGHT WEIGHT.
 - PROVIDE SOLID WOOD BLOCKING BEHIND ALL WASHROOM AND SERVERY ACCESSORIES & DOOR HARDWARE IN METAL STUD PARTITIONS.
 - INFILL ALL EXISTING MECHANICAL OPENINGS WITH NEW BLOCK TO MATCH EXISTING. COORDINATE WITH MECHANICAL DEMOLITION PLANS.
 - USE MOISTURE RESISTANT GMWB IN ALL WASHROOMS, SHOWER ROOMS, AND KITCHEN AREAS.
 - ALL INTERIOR CONCRETE BLOCK CORNERS TO BE BULLNOSED. TYPICAL AT ALL LOCATIONS UNLESS NOTED OTHERWISE.
 - ALL WALLS TO BE CONSTRUCTED AS 0-HOUR FIRE SEPARATIONS UNLESS NOTED OTHERWISE.
 - ALL PARTITIONS TO CARRY OVER OPENINGS UNLESS NOTED OTHERWISE.
 - CONTRACTOR TO RESTORE ALL AREAS DISTURBED BY CONSTRUCTION.
 - TOOTH-IN NEW MASONRY UNITS WITH EXISTING MASONRY UNITS. MASONRY UNIT SIZE AND JOINTS TO MATCH EXISTING MASONRY UNITS.
 - ALL DOORS INSTALLED 100mm FROM WALL ON HINGE SIDE UNLESS DETAILED OTHERWISE.

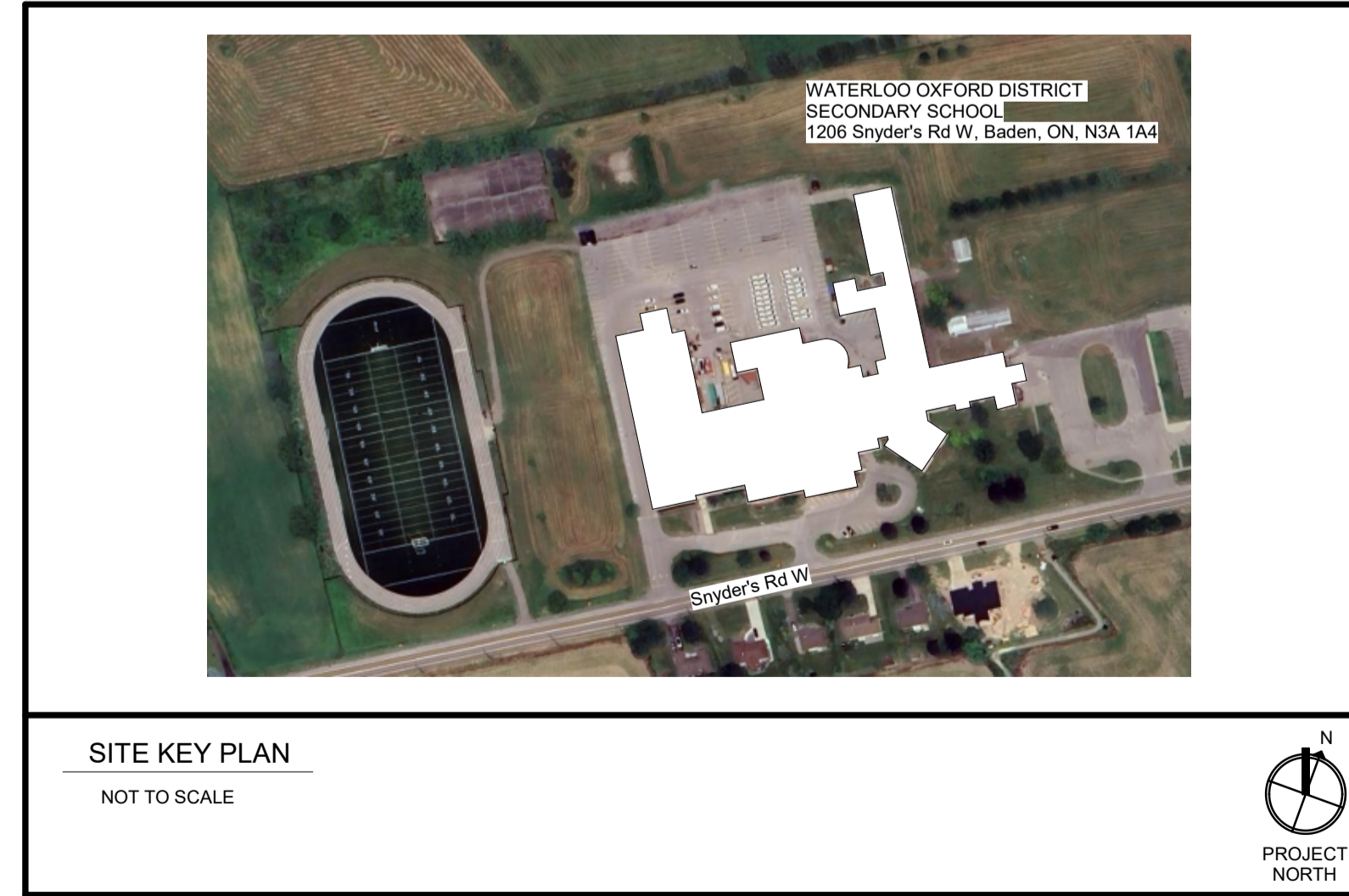

Name of Practice: Cornerstone Architecture Incorporated
 1102-320 Thames Street London, ON N6A 0E1
 tel (519) 432-6644 fax (519) 432-6737

Certificate of Practice No. 2677
 Name of Project: Waterloo Oxford District Secondary School
 Project Location: 1206 Snyder's Road, Baden, ON, N3A 1A4

| ITEM | DESCRIPTION | O.B.C. REFERENCE |
|------|---|----------------------|
| 01 | Project Type: <input type="checkbox"/> New <input type="checkbox"/> Addition <input checked="" type="checkbox"/> Renovation <input type="checkbox"/> Change Use <input type="checkbox"/> Addition & Renovation | PART 11 [A] 1.1.2 |
| 02 | Description: Interior Renovation | |
| 03 | Major Occupancy (s): Group 'A' - Division 2 - Assembly Occupancy, School | 3.2.2.24 |
| 03 | Building Area (m ²): Second Floor: Existing: 3,887 m ² New: 0 m ² Total: 3,887 m ² Ground Floor: Existing: 12,003 m ² New: 0 m ² Total: 12,003 m ² Port-A-Pack: Existing: 717 m ² New: 0 m ² Total: 717 m ² | [A] 1.4.1.2 |
| 04 | Gross Area: Existing: 16,007 m ² New: 0 m ² Total: 16,007 m ² | |
| 05 | Number of Storeys: Above Grade: 2 Below Grade: 0 Height of Building (m): ±9.05 m (Existing) | [A] 1.4.1.2, 3.2.1.1 |
| 06 | Number of Streets / Fire Fighters Access Routes: 3 (Existing) | 3.2.2.10 & 3.2.5 |
| 07 | Building Classification: Renovated: 3.2.2.24 Group A Division 2, up to 6 Storeys Existing: 3.2.2.25 Group A Division 2, up to 2 Storeys | 3.2.2.20 - 83 |

DOOR & FRAME SCHEDULE

LEGEND

| | | | | | | | | | |
|----|----------------|----|-----------------|------|------------------------|-----|---------------------|------|----------------|
| DE | DOOR ELEVATION | FD | FRAME DETAIL | FRR | FIRE RESISTANCE RATING | P | PAINT | TEMP | TEMPERED |
| DF | DOOR FINISH | FE | FRAME ELEVATION | H | HEIGHT | PDO | POWER DOOR OPERATOR | W | WIDTH |
| DM | DOOR MATERIAL | FF | FRAME FINISH | HM | HOLLOW METAL | S&V | STAIN AND VARNISH | WD | WOOD |
| EX | EXISTING | FM | FRAME MATERIAL | min. | MINUTE | T | THICKNESS | - | NOT APPLICABLE |

NOTES:
1. SITE CONFIRM DIMENSIONS OF ALL NEW DOORS AND FRAMES

| NO. | SIZE | DOOR | | | GLASS | LABEL (FRR) | FRAME | | | | HARDWARE | | | REMARKS |
|--------------------------|---------------|------|------|------|-------|-------------|-------|------|------|------|----------|--------|------|---|
| | | DE | DM | DF | | | FE | FD | FM | FF | HANDLE | CLOSER | LOCK | |
| SHOP FLOOR | | | | | | | | | | | | | | |
| 901-1 | 2x915x2134x50 | DE-3 | ALUM | ANOD | INSUL | | FE-4 | FD-4 | ALUM | ANOD | PULL | YES | YES | PDO |
| 901-2 | 2x915x2134x50 | DE-3 | ALUM | ANOD | INSUL | | FE-4 | FD-4 | ALUM | ANOD | PULL | YES | YES | PDO |
| (1962) TO SHOP ROOF DECK | | | | | | | | | | | | | | |
| 520A-1 | 860x2134x45 | DE-1 | HM | P | TEMP | | FE-1 | FD-2 | HM | P | LEVER | NO | YES | PROVIDE WINDOW FILM ON TRANSOM ABOVE DOOR |
| 520B-1 | 860x2134x45 | DE-1 | HM | P | TEMP | | FE-1 | FD-2 | HM | P | LEVER | NO | YES | PROVIDE WINDOW FILM ON TRANSOM ABOVE DOOR |
| 520C-1 | 860x2134x45 | DE-1 | HM | P | TEMP | | FE-1 | FD-2 | HM | P | LEVER | YES | YES | PROVIDE WINDOW FILM ON TRANSOM ABOVE DOOR |
| 520D-1 | 950x2134x45 | DE-1 | HM | P | TEMP | | FE-1 | FD-2 | HM | P | LEVER | YES | YES | PROVIDE WINDOW FILM ON TRANSOM ABOVE DOOR |
| 520E-1 | 950x2134x45 | DE-1 | HM | P | TEMP | | FE-1 | FD-2 | HM | P | LEVER | YES | YES | PROVIDE WINDOW FILM ON TRANSOM ABOVE DOOR |
| 520F-1 | 860x2134x45 | DE-1 | HM | P | TEMP | | FE-1 | FD-2 | HM | P | LEVER | NO | YES | PROVIDE WINDOW FILM ON TRANSOM ABOVE DOOR |
| 520G-1 | 860x2134x45 | DE-1 | HM | P | TEMP | | FE-1 | FD-2 | HM | P | LEVER | NO | YES | PROVIDE WINDOW FILM ON TRANSOM ABOVE DOOR |
| 520H-1 | 860x2134x45 | DE-1 | HM | P | TEMP | | FE-1 | FD-2 | HM | P | LEVER | NO | YES | PROVIDE WINDOW FILM ON TRANSOM ABOVE DOOR |
| 559-1 | 965x2134x45 | DE-1 | HM | P | | 3/4 HR | FE-1A | FD-1 | HM | P | LEVER | YES | YES | |
| 560-1 | 950x2134x45 | DE-2 | HM | P | TEMP | | FE-2 | FD-1 | HM | P | LEVER | YES | YES | |
| 561-1 | 950x2134x45 | DE-2 | HM | P | TEMP | | FE-3 | FD-1 | HM | P | LEVER | YES | YES | |

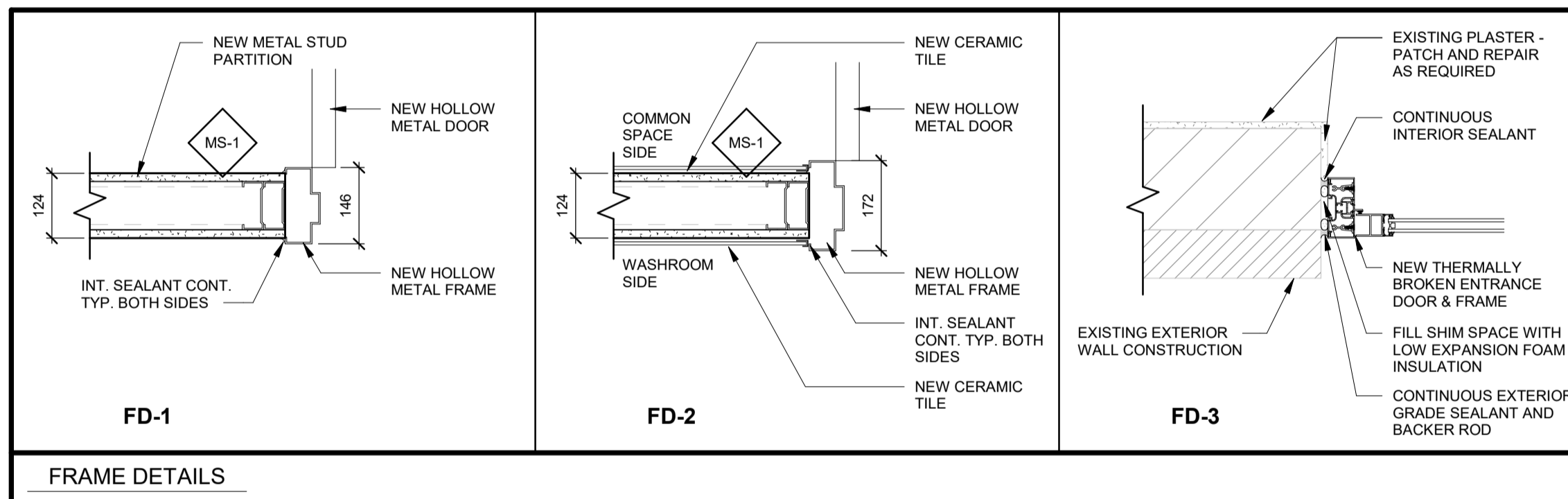
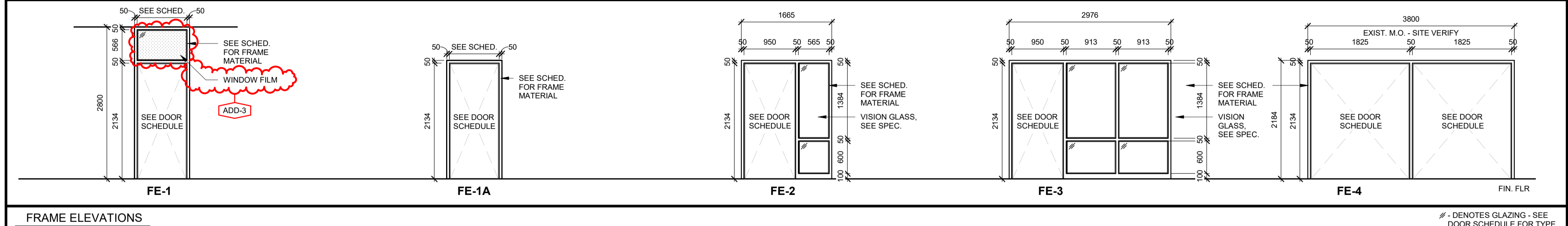
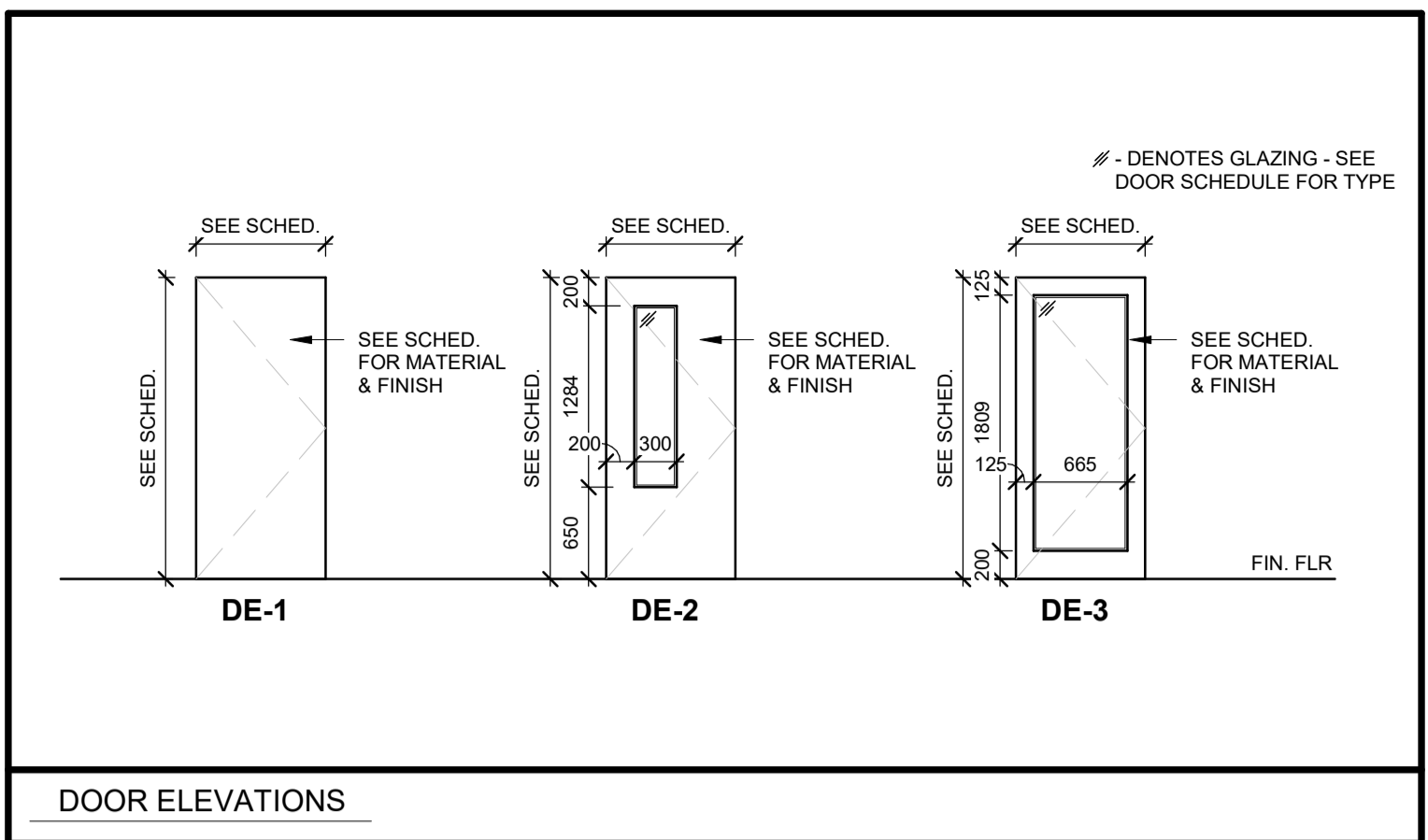

100-520 Thames Street, London, Ontario N6A 0E1
P: 519 432 6644 F: 519 432 6737
cornerstonearchitecture.ca

© 2025 Cornerstone Architecture Incorporated. All Rights Reserved.

CORNERSTONE
ARCHITECTURE

ISSUED FOR BID
ISSUED FOR PERMIT
ISSUED FOR ADDENDUM 03

2024-03-27
2024-03-30
2025-04-24



Waterloo-Oxford District Secondary School
WINDOW REPLACEMENTS, INTERIOR ALTERATIONS AND HVAC UPGRADES

1206 Snyder's Rd W, Baden, ON N3A 1A4

Project No.: 1167A
Drawn By: CAI
Pict Date: 2025-04-24

DOOR SCHEDULE

A0.02R

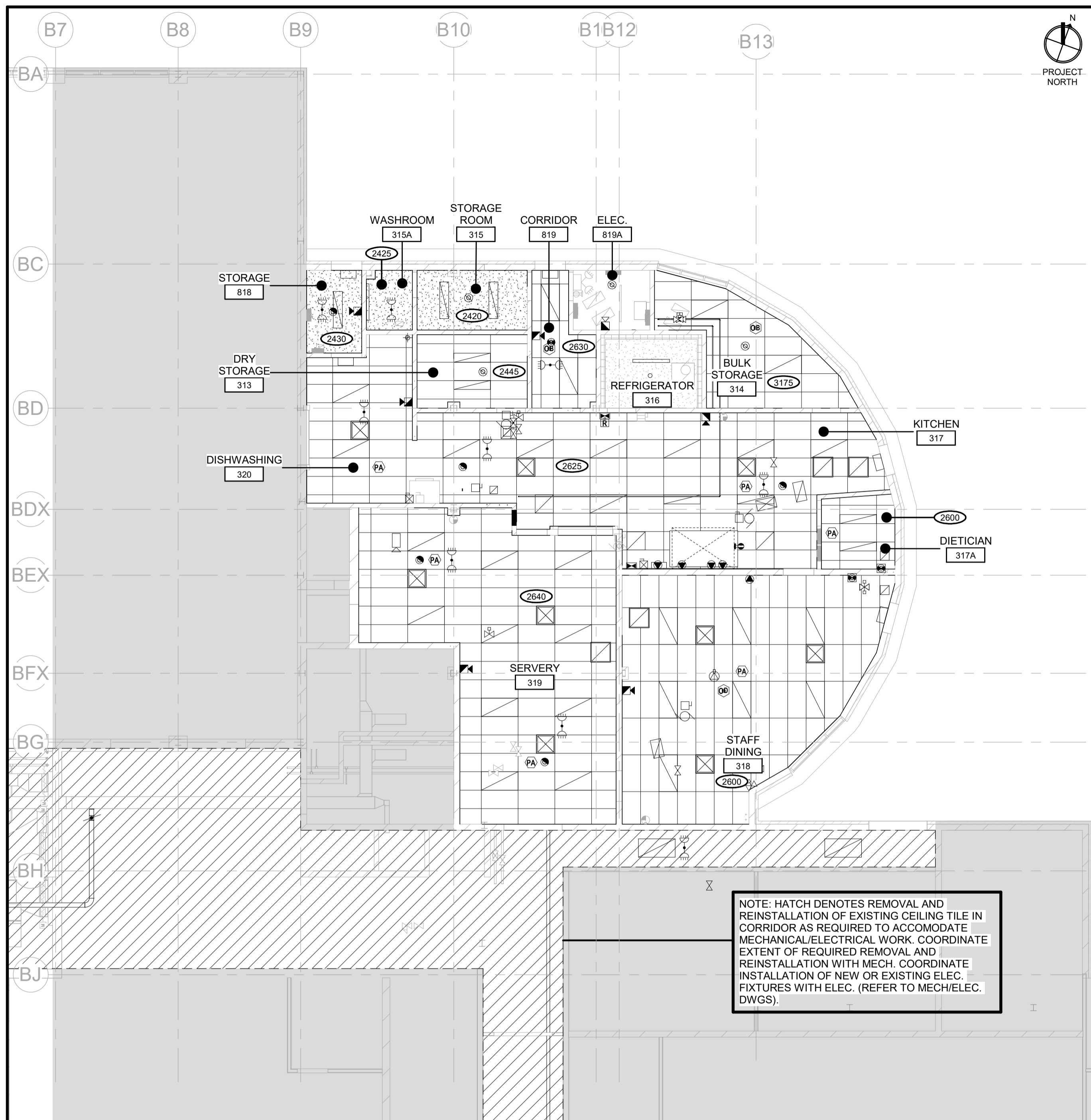
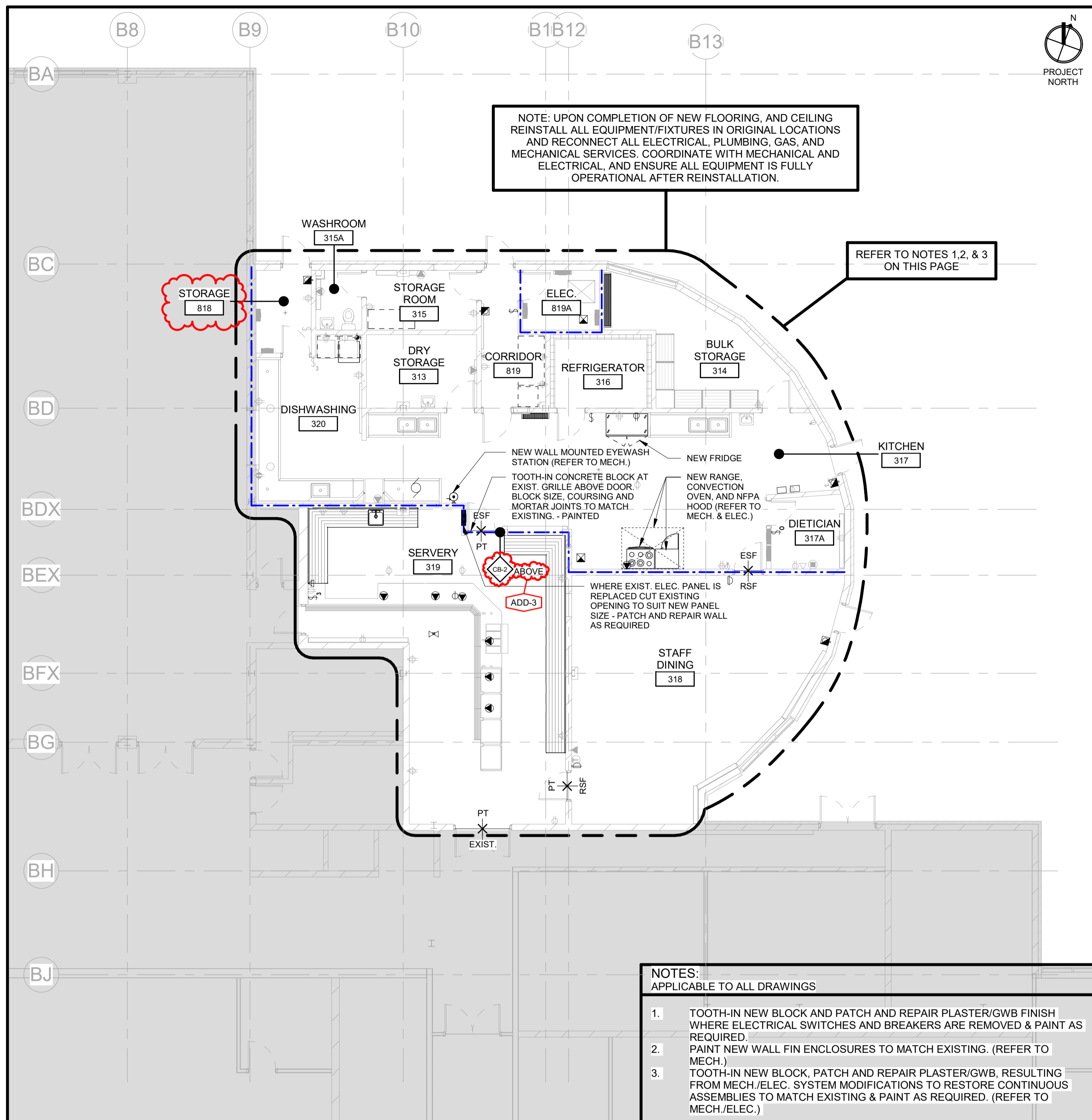

1 ENLARGED GROUND FLOOR - CAFETERIA KITCHEN
A2.02R
0 1 2.5 5 10 m
1:100

2 ENLARGED GROUND FLOOR REFLECTED CEILING PLAN - CAFETERIA KITCHEN
A2.02R
0 1 2.5 5 10 m
1:100

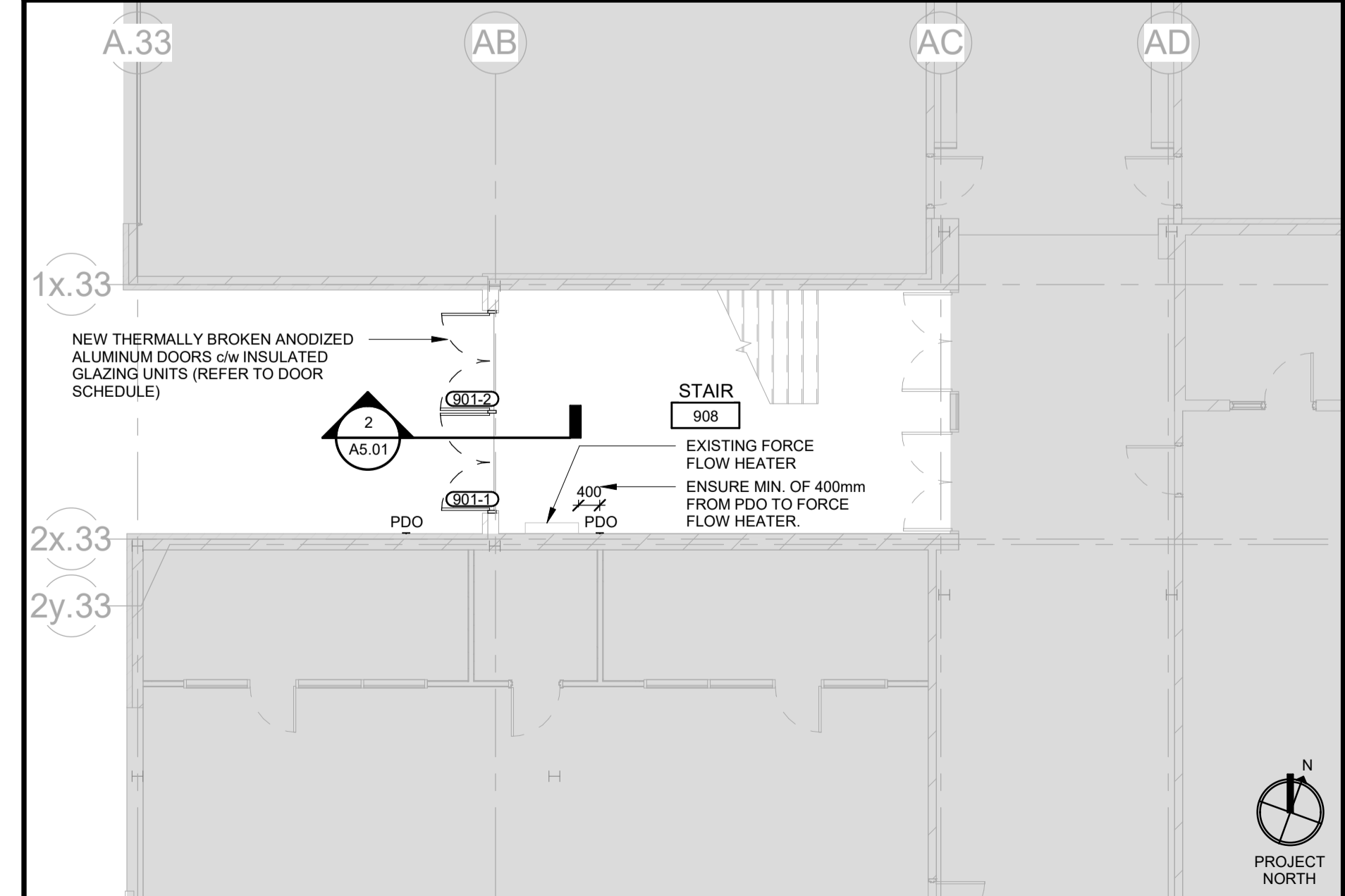
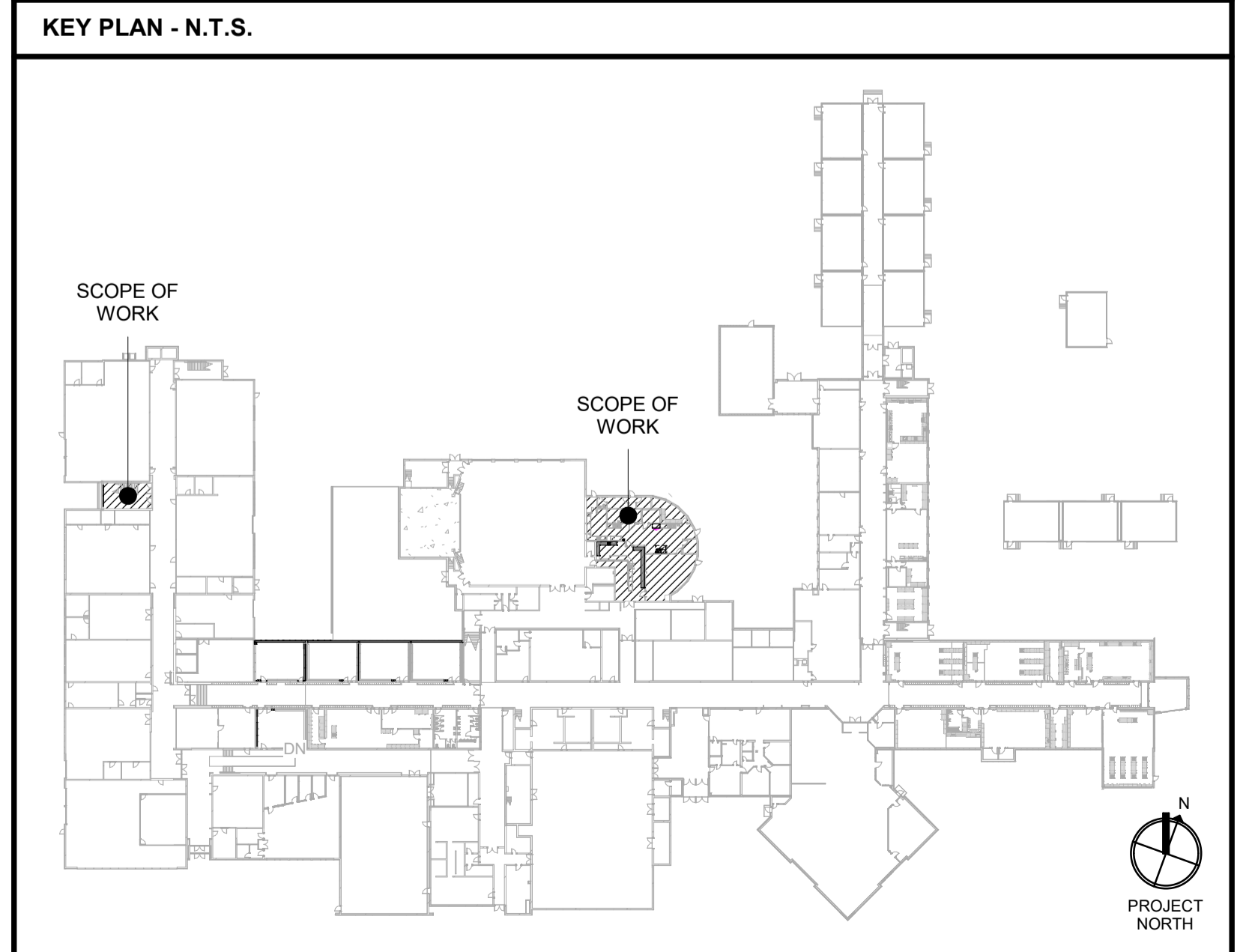

3 ENLARGED GROUND FLOOR PLAN - STAIR 908
A2.02R
0 1 2.5 5 10 m
1:100

105-520 Thames Street, London, Ontario N6A 0E1
P: 519 432 6644 F: 519 432 6737
cornerstonearchitecture.ca

© 2025 Cornerstone Architecture Incorporated. All Rights Reserved.

ISSUED FOR BID
ISSUED FOR PERMIT
ISSUED FOR PERMIT
ISSUED FOR ADDENDUM 03

2024-03-27
2024-03-30
2024-04-16
2024-04-24

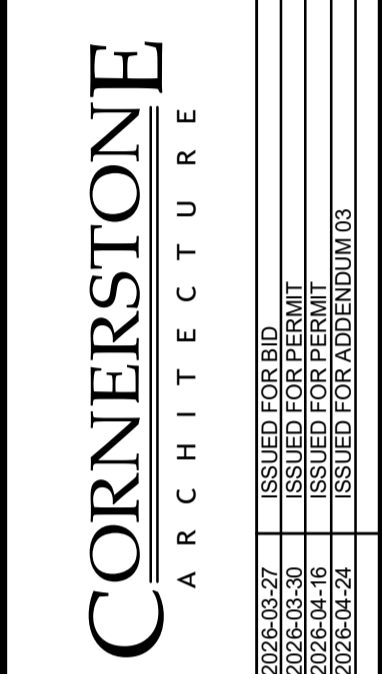

Waterloo-Oxford District Secondary School
WINDOW REPLACEMENTS, INTERIOR ALTERATIONS AND HVAC UPGRADES

1206 Spyrder's Rd W. Baden, ON N3A 1A4

Project No.: 1167A
Drawn By: CAI
Pict Date: 2025-06-24

ENLARGED FLOOR PLAN & REFLECTED CEILING PLAN

A2.02R

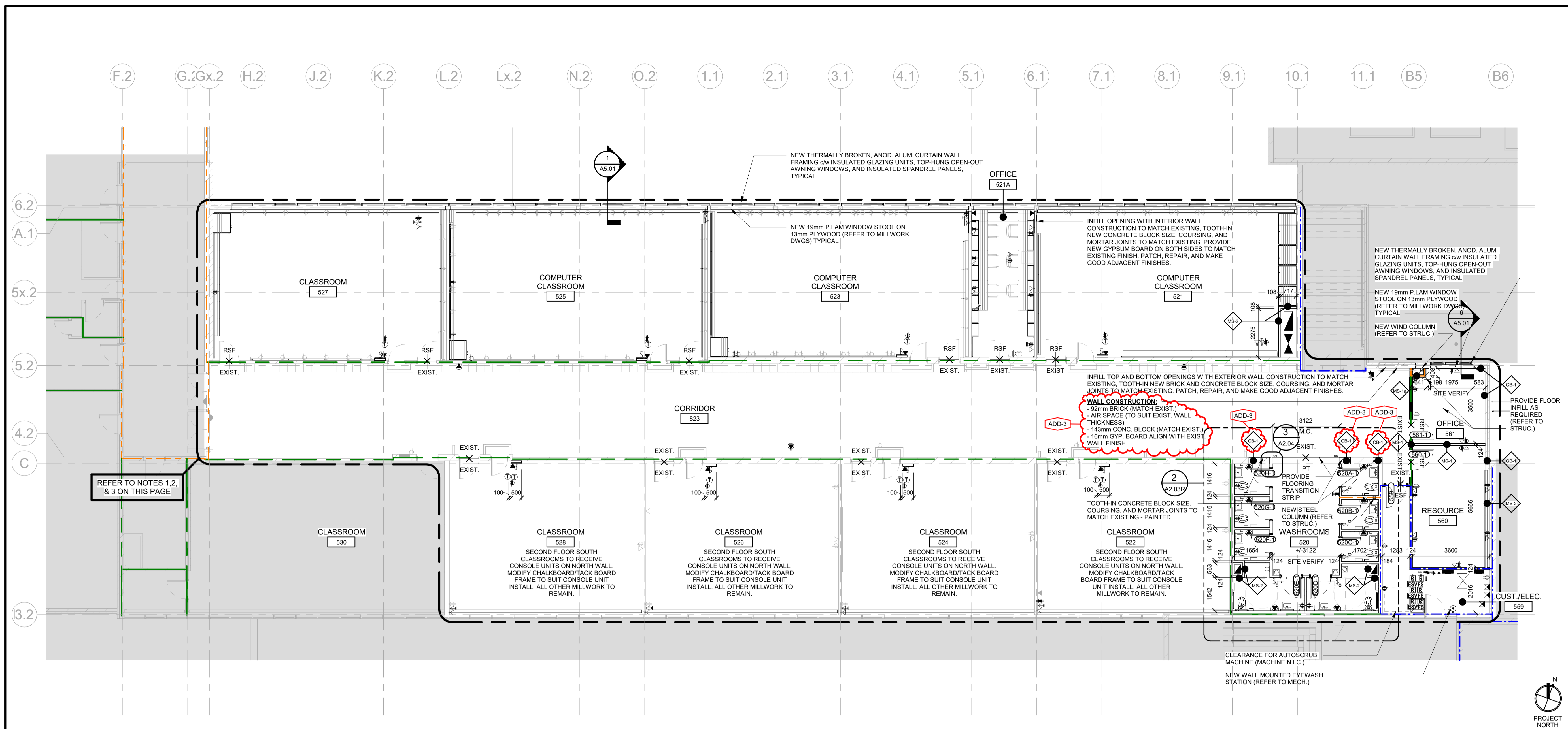

1 ENLARGED SECOND FLOOR PLAN - 500 WING
A2.03R

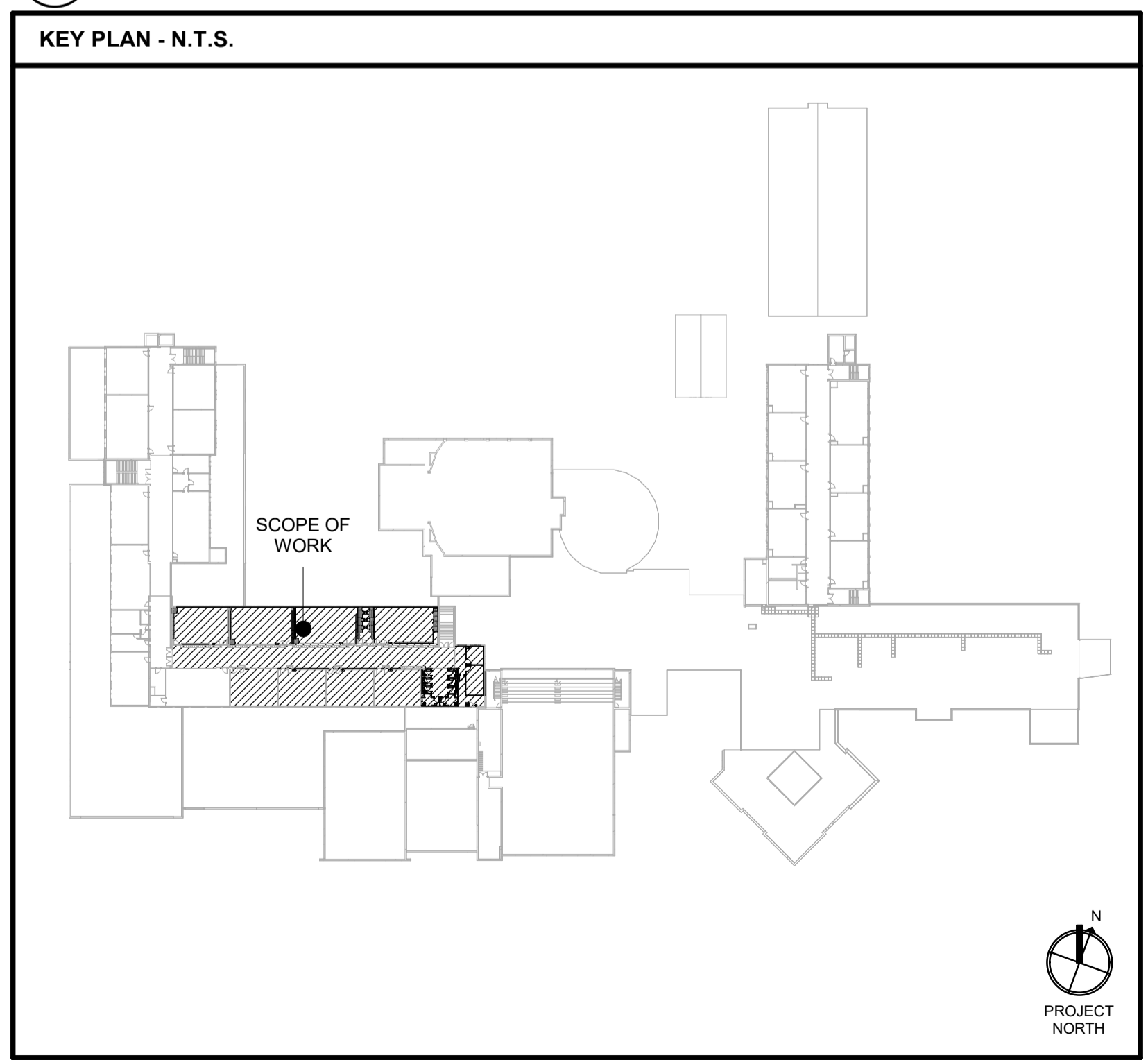

- NOTES:**
APPLICABLE TO ALL DRAWINGS
- TOOTH-IN NEW BLOCK AND PATCH AND REPAIR PLASTER/GWB FINISH WHERE ELECTRICAL SWITCHES AND BREAKERS ARE REMOVED & PAINT AS REQUIRED.
 - PAINT NEW WALL FIN ENCLOSURES TO MATCH EXISTING. (REFER TO MECH.)
 - TOOTH-IN NEW BLOCK, PATCH AND REPAIR PLASTER/GWB, RESULTING FROM MECH./ELEC. SYSTEM MODIFICATIONS TO RESTORE CONTINUOUS ASSEMBLIES TO MATCH EXISTING & PAINT AS REQUIRED. (REFER TO MECH./ELEC.)

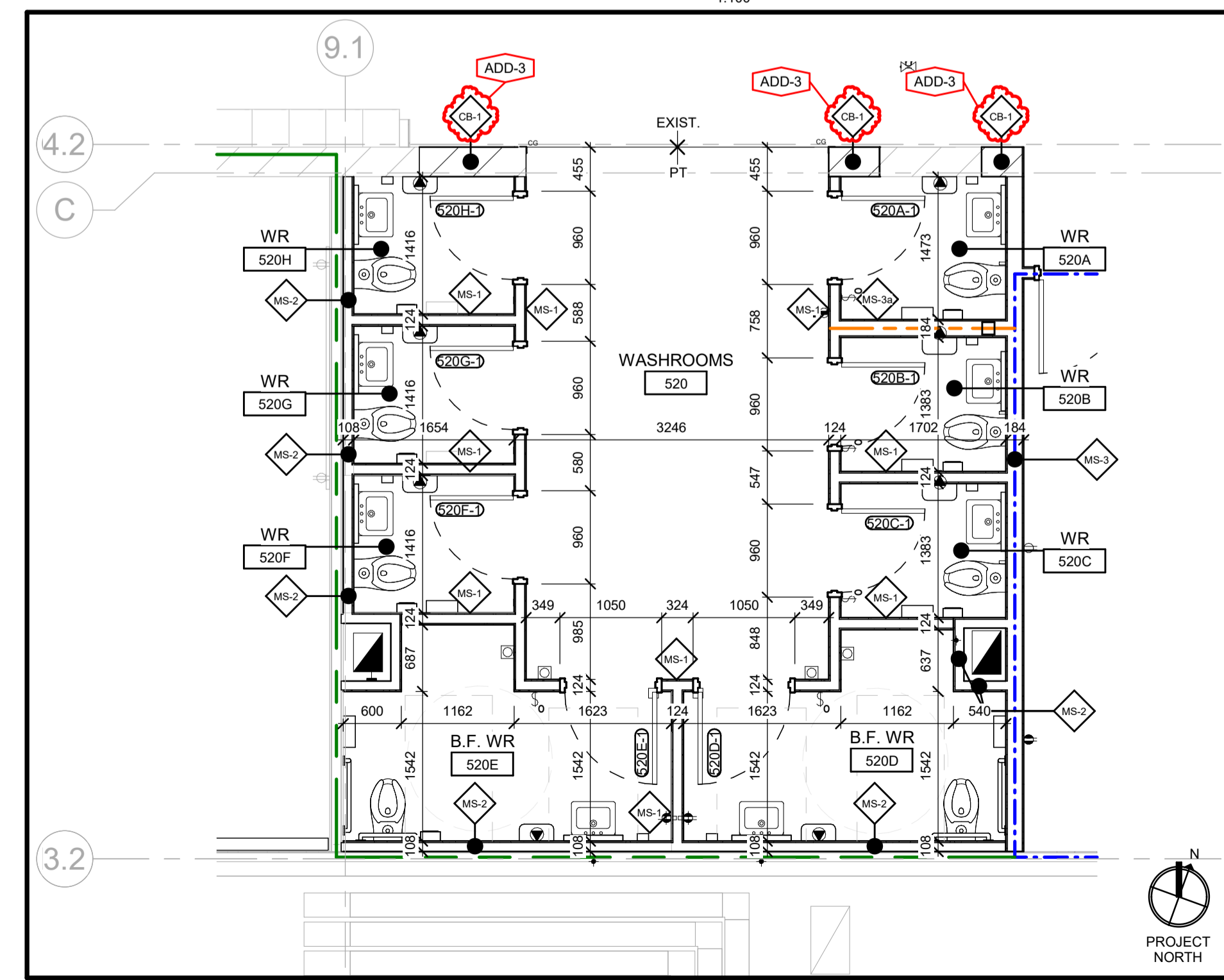

2 ENLARGED SECOND FLOOR PLAN - 500 WING - WASHROOMS
A2.03R

105-520 Thames Street, London, Ontario N6A 0E1
P 519 432 6644 F 519 432 6737
cornerstonearchitecture.ca

CORNERSTONE
ARCHITECTURE

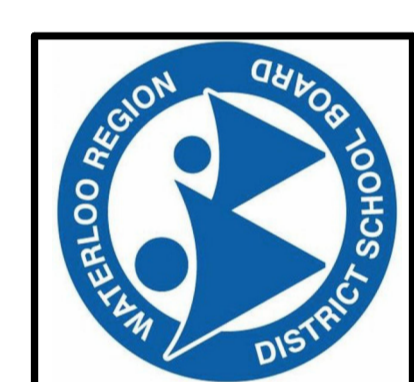

Waterloo-Oxford District Secondary School
WINDOW REPLACEMENTS, INTERIOR ALTERATIONS AND HVAC UPGRADES
ENLARGED FLOOR PLANS

1206 Spynar's Rd W. Baden, ON N3A 1A4
Project No.: 1167A
Drawn By: CAI
Pict Date: 2025-06-24

A2.03R

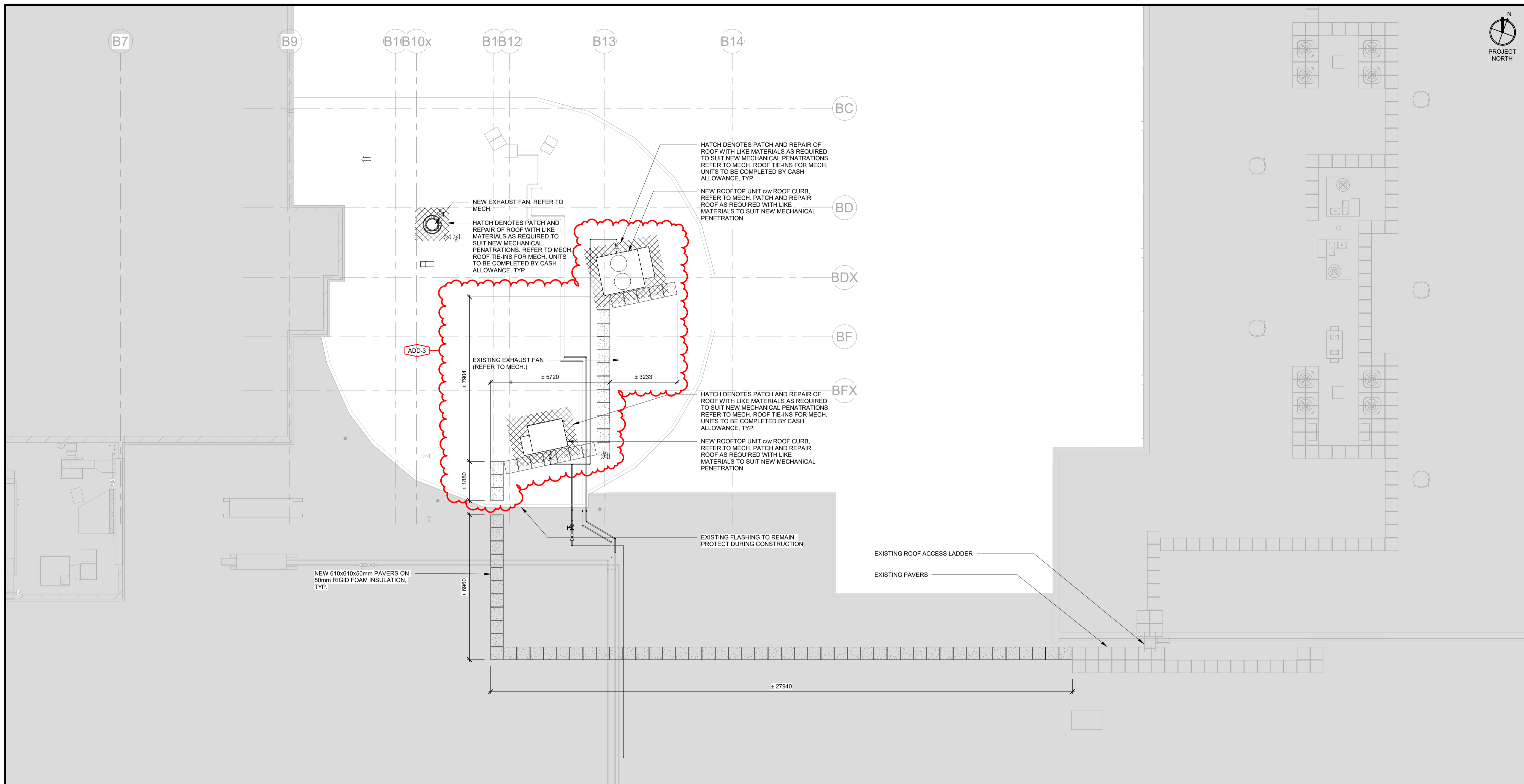

1 ENLARGED ROOF PLAN - CAFETERIA KITCHEN

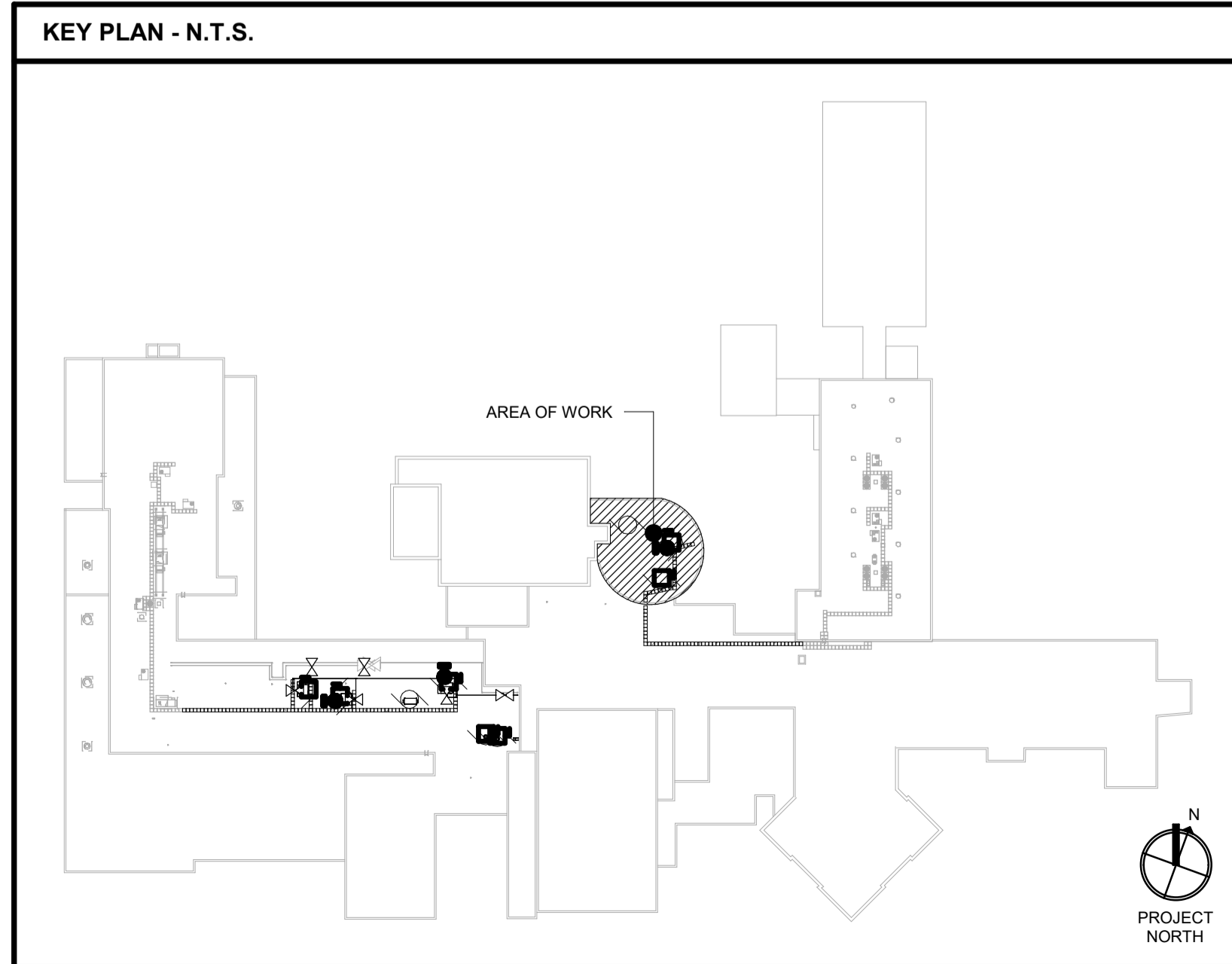

- GENERAL ROOF PLAN NOTES**
1. CONTRACTOR TO VERIFY SITE CONDITIONS AND REPORT ANY DISCREPANCIES TO THE ARCHITECT PRIOR TO PROCEEDING.
 2. CONTRACTOR TO COORDINATE DEMOLITION WITH ASBESTOS AUDIT. REFER TO SPECIFICATIONS.
 3. REFER TO FLOOR PLANS FOR FIRE SEPARATION LOCATIONS.
 4. REFER TO SPECIFICATION FOR ROOF CONSTRUCTION AND PATCHING.
 5. COORDINATE ALL ROOFTOP MECHANICAL EQUIPMENT AND ROOF DRAINS WITH MECHANICAL DOCUMENTS.
 6. PROVIDE CRICKETS AT ALL NEW ROOF EXHAUST LOCATIONS. CONFIRM QUANTITIES WITH MECHANICAL DRAWINGS.
 7. WHERE SLOPED INSULATION IS REQUIRED FOR PATCHING OR CRICKETS, SLOPE TO BE 1.5% MINIMUM.
 8. SITE CONFIRM QUANTITY OF CONCRETE ROOF PAVERS REQUIRED.
 9. CONTRACTOR TO RESTORE ANY ROOF AREAS DISTURBED BY CONSTRUCTION TO EXISTING CONDITION.
 10. CONTRACTOR TO REMOVE AND DISPOSE OF ALL LOOSE DEBRIS ON ROOF.

102-320 Thames Street, London, Ontario N6A 0E1
 P 519 432 6644 F 519 432 6737
 cornerstonearchitecture.ca

© 2025 Cornerstone Architecture Incorporated. All Rights Reserved.

CORNERSTONE
 ARCHITECTURE

ISSUED FOR BID 2025-03-27
 ISSUED FOR PERMIT 2025-03-30
 ISSUED FOR ADDENDUM 03 2025-04-24



Waterloo-Oxford District Secondary School
 WINDOW REPLACEMENTS, INTERIOR ALTERATIONS AND HVAC UPGRADES

ENLARGED ROOF PLAN

Project No.: 1167A
 Drawn By: CAI
 Plot Date: 2025-05-27

A3.03R

ADDENDUM 02

| | | | |
|------------|-------------------------------|--------------------|--|
| To: | Cornerstone Architecture Inc. | Date: | April 16, 2026 |
| | | Project: | Waterloo Oxford District Secondary School Interior Alterations & HVAC Upgrades |
| cc: | WRDSB | Project No: | 26012 |

This addendum forms part of the contract documents and amends the drawings and specifications.

Mechanical

1. Reference Specification
 - a. Add Section 25 90 00 Controls Sequences. Refer to attachment.
2. Reference 1/M3.3
 - a. Add note 13 to read: "Rework heating water piping as required to suit installation of ductwork." Apply note to the following locations:
 - i 100mm heating water supply piping in Corridor 810 outside Classrooms 501, 503, 505, and 507.
 - ii 38mm heating water supply and return piping along south wall in Classroom 501.
 - iii 32mm heating water supply and return piping in northwest corner of Classroom 501.
 - iv 38mm, 32mm and 19mm heating water supply and return piping in southeast corner of Classroom 501.
 - v 32mm heating water supply and return piping along south wall in Classrooms 503 and 505.
 - vi 25mm heating water supply and return piping in northwest corner of Classroom 505.
 - vii 25mm heating water supply and return piping along south wall in Classroom 507.
3. Reference 1/M3.4
 - a. Relocate new 900X350mm supply air ductwork in Corridor 810 to run down the centre of the corridor, in place of the removed exhaust air ductwork, opposed to running along north wall of corridor (reference 1/M2.4 for removed exhaust air ductwork).

Electrical

1. Reference 1/E1.1 & SK-E01
 - a. Delete electrical connections to two pumps in Boiler Room 300.
 - i Delete power/controls & associated wiring/conduit back to source.
 - ii Provide updated lamacoid labels and panel directories at source as required.
 - iii Coordinate with mechanical to confirm pump removals prior to commencing work.
2. Reference Lighting Fixture Schedule on E5.1

i Revise vacancy sensor (\$V) to Lutron MSCL-VP153M. Program for Manual On, Auto Off.

End of Addendum

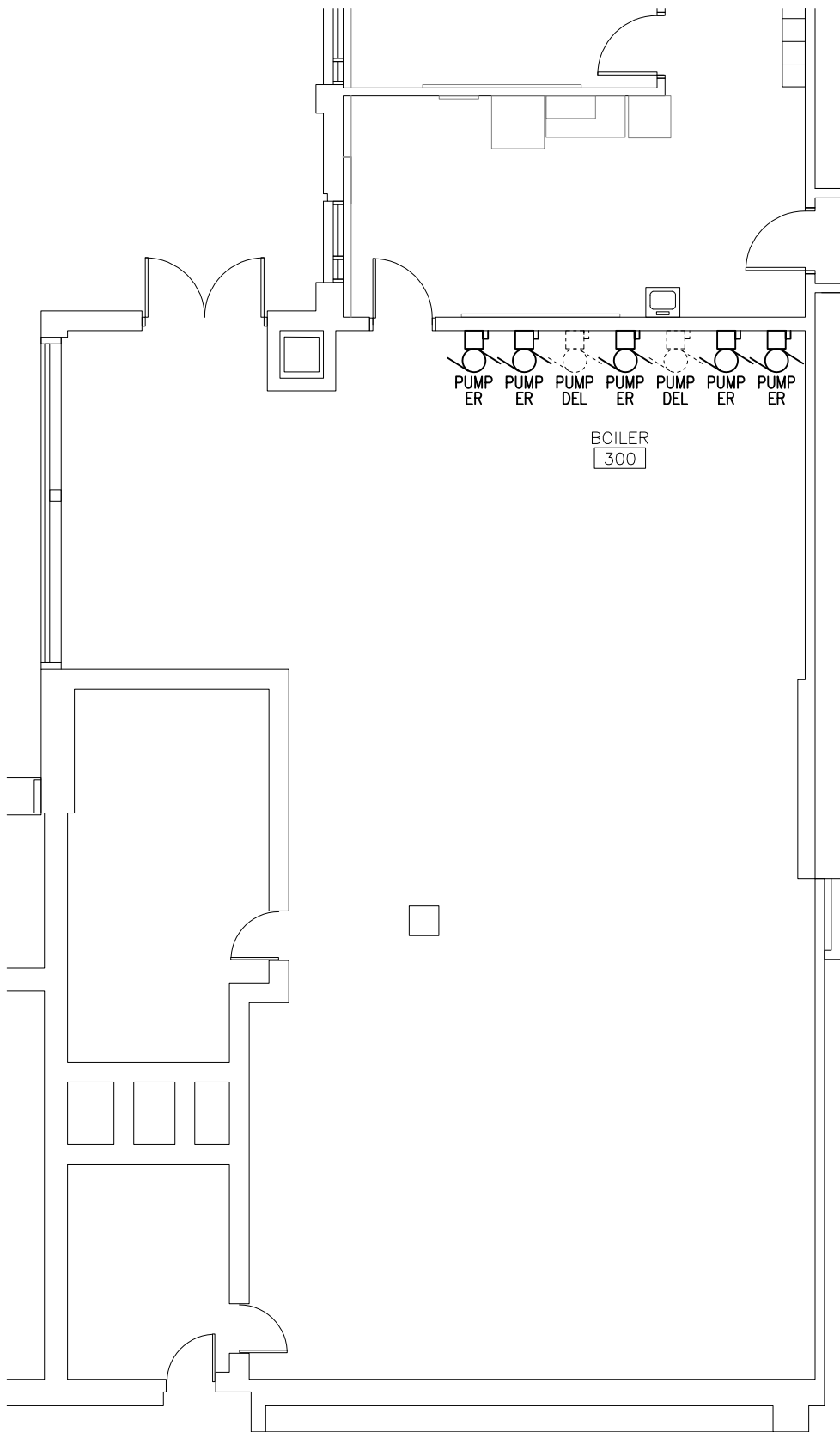

MNE Engineering Inc.
22 Kevco Place – Box A
Kitchener, Ontario N2C 2G5
(519) 894-9408
www.mneengineering.ca

PROJECT: WATERLOO OXFORD DISTRICT SECONDARY SCHOOL

DRAWING: BOILER ROOM ELECTRICAL PLAN

DWG NO: SK-E01

JOB NO: 26012

SCALE: 1:100

DRAWING BY: A.T.

DATE: APRIL 2026

CHECKED BY: C.W.

03

02

01 ADDENDUM 02

REV# REVISION

CLIENT: CORNERSTONE ARCHITECTURE INC.

1. GENERAL

1.1 General Requirements

- .1 Refer to the following related sections:
 - a. Division 20 – Mechanical.
 - b. Division 22 – Plumbing.
 - c. Division 23 – HVAC.
 - d. Section 25 05 00 – INTEGRATED AUTOMATION.
- .2 Comply with the conditions of Division 0 and 1.

1.2 Sequence of Operations

- .1 General:
 - a. All setpoints shall be adjustable.
 - b. Provide BAS sensors for temperature, flow, pressure, electrical current, etc. where indicated on the drawings and where required to perform the sequences specified in this Division.
 - c. Provide control schematics and points list based on sequences in this Division.
 - d. Control description provides intent for BAS controls. Provide programming and control parameters to achieve specified intent.
 - e. Field measure setpoints for air and water systems, where design setpoint is dependent on the field balanced condition.
 - f. Display controlled variables, monitored dependent variables and fixed parameters on relevant equipment graphics.
 - g. Where sensors or other field control devices are indicated on the drawings, provide monitoring points, including feedback for controlled devices, and display on the relevant equipment graphics.
 - h. Monitor status of all controlled equipment and display on equipment graphics. Provide current sensors where status is not available through equipment control interface.
- .2 For sequences of operation, refer to the following:
 - a. Attached WRDSB BAS Master Sequence of Operations
 - b. Equipment schedules on drawings.
 - c. Notes on drawings.

END OF SECTION



WRDSB BAS Master Sequence of Operations

Version 1.0o Updated: November 14, 2024

Table of Contents:

| | |
|--|-----------|
| 1. Integration Requirements | 10 |
| 1.1. Holiday Schedule | 10 |
| 1.2. Global Ventilation Schedule | 10 |
| 1.3. Cooling Enabled Mode | 10 |
| 1.4. Heating Enabled Mode | 10 |
| 1.5. Free Cooling Setpoint Calculation | 11 |
| 1.6. Sample Calculations Tables: | 11 |
| 1.6.1. Humidity-Limited Free Cooling..... | 11 |
| 1.6.2. Outside Air Temperature Limit Free Cooling..... | 11 |
| 1.7. Minimum Outdoor Air Enable Time Schedule: | 11 |
| 1.8. Minimum Outdoor Air Mixing Damper Position Setpoint: | 12 |
| 1.9. Night Setback Heating Setpoint: | 12 |
| 1.10. BAS Designations: | 12 |
| 2. Definitions: | 13 |
| 2.1. Global Functions: | 13 |
| 2.2. Local Functions: | 13 |
| 2.3. Local Mode of Operation: | 14 |
| 2.4. Global Mode of Operation: | 14 |
| 2.5. Server Based Holiday Scheduling | 14 |
| 2.6. Server based Humidity: | 14 |
| 2.7. Server based Heating Reset Setpoints: | 15 |
| 2.8. Server based Astroclock: | 15 |
| 2.9. Fire Alarm Sequence of Operation: | 15 |
| 2.10. Server based Minimum Outdoor Air Damper Position Setpoint: | 15 |
| 2.11. Server based Mechanical Systems Outdoor Air Temperature Enable Setpoints: | 16 |
| 2.12. Server based Zone Temperature Control for Night Setback Heating Setpoints and Setpoint Adjusts: | 16 |
| 2.13. Local System-Based Default Room (Heating) Setpoint | 16 |
| 2.14. Local System-Based Time Schedule | 16 |
| 2.15. Outdoor Air Temperature | 17 |
| 2.16. Optimized Start Program | 17 |
| 2.17. Morning Warmup Mode: | 17 |
| 2.18. Rooftop Heating Stage Sequencing: | 17 |
| 2.19. Rooftop Economizer Sequencing: | 17 |
| 2.20. Rooftop Mechanical DX Cooling Stage Sequencing: | 17 |
| 3. Equipment Specific Sequence of Operations: | 18 |
| 3.1. VVT HVAC Rooftop Unit Sequence of Operations: | 18 |
| 3.1.1. Discretionary Fire Alarm Shutdown Mode:..... | 18 |
| 3.1.2. Software Freeze-stat Shutdown Mode:..... | 18 |
| 3.1.3. Unoccupied Mode:..... | 18 |
| 3.1.3.1. (Idle State)..... | 18 |

| | |
|--|-----------|
| 3.1.3.2. (Heating State)..... | 18 |
| 3.1.3.3. (Push Button Override State)..... | 18 |
| 3.1.4. Morning Warmup Mode:..... | 18 |
| 3.1.5. Occupied Mode:..... | 18 |
| 3.1.6. Standby Occupancy Mode:..... | 18 |
| 3.1.7. Zone Damper:..... | 19 |
| 3.1.8. System Heating/Cooling Decision Process:..... | 19 |
| 3.1.8.1. Enable Criteria:..... | 19 |
| 3.1.8.2. Heating Enabled Mode..... | 19 |
| 3.1.8.3. Cooling Enabled Mode..... | 19 |
| 3.1.8.4. Default Ventilation Mode..... | 19 |
| 3.1.8.5. Forced Ventilation Mode..... | 19 |
| 3.1.9. Ventilation Lockout (Sequence):..... | 19 |
| 3.1.10. Heating Sequence:..... | 19 |
| 3.1.10.1. Outdoor Air Temperature used to determine Heating Enable Mode:..... | 19 |
| 3.1.10.2. Default Setpoint:..... | 19 |
| 3.1.10.3. Call for Heating:..... | 19 |
| 3.1.11. Cooling Sequence:..... | 20 |
| 3.1.11.1. Outdoor Air temperature used to determine cooling enable mode:..... | 20 |
| 3.1.11.2. Default Cooling Setpoint:..... | 20 |
| 3.1.11.3. Call for Cooling:..... | 20 |
| 3.1.12. Reference Zone Sequence:..... | 20 |
| 3.1.13. Forced Vent Sequence..... | 20 |
| 3.1.14. Slave Zones:..... | 20 |
| 3.1.15. System Heating Control:..... | 20 |
| 3.1.16. System Cooling Control:..... | 20 |
| 3.1.17. Bypass Operation:..... | 20 |
| 3.1.18. Ventilation Sequence:..... | 20 |
| 3.1.19. Economizer Operation (and CO2 Demand Control Ventilation) :..... | 21 |
| 3.1.20. Additional Rooms Partition Switch..... | 21 |
| 3.1.21. Limits and Safeties:..... | 21 |
| 3.1.22. Alarms:..... | 22 |
| 3.2. Single Zone HVAC Rooftop Sequence of Operations: (with Heating, Ventilating and Mechanical Cooling)..... | 22 |
| 3.2.1. Discretionary Fire Alarm Shutdown Mode:..... | 22 |
| 3.2.2. Freeze-stat Shutdown Mode(s):..... | 22 |
| 3.2.2.1. Software..... | 22 |
| 3.2.2.2. Hard-Wired..... | 22 |
| 3.2.3. Unoccupied Mode:..... | 22 |
| 3.2.3.1. (Idle State)..... | 22 |
| 3.2.3.2. (Heating State)..... | 22 |
| 3.2.3.3. (Push Button Override State)..... | 22 |
| 3.2.4. Morning Warmup Mode:..... | 23 |
| 3.2.5. Occupied Mode:..... | 23 |
| 3.2.6. Standby Occupancy Mode:..... | 23 |
| 3.2.7. Ventilation Lockout (Sequence):..... | 23 |
| 3.2.8. Heating Sequence:..... | 23 |
| 3.2.8.1. Outdoor Air Temperature used to determine Heating Enable Mode:..... | 23 |
| 3.2.8.2. Default Setpoint:..... | 23 |
| 3.2.8.3. Call for Heating:..... | 23 |
| 3.2.9. Cooling Sequence:..... | 24 |
| 3.2.9.1. Outdoor Air Temperature used to determine cooling enable mode:..... | 24 |
| 3.2.9.2. Default Setpoint:..... | 24 |
| 3.2.9.3. Call for Cooling:..... | 24 |

| | |
|--|-----------|
| 3.2.10. Ventilation Sequence: | 24 |
| 3.2.11. Economizer Operation (and CO2 Demand Control Ventilation) : | 24 |
| 3.2.11.8. Additional Rooms Partition Switch | 24 |
| 3.2.12. Limits and Safeties | 24 |
| 3.2.13. Alarms: | 25 |
| 3.3. Gym HV Rooftop Sequence of Operations: (with Heating and Ventilating Only) | 25 |
| 3.3.1. Discretionary Fire Alarm Shutdown Mode: | 25 |
| 3.3.2. Software Freezestat Shutdown Mode: | 25 |
| 3.3.3. Unoccupied Mode: | 25 |
| 3.3.3.1. (Idle State) | 25 |
| 3.3.3.2. (Heating State) | 25 |
| 3.3.3.3. (Push Button Override State) | 26 |
| 3.3.4. Morning Warmup Mode: | 26 |
| 3.3.5. Occupied Mode: | 26 |
| 3.3.6. Standby Occupancy Mode: | 26 |
| 3.3.7. Ventilation Lockout (Sequence): | 26 |
| 3.3.8. Heating Sequence | 26 |
| 3.3.8.1. Outdoor Air Temperature used to determine Heating Enabled Mode: | 26 |
| 3.3.8.2. Default Setpoint: | 26 |
| 3.3.8.3. Call for Heating: | 26 |
| 3.3.9. Economizer Operation (and CO2 Demand Control Ventilation): | 26 |
| 3.3.10. Gym Partition Switch | 27 |
| 3.3.11. Additional Rooms Partition Switch | 27 |
| 3.3.12. Limits and Safeties | 27 |
| 3.3.13. Alarms: | 27 |
| 3.4. HRV and ERV Unit Sequence of Operations: | 28 |
| 3.4.1. Discretionary Fire Alarm Shutdown Mode: | 28 |
| 3.4.2. Software Freezestat Shutdown Mode: | 28 |
| 3.4.3. Unoccupied Mode: | 28 |
| 3.4.4. Morning Warmup Mode: | 28 |
| 3.4.5. Occupied Mode: | 28 |
| 3.4.6. Econo Mode: | 28 |
| 3.4.10. Standby Occupancy Mode: | 28 |
| 3.4.11. Ventilation Lockout (Sequence): | 28 |
| 3.4.12. Limits and Safeties | 28 |
| 3.4.13. Alarms: | 28 |
| 3.5. Unit Ventilators Sequence of Operations: | 29 |
| 3.5.1. Discretionary Fire Alarm Shutdown Mode: | 29 |
| 3.5.2. Software Freezestat Shutdown Mode: | 29 |
| 3.5.3. Unoccupied Mode | 29 |
| 3.5.3.1. (Idle State) | 29 |
| 3.5.3.2. (Heating State) | 29 |
| 3.5.3.3. (Push Button Override State) | 29 |
| 3.5.4. Morning Warmup Mode: | 29 |
| 3.5.5. Occupied Mode | 29 |
| 3.5.6. Standby Occupancy Mode: | 29 |
| 3.5.7. Ventilation Lockout (Sequence): | 30 |
| 3.5.8. Heating: | 30 |
| 3.5.8.1. Outdoor Air Temperature used to determine Heating Enable Mode: | 30 |
| 3.5.8.2. Default Setpoint: | 30 |
| 3.5.8.3. Call for Heating: | 30 |
| 3.5.9. Cooling Sequence: | 30 |
| 3.5.9.1. Outdoor Air Temperature used to determine cooling enable mode: | 30 |

| | |
|---|-----------|
| 3.5.9.2. Default Setpoint:..... | 30 |
| 3.5.9.3. Call for Cooling:..... | 30 |
| 3.5.10. Economizer Operation (and CO2 Demand Control Ventilation) :..... | 30 |
| 3.5.11. Limits and Safeties..... | 31 |
| 3.5.12. Alarms..... | 31 |
| 3.6. Air Handlers Sequence of Operations:..... | 31 |
| 3.6.1. Discretionary Fire Alarm Shutdown Mode:..... | 31 |
| 3.6.2. Freeze-stat Shutdown Mode(s):..... | 31 |
| 3.6.2.1. Software..... | 31 |
| 3.6.2.2. Hard-Wired..... | 32 |
| 3.6.3. Unoccupied Mode:..... | 32 |
| 3.6.3.1. (Idle State)..... | 32 |
| 3.6.3.2. (Heating State)..... | 32 |
| 3.6.3.3. Push Button Override State)..... | 32 |
| 3.6.4. Morning Warmup Mode:..... | 32 |
| 3.6.5. Occupied Mode:..... | 32 |
| 3.6.6. Standby Occupancy Mode:..... | 32 |
| 3.6.7. Ventilation Lockout (Sequence):..... | 32 |
| 3.6.8. Heating Sequence:..... | 33 |
| 3.6.8.1. Outdoor Air Temperature used to determine Heating Enabled Mode:..... | 33 |
| 3.6.8.2. Default Setpoint:..... | 33 |
| 3.6.8.3. Call for Heating:..... | 33 |
| 3.6.9. Mechanical Cooling Sequence:..... | 33 |
| 3.6.9.1. Default Setpoint:..... | 33 |
| 3.6.9.2. Call for Cooling:..... | 33 |
| 3.6.9.3. Chilled Water Cooling..... | 33 |
| 3.6.10. Free Cooling Sequence:..... | 33 |
| 3.6.10.1. Outdoor Air Temperature used to determine cooling enable mode:..... | 33 |
| 3.6.10.2. Default Setpoint:..... | 33 |
| 3.6.10.3. Call for Cooling:..... | 33 |
| 3.6.11. Economizer Operation (and CO2 Demand Control Ventilation):..... | 33 |
| 3.6.11.1. Minimum Outdoor Air Damper Position..... | 33 |
| 3.6.11.2. Economizer Operation..... | 33 |
| 3.6.12. Additional Rooms Partition Switch..... | 34 |
| 3.6.13. Limits and Safeties..... | 34 |
| 3.6.14. Alarms:..... | 34 |
| 3.7. VAV AHU HVAC Fan System Sequence of Operations:..... | 35 |
| 3.7.1. Discretionary Fire Alarm Shutdown Mode:..... | 35 |
| 3.7.2. Freezestat Shutdown Modes:..... | 35 |
| 3.7.2.1. Software..... | 35 |
| 3.7.2.2. Hard-Wired..... | 35 |
| 3.7.3. Unoccupied Mode:..... | 35 |
| 3.7.3.1. (Idle State)..... | 35 |
| 3.7.3.2. (Heating State)..... | 35 |
| 3.7.3.3. (Push Button Override State)..... | 35 |
| 3.7.4. Morning Warmup Mode:..... | 35 |
| 3.7.5. Occupied Mode:..... | 36 |
| 3.7.6. Standby Occupancy Mode:..... | 36 |
| 3.7.7. Ventilation Lockout (Sequence):..... | 36 |
| 3.7.8. Supply Air Temperature Setpoint:..... | 36 |
| 3.7.9. Supply Air Static Pressure Setpoint:..... | 36 |
| 3.7.10. Heating Sequence:..... | 36 |
| 3.7.10.1. Default Setpoint:..... | 36 |

| | |
|--|-----------|
| 3.7.10.2. Call for Heating: | 36 |
| 3.7.11. Mechanical Cooling Sequence: | 37 |
| 3.7.11.1. Default Setpoint: | 37 |
| 3.7.11.2. Call for Cooling: | 37 |
| 3.7.12. Economizer Operation (Free Cooling) and Carbon Dioxide Demand Control Ventilation: | 37 |
| 3.7.13.6. Additional Rooms Partition Switch: | 37 |
| 3.7.14. Limits and Safeties: | 37 |
| 3.7.15. Alarms: | 38 |
| 3.7.16. VAV Box Sequence of Operations: | 38 |
| 3.7.16.1. Fan Powered VAV Box (with reheat coil / radiant panel): | 39 |
| 3.7.16.2. Damper-Only (no reheat or fan-powered box): | 39 |
| 3.7.16.3. Damper-Only (with reheat coil / radiation valve): | 39 |
| 3.7.16.4. Fan Powered VAV Bypass / Dump Box (with reheat coil / radiant panel): | 39 |
| 3.8. Multizone HVAC Sequence of Operations: | 39 |
| 3.8.1. Discretionary Fire Alarm Shutdown Mode: | 39 |
| 3.8.2. Freeze-stat Shutdown Mode(s): | 39 |
| 3.8.2.1. Software: | 39 |
| 3.8.2.2. Hard-Wired: | 39 |
| 3.8.3. Unoccupied Mode: | 39 |
| 3.8.3.1. (Idle State): | 40 |
| 3.8.3.2. (Heating State): | 40 |
| 3.8.3.3. (Push Button Override State): | 40 |
| 3.8.4. Morning Warmup Mode: | 40 |
| 3.8.5. Occupied Mode: | 40 |
| 3.8.6. Standby Occupancy Mode: | 40 |
| 3.8.7. Zone Damper Control: | 41 |
| 3.8.9. Ventilation Lockout (Sequence): | 41 |
| 3.8.10. Heating Sequence: | 41 |
| 3.8.10.1. Outdoor Air Temperature used to determine Heating Enable Mode: | 41 |
| 3.8.10.2. Default Setpoint: | 41 |
| 3.8.10.3. Call for Heating: | 41 |
| 3.8.10.4. Hot Deck: | 41 |
| 3.8.11. Cooling Sequence: | 41 |
| 3.8.11.1. Outdoor air temperature used to determine cooling enable mode: | 41 |
| 3.8.11.2. Default Setpoint: | 41 |
| 3.8.11.3. Call for Cooling: | 41 |
| 3.8.11.4. Cold Deck: | 41 |
| Zone Damper Control: | 42 |
| 3.8.12. Ventilation Sequence: | 42 |
| 3.8.13. Economizer Operation (and CO2 Demand Control Ventilation) : | 42 |
| 3.8.14. Additional Rooms Partition Switch: | 42 |
| 3.8.15. Limits and Safeties: | 42 |
| 3.8.16. Alarms: | 43 |
| 3.9. Heat Pump Gas Fired Multi Zone Sequence of Operations: | 43 |
| 3.9.2. Discretionary Fire Alarm Shutdown Mode: | 43 |
| 3.9.3. Freeze-stat Shutdown Mode(s): | 43 |
| 3.9.3.1. Software: | 43 |
| 3.9.3.2. Hard-Wired: | 43 |
| 3.9.4. Unoccupied Mode: | 43 |
| 3.9.4.1. (Idle State): | 44 |
| 3.9.4.2. (Heating State): | 44 |
| 3.9.4.3. (Push Button Override State): | 44 |
| 3.9.5. Morning Warmup Mode: | 44 |

| | |
|--|-----------|
| 3.9.6. Occupied Mode:..... | 44 |
| 3.9.7. Standby Occupancy Mode:..... | 44 |
| 3.9.8. Zone Damper Control..... | 45 |
| 3.9.9. Ventilation Lockout (Sequence):..... | 45 |
| 3.9.10. Heating Sequence:..... | 45 |
| 3.9.10.1. Outdoor Air Temperature used to determine Heating Enable Mode:..... | 45 |
| 3.9.10.2. Default Setpoint:..... | 45 |
| 3.9.10.3. Call for Heating:..... | 45 |
| 3.9.10.4. Dedicated Furnace..... | 45 |
| 3.9.11. Cooling Sequence:..... | 45 |
| 3.9.11.1. Outdoor air temperature used to determine cooling enable mode:..... | 45 |
| 3.9.11.2. Default Setpoint:..... | 45 |
| 3.9.11.3. Call for Cooling:..... | 45 |
| 3.9.11.4. Dedicated Furnace..... | 45 |
| Zone Damper Control:..... | 45 |
| 3.9.12. Ventilation Sequence:..... | 45 |
| The outdoor air flow rate is calculated according to each fan speed and outdoor air damper position and this cycles on the exhaust fans to balance the air flow..... | 45 |
| 3.9.13. Economizer Operation (and CO2 Demand Control Ventilation) :..... | 45 |
| 3.9.14. Additional Rooms Partition Switch..... | 46 |
| 3.9.16. Alarms:..... | 46 |
| 3.10. Hydronic Boiler Sequence of Operations:..... | 47 |
| 3.10.1. System Enable/Disable Criteria for Winter Mode:..... | 47 |
| 3.10.2. System Enable/Disable Criteria for Summer Mode:..... | 47 |
| 3.10.3. Changeover from Summer to Winter Mode:..... | 47 |
| 3.10.4. Hot Water Supply Temperature Setpoint Determination..... | 47 |
| 3.10.5. Morning Warm-Up Mode:..... | 47 |
| 3.10.6. Unoccupied Mode:..... | 47 |
| 3.10.7. Minimum Zone Temperature Deviation Reset:..... | 47 |
| 3.10.8. Summary:..... | 47 |
| 3.10.9. Lead/Lag operation:..... | 48 |
| 3.10.11. Main Pump Modulated Flow:..... | 49 |
| 3.10.12. Limits and Safeties:..... | 49 |
| 3.10.13. Alarms:..... | 49 |
| 3.11. Hydronic Heating Control Valves Sequence of Operations: (ready for review)..... | 49 |
| 3.11.1. Hot Water Rads:/Radiant Panels..... | 49 |
| 3.12. Limits and Safeties..... | 49 |
| 3.13. Alarms..... | 49 |
| 3.14. Chilled Water Control Valves Sequence of Operations: (ready for review)..... | 49 |
| 3.15. In Floor Hydronic Heating Sequence of Operations: (ready for review)..... | 49 |
| 3.16. Cooling Tower with Heat Pump Loop - Sequence of Operations: (ready for review)..... | 49 |
| 3.16.1. Cooling Tower Disabled Mode..... | 49 |
| 3.16.2. Cooling Tower Enabled Mode..... | 50 |
| 3.16.8. Limits and Safeties..... | 50 |
| 3.16.9. Alarms..... | 50 |
| 3.17. Chilled Water Cooling System Sequence of Operations: (ready for review)..... | 50 |
| 3.17.1. Chiller Disabled Mode..... | 50 |
| 3.17.2. Chiller Enabled Mode:..... | 50 |
| 3.17.3. Limits and Safeties:..... | 50 |
| 3.17.4. Alarms:..... | 51 |
| 3.18. Cooling Coils Sequence of Operations: (ready for review)..... | 51 |
| 3.18.1. Unoccupied Mode..... | 51 |
| 3.18.2. Occupied Mode..... | 51 |

| | |
|--|-----------|
| 3.18.3. Limits and Safeties: | 51 |
| 3.18.4. Alarms: | 51 |
| 3.19. Ductless Split - Cooling Only Unit Sequence of Operations: (ready for review) | 51 |
| 3.19.1. Unoccupied Mode: | 51 |
| 3.19.2. Occupied Mode: | 51 |
| 3.19.3. Limits and Safeties: | 51 |
| 3.19.4. Alarms: | 51 |
| 3.20. Ductless Split - Heat Pump Sequence of Operations: (ready for review) | 51 |
| 3.20.1. Unoccupied Mode: | 51 |
| 3.20.2. Occupied Mode: | 51 |
| 3.20.3. Limits and Safeties: | 51 |
| 3.20.4. Alarms: | 52 |
| 3.21.1. Discretionary Fire Alarm Shutdown Mode: | 52 |
| 3.21.2. Software Freeze-stat Shutdown Mode: | 52 |
| 3.21.3. Unoccupied Mode: | 52 |
| 3.21.3.1. (Idle State): | 52 |
| 3.21.3.2. (Heating State): | 52 |
| 3.21.3.3. (Push Button Override State): | 52 |
| 3.21.4. Morning Warmup Mode: | 52 |
| 3.21.5. Occupied Mode: | 52 |
| 3.21.6. Standby Occupancy Mode: | 52 |
| 3.21.7. Heating Sequence: | 53 |
| 3.21.7.1. Outdoor Air Temperature used to determine Heating Enable Mode: | 53 |
| 3.21.7.2. Default Setpoint: | 53 |
| 3.21.7.3. Call for Heating: | 53 |
| 3.21.8. Cooling Sequence: | 53 |
| 3.21.8.1. Outdoor Air temperature used to determine cooling enable mode: | 53 |
| 3.21.8.2. Default Cooling Setpoint: | 53 |
| 3.21.8.3. Call for Cooling: | 53 |
| 3.21.9. Limits and Safeties: | 53 |
| 3.21.10. Alarms: | 53 |
| 3.22. Electric Heat Sequence of Operation (ready for review) | 53 |
| 3.22.1. Stairwells and Vestibules: | 53 |
| 3.22.1.1. Heating Disabled: | 53 |
| 3.22.1.2. Heating Enabled: | 53 |
| 3.22.1.3. Limits and Safeties: | 53 |
| 3.22.1.4. Alarms: | 53 |
| 3.22.2. Utility Spaces: | 54 |
| 3.23. Fan Coil Units (ready for review) | 54 |
| 3.23.1. Unoccupied Mode: | 54 |
| 3.23.2. Occupied Mode: | 54 |
| 3.23.3. Limits & Safeties: | 54 |
| 3.23.7. Alarms: | 54 |
| 3.24. Force Flow Heater Sequence of Operations: (to be updated ready for review) | 54 |
| 3.24.1. Unoccupied Mode: | 54 |
| 3.24.2. (Idle State): | 54 |
| 3.24.2.1. (Heating State): | 54 |
| 3.24.2.3. (Push Button Override State): | 54 |
| 3.24.3. Occupied Mode: | 54 |
| 3.24.4. Heating Sequence: | 54 |
| 3.24.4.1. Outdoor Air Temperature used to determine Heating Enable Mode: | 54 |
| 3.24.4.2. Default Setpoint: | 54 |

| | |
|--|-----------|
| 3.24.4.3. Call for Heating: | 54 |
| 3.24.6. Limits & Safeties | 54 |
| 3.24.8. Alarms | 54 |
| 3.25. Exhaust Fan Sequence of Operations: (to be updated then ready for review) | 55 |
| 3.25.2. Unoccupied Mode: | 55 |
| 3.25.2.1. (Idle State) | 55 |
| 3.25.3. Occupied Mode: | 55 |
| 3.25.4. Limits and Safeties: | 55 |
| 3.25.5. Alarms: | 55 |
| 3.26. Fume Hood Sequence of Operations: (to be reviewed) | 55 |
| 3.26.1. Occupied Mode: | 55 |
| 3.26.2. Unoccupied Mode: | 55 |
| 3.26.3. Limits and Safeties: | 55 |
| 3.26.4. Alarms: | 55 |
| 3.27. Kitchen Exhaust Hood Fan Sequence of Operations: (to be reviewed) | 55 |
| 3.27.1. Occupied Mode: | 55 |
| 3.27.2. Unoccupied Mode: | 55 |
| 3.27.3. Limits and Safeties: | 55 |
| 3.27.4. Alarms: | 56 |
| 3.28. Make Up Air Unit Sequence of Operations: (ready for review) | 56 |
| 3.28.1. Discretionary Fire Alarm Shutdown Mode: | 56 |
| 3.28.2. Software Freeze-stat Shutdown Mode: | 56 |
| 3.28.3. Unoccupied Mode: | 56 |
| 3.28.3.1. (Idle State) | 56 |
| 3.28.3.2. (Heating State) | 56 |
| 3.28.3.3. (Push Button Override State) | 56 |
| 3.28.4. Morning Warmup Mode: | 56 |
| 3.28.5. Occupied Mode: | 56 |
| 3.28.6. Standby Occupancy Mode: | 56 |
| 3.28.7. Ventilation Lockout (Sequence): | 57 |
| 3.28.8. Supply Air Temperature Setpoint: | 57 |
| 3.28.9. Heating Sequence: | 57 |
| 3.28.9.1. Outdoor Air Temperature used to determine Heating Enable Mode: | 57 |
| 3.28.9.2. Default Setpoint: | 57 |
| 3.28.9.3. Call for Heating: | 57 |
| 3.28.10. Cooling Sequence: | 57 |
| 3.28.10.1. Outdoor Air temperature used to determine cooling enable mode: | 57 |
| 3.28.10.2. Default Cooling Setpoint: | 57 |
| 3.28.10.3. Call for Cooling: | 57 |
| 3.28.11. Limits and Safeties: | 57 |
| 3.28.12. Alarms: | 58 |
| 3.29. Furnace Sequence of Operation: (ready to review) | 58 |
| 3.29.1. Discretionary Fire Alarm Shutdown Mode: | 58 |
| 3.29.2. Unoccupied Mode: | 58 |
| 3.29.2.1. (Idle State) | 58 |
| 3.29.2.2. (Heating State) | 58 |
| 3.29.3. (Push Button Override State) | 58 |
| 3.29.4. Occupied Mode: | 58 |
| 3.29.5. Standby Occupancy Mode: | 58 |
| 3.29.6. Heating Sequence: | 58 |
| 3.29.6.1. Outdoor Air Temperature used to determine Heating Enable Mode: | 58 |
| 3.29.6.2. Default Setpoint: | 59 |

| | |
|---|-----------|
| 3.29.6.3. Call for Heating:..... | 59 |
| 3.29.7. Limits and Safeties:..... | 59 |
| 3.29.8. Alarms:..... | 59 |
| 3.30. Destratification Fans Sequence of Operation: (Library/Gyms/Atrium)..... | 59 |
| 3.31. Exterior Lighting Sequence of Operation:..... | 59 |
| 3.31.1. Exterior Building Lights..... | 59 |
| 3.31.2. Parking Lot Lights..... | 59 |
| 3.31.3. Exterior School Sign..... | 59 |
| 3.32. Domestic Hot Water Recirc Pump (only enable/disable based on time of day schedule for secondary schools - elementary to use stand alone time/aquastat provided by others)..... | 59 |
| 3.33. Low Temperature Alarm Sequence of Operation (ready for review)..... | 59 |
| 3.34. Space Temperature..... | 59 |
| 3.36. Free Cooling Setpoint Sequence of Operation..... | 60 |
| 3.37. Miscellaneous Monitoring (ready for review)..... | 60 |
| 3.37.1. Sump Pump Level Alarm (not by BAS)..... | 60 |
| 3.37.2. VFD Drive Fault..... | 60 |
| 3.37.3. Boiler Fault..... | 60 |
| 3.37.4. Chiller Fault..... | 60 |
| 3.37.5. Rooftop Unit Fault..... | 60 |
| 3.38. Energy Conservation Measures..... | 60 |
| 3.38.1. Demand Limiting Control..... | 60 |
| 3.38.2. Orderly Shutdown..... | 60 |
| 3.38.3. Weekly fan runtime monitoring..... | 60 |
| 3.38.4. Trend generation..... | 60 |
| 3.38.5. Trend Archival operations..... | 61 |
| 3.38.6. Trend Data Analysis Support..... | 61 |
| 3.38.7. Reporting Requirements..... | 61 |
| 3.39. Setpoints and Schedule Standards (ready for review)..... | 61 |
| 3.39.1. Default Occupied Room Heating Setpoint..... | 61 |
| 3.39.2. Default Occupied Room Cooling Setpoint..... | 61 |
| 3.39.3. Default Standby Room Heating Setpoint..... | 61 |
| 3.39.4. Default Standby Room Cooling Setpoint..... | 61 |
| 3.39.5. Default Unoccupied Room Heating Setpoint..... | 61 |
| 3.39.6. Default Unoccupied Room Cooling Setpoint..... | 61 |
| 3.39.7. Default Gym Occupied Room Heating Setpoint..... | 61 |
| 3.39.8. Default Occupied Schedule..... | 61 |
| 3.39.9. Default Standby Schedule..... | 61 |
| 3.39.10. Holiday Calendar Schedule..... | 61 |
| 3.40. Alarm Handling..... | 61 |
| 3.41. Outside Air Temperature..... | 61 |
| 3.42. Outside Air Humidity..... | 61 |
| 3.43. Carbon Dioxide..... | 61 |
| 3.44. Static Pressure..... | 62 |
| 3.45. Graphics..... | 62 |
| 3.45.1. Navigation..... | 62 |
| 3.45.2. Structure..... | 62 |
| 3.45.3. Symbols..... | 62 |
| 3.45.4. Colours..... | 62 |
| 3.45.5. Legend..... | 62 |
| 3.45.6. Floor Plan..... | 62 |
| 3.45.7. Systems..... | 62 |
| 3.45.8. Setpoint..... | 62 |

| | |
|---|-----------|
| 3.45.9. Levels of Access..... | 62 |
| 3.46. Security..... | 62 |
| 3.46.1. Levels of Access..... | 62 |
| 4. Appendix:..... | 62 |
| 4.1. Appendix A: Humidity-Limited Free Cooling Table..... | 62 |
| 4.2. Appendix B: Outside Air Temperature Limited Free Cooling Table..... | 64 |
| 5. Reference Section:..... | 65 |
| 5.1. Cooling Tower from Jacob Hespler..... | 65 |
| 5.2. Gym Unit from Groh..... | 65 |
| 5.3. Gym Units from Millen Woods..... | 66 |
| 5.4. Gym Units from Edna Staebler..... | 66 |
| 5.5. Unit Ventilators (referenced from Crestview, Laurentian, Doon, Conestogo)..... | 67 |
| 5.6. Heat Pumps (referenced from Brigadoon, Jacob Hespler)..... | 69 |

1. Integration Requirements

General Sequence of Global and Local Operation

1.1. Holiday Schedule

A calendar based schedule that is user adjustable at a global (board wide) or local (site specific) level. Typical entries include the standard board and statutory holidays that apply to the school board: New Year's Day, Christmas Day, Boxing Day, Christmas Holidays, Canada Day, etc. and are pre-defined at the front end Server Dashboard.

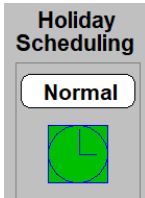

1.2. Global Ventilation Schedule

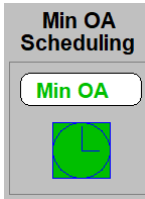

A time of day schedule that is user adjustable at global (board wide) or local (site specific) level. Typical entries include: 7:00 a.m. to 4:00 p.m. Monday to Friday.

Outside of this schedule all outdoor air dampers are maintained (spring return / fail) closed when Global Ventilation is disabled.



1.3. Cooling Enabled Mode

A set of thresholds that are user adjustable at a global (board wide) or local (site specific) level, triggers the cooling enable mode based on the outdoor air temperature exceeding the threshold. The threshold is further adjusted by a calendar schedule. Typical default values are: 18 °C from May to September, except 21 °C from June to August.

| <u>Mechanical Systems</u> | | |
|--------------------------------|---|---|
| <u>Outside Air Temperature</u> | | |
| <u>Enable Setpoints</u> | | |
| | <u>Heating</u> | <u>Cooling</u> |
| Status | Winter | Winter |
| Schedule |  |  |
| Winter | 14.0 °C | 26.0 °C |
| Summer | 12.0 °C | 17.0 °C |
| Actual | 14.0 °C | 26.0 °C |

1.4. Heating Enabled Mode

A set of thresholds that are user adjustable at a global (board wide) or local (site specific) level, triggers the heating enable mode based on the outdoor air temperature below the threshold. The threshold is further adjusted by a calendar schedule. Typical default values are: 16°C from September to May, except 5°C from June to August.

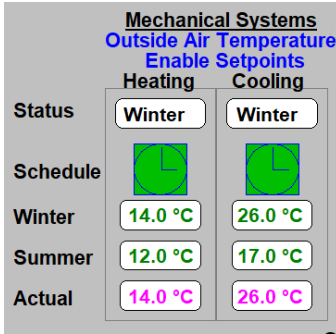

1.5. Free Cooling Setpoint Calculation

The average outdoor air relative humidity is sent from the Niagara Server to the Global Input for all schools / Ed Centre where the Free Cooling Setpoint is calculated. Free cool is enabled when OAT < minimum (23.5°C, 29.4°C - $\Phi/7.43$) where Φ is the average relative humidity in %RH.

The free cooling signal is 100% when the OAT is more than 2°C below the free cooling setpoint. The free cooling signal decreases towards zero linearly as the outdoor air temperature increases from 2 °C below the free cooling setpoint to 0 % at the setpoint. This free cooling signal is used in each mixed air damper controller as the maximum the outdoor air dampers can open. Minimum outdoor air damper position signal may exceed the free cooling signal. The free cooling signal is still subject to the mixed damper safeties that would keep minimum position during occupied mode. Also the free cooling signal will be at a lower priority than the CO₂ demand ventilation (where applicable) up to 40% outside damper position.

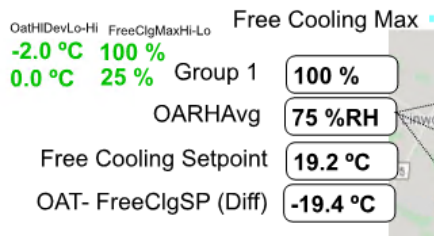

1.6. Sample Calculations Tables:

1.6.1. Humidity-Limited Free Cooling

The table in Appendix 'A' serve to illustrate the net result of the Free Cooling Setpoint Calculation formula for a given dataset of Outdoor Air Humidity (average relative humidity in %RH) and Outdoor Air Temperatures (OAT in °C)

1.6.2. Outside Air Temperature Limit Free Cooling

This table in Appendix 'B' serve to illustrate the net result of the Outdoor Low Limit Calculation formula for a given dataset of Outdoor Air Temperatures (OAT in °C)

The Outdoor Low Limit Calculation is used to restrict the maximum outdoor damper position when the outdoor air temperature is too cold for the proper operation of the mechanical equipment as an additional preventative level of freeze protection.

1.7. Minimum Outdoor Air Enable Time Schedule:

A set of time schedules, one for each of the 4 school board areas are configured (typically from 7:00 a.m. to 4:00 p.m., to send an enable flag to each site to allow outside air mixing dampers to open to minimum position, economizer operation (for required cooling demand) or return air CO₂ (for required ventilation demand).

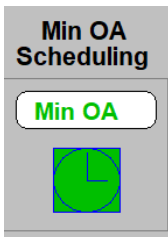

1.8. Minimum Outdoor Air Mixing Damper Position Setpoint:

A set of Minimum Outdoor Air Position, one for each of the the 4 school board areas are configured (typically 10 %) PGL should this not be 5% or min permitted by ASHRAE 6.2 Table 6-2 Area Outdoor Air Rate - Educational Facilities at 0.06, 0.12 and 0.18 cfm/ft2 - no corridor, no utility space, etc ? added by LLI June 6, to send to each of the sites to send the outdoor air mixing dampers to open to minimum position when the Minimum Outdoor Air Enable Time Schedule is enabled and there are no additional demands for cooling or ventilation are called.

Area 1 MinOASP 100 %

1.9. Night Setback Heating Setpoint:

Reset from outdoor air temperature. The setpoint is used as a threshold to determine if the system is to be automatically brought out of an idle night setback mode and into an active heating mode.

| Outside Air | NSB SP |
|-------------|---------|
| 0.0 °C | 16.0 °C |
| -20.0 °C | 18.0 °C |

1.10. BAS Designations:

System Point Nomenclature

Each of the system components are to be named or referenced in the BAS system as per the following table. Consultants/ designers / contractors are to use the same reference designation in schedules / specifications and equipment labels to ensure conformity with control operations, future warranty and maintenance and associated work order systems.

| COMPONENT DESCRIPTION | BAS DESIGNATION |
|---|-----------------|
| Air Handling Unit | AHU |
| Boiler | B |
| Bypass Damper | BD |
| Bypass Box (Dump Box) | BB |
| Cabinet Heater | CH |
| Chiller | CHR |
| Condensing Units / Heat Pump Unit | CU |
| Cooling Tower | CT |
| Domestic Hot Water Heater | DHW |
| Ductless Split | DS |
| Electric Heater | EH |
| Energy Recovery Ventilator | ERV |
| Exhaust Fan | EF |
| Fan Coil | FC |
| Gas Fired Heat Pump | GHP |
| Heat Pumps | HP |
| Variable Refrigerant Flow Unit | VRF |
| Heat Recovery Ventilator | HRV |
| Heating & Ventilation Unit | HV |
| Heating Ventilation & Air Conditioning Unit | HVAC |
| Make Up Air Unit | MUA |
| Multizone Unit | MZ |

| | |
|--|------------------|
| Outside Lighting | Outside Lighting |
| Package Cooling Only Unit | AC |
| Packaged Terminal Air Conditioner | PTAC |
| Pump or Circulator (Domestic, Storm/Sanitary, Chilled, Heating Water) | P |
| Radiator | RAD |
| Radiant Floor Heat | RFH |
| Radiant Panel | RP |
| Reheat Coil | RHC |
| Return Fan | RF |
| Supply Fan | SF |
| Unit Heater | UH |
| Unit Ventilator | UV |
| Variable Air Volume Damper | VAV |
| Variable Volume Temperature Damper | VVT |
| Water Main Auto Flush | WM Auto Flush |

2. Definitions:

2.1. Global Functions:

A set of setpoints and schedules managed by the high level operator from a central server dashboard.

Global Setpoint System

LEGEND
 0.0 °C Adjustable Setpoint
 0.0 °C Calculated Value
 0.0 °C Measurement

Outside Air -0.5 °C

Mechanical Systems
 Outside Air Temperature Enable Setpoints

| | | | | | | |
|----------|---------|---------|----------|---------|---------|---------|
| Status | Winter | Winter | Status | Comfort | Economy | Comfort |
| Schedule | | | Schedule | | | |
| Winter | 14.0 °C | 26.0 °C | Comfort | 21.0 °C | 28.0 °C | 0.0 °C |
| Summer | 12.0 °C | 17.0 °C | Economy | 16.0 °C | 40.0 °C | 1.0 °C |
| Actual | 14.0 °C | 26.0 °C | Actual | 21.0 °C | 40.0 °C | 0.0 °C |

Zone Temperature Control
 Night Setback Zone Temperature Setpoint Heating Cooling Setpoint Adjust

| | | | |
|----------|---------|---------|---------|
| Status | Comfort | Economy | Comfort |
| Schedule | | | |
| Comfort | 21.0 °C | 28.0 °C | 0.0 °C |
| Economy | 16.0 °C | 40.0 °C | 1.0 °C |
| Actual | 21.0 °C | 40.0 °C | 0.0 °C |

Outside Air NSB SP
 0.0 °C 16.0 °C
 -20.0 °C 18.0 °C

Holiday Scheduling Normal **Min OA Scheduling** Min OA

Humidity Maximum Damper Position
 Outdoor Air Humidity 83 %RH
 Free Cooling Setpoint 18.3 °C
 Free Cooling Maximum 0 %

[Humidity Detail](#)

[Humidity Map](#)

[Min OA Detail](#)

[Heating Detail](#)

[Astroclock Detail](#)

* For all setpoints, schedule determines the setpoint selection.
 Heating enable = OAT < OatEnableSP
 Cooling enable = OAT > OatEnableSP
 To schedule setpoints, select weekly schedule ON for ALL DAY and ALL WEEK, and use the Alternate schedule dates in the OFF ALL DAY position to activate "Summer" or "Economy" setpoint selection.

2.2. Local Functions:

A set of setpoints and schedules managed by the high level operator from a site specific dashboard.graphic.

| Local/Global Mode | | | | | | | | | |
|-------------------|--------------------|---------|--------------------|---------|----------------------|----------------------|----------------------|------------------|----------------|
| | OAT Heating Enable | | OAT Cooling Enable | | Zone Setback Heating | Zone Setback Cooling | Zone Setpoint Adjust | Holiday Schedule | MinOA Schedule |
| Status | Enabled | | Disabled | | | | | | |
| Local | 12.0 °C | 17.0 °C | 21.0 °C | 35.0 °C | 0.0 °C | Normal | Enabled | | |
| Global | 14.0 °C | 26.0 °C | 21.0 °C | 40.0 °C | 0.0 °C | Normal | Enabled | | |
| Actual | 14.0 °C | 26.0 °C | 21.0 °C | 40.0 °C | 0.0 °C | Normal | Enabled | | |

2.3. Local Mode of Operation:

When the local/global flag is set to Local mode, the global setpoints and schedules are ignored and the local setpoints and schedules are used to determine the various enable/disable modes of operation.



2.4. Global Mode of Operation:

When the local/global flag is set to Global mode, the local setpoints and schedules are ignored and the global setpoints and schedules are used to determine the various enable/disable modes of operation.



2.5. Server Based Holiday Scheduling

A central master holiday calendar-based schedule overrides the regular time schedule of each system unless exempted on a system-by-system basis.

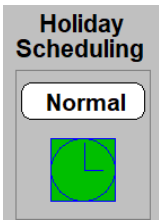

2.6. Server based Humidity:

Each school is placed into one of three humidity zones when the nearest three outdoor humidity sensors are averaged at the server level and then distributed to each of the three humidity zones.

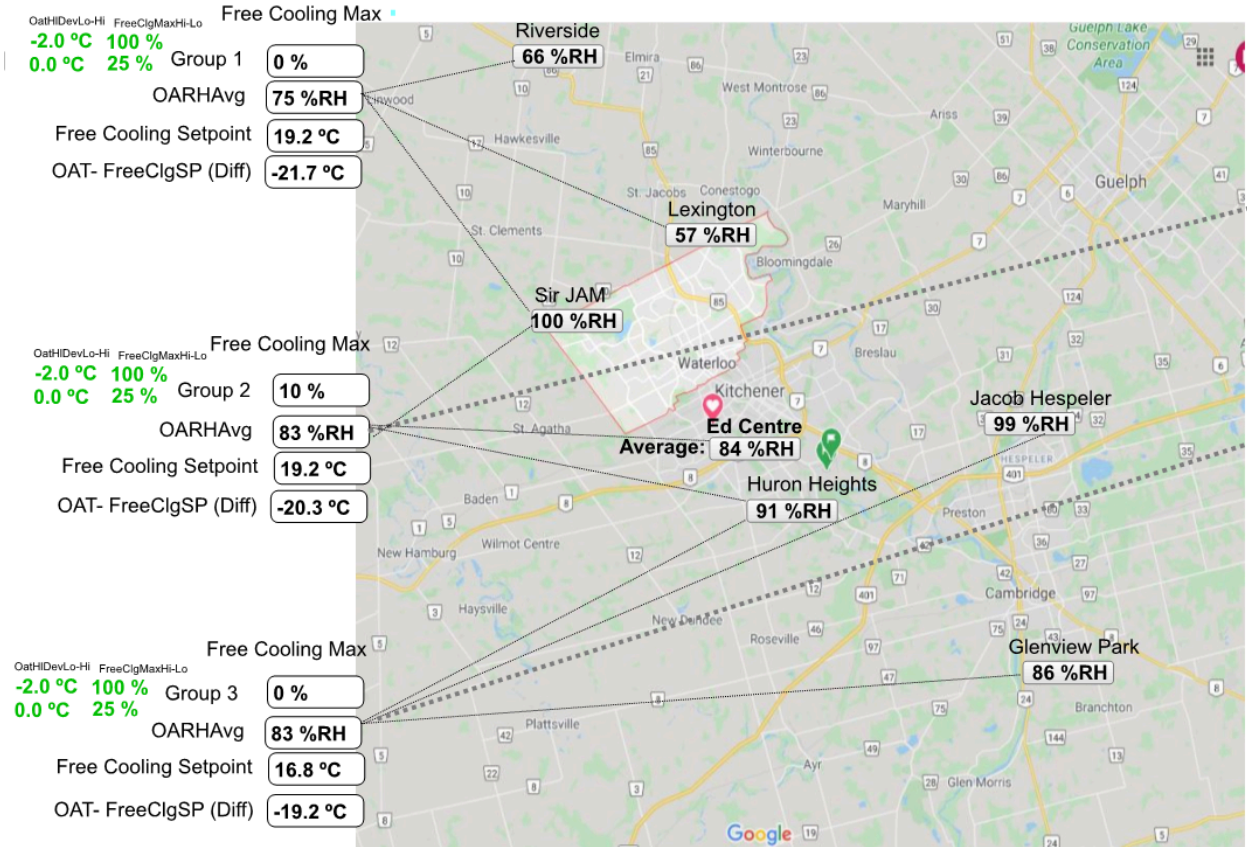

2.7. Server based Heating Reset Setpoints:

Each school with hot water systems will have a set of outdoor heating reset parameters sent to it based on one of four area locations. These reset parameters are managed by a high level operator from a central server dashboard.



2.8. Server based Astroclock:

Each school with outdoor lighting will have a set of lighting offset parameters sent to it based on one of four area locations. These parameters will provide an offset (in minutes, typically -15 minutes) to direct the lights off after sunrise and the lights on before sunset.

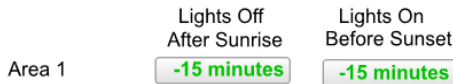

2.9. Fire Alarm Sequence of Operation:

On a fire alarm condition, an alarm is generated at the BAS and all supply fans stop (except exhaust fans stay under automatic control) in order to alleviate smoke movement. This is not intended as a safety interlock - only to avoid unnecessary alarms at the BAS. Unless otherwise directed by the local authority having jurisdiction.

2.10. Server based Minimum Outdoor Air Damper Position Setpoint:

Each school will have a minimum outdoor damper position setpoint sent to it based on one of four area locations. These parameters are managed by a high level operator from a central server dashboard.

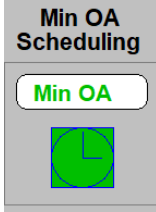

2.11. Server based Mechanical Systems Outdoor Air Temperature Enable Setpoints:

Each school will have a threshold for enabling mechanical heating or cooling based on outdoor air temperature thresholds. These parameters are managed by a high level operator from a central server dashboard.

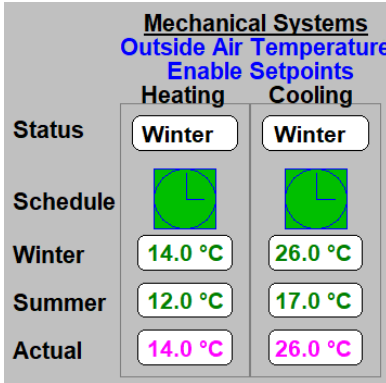

2.12. Server based Zone Temperature Control for Night Setback Heating Setpoints and Setpoint Adjusts:

Each school will have a threshold for enabling the night setback mode when the calculated lowest zone for a particular system falls below threshold. Also the default setpoint can be adjusted to allow for a higher setpoint for the cooling season and holidays. These parameters are managed by a high level operator from a central server dashboard

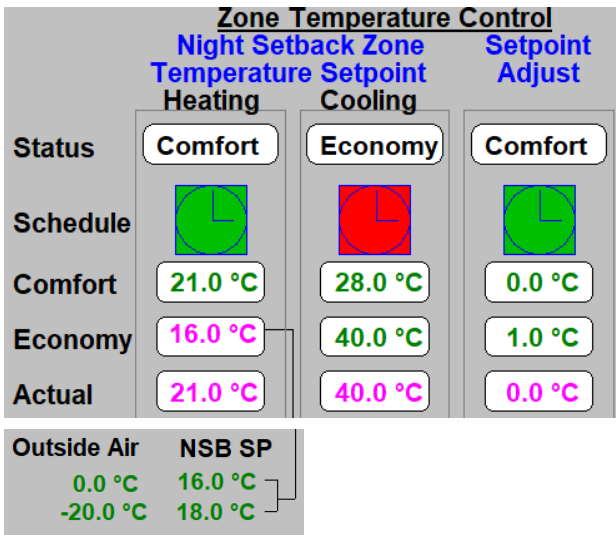

2.13. Local System-Based Default Room (Heating) Setpoint

Each air handler and rooftop HVAC system will have an independently adjustable setpoint (in °C) from the system graphic for the user with custodial-level security privileges.

2.14. Local System-Based Time Schedule

Each exhaust fan, outdoor lighting, air handler and rooftop HVAC system will have an independently adjustable time schedule (with hours of the day repeating weekly) from the system graphic for the user with at least custodial-level security privileges and above.

2.15. Outdoor Air Temperature

Each site will have its own dedicated outdoor air temperature sensor wired to an input of a controller. The controller will share the outdoor air temperature with all the other controllers on site for use in various functions which include determining temperature setpoints and enable/disable thresholds for equipment operation.

2.16. Optimized Start Program

Each HVAC system with a time of day schedule will utilize the controller's internal Optimized Start Program to determine the actual start time for the Morning Warm-Up Mode of operation. The controller's Optimized Start Program parameters and inputs are to be configured as follows:

Inputs:

- 1) Outdoor Air Temperature
- 2) Room Temperature or Lowest Zone Temperature (where applicable)
- 3) Local System-Based Time Schedule
- 4) Local System-Based Default Room Heating Setpoint
- 5) Local System-Based Unoccupied Room Heating Setpoint (Distech)

Parameters:

- 1) Maximum Start time offset 105 minutes
- 2) Maximum Temperature offset 2 °C

The Optimized Start Program functions with an algorithm that keeps an internal history of the inputs and its calculated start times that is self-adjusting based on the past performance of the system's Morning Warm up Mode.

2.17. Morning Warmup Mode:

An optimized start, based on the time of day schedule, outdoor air temperature and the lowest indoor zone temperature is provided for heating.

The Global Ventilation Schedule is disabled. The supply fan is on, the return fan is on (where applicable), the outdoor air mixing dampers are in the 0 % outdoor air position, heating is enabled at full capacity and the cooling is disabled.

2.18. Rooftop Heating Stage Sequencing:

Room Controller PID, (generates a signal based on the room temperature and room setpoint from 0 %Clg to 100 %Clg), typically stage 1 heating is enabled at 25 %Clg PID signal and disabled at 50 %Clg PID signal and stage 2 heating is enabled at 5 %Clg PID signal and disabled at 25 %Clg PID signal.

2.19. Rooftop Economizer Sequencing:

The economizer signal goes from 0 % to 100 % as the Room Controller PID goes from 40 %Clg to 60 %Clg.

2.20. Rooftop Mechanical DX Cooling Stage Sequencing:

Room Controller PID, typically stage 1 cooling is enabled at 75 %Clg PID signal and disabled at 60 %Clg PID signal and stage 2 cooling is enabled at 95 %Clg PID signal and disabled at 60 %Clg PID signal).

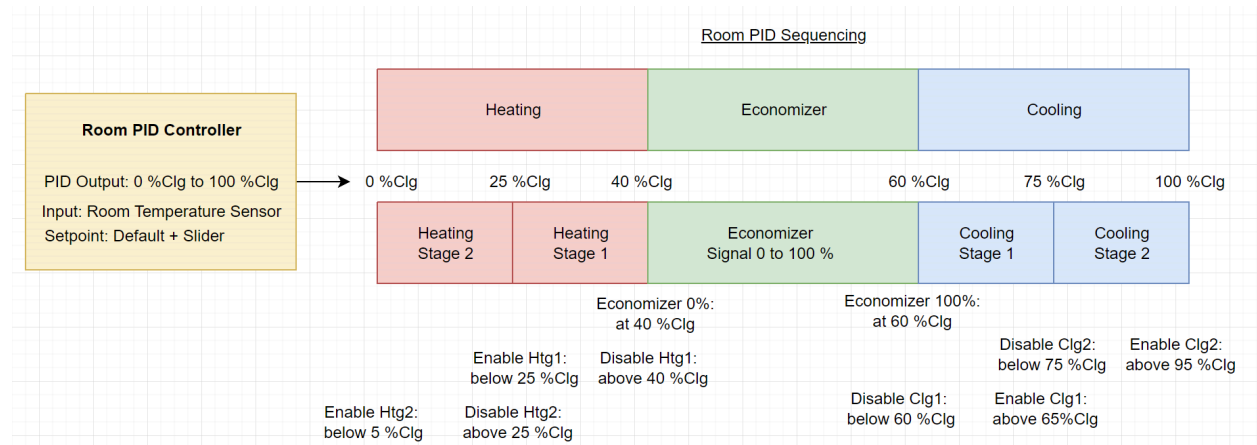

3. Equipment Specific Sequence of Operations:

3.1. VVT HVAC Rooftop Unit Sequence of Operations:

3.1.1. Discretionary Fire Alarm Shutdown Mode:

The supply fan is off, the return fan is off (where applicable) and power exhaust fan is off (where applicable), the outdoor air mixing dampers are in the 0% outdoor air position, heating is disabled and cooling is disabled. The VVT bypass damper is in the 100 % open position. The zone dampers are in the 50 % open position. This is not intended to replace the hard-wired fan shutdown provided by others when required by Code. Normal HVAC unit functions are auto restored on relay signal from the fire alarm panel reset.

3.1.2. Software Freeze-stat Shutdown Mode:

The duct/unit mounted supply air temperature sensor acts as a software freeze-stat (triggered below 1 °C after 3 minutes, restored above 5 °C after 3 minutes, and auto reset after 5 minute delay).

3.1.3. Unoccupied Mode:

Mode is active usually between 11:00 p.m. to 7:00 a.m. Monday to Friday and 24 hours Saturday and Sunday.

The system will be in Unoccupied Mode when not in Morning Warmup, Occupied or Standby modes.

The system will cycle between Idle State, Heating State or Pushbutton Override States to meet the demands from each state and return to the Idle State when the demands are satisfied.

3.1.3.1. (Idle State)

The supply fan is off, the return fan is off (where applicable) power exhaust fan is off (where applicable), the Global Ventilation Schedule is disabled, the outdoor air mixing dampers are in the 0 % outdoor air position, heating is disabled and cooling is disabled. The bypass damper is in the 100 % open position. The zone dampers are in the 50 % open position.

3.1.3.2. (Heating State)

System cycles on a call for unoccupied heating. A full call for (all stages or full heat modulation where applicable) heating until setpoint is reached.

The VVT HVAC unit supply air static pressure setpoint is increased by 20 %. Bypass damper(s) and associated zone damper(s) modulate to obtain setpoint.

Unoccupied Heating temperature nominally 16.0 °C space temperature setpoint with an increased space temperature setpoint to 17.0 °C at -10.0 °C Outdoor Air Temperature or lower and 18.0 °C at -20.0 °C Outdoor Air Temperature or lower (each adjustable)

Mechanical Cooling: Disabled

Free Cooling: Disabled

Global Ventilation Schedule: Disabled

3.1.3.3. (Push Button Override State)

The default room temperature setpoint remains unchanged.

Idle state of the unoccupied mode is exited if the override pushbutton is pressed, (for a minimum of 2 seconds) at any room sensor.

The associated system will switch to the Occupied Mode for 2 hours (adjustable).

Free Cooling: Disabled

Mechanical Cooling: Enabled

Global Ventilation: Enabled

The system returns to idle state in the unoccupied mode after the 2 hours after the pushbutton trigger has elapsed.

3.1.4. Morning Warmup Mode:

An optimized start, based on the time of day schedule, outdoor air temperature and the lowest indoor zone temperature is provided for heating.

The Global Ventilation Schedule is disabled. The supply fan is on, the return fan is on (where applicable), the outdoor air mixing dampers are in the 0 % outdoor air position, heating is enabled at full capacity and the cooling is disabled.

The VVT bypass damper(s) starts in the 100 % open position. The zone dampers start in the 50 % open position.

The optimized start program is to begin up to 105 minutes (adjustable) before the occupancy schedule to allow for morning warm up to bring the lowest zone temperature up to occupancy setpoint.

Free Cooling: Disabled

Mechanical Cooling: Disabled

Global Ventilation Schedule: Disabled

The system exits Morning Warmup Mode and continues into occupied mode when the lowest indoor zone temperature is warmed up to default room temperature setpoint.

3.1.5. Occupied Mode:

Time of day schedule, which starts the HVAC unit(s) along with an Optimum Start program usually between 7:00 a.m. and 4:00 p.m. Monday to Friday, when not overridden by a Holiday Schedule, Standby Occupancy Mode or Unoccupied Mode.

Global Ventilation Schedule is enabled.

HVAC unit fan status confirmed by current sensing device(s) or VFD feedback.
Fan operation: The supply fan and return fan (where applicable) run continuously.
Room heating temperature setpoint nominal: 21.5 °C +/- 1.0 °C (adjustable)
Room Free Cooling Enabled temperature setpoint nominal 22.5 °C +/-1.0 °C
Room mechanical cooling temperature setpoint nominal 24.5 °C +/- 1.0 °C (adjustable)
Global Ventilation Schedule: Enabled

3.1.6. Standby Occupancy Mode:

Time of day schedule starts the HVAC unit(s) usually between 4:00 p.m. and 11:00 p.m. Monday to Friday.
Minimum outdoor air is set to zero when the global ventilation schedule is off.
Fan operation: Supply fan and return fan (where applicable) runs only on a call from heating or cooling.
Ventilation normally set to zero (with a future provision to adjust).
Room heating temperature setpoint nominal: 21.5 °C +/- 1.0 °C (adjustable)
Room Mechanical Cooling temperature setpoint nominal 24.5 °C +/- 1.0 °C (adjustable)
Free Cooling: Disabled
Global Ventilation Schedule: Disabled

3.1.7. Zone Damper:

The room sensor modulates the zone damper between minimum and maximum settings to maintain (Occupied, Standby, or Unoccupied) Mode temperatures.
The setpoint is adjustable at the sensor.
The control is reverse acting when the supply temperature is more than 1 °C above room temperature and direct acting when the supply air temperature is more than 1 °C below room temperature.
If the system mode is different from the zone mode (e.g. system is in heating mode but zone requires cooling), the zone damper closes to a reduced minimum position to minimize overheating/overcooling.
A minimum of 5 minutes to changeover between Heating to Cooling Modes is required.

3.1.8. System Heating/Cooling Decision Process:

3.1.8.1. Enable Criteria:

The system mode is determined by the number of zones that deviate by 1.2 °C from their respective zone heating/cooling setpoints. The number of zones is "weighted" by the deviation from setpoint. If the total number of zones requesting heating outnumber (or are equal to) the total number of zones requesting cooling the system will go to Heating Enabled Mode and in reverse for Cooling Enabled Mode.

Once in Heating Enabled Mode or Cooling Enabled Mode, the reference zone becomes the zone of greatest call. The system will lock-in the selected mode until all zones are satisfied. If all zones are not satisfied within 20 minutes (60 minutes if all zones are in the same mode) the system will "unlock" and enable Forced Ventilation Mode.

The outdoor air temperature determines the heating or cooling priority.

3.1.8.2. Heating Enabled Mode

In Heating Enabled Mode, the highest priority zone calling for heating is given first priority. If there is any zone calling for cooling, this is given second priority.

3.1.8.3. Cooling Enabled Mode

In the Cooling Enabled Mode, the highest priority zone calling for cooling is given first priority. If any zone is calling for heating, this is given second priority.

3.1.8.4. Default Ventilation Mode

If there is neither a call for cooling or heating, the system is returned to the Ventilation Sequence

3.1.8.5. Forced Ventilation Mode

Every 20 minutes if the system is not satisfied (and 60 minutes if all zones are in the same mode) the system is switched to ventilation mode for 5 minutes

3.1.9. Ventilation Lockout (Sequence):

When the ventilation lockout switch, usually located in the Custodial Office, is engaged, all outdoor air dampers close, free cooling is disabled, and the system switches to Standby Occupancy Mode of operation.

3.1.10. Heating Sequence:

3.1.10.1. Outdoor Air Temperature used to determine Heating Enable Mode:

A set of thresholds that are user adjustable at a global (board wide) or local (site specific) level, triggers the heating enable mode based on the outdoor air temperature below the threshold. The threshold is further adjusted by a calendar schedule.
Typical default values are: 16 °C from September to May and 5 °C from June to August.

3.1.10.2. Default Setpoint:

When the Heating Mode is active, the default room temperature setpoint remains unchanged.

- 3.1.10.3. Call for Heating:
 Mechanical heating is used until the heating calls (from room controller PID or Night Setback thresholds) are satisfied. If the total number of zones requesting heating outnumber (or are equal to) the total number of zones requesting cooling, the system will go into Heating Mode.
 For Modulating Burners, (where applicable) 0 % signal (0 Volts) heating discharge temperature setpoint is at minimum discharge temperature (typically set on the rooftop unit to 17.0 °C). A 100 % signal (10 Volts) heating discharge temperature setpoint is at maximum discharge temperature setpoint (typically set on the rooftop unit to 35 °C).
Hydronic
 For Heating Valve, (where applicable) 0 % signal (10 Volts) closes the heating valve. A 100% signal (below 2 Volts) opens the heating valve.
Radiation Zone
 Where there is a zone served by radiation, the radiation valve opens (where applicable) and is to be substituted as the first stage of heating.
- 3.1.11. Cooling Sequence:
- 3.1.11.1. Outdoor Air temperature used to determine cooling enable mode:
 A set of thresholds that are user adjustable at a global (board wide) or local (site specific) level, triggers the cooling enable mode based on the outdoor air temperature exceeding the threshold. The threshold is further adjusted by a calendar schedule. Typical default values are: 18 °C from September to May and 21 °C from June to August.
- 3.1.11.2. Default Cooling Setpoint:
 When the cooling enable mode is active, the default room temperature setpoint is raised by 3 °C.
- 3.1.11.3. Call for Cooling:
 When Free Cooling is available, and a demand for cooling is in place, free cooling will be used first, and if the demand for cooling is still in place, mechanical cooling will be used until the cooling calls (from room controller PID) are satisfied. If the total number of zones requesting cooling outnumber the total number of zones requesting heating, the system will go into cooling mode.
- 3.1.12. Reference Zone Sequence:
 Once in heating or cooling mode, the reference zone becomes the zone with the greatest call. The system mode will lock-in in the selected mode until all zones are satisfied.
- 3.1.13. Forced Vent Sequence
 When Global Ventilation Schedule is Enabled: If any zone is deprived of ventilation air for more than 20 minutes, the system will unlock and go into Forced Ventilation Mode for 5 minutes, and then reselect the required mode of operation.
- 3.1.14. Slave Zones:
 Zones designated as slave zones without cooling (typically corridors) cannot request heating or cooling, but will utilize heating when available. Cooling is not available and locked out for slave no-cooling zones. Zones designated as slave zones with cooling (typically a retrofitted work room off a classroom) cannot request heating or cooling but will utilize heating or cooling when available. Slave zones with cooling are to be minimized.
- 3.1.15. System Heating Control:
 Stage 1 and Stage 2 heating are controlled from the reference zone as follows:
 Reference Zone Call for Heating
- | | |
|-------------|--------|
| Stage 1 On | 1.0 °C |
| Stage 1 Off | 0.5 °C |
| Stage 2 On | 1.5 °C |
| Stage 2 Off | 1.0 °C |
- Modulation: Heating is modulated (where applicable).
- 3.1.16. System Cooling Control:
 Stage 1 and Stage 2 cooling are controlled from the reference zone as follows:
 Reference Zone Call for Cooling
- | | |
|-------------|--------|
| Stage 1 On | 1.2 °C |
| Stage 1 Off | 0.5 °C |
| Stage 2 On | 1.5 °C |
| Stage 2 Off | 0.9 °C |
- Modulation: Cooling is modulated (where applicable).

- 3.1.17. Bypass Operation:
The supply air static pressure sensor modulates the bypass damper between minimum and maximum settings to maintain supply static pressure setpoint. Reduce the supply air static pressure setpoint during both Default and Forced Ventilation modes, typically 10 Pa for acoustic noise reduction. During Unoccupied Mode setback, increase supply air static pressure setpoint, typically 120 % of regular setpoint.
- 3.1.18. Ventilation Sequence:
The system operates in ventilation mode (no heating or cooling) under the following conditions: No zones are calling for heating or cooling. System is switching between heating and cooling (the system operates in ventilation mode for 5 minutes). One or more zones have been operating at a reduced minimum position for more than 20 minutes (system operates in Forced Ventilation Mode for 5 minutes).
- 3.1.19. Economizer Operation (and CO2 Demand Control Ventilation) :
- 3.1.19.1. During Occupied Mode, economizer operation will be substituted for first stage mechanical cooling when the outdoor air temperature and relative humidity are below the Free Cooling Setpoint Sequence of Operation. If the outdoor air temperature is below this free cooling setpoint the mixing dampers will be modulated open on a call for cooling to provide 'free' cooling.
- 3.1.19.2. Minimum outdoor air damper position signal may exceed the economizer signal. A typical value for minimum outdoor air damper position is 5 % outdoor air, (0 % when an associated stand alone ERV is present) which can vary based on use case of the occupied space based on ASHRAE 62.1 net occupiable floor area outdoor air rate.
- 3.1.19.3. For HVAC units with power exhaust, the exhaust fan runs when the outdoor air damper is more than 50 % open.
- 3.1.19.4. During morning warm-up, the outdoor air minimum position is set to zero.
- 3.1.19.5. During Unoccupied Mode and Standby Occupancy Mode, free cooling is unavailable.
- 3.1.19.6. During Occupied Mode, If the outdoor air temperature and relative humidity are above the Free Cooling Setpoint Sequence of Operation, the mixing dampers will be set to the minimum outdoor air threshold unless otherwise required under ASHRAE 62.1 Ventilation Rate Procedure - net occupiable floor area outdoor air rate (w/ CO₂ demand controlled ventilation reset).
- 3.1.19.7. Each return air duct-mounted or space mounted CO₂ sensor acts as a high limit and will increase the amount of minimum outdoor air, to a maximum of 40% outdoor air as the CO₂ level increases from 1100 ppm (1000 ppm to 1200 ppm over a ramped 15 minute period).
- 3.1.19.8. CO₂ levels are automatically logged at 10 minute intervals (adjustable).
- 3.1.20. Additional Rooms Partition Switch
Any additional room(s) (ie. Music Rooms) that are separated by a partition wall, will disable mechanical cooling (where applicable) for the associated units that serve the additional room(s). If the Music Room wall is open to the Gym, mechanical cooling serving the Music Room is disabled. Partition switch and lamacoid label to be provided above Music Room Sensor by the Building Automation Contractor. Label to read "No Cooling when Partition is Open to Gym".
- 3.1.21. Limits and Safeties:
- 3.1.21.1. The maximum outdoor air damper position is limited based on the outdoor air temperature to prevent excessively low supply air temperature. At -15°C or below, outdoor air temperature, the maximum outdoor air damper position will be 0% open and at 10°C outdoor air temperature, the maximum outdoor air damper position will be 100%.
- 3.1.21.2. The maximum outdoor air damper position is limited based on the outdoor air temperature to prevent excessively high supply air temperature. At 30°C outdoor air temperature and above, the maximum outdoor air damper position will be 0% open and at 10°C outdoor air temperature, the maximum outdoor air damper position will be 100%
- 3.1.21.3. The mixed air temperature sensor acts as a low limit to ensure temperature does not fall below setpoint (typically 11 °C). In applications where the mixed air sensor is located after the DX cooling coil, the setpoint is reduced (to typically 5 °C) when DX cooling is enabled.
- 3.1.21.4. The duct mounted supply air temperature sensor acts as a high limit for each stage of heating (for stage 1: disable above 60°C , and enable below 50°C, for stage 2: disable above 55°C and enable below 45°C) and a low limit for each stage of cooling (for stage 1: disable DX1 below 5°C and enable DX1 above 10 °C, for stage 2: below 8 °C disable DX2 and above 13°C enable DX2).
- 3.1.21.5. The supply air temperature sensor acts as a software freeze-stat (triggered below 1 °C for 1 minute, restored above 5 °C for 1 minute), auto reset after 5 minute delay.
- 3.1.21.6. The supply fan has a delay-off time of 90 seconds.
- 3.1.21.7. The DX cooling has a minimum-off time of 5 minutes.
- 3.1.21.8. DX cooling is disabled when the outdoor air temperature is below global DX disable setpoint or when fan is off.
- 3.1.21.9. Gas heating is disabled when the outdoor air temperature is above the global heating disable setpoint or when the fan is off.
- 3.1.21.10. Stage 1 gas heating (where applicable for units with multiple stages of heating) has a minimum run time of 3 minutes.
- 3.1.21.11. During Default and or Forced Ventilation Modes, if the supply air temperature falls below 15 °C for more than two minutes, stage 1 heating will turn on until supply air temperature exceeds 25 °C (to improve comfort).
- 3.1.21.12. The default zone setpoint is increased by 3°C when mechanical cooling is enabled (providing heating is disabled). The standard mechanical cooling setpoint will be limited to a (minimum of 23.5 °C - adjustable).

- 3.1.21.13. When the ventilation lockout switch (usually located at the custodial office) is engaged, the outdoor air dampers close, free cooling is disabled, and the system switches to Standby Occupancy Mode.
- 3.1.21.14. Minimum outdoor air is provided when enabled by the Global Ventilation Schedule.
- 3.1.21.15. The return air carbon dioxide sensor acts as a high limit to increase the amount of minimum outdoor air from 0 to 40 % as the reading increases from 1000 ppm to 1200 ppm.
- 3.1.21.16. Cooling cannot turn on until heating has been off for a minimum of 5 minutes.
- 3.1.21.17. During Occupied Mode, and the outdoor air is above -1°C, heating stage 2 (where applicable) has a delay-on time of 15 minutes, except when the outdoor air temperature is below -3°C with a +2°C deadband.
- 3.1.21.18. Minimum outdoor air is set to zero when the Global Ventilation Schedule is off.

3.1.22. Alarms:

An alarm will be generated upon the following conditions:

- 3.1.22.1. Fan status does not match the start/stop signal.
- 3.1.22.2. Mixed air temperature too high alarm, (triggered above 50 °C and restored below 48 °C) or too low alarm (triggered below 5 °C and restored above 7°C). Low mixed air temperature alarm set to lower thresholds when Mixed Air Temperature sensor is installed after the DX/cooling coil.
- 3.1.22.3. Supply air temperature too high alarm (triggered above 65 °C and restored below 63 °C) or too low alarm (triggered below 5 °C and restored above 7 °C).
- 3.1.22.4. Space temperature too high alarm (triggered above 42 °C and restored below 40 °C) for non-cooling systems, (triggered above 38°C and restored above 36°C) for cooling systems.
- 3.1.22.5. Space temperature too low alarm (triggered below 14 °C and restored above 16 °C).
- 3.1.22.6. Supply air static pressure too low alarm (below 5 Pa and restored below 15 Pa) or too high alarm (above 240 Pa and restored below 230 Pa), with a 30 minute delay.
- 3.1.22.7. Weekly fan runtime limit exceeded.
- 3.1.22.8. Return air CO₂ too high alarm (triggered above 1700 ppm and restored below 1650 ppm) or too low alarm (triggered below 250 and restored above 300 ppm) with a 15 minute delay.
- 3.1.22.9. Software freeze-stat tripped.

3.2. Single Zone HVAC Rooftop Sequence of Operations: (with Heating, Ventilating and Mechanical Cooling)

3.2.1. Discretionary Fire Alarm Shutdown Mode:

The supply fan is off, the return fan is off (where applicable) and power exhaust fan is off (where applicable), the outdoor air mixing dampers are in the 0 % outdoor air position, heating is disabled and cooling is disabled. This is not intended to replace the hard-wired fan shutdown provided by others when required by Code. Normal HVAC unit functions are auto restored on relay signal from the fire alarm panel reset.

3.2.2. Freeze-stat Shutdown Mode(s):

3.2.2.1. Software

The duct/unit mounted supply air temperature sensor acts as a software freeze-stat (triggered below 1 °C after 1 minute delay, restored above 5 °C after 5 minute delay).

3.2.2.2. Hard-Wired

In addition BAS monitors status of the duct mounted hard wired freeze-stat (provided by others, where applicable) that shuts down the AHU fan(s) and spring closes the outside air damper(s) if the air temperature leaving the heating coil falls below the freeze-stat setpoint.

3.2.3. Unoccupied Mode:

Mode is active usually between 11:00 p.m. to 7:00 a.m. Monday to Friday and 24 hours Saturday and Sunday.

The system will be in Unoccupied Mode when not in Morning Warmup, Occupied or Standby modes.

The system will cycle between Idle State, Heating State and Pushbutton Override States to meet the demands from each state and return to the Idle State when the demands are satisfied.

3.2.3.1. (Idle State)

The supply fan is off, the return fan is off (where applicable), the power exhaust fan is off (where applicable), the Global Ventilation Schedule is disabled, the outdoor air mixing dampers are in the 0 % outdoor air position, heating is disabled and cooling is disabled.

3.2.3.2. (Heating State)

System cycles on a call for unoccupied heating (which is triggered by the System Minimum Zone Temperature falling below the Unoccupied Heating Room Setpoint).

Supply fan cycles on, associated exhaust or return fan cycles on (where applicable).

A full call for (all stages or full heat modulation where applicable) heating until setpoint is reached.

For modulating burners, (where applicable) 0 % signal (0 Volts) heating discharge temperature setpoint is at minimum discharge temperature (typically set on the rooftop unit to 17 °C). A 100 % signal (10 Volts) heating discharge temperature setpoint is at maximum discharge temperature setpoint (typically set on the rooftop unit to 35 °C).

Unoccupied Heating Room Temperature Setpoint nominally 16.0 °C space temperature setpoint with an increased space temperature setpoint to 17.0 °C at -10.0 °C Outdoor Air Temperature or lower and 18.0 °C at -20.0 °C Outdoor Air Temperature or lower (each adjustable)

Mechanical Cooling: Disabled

Free Cooling: Disabled

Global Ventilation Schedule: Disabled

3.2.3.3. (Push Button Override State)

The default room temperature setpoint remains unchanged.

Idle state of the unoccupied mode is exited if the override pushbutton is pressed, (for a minimum of 2 seconds) at any room sensor.

The associated system will switch to the Occupied Mode for 2 hours (adjustable).

Free Cooling: Disabled

Mechanical Cooling: Enabled

Global Ventilation: Enabled

The system returns to idle state in the unoccupied mode after the 2 hours after the pushbutton trigger has elapsed.

3.2.4. Morning Warmup Mode:

An optimized start, based on the time of day schedule, outdoor air temperature and the lowest indoor zone temperature is provided for heating.

The Global Ventilation Schedule is disabled. The supply fan is on, the return fan is on (where applicable), the outdoor air mixing dampers are in the 0 % outdoor air position, heating is enabled at full capacity and the cooling is disabled.

The optimized start program is to begin up to 105 minutes (adjustable) before the occupancy schedule to allow for morning warm up to bring the lowest zone temperature up to occupancy setpoint.

Free Cooling: Disabled

Mechanical Cooling: Disabled

Global Ventilation Schedule: Disabled

The system exits Morning Warm Up Mode and continues into occupied mode when the lowest indoor zone temperature is warmed up to default room temperature setpoint.

3.2.5. Occupied Mode:

Time of day schedule, which starts the unit along with an Optimum Start program usually between 7:00 a.m. and 4:00 p.m. Monday to Friday, when not overridden by a Holiday Schedule, Standby Occupancy Mode or Unoccupied Mode.

Global Ventilation Schedule is enabled.

HVAC unit fan status confirmed by current sensing device(s) or VFD feedback.

Fan operation: The supply fan and return fan (where applicable) run continuously.

Room Heating Temperature Setpoint nominal: 21.5 °C +/- 1.0 °C (adjustable)

Room Free Cooling Enabled Temperature Setpoint nominal 22.5 °C +/-1.0 °C

Room Mechanical Cooling Temperature Setpoint nominal 24.5 °C +/- 1.0 °C (adjustable)

Global Ventilation Schedule: Enabled

3.2.6. Standby Occupancy Mode:

Time of day schedule starts the HVAC unit(s) usually between 4:00 p.m. and 11:00 p.m. Monday to Friday.

Minimum outdoor air is set to zero (with future provision to adjust) when the global ventilation schedule is off.

Fan operation: Supply fan and return fan (where applicable) runs only on a call from heating or cooling.

Ventilation normally set to zero (with a future provision to adjust).

Room Heating Temperature Setpoint nominal: 21.5 °C +/- 1.0 °C (adjustable)

Room Mechanical Cooling Temperature Setpoint nominal 24.5 °C +/- 1.0°C (adjustable)

Free Cooling: Disabled

Global Ventilation Schedule: Disabled

3.2.7. Ventilation Lockout (Sequence):

When the ventilation lockout switch, usually located in the Custodial Office, is engaged, all outdoor air dampers close, free cooling is disabled, and the system switches to Standby Occupancy Mode of operation.

3.2.8. Heating Sequence:

3.2.8.1. Outdoor Air Temperature used to determine Heating Enable Mode:

A set of thresholds that are user adjustable at a global (board wide) or local (site specific) level, triggers the heating enable mode based on the Outdoor Air Temperature below the threshold. The threshold is further adjusted by a calendar schedule.

Typical default values are: 16 °C from September to May and 5 °C from June to August.

3.2.8.2. Default Setpoint:

When the Heating Mode is active, the default room temperature setpoint remains unchanged.

3.2.8.3. Call for Heating:

Mechanical heating is used until the heating calls (from room controller PID, typically stage 1 heating is enabled at 25 %Clg PID signal and disabled at 50 %Clg PID signal and stage 2 heating is enabled at 5 %Clg PID signal and disabled at 50 %Clg PID signal or Night Setback thresholds) are satisfied.

For Modulating Burners, (where applicable) 0 % signal (0 Volts) heating discharge temperature setpoint is at minimum discharge temperature (typically set on the rooftop unit to 17 °C). A 100 % signal (10 Volts) heating discharge temperature setpoint is at maximum discharge temperature setpoint (typically set on the rooftop unit to 35 °C).

The room temperature sensor regulates heating output to maintain the occupied heating setpoint. Local setpoint adjustment is provided. The power exhaust fan or return fan (if applicable) cycles based on the rooftop economizer position.

Hydronic

For Heating Valve, (where applicable) 0 % signal (10 Volts) closes the heating valve. A 100% signal (below 2 Volts) opens the heating valve.

Radiation Zone

Where there is a zone served by radiation, the radiation valve opens (where applicable) and is to be substituted as the first stage of heating.

3.2.9. Cooling Sequence:

3.2.9.1. Outdoor Air Temperature used to determine cooling enable mode:

A set of thresholds that are user adjustable at a global (board wide) or local (site specific) level, triggers the cooling enable mode based on the Outdoor Air Temperature exceeding the threshold. The threshold is further adjusted by a calendar schedule. Typical default values are: 18°C from May to September-and 21°C from June to August.

3.2.9.2. Default Setpoint:

When the cooling enable mode is active, the default room temperature setpoint is raised by 3 °C.

3.2.9.3. Call for Cooling:

When Free Cooling is available, and a demand for cooling is in place, free cooling will be used first, and if the demand for cooling is still in place, mechanical cooling will be used until the cooling calls (from room controller PID) are satisfied.

The room temperature sensor also modulates the mixing dampers (for free cooling) to maintain the occupied free cooling setpoint.

3.2.10. Ventilation Sequence:

The system operates in ventilation mode (no heating or cooling) under the following conditions: System is switching between heating and cooling

3.2.11. Economizer Operation (and CO₂ Demand Control Ventilation) :

3.2.11.1. During Occupied Mode, economizer operation will be substituted for first stage mechanical cooling when the outdoor air temperature and relative humidity are below the Free Cooling Setpoint Sequence of Operation. If the outdoor air temperature is below this free cooling setpoint the mixing dampers will be modulated open on a call for cooling to provide 'free' cooling.

3.2.11.2. Minimum outdoor air damper position signal may exceed the economizer signal. A typical value for minimum outdoor air damper position is 5 % outdoor air, (0 % when an associated stand alone ERV is present) which can vary based on use case of the occupied space based on ASHRAE 62.1 net occupiable floor area outdoor air rate.

3.2.11.3. For HVAC units with power exhaust, the exhaust fan runs when the outdoor air damper is more than 50% open.

3.2.11.4. During morning warm-up, the outdoor air minimum position is set to zero.

3.2.11.5. During Unoccupied Mode and Standby Occupancy Mode, free cooling is unavailable.

3.2.11.6. During Occupied Mode, If the outdoor air temperature and relative humidity are above the Free Cooling Setpoint Sequence of Operation, the mixing dampers will be set to the minimum outdoor air threshold unless otherwise required under ASHRAE 62.1 Ventilation Rate Procedure - net occupiable floor area outdoor air rate (w/ CO₂ demand controlled ventilation reset).

3.2.11.7. Each return air duct-mounted or space mounted CO₂ sensor acts as a high limit and will increase the amount of minimum outdoor air, to a maximum of 40 % outdoor air as the CO₂ level increases from 1100 ppm (1000 ppm to 1200 ppm over a ramped 15 minute period).

3.2.11.8. Additional Rooms Partition Switch

Any additional room(s) (ie. Music Rooms) that are separated by a partition wall, will disable mechanical cooling (where applicable) for the associated units that serve the additional room(s). If the Music Room wall is open to the Gym, mechanical cooling serving the Music Room is disabled. Partition switch and lamacoid label to be provided above Music Room Sensor by the Building Automation Contractor. Label to read "No Cooling when Partition is Open to Gym".

3.2.12. Limits and Safeties

3.2.12.1. The maximum outdoor air damper position is limited based on the outdoor air temperature to prevent excessively low supply air temperature during startup. At -20 °C outdoor air temperature, and below, the maximum outdoor air damper position will be 0 % open and at 10 °C outdoor air temperature the maximum outdoor air damper position will be 100 %.

- 3.2.12.2. The mixed air temperature sensor acts as a low limit to ensure temperature does not fall below setpoint (typically 11 °C). In applications where the mixed air sensor is located after the DX cooling coil, the setpoint is reduced (to typically 5 °C) when DX cooling is enabled.
- 3.2.12.3. The supply air temperature sensor acts as a high limit for each stage of heating (for stage 1: disable above 60 °C , and enable below 50 °C, for stage 2: disable above 55 °C and enable below 45 °C) and a low limit for each stage of cooling (for stage 1: disable DX1 below 5 °C and enable DX1 above 10 °C, for stage 2: below 8 °C disable DX2 and above 13 °C enable DX2).
- 3.2.12.4. The supply air temperature sensor acts as a software freezestat (trigger above 1 °C and restore above 5 °C) after 1 minute delay, auto reset after 5 minute delay).
- 3.2.12.5. The supply fan has a delay-off time of 90 seconds.
- 3.2.12.6. The DX cooling has a minimum-off time of 5 minutes.
- 3.2.12.7. DX cooling is disabled when the outdoor air temperature is below global DX disable setpoint (typically 2 °C below Cooling Enable setpoint) or when fan is off.
- 3.2.12.8. Gas heating is disabled when the outdoor air temperature is above the global heating disable setpoint (typically 2 °C above Heating Enable setpoint) or when the fan is off.
- 3.2.12.9. Stage 1 gas heating (where applicable for units with multiple stages of heating) has a minimum run time of 3 minutes.
- 3.2.12.10. Minimum outdoor air is provided when enabled by the global minimum outdoor air time schedule. The minimum outdoor air is adjustable from the graphic and is typically a default of 10 % open outdoor damper position.
- 3.2.12.11. The return air carbon dioxide sensor acts as a high limit to increase the amount of minimum outdoor air from 0 % to 40 % as the reading increases from 1000 ppm to 1200 ppm.
- 3.2.12.12. Cooling cannot turn on until heating has been off for a minimum of 5 minutes.
- 3.2.12.13. During Occupied Mode, and the outdoor air is above -1 °C, heating stage 2 (where applicable) has a delay-on time of 15 minutes, except when the outdoor air temperature is below -3 °C with a +2 °C deadband.
- 3.2.12.14. The default room temperature setpoint is increased by 2 °C when mechanical cooling is enabled (providing heating is disabled). The standard mechanical cooling setpoint will be limited to a minimum of 23.5 °C.
- 3.2.12.15. When the ventilation lockout switch (usually located at the custodial office) is engaged, the outdoor air dampers close, free cooling is disabled, and the system switches to standby mode of operation.
- 3.2.12.16. Minimum outdoor air is set to zero when the global ventilation schedule is off (standby occupancy).
- 3.2.12.17. Discretionary Fire Alarm Shutdown Mode to be enabled on the fire alarm status.

3.2.13. Alarms:

An alarm will be generated upon the following conditions:

- 3.2.13.1. Fan status does not match the start/stop signal.
- 3.2.13.2. Mixed air temperature too high alarm, (triggered above 50 °C and restored below 48 °C) or too low alarm (triggered below 5 °C and restored above 7 °C). Low mixed air temperature alarm set to lower thresholds when Mixed Air Temperature sensor is installed after the DX/cooling coil.
- 3.2.13.3. Supply air temperature too high alarm (triggered above 65 °C and restored below 63 °C) or too low alarm (triggered below 5 °C and restored above 7 °C).
- 3.2.13.4. Space temperature too high alarm (triggered above 42 °C and restored below 40 °C) for non-cooling systems, (triggered above 38 °C and restored above 36 °C) for cooling systems.
- 3.2.13.5. Space temperature too low alarm (triggered above 14 °C and restored above 16°C).
- 3.2.13.6. Weekly fan runtime limit exceeded.
- 3.2.13.7. Return air CO₂ too high alarm (triggered above 1700 ppm and restored below 1650 ppm) or too low alarm (triggered below 250 and restored above 300 ppm) with a 15 minute delay.
- 3.2.13.8. Software freezestat tripped.

3.3. Gym HV Rooftop Sequence of Operations: (with Heating and Ventilating Only)

3.3.1. Discretionary Fire Alarm Shutdown Mode:

The supply fan is off, the return fan is off (where applicable) and power exhaust fan is off (where applicable), the outdoor air mixing dampers are in the 0 % outdoor air position, heating is disabled. This is not intended to replace the hard-wired fan shutdown provided by others when required by Code. Normal HV unit functions are auto restored on relay signal from the fire alarm panel reset.

3.3.2. Software Freezestat Shutdown Mode:

The duct/unit mounted supply air temperature sensor acts as a software freezestat (triggered below 1°C after 3 minutes, restored above 5°C after 3 minutes, and auto reset after 5 minute delay).

3.3.3. Unoccupied Mode:

Mode is active usually between 11:00 p.m. to 7:00 a.m. Monday to Friday and 24 hours Saturday and Sunday.

The system will be in Unoccupied Mode when not in Morning Warmup, Occupied or Standby modes.

The system will cycle between Idle State, Heating State Pushbutton Override States to meet the demands from each state and return to the Idle State when the demands are satisfied.

3.3.3.1. (Idle State)

The supply fan is off, the return fan is off (where applicable), the power exhaust fan is off (where applicable), Global Ventilation Schedule is disabled, the outdoor air mixing dampers are in the 0 % outdoor air position, the heating is disabled.

3.3.3.2. (Heating State)

System cycles on a call for unoccupied heating. A full call for (all stages or full heat modulation where applicable) heating until setpoint is reached.

Heating temperature nominally 16.0 °C space temperature setpoint with an increased space temperature setpoint to 17.0 °C at -10.0 °C OAT or lower and 18.0 °C at -20.0 °C OAT or lower (each adjustable)

Free Cooling: Disabled

Global Ventilation Schedule: Disabled

3.3.3.3. (Push Button Override State)

If the override pushbutton is pressed, at any gym sensor, the associated system will switch to the Occupied Mode for 2 hours (adjustable). With outdoor air ventilation enabled.

3.3.4. Morning Warmup Mode:

An optimized start, based on the time of day schedule, outdoor air temperature and the indoor zone temperature is provided for heating.

The global Global Ventilation Schedule is disabled. The supply fan is on, the return fan is on (where applicable), the outdoor air mixing dampers are in the 0 % outdoor air position and heating is enabled at full capacity.

The optimized start program is to begin up to 105 minutes (adjustable) before the occupancy schedule to allow for morning warm up to bring the lowest space temperature up to occupancy setpoint.

3.3.5. Occupied Mode:

Time of day schedule, which starts the unit along with an Optimum Start program usually between 7:00 a.m. and 4:00 p.m. Monday to Friday, when not overridden by a Holiday Schedule, Standby Occupancy Mode or Unoccupied Mode.

Global Ventilation Schedule is enabled.

HV unit fan status confirmed by current sensing device(s) or VFD feedback.

Fan operation: The supply fan and return fan (where applicable) run continuously.

Room heating temperature nominal: 21.5 °C +/- 1.0 °C (adjustable, 2.0 °C for gyms)

For modulating burners, (where applicable) 0 % signal (0 Volts) heating discharge temperature setpoint is at minimum discharge temperature (typically set on the HV unit to 17 °C). A 100 % signal (10 Volts) heating discharge temperature setpoint is at maximum discharge temperature setpoint (typically set on the HV unit to 35 °C).

Room Free Cooling Enabled temperature nominal 22.0 °C +/-1.0 °C (adjustable, 2.0 °C for gyms)

3.3.6. Standby Occupancy Mode:

Time of day schedule starts the unit(s) usually between 4:00 p.m. and 11:00 p.m. Monday to Friday. Minimum Outdoor Air is set to zero when the Global Ventilation Schedule is off. Supply fan and return fan (where applicable) runs only on a call from heating.

Ventilation normally set to zero (with a future provision to adjust).

Room heating temperature nominal: 21.5 °C +/- 1.0°C (adjustable, 2.0 °C for gyms)

Room Free Cooling: Disabled

Global Ventilation Schedule: Disabled

3.3.7. Ventilation Lockout (Sequence):

When the ventilation lockout switch, usually located in the Custodial Office, is engaged, all outdoor air dampers close, free cooling is disabled, and the system switches to Standby Occupancy Mode of operation.

3.3.8. Heating Sequence

3.3.8.1. Outdoor Air Temperature used to determine Heating Enabled Mode:

A set of thresholds that are user adjustable at a Global (board wide) or Local (site specific) level, triggers the heating enable mode based on the outdoor air temperature below the threshold. The threshold is further adjusted by a calendar schedule.

Typical default values are: 16 °C from September to May and 5 °C from June to August.

3.3.8.2. Default Setpoint:

When the Heating Mode is active, the default room temperature setpoint remains unchanged.

3.3.8.3. Call for Heating:

Heating is used until the heating calls (from room controller PID or unoccupied heating thresholds) are satisfied.

For modulating burners, (where applicable) 0 % signal (0 Volts) heating discharge temperature setpoint is at minimum discharge temperature (typically set on the rooftop unit to 17 °C). A 100 % signal (10 Volts) heating discharge temperature setpoint is at maximum discharge temperature setpoint (typically set on the rooftop unit to 35 °C).

The room temperature sensor regulates heating output to maintain the occupied heating setpoint. Local setpoint adjustment is provided. The power exhaust fan or relief fan (if applicable) cycles based on the rooftop economizer position.

3.3.9. Economizer Operation (and CO₂ Demand Control Ventilation):

- 3.3.9.1. During Occupied Mode, economizer operation will be substituted for mechanical cooling when the outdoor air temperature and relative humidity are below the Free Cooling Setpoint Sequence of Operation. If the outdoor air temperature is below this free cooling setpoint the mixing dampers will be modulated open on a call for cooling to provide 'free' cooling.
- 3.3.9.2. Minimum outdoor air damper position signal may exceed the economizer signal. A typical value for minimum outdoor air damper position is 5 % outdoor air, which can vary based on use case of the occupied space based on ASHRAE 62.1 net occupiable floor area outdoor air rate.
- 3.3.9.3. For HV units with power exhaust, the exhaust fan runs when the outdoor air damper is more than 50 % open.
- 3.3.9.4. During morning warm-up, the outdoor air minimum position is set to zero.
- 3.3.9.5. During Unoccupied Mode and Standby Occupancy Mode, free cooling is unavailable.
- 3.3.9.6. During Occupied Mode, If the outdoor air temperature and relative humidity are above the Free Cooling Setpoint Sequence of Operation, the mixing dampers will be set to the minimum outdoor air threshold unless otherwise required under ASHRAE 62.1 Ventilation Rate Procedure - net occupiable floor area outdoor air rate (w/ CO₂ demand controlled ventilation reset).
- 3.3.9.7. Each return air duct-mounted or space mounted CO₂ sensor acts as a high limit and will increase the amount of minimum outdoor air, to a maximum of 40 % outdoor air as the CO₂ level increases from 1100 ppm (1000 ppm to 1200 ppm over a ramped 15 minute period).

3.3.10. Gym Partition Switch

The gym partition position switch (where applicable for multiple gyms) indicates whether the dividing wall is open or closed. If the wall is open, the two rooftop units (where applicable) control to an average room temperature setpoint. If the wall is closed, the two rooftop units (where applicable) operate autonomously. Gym partition switch to be provided by the Building Automation Contractor.

3.3.11. Additional Rooms Partition Switch

Any additional room(s) (ie. Music Rooms) that are separated by a partition wall, will disable mechanical cooling (where applicable) for the associated units that serve the additional room(s). If the Music Room wall is open to the Gym, mechanical cooling serving the Music Room is disabled. Partition switch and lamacoid label to be provided above Music Room Sensor by the Building Automation Contractor. Label to read "No Cooling when Partition is Open to Gym".

3.3.12. Limits and Safeties

- 3.3.12.1. The maximum outdoor air damper position is limited based on the outdoor air temperature to prevent excessively low supply air temperature during startup. At -20 °C outdoor air temperature, and below, the maximum outdoor air damper position will be 0 % open and at 10 °C outdoor air temperature the maximum outdoor air damper position will be 100 %.
- 3.3.12.2. The mixed air temperature sensor acts as a low limit to ensure temperature does not fall below setpoint (typically 11°C).
- 3.3.12.3. The supply air temperature sensor acts as a high limit for each stage of heating (for stage 1: disable above 60 °C , and enable below 50 °C, for stage 2: disable above 55 °C and enable below 45 °C) and a low limit for each stage of cooling (for stage 1: disable DX1 below 5 °C and enable DX1 above 10 °C, for stage 2: below 8 °C disable DX2 and above 13 °C enable DX2).
- 3.3.12.4. The duct mounted supply air temperature sensor acts as a software freezestat (triggered below 1 °C, restored above 5 °C), 1 minute delay, auto reset after 5 minute delay).
- 3.3.12.5. The supply fan has a delay-off time of 90 seconds.
- 3.3.12.6. Gas heating is disabled when the outdoor air temperature is above the global heating disable setpoint (typically 18 °C) or when the fan is off.
- 3.3.12.7. Stage 1 gas heating (where applicable for staged heating) has a minimum run time of 3 minutes.
- 3.3.12.8. Minimum outdoor air is provided when enabled by the global minimum outdoor air time schedule. The minimum outdoor air is adjustable from the graphic and is typically a default of 10 % open outdoor damper position.
- 3.3.12.9. The return air carbon dioxide sensor acts as a high limit to increase the amount of minimum outdoor air damper position from 0 % to 40 % as the return air carbon dioxide reading increases from 1000 ppm to 1200 ppm.
- 3.3.12.10. During Occupied Mode, and the outdoor air is above -1 °C, heating stage 2 (where applicable) has a delay-on time of 15 minutes, except when the outdoor air temperature is below -3 °C with a +2 °C deadband.
- 3.3.12.11. The default space setpoint is increased by 2 °C when free cooling is enabled (providing heating is disabled). The standard cooling setpoint will be limited to a minimum of 23.5°C.
- 3.3.12.12. When the ventilation lockout switch (usually located at the custodial office) is engaged, the outdoor air dampers close, free cooling is disabled, and the system switches to standby mode of operation.
- 3.3.12.13. Minimum outdoor air is set to zero when the global ventilation schedule is off (standby occupancy).
- 3.3.12.14. Discretionary Fire Alarm Shutdown Mode to be enabled on the fire alarm status.

3.3.13. Alarms:

An alarm will be generated upon any of the following conditions:

- 3.3.13.1. Fan status does not match the start/stop signal.

- 3.3.13.2. Mixed air temperature too high alarm (triggered above 50 °C restored below 48 °C) or too low alarm (triggered below 5 °C and restored above 7 °C). Supply air temperature too high alarm (triggered above 65 °C and restored below 63 °C) or too low alarm (triggered below 5 °C and restored above 7 °C)
- 3.3.13.3. Space temperature too high alarm (triggered above 42 °C and restored below 40 °C) for non-cooling systems, (triggered above 38 °C and restored below 36 °C) for cooling systems.
- 3.3.13.4. Space temperature too low alarm (triggered below 14 °C and restored above 16 °C).
- 3.3.13.5. Weekly fan runtime limit exceeded.
- 3.3.13.6. Return air CO₂ too high alarm (triggered above 1700 ppm and restored below 1650 ppm) or too low alarm (triggered below 250 ppm and restored above 300 ppm).
- 3.3.13.7. Software freezestat tripped

3.4. HRV and ERV Unit Sequence of Operations:

3.4.1. Discretionary Fire Alarm Shutdown Mode:

The supply fan is off, the exhaust fan is off, all the outside air dampers spring closed to the 0 % outdoor air position. This is not intended to replace the hard-wired fan shutdown provided by others when required by Code. Normal HRV / ERV unit functions are auto restored on relay signal from the fire alarm panel reset.

3.4.2. Software Freezestat Shutdown Mode:

The duct/unit mounted supply air temperature sensor downstream of the wheel/core acts as a software freezestat (triggered below 1 °C for 3 minutes, restored above 5 °C for 3 minutes, and auto reset after 5 minute delay).

3.4.3. Unoccupied Mode:

The exhaust fan is off, the supply fan is off, and the intake and exhaust dampers are spring return.

3.4.4. Morning Warmup Mode:

Not applicable. Same as Unoccupied mode.

3.4.5. Occupied Mode:

The supply and exhaust fans run continuously when any associated rooftop unit is operating in Occupied Mode, the economizers are less than 30 % outside air dampers position and the Global Ventilation Schedule is on. Fan status indication is from the current sensing device(s). Fan operation: The supply fan (except for freeze protection) and exhaust fan run continuously.

3.4.6. Econo Mode:

3.4.7. The Econo Mode will be enabled when the outside air damper position across all associated HVAC / HV units are equal to or greater than 30 % for more than 15 minutes, indicating that the HVAC / HV units are in free cooling mode. The HRV / ERV will be disabled on a call from BAS and all associated dampers shall spring closed.

3.4.8. If any associated outside air damper position across all associated HVAC units are equal to or less than 30 % for more than 15 minutes the Econo Mode will be disabled and HRV / ERV unit operation will resume.

3.4.9. The Econo Mode will not be applicable to HRV / ERV units serving washrooms.

3.4.10. Standby Occupancy Mode:

Not applicable. Same as Unoccupied Mode.

3.4.11. Ventilation Lockout (Sequence):

When the ventilation lockout switch, usually located in the Custodial Office, is engaged, supply and exhaust fans stop, all dampers spring close, and the system switches to Unoccupied Mode of operation.

3.4.12. Limits and Safeties

3.4.12.1. Defrost control provided by the ERV/HRV manufacturer. The internal frost controls (supply fan stops, exhaust fan defrosts the core).

3.4.12.2. Systems that have electric or hydronic reheat are to be avoided.

3.4.12.3. The supply air sensor acts as a software freezestat (triggered below 1 °C for 3 minutes, restored above 5 °C for 3 minutes, and auto reset after 5 minute delay).

3.4.12.4. The supply and exhaust fans stop on a fire alarm condition.

3.4.12.5. If the mixed air damper position exceeds 30 % outdoor air on all associated HVAC units, the HRV/ERV supply and exhaust fans stop. Not applicable to units that serve washrooms.

3.4.12.6. If deemed required, ERV/HRV's exhaust fans may need to continue to run for systems serving washroom exhausts when the system is not in occupied mode. (Revisit issue with consultants)

3.4.13. Alarms:

An alarm will be generated upon the following conditions:

- 3.4.13.1. After 15 minute delay (adjustable), supply fan status does not match the start/stop signal.
- 3.4.13.2. After 15 minute delay (adjustable), exhaust fan status does not match the start/stop signal.
- 3.4.13.3. Supply air temperature too high alarm (triggered above 35 °C and restored below 33 °C) or too low alarm (triggered 1 °C and restored below 3 °C)
- 3.4.13.4. Return air temperature too high alarm (triggered above 40 °C and restored below 38 °C) or too low alarm (triggered above 14 °C and restored below 15 °C)
- 3.4.13.5. Exhaust air temperature too high alarm (triggered above 40 °C and restored below 38 °C) or too low alarm (triggered below -1 °C and restored above 1 °C).
- 3.4.13.6. Weekly fan runtime limit exceeded.

3.5. Unit Ventilators Sequence of Operations:

3.5.1. Discretionary Fire Alarm Shutdown Mode:

The supply fan is off, and associated exhaust fan is off (where applicable), the outdoor air mixing dampers are in the 0 % outdoor air position, the hydronic heating remains in its current state and the cooling is off (where applicable).

The face and bypass damper are open to the face of the coil(s).

The associated relief dampers (where applicable) are in the closed position.

This is not intended to replace the hard-wired fan shutdown provided by others when required by Code. Normal UV unit functions are auto restored on relay signal from the fire alarm panel reset.

3.5.2. Software Freezestat Shutdown Mode:

The duct/unit mounted supply air temperature sensor acts as a software freezestat (triggered below 1 °C after 3 minutes, restored above 5 °C after 3 minutes, and auto reset after 5 minute delay).

3.5.3. Unoccupied Mode

The system will be in Unoccupied Mode when not in Morning Warmup, Occupied or Standby modes. The system will cycle between Idle State, Heating State and Pushbutton Override States to meet the demands from each state and return to the Idle State when the demands are satisfied.

3.5.3.1. (Idle State)

Mode is active usually between 11:00 p.m. to 7:00 a.m. Monday to Friday and 24 hours Saturday and Sunday. The supply fan is off, associated exhaust fan is off (where applicable), the Global Ventilation Mode is off, the outdoor air mixing dampers are in the 0% outdoor air position, the heating is off and the cooling is off (where applicable). The face and damper is in the face position. The associated relief dampers (where applicable) are closed.

3.5.3.2. (Heating State)

System cycles on a call for unoccupied heating. The face and bypass dampers go to face position to obtain room temperature setpoint.

Heating temperature nominally 16.0 °C space temperature setpoint with an increased space temperature setpoint to 17.0 °C at -10.0 °C Outdoor Air Temperature or lower and 18.0 °C at -20.0 °C Outdoor Air Temperature or lower (each adjustable).

Mechanical Cooling: Disabled (where applicable)

Free Cooling: Disabled

Global Ventilation Schedule: Disabled

3.5.3.3. (Push Button Override State)

If the override pushbutton is pressed, at any room sensor, the associated system will switch to the Occupied Mode for 2 hours (adjustable). With outdoor air ventilation and cooling enabled.

3.5.4. Morning Warmup Mode:

An optimized start routine for heating advances the system start time when morning warm-up is required. An optimized start, based on the time of day schedule, outdoor air temperature and the room temperature is provided for heating. The global ventilation schedule is off.

The supply fan is on, the associated exhaust fan is off (where applicable), the outdoor air mixing dampers are in the 0 % outdoor air position, the heating at full capacity is on and the cooling is off (where applicable).

The heat pump (where applicable) is the first stage of heat but when it is in defrost mode or when the outdoor air is too cold, then hydronic heat is used to provide heat.

The face and bypass damper(s) start in the face position. The associated exhaust dampers (where applicable) start in the closed position.

The optimized start program is to begin up to 105 minutes before the occupancy schedule to allow for morning warm up to bring the lowest zone temperature up to occupancy setpoint.

3.5.5. Occupied Mode

Time of day schedule, which starts the unit along with an Optimum Start program usually between 7:00 a.m. and 4:00 p.m. Monday to Friday, when not overridden by a Holiday Schedule, Standby Occupancy Mode or Unoccupied Mode.

The Global Ventilation Schedule is on.

Fan status indication is from the current sensing device(s).

Fan operation: The supply fan and return fan (where applicable) run continuously.

Heating temperature nominal: 21.5 °C +/- 1.0 °C (adjustable)

Mechanical cooling temperature nominal 24.5 °C +/- 1.0 °C (adjustable)

Free cooling enabled temperature nominal 22.5 °C +/-1.0 °C

Global Ventilation Schedule: Enabled

3.5.6. Standby Occupancy Mode:

Time of day schedule starts the unit(s) usually between 4:00 p.m. and 11:00 p.m. Monday to Friday.

Minimum Outdoor Air is set to zero when the Global Ventilation Schedule is off.

Fan operation: Supply fan and associated exhaust fan (where applicable) runs only on a call from heating or cooling only.

Ventilation normally set to zero (with a future provision to adjust).

Heating temperature setpoint nominal: 21.5 °C +/- 1.0 °C (adjustable)

Mechanical Cooling temperature setpoint nominal 24.5 °C +/- 1.0 °C (adjustable) (where applicable)

Free Cooling: Disabled

Global Ventilation Schedule: Disabled

3.5.7. Ventilation Lockout (Sequence):

When the ventilation lockout switch, usually located in the Custodial Office, is engaged, all outdoor air dampers close, free cooling is disabled, and the system switches to Standby Occupancy Mode of operation.

3.5.8. Heating:

3.5.8.1. Outdoor Air Temperature used to determine Heating Enable Mode:

A set of thresholds that are user adjustable at a global (board wide) or local (site specific) level, triggers the heating enable mode based on the outdoor air temperature below the threshold. The threshold is further adjusted by a calendar schedule.

Typical default values are: 16 °C from September to May and 5 °C from June to August.

3.5.8.2. Default Setpoint:

When the Heating Mode is active, the default room temperature setpoint remains unchanged.

3.5.8.3. Call for Heating:

The room temperature sensor modulates the face & bypass damper with heat pump or hydronic heating to maintain the temperature setpoint.

The heat pump is the first stage of heat (nominally to 5 °C outdoor air temperature) but when it is in defrost mode or when the outdoor air is too cold, then hydronic heat is used to provide heat.

When in heating mode, the mixing dampers are in minimum position and cooling is off.

Mechanical heating is used until the heating calls (from room controller PID or Unoccupied Heating thresholds) are satisfied.

The room temperature sensor regulates heating output to maintain the occupied heating setpoint. Local setpoint adjustment is provided.

Where there is a zone served by radiation, the radiation valve opens (where applicable) as the first stage of heating.

Hydronic

For Heating Valve, (where applicable) 0 % signal (10 Volts) closes the heating valve. A 100% signal (below 2 Volts) opens the heating valve.

3.5.9. Cooling Sequence:

3.5.9.1. Outdoor Air Temperature used to determine cooling enable mode:

A set of thresholds that are user adjustable at a global (board wide) or local (site specific) level, triggers the cooling enable mode based on the Outdoor Air Temperature exceeding the threshold. The threshold is further adjusted by a calendar schedule. Typical default values are: 18 °C from September to May and 21 °C from June to August.

3.5.9.2. Default Setpoint:

When the cooling enable mode is active, the default room temperature setpoint is raised by 2 °C.

3.5.9.3. Call for Cooling:

When free cooling is available, and a demand for cooling is in place, free cooling will be used first, and if the demand for cooling is still in place, mechanical cooling will be used until the cooling calls (from room controller PID) are satisfied.

The room temperature sensor also modulates the mixing dampers (for free cooling) to maintain the occupied free cooling setpoint

Heating temperature setpoint nominal: 21.5 °C +/- 1.0 °C (adjustable)

The heat pump is the first stage of heat but when it is in defrost mode or when the outdoor air is too cold, then hydronic heat is used to provide heat.

Cooling setpoint is maintained at 3 °C higher than the default room setpoint and will not go below 23.5 °C.

Mechanical Cooling temperature setpoint nominal 24.5 °C +/- 1.0 °C (adjustable)

The room temperature sensor modulates the mixing dampers in sequence with DX cooling (where applicable) and face and bypass dampers in face position, to maintain the cooling temperature setpoint.

When mechanical cooling is on, heating is off.

- 3.5.10. Economizer Operation (and CO2 Demand Control Ventilation) :
- 3.5.10.1. During Occupied Mode, economizer operation will be substituted for first stage mechanical cooling when the outdoor air temperature and relative humidity are below the Free Cooling Setpoint Sequence of Operation. If the outdoor air temperature is below this Free Cooling Setpoint the mixing dampers will be modulated open on a call for cooling to provide 'free' cooling.
- 3.5.10.2. Minimum outdoor air damper position signal may exceed the economizer signal. A typical value for minimum outdoor air damper position is 5 % outdoor air, (0 % when an associated stand alone ERV is present) which can vary based on use case of the occupied space based on ASHRAE 62.1 net occupiable floor area outdoor air rate.
- 3.5.10.3. For units with an associated exhaust, the exhaust fan runs when the outdoor air damper is more than 50 % open.
- 3.5.10.4. During morning warm-up, the outdoor air minimum position is set to zero.
- 3.5.10.5. During Unoccupied Mode and Standby Occupancy Mode, free cooling is unavailable.
- 3.5.10.6. During Occupied Mode, If the outdoor air temperature and relative humidity are above the Free Cooling Setpoint Sequence of Operation, the mixing dampers will be set to the minimum outdoor air threshold unless otherwise required under ASHRAE 62.1 Ventilation Rate Procedure - net occupiable floor area outdoor air rate (w/ CO₂ demand controlled ventilation reset).
- 3.5.10.7. Each return air duct-mounted or space mounted CO₂ sensor acts as a high limit and will increase the amount of minimum outdoor air, to a maximum of 40 % outdoor air as the CO₂ level increases from 1100 ppm (1000 ppm to 1200 ppm over a ramped 15 minute period).

- 3.5.11. Limits and Safeties
- 3.5.11.1. If the outside air temperature exceeds the Global Free Cooling Setpoint, the mixing dampers return to the minimum position.
- 3.5.11.2. Mixed air damper minimum position control is provided when the Global Ventilation Schedule is on (initially 10 %OA).
- 3.5.11.3. The exhaust air damper (if applicable) opens from 0 to 100 % as the outdoor air damper opens from minimum position to maximum position.
- 3.5.11.4. The minimum outdoor damper position is ramped from minimum to 40 % as the room sensor CO₂ increased from 1000 ppm to 1200 ppm over a 15 minute period.
- 3.5.11.5. The fan must be running before the mixing dampers, face and bypass dampers, heat pump (if applicable) and DX cooling will operate.
- 3.5.11.6. The economizer is limited to 60 % because of the intake louver dimensions. (if applicable)
- 3.5.11.7. The supply air sensor acts as a low limit to ensure temperature does not fall below setpoint (initially 16 °C, reset to 13 °C on a call for free cooling).
- 3.5.11.8. A software freezestat on the supply air temperature shuts the fan down and closes the outdoor air damper when the supply air temperature is below 3 °C for 30 seconds (resets above 6 °C with 5 minute delay before restart).
- 3.5.11.9. If the hard-wired freezestat trips, the fan shuts down, the heat pump shuts down (if applicable), the outside air damper closes, the heating valve opens and an alarm is generated at the BAS.
- 3.5.11.10. DX cooling is disabled when the outside air temperature falls below the global mechanical cooling disable setpoint (initially 14 °C).(where applicable)
- 3.5.11.11. DX cooling has a minimum off time of 5 minutes.(where applicable)
- 3.5.11.12. DX cooling has a supply air temperature low limit (disabled below 6 °C and enabled above 12 °C). (where applicable)
- 3.5.11.13. The face & bypass damper is in the face position and the heating valve is closed when DX cooling is operating, (where applicable)
- 3.5.11.14. The heat pump is disabled when the outdoor air temperature is below 5 °C and hydronic heat is used (where applicable)
- 3.5.11.15. Defrost mode is determined by a sudden drop in supply air temperature while the heat pump is heating.
- 3.5.11.16. 16) Heating is disabled when the outside air temperature is above the global heating disable setpoint (typically 16 °C).
- 3.5.11.17. 17) The heating valve min. position increases from 0 to 60% as the outside air temperature falls from 3 °C to -3 °C to reduce the likelihood of coil freeze.

- 3.5.12. Alarms
- An alarm will be generated upon any of the following conditions:
- 3.5.12.1. Fan status does not match the fan start/stop signal.
- 3.5.12.2. Room temperature is too high (triggered above 36 °C and restored below 34 °C) or too low (triggered below 14 °C and restored above 15 °C).
- 3.5.12.3. Supply air temperature too high (triggered above 65 °C and restored below 60 °C) or too low (triggered below 8 °C and restored above 10 °C).
- 3.5.12.4. Software or hard-wired freezestat tripped.
- 3.5.12.5. Fan runtime exceeded weekly runtime setpoint.
- 3.5.12.6. CO₂ level too high (triggered above 1700 ppm and restored below 1650 ppm) or too low (triggered below 250 ppm and restored above 300 ppm).
- 3.5.12.7. Heat pump defrost mode is on more than 40 % of the time.

3.6. Air Handlers Sequence of Operations:

3.6.1. Discretionary Fire Alarm Shutdown Mode:

The supply fan is off, the return fan is off (where applicable) and power exhaust fan is off (where applicable), the outdoor air mixing dampers are in the 0 % outdoor air position, heating is disabled and cooling is disabled. This is not intended to replace the hard-wired fan shutdown provided by others when required by Code. Normal AHU functions are auto restored on relay signal from the fire alarm panel reset.

3.6.2. Freeze-stat Shutdown Mode(s):

3.6.2.1. Software

The duct/unit mounted supply air temperature sensor acts as a software freeze-stat (triggered below 1 °C after 3 minutes, restored above 5 °C after 3 minutes, and auto reset after 5 minute delay).

3.6.2.2. Hard-Wired

BAS monitors the status of the duct mounted hard wired freeze-stat (provided by others, where applicable) that shuts down the AHU fan(s) and spring closes the outside air damper(s) if the air temperature leaving the heating coil falls below the freeze-stat setpoint.

3.6.3. Unoccupied Mode:

Mode is active usually between 11:00 p.m. to 7:00 a.m. Monday to Friday and 24 hours Saturday and Sunday.

The system will be in Unoccupied Mode when not in Morning Warmup, Occupied or Standby modes.

The system will cycle between Idle State, Heating State or Pushbutton Override States to meet the demands from each state and return to the Idle State when the demands from each state are satisfied.

3.6.3.1. (Idle State)

The supply fan is off, associated return fan is off (where applicable), the Global Ventilation Mode is disabled, the outdoor air mixing dampers are in the 0 % outdoor air position, the gas heating is disabled (where applicable) and the cooling is disabled (where applicable).

For hydronic heated AHU, when outdoor air temperature is below 3 °C, the heating valve (where applicable) modulates to maintain a supply air plenum temperature of 15 °C. When outdoor air temperature is 3 °C or above, the heating valve (where applicable) is closed to the coil. The heating coil circulating pump (where applicable) runs continuously in Winter Mode.

3.6.3.2. (Heating State)

System cycles on a call for unoccupied heating. A full call for (all stages or full heat modulation where applicable) heating until setpoint is reached.

Heating temperature nominally 16.0 °C space temperature setpoint with an increased space temperature setpoint to 17.0 °C at -10.0 °C OAT or lower and 18.0 °C at -20.0 °C OAT or lower (each adjustable)

Free Cooling: Disabled

Global Ventilation Schedule: Disabled

3.6.3.3. Push Button Override State)

If the override pushbutton is pressed, at any associated room sensor, the associated system will switch to the Occupied Mode for 2 hours (adjustable). With outdoor air ventilation enabled.

3.6.4. Morning Warmup Mode:

An optimized start, based on the time of day schedule, outdoor air temperature and the indoor zone temperature is provided for heating.

The global Global Ventilation Schedule is disabled. The supply fan is on, the return fan is on (where applicable), the outdoor air mixing dampers are in the 0 % outdoor air position and heating is enabled at full capacity.

The optimized start program is to begin up to 105 minutes (adjustable) before the occupancy schedule to allow for morning warm up to bring the lowest space temperature up to occupancy setpoint.

3.6.5. Occupied Mode:

Time of day schedule, which starts the unit along with an Optimum Start program usually between 7:00 a.m. and 4:00 p.m. Monday to Friday, when not overridden by a Holiday Schedule, Standby Occupancy Mode or Unoccupied Mode.

Global Ventilation Schedule is enabled.

Air handler fan status confirmed by current sensing device(s) or VFD feedback.

Fan operation: The supply fan and return fan (where applicable) run continuously.

Room heating temperature nominal: 21.5 °C +/- 1.0 °C (adjustable)

For modulating burners, (where applicable) 0 % signal (0 Volts) heating discharge temperature setpoint is at minimum discharge temperature (typically set on the HV unit to 17 °C). A 100 % signal (10 Volts) heating discharge temperature setpoint is at maximum discharge temperature setpoint (typically set on the HV unit to 35 °C).

Room Free Cooling Enabled temperature setpoint nominal 22.5 °C +/-1.0 °C

Room Mechanical Cooling temperature setpoint nominal 24.5 °C +/- 1.0 °C (adjustable)

3.6.6. Standby Occupancy Mode:

Time of day schedule starts the unit(s) usually between 4:00 p.m. and 11:00 p.m. Monday to Friday. Minimum Outdoor Air is set to zero when the Global Ventilation Schedule is off. Supply fan and return fan (where applicable) runs only on a call from heating. Ventilation normally set to zero (with a future provision to adjust).
Room heating temperature nominal: 21.5 °C +/- 1.0°C
Room Free Cooling: Disabled
Mechanical Cooling: Enabled
Global Ventilation Schedule: Disabled

3.6.7. Ventilation Lockout (Sequence):

When the ventilation lockout switch, usually located in the Custodial Office, is engaged, all outdoor air dampers close, free cooling is disabled, and the system switches to Standby Occupancy Mode of operation.

3.6.8. Heating Sequence:

3.6.8.1. Outdoor Air Temperature used to determine Heating Enabled Mode:

A set of thresholds that are user adjustable at a Global (board wide) or Local (site specific) level, triggers the heating enable mode based on the outdoor air temperature below the threshold. The threshold is further adjusted by a calendar schedule. Typical default values are: 16 °C from September to May and 5 °C from June to August.

3.6.8.2. Default Setpoint:

When the Heating Mode is active, the default room temperature setpoint remains unchanged.

3.6.8.3. Call for Heating:

Heating is used until the heating calls (from room controller PID or unoccupied heating thresholds) are satisfied. For modulating burners, (where applicable) 0 % signal (0 Volts) heating discharge temperature setpoint is at minimum discharge temperature (typically set on the unit to 17 °C). A 100 % signal (10 Volts) heating discharge temperature setpoint is at maximum discharge temperature setpoint (typically set on the unit to 35 °C). For hydronic heated AHUs, (where applicable) 0 % signal (10 Volts) closes the heating valve. A 100% signal (2 Volts) opens the heating valve. (Note: The heating valve is reverse acting to the controller output signal and is to fail safe open) The heating coil circulating pump (where applicable) runs continuously in Winter Mode. The room temperature sensor with the lowest temperature regulates heating output to maintain the occupied heating setpoint. Local setpoint adjustment is provided. The power exhaust fan or relief fan (if applicable) cycles based on the rooftop economizer position. Where there is a zone served by radiation, the radiation valve opens (where applicable) as the first stage of heating.

3.6.9. Mechanical Cooling Sequence:

3.6.9.1. Default Setpoint:

When the Mechanical Cooling Mode is active, the default room temperature cooling setpoint is 24.5 °C +/- 1°C and will not go below 23.5 °C.

3.6.9.2. Call for Cooling:

Mechanical cooling will be used until the cooling calls (from room controller PID) are satisfied.

3.6.9.3. Chilled Water Cooling

For units with Cooling Valves serving chilled water coil(s), (where applicable) 0 % signal (2 Volts) closes the cooling valve. A 100% signal (10 Volts) opens the cooling valve. (Note: The cooling valve is direct acting to the controller output signal and is to fail safe closed)

3.6.10. Free Cooling Sequence:

3.6.10.1. Outdoor Air Temperature used to determine cooling enable mode:

(Free cooling enabled) A set of thresholds that are user adjustable at a global (board wide) or local (site specific) level, triggers the cooling enable mode based on the outdoor air temperature exceeding the threshold. The threshold is further adjusted by a calendar schedule. Typical default values are: 18 °C from September to May and 21 °C from June to August.

3.6.10.2. Default Setpoint:

When the cooling enable mode is active, the default room temperature setpoint is raised by 2 °C higher than the heating setpoint and will not go below 23.5 °C

3.6.10.3. Call for Cooling:

When free cooling is available, and a demand for cooling is in place, free cooling will be used, until the cooling calls (from room controller PID) are satisfied. The room temperature sensor also modulates the mixing dampers (for free cooling) to maintain the occupied free cooling setpoint.

- 3.6.11. Economizer Operation (and CO₂ Demand Control Ventilation):
 During Occupied Mode, economizer operation will be substituted for first stage mechanical cooling when the outdoor air temperature and relative humidity are below the Free Cooling Setpoint Sequence of Operation. If the outdoor air temperature is below this free cooling setpoint the mixing dampers will be modulated open on a call for cooling to provide 'free' cooling.
- 3.6.11.1. Minimum Outdoor Air Damper Position
 A typical value for minimum outdoor air damper position is 5 % outdoor air, (0 % when an associated stand alone ERV is present) which can vary based on use case of the occupied space based on ASHRAE 62.1 net occupiable floor area outdoor air rate. Minimum outdoor air damper position signal may exceed the economizer signal.
- 3.6.11.2. Economizer Operation
 The outdoor air mixing dampers will be set to the minimum outdoor air position unless otherwise required under ASHRAE 62.1 Ventilation Rate Procedure - net occupiable floor area outdoor air rate (w/ CO₂ demand controlled ventilation reset).
 If Free Cooling is enabled during Occupied Mode, economizer operation will be substituted for first stage mechanical cooling, the mixing dampers will be modulated open on a call for cooling to provide 'free' cooling.
 For air handling units with power exhaust (where applicable), the exhaust fan runs when the outdoor air damper is more than 50 % open
 During morning warm-up, the outdoor air minimum position is set to zero.
 During Unoccupied Mode and Standby Occupancy Mode, free cooling is unavailable.
 Each return air duct-mounted or space mounted CO₂ sensor acts as a high limit and will increase the amount of minimum outdoor air, to a maximum of 40 % outdoor air as the CO₂ level increases from 1000 ppm to 1200 ppm over a ramped 15 minute period). CO₂ levels are automatically logged at 10 minute intervals
 Each return air duct-mounted or space mounted CO₂ sensor acts as a high limit and will increase the amount of minimum outdoor air, to a maximum of 40 % outdoor air as the CO₂ level increases from 1000 ppm to 1200 ppm over a ramped 15 minute period). CO₂ levels are automatically logged at 10 minute intervals
- 3.6.12. Additional Rooms Partition Switch
 Any additional room(s) (i.e. Music Rooms) that are separated by a partition wall from a space where cooling is not allowed, will disable mechanical cooling for the associated units that serve the additional room(s). If the Music Room wall is open to the Gym, mechanical cooling serving the Music Room is disabled. Partition switch and lamacoid label to be provided above Music Room Sensor by the Building Automation Contractor. Label to read "No Cooling when Partition is Open to Gym".
- 3.6.13. Limits and Safeties
- 3.6.13.1. The maximum outdoor air damper position is limited based on the outdoor air temperature to prevent excessively low supply air temperature during startup. At -20 °C outdoor air temperature, and below, the maximum outdoor air damper position will be 0 % open and at 10 °C outdoor air temperature the maximum outdoor air damper position will be 100 %.
- 3.6.13.2. The mixed air temperature sensor acts as a low limit to ensure temperature does not fall below setpoint (typically 11 °C). In applications where the mixed air sensor is located after the DX cooling coil, the setpoint is reduced (to typically 5 °C) when DX cooling is enabled.
- 3.6.13.3. The supply air temperature sensor acts as a high limit for each stage of heating (stage 1 heating disabled above 60 °C and enabled below 50 °C, stage 2 heating disabled above 55 °C and enabled below 45 °C) and a low limit for each stage of cooling (stage 1 disabled below 5 °C and enabled above 13 °C, stage 2 disabled below 8 °C and enabled above 18 °C).
- 3.6.13.4. The supply air temperature sensor acts as a software freeze-stat (triggered below 1 °C for 1 minute and restored above 5 °C after a 5 minute delay).
- 3.6.13.5. The supply fan has a delay-off time of 90 seconds.
- 3.6.13.6. The DX cooling has a minimum-off time of 5 minutes.
- 3.6.13.7. DX cooling is disabled when the outdoor air temperature is below global DX disable setpoint (typically 18 °C) or when fan is off.
- 3.6.13.8. Gas heating is disabled when the outdoor air temperature is above the global heating disable setpoint (typically 14 °C) or when the fan is off.
- 3.6.13.9. Stage 1 gas heating (where applicable for units with multiple stages of heating) has a minimum run time of 3 minutes.
- 3.6.13.10. Minimum outdoor air is provided when enabled by the global minimum outdoor air time schedule. The minimum outdoor air is adjustable from the graphic and is typically a default of 10 % open outdoor damper position.
- 3.6.13.11. The return air carbon dioxide sensor acts as a high limit to increase the amount of minimum outdoor air from 0 % to 40 % as the reading increases from 1000 ppm to 1200 ppm (1000 ppm to 1200 ppm over a ramped 15 minute period).
- 3.6.13.12. Cooling cannot turn on until heating has been off for a minimum of 5 minutes.
- 3.6.13.13. During Occupied Mode, and the outdoor air temperature is above -1 °C, heating stage 2 (where applicable) has a delay-on time of 15 minutes, except when the outdoor air temperature is below -3 °C with a +2 °C deadband.
- 3.6.13.14. The default room temperature cooling setpoint is 2 °C above the heating setpoint when mechanical cooling is enabled. The standard mechanical cooling room setpoint will be limited to a minimum of 23.5 °C.
- 3.6.13.15. When the ventilation lockout switch (usually located at the custodial office) is engaged, the outdoor air dampers close, free cooling is disabled, and the system switches to standby mode of operation.
- 3.6.13.16. Minimum outdoor air is set to zero when the global ventilation schedule is off.
- 3.6.13.17. Supply and Return Fan(s) disabled if the hydronic heating coil pump status is not running when required.

- 3.6.13.18. Discretionary Fire Alarm Shutdown Mode to be enabled on the fire alarm status.
- 3.6.13.19. The heating coil pump (for hydronic units where applicable) turns off when the outside air temperature exceeds the heating disable setpoint (60 second delay-off time)

3.6.14. **Alarms:**

An alarm will be generated upon the following conditions:

- 3.6.14.1. Supply and and or Return Fan status does not match the start/stop signal.
- 3.6.14.2. Mixed air temperature too high alarm (triggered above 50 °C and restored below 48 °C) or too low alarm (triggered below 5 °C and restored above 7 °C). Low mixed air temperature alarm set to lower thresholds when Mixed Air Temperature sensor is installed after the DX or cooling coil.
- 3.6.14.3. Supply air temperature too high alarm (triggered above 65 °C and restored below 63 °C) or too low alarm (triggered below 5 °C and restored above 7 °C)
- 3.6.14.4. Space temperature too high alarm (triggered above 42 °C and restored below 40 °C) for non-cooling systems, (triggered above 38 °C and restored below 36 °C) for cooling systems.
- 3.6.14.5. Space temperature too low alarm (triggered below 14 °C and restored above 16 °C).
- 3.6.14.6. Weekly fan runtime limit exceeded.
- 3.6.14.7. Return air carbon dioxide too high alarm (triggered above 1700 ppm and restored below 1650 ppm) or too low alarm (triggered below 250 ppm and restored above 300 ppm) with a 15 minute delay.
- 3.6.14.8. Software freezestat tripped.
- 3.6.14.9. Low mixed air temperature alarm (triggered below 5 °C and restored above 7 °C).
- 3.6.14.10. Low return air carbon dioxide alarm (triggered below 250 ppm and restored above 275 ppm) or high return air CO2 alarm (triggered above 1200 ppm and restored below 1100 ppm).
- 3.6.14.11. High supply air static pressure alarm (triggered 30 % above setpoint and restored below 10 % above setpoint) or low supply air static pressure alarm (triggered 30 % below setpoint and restored above 10% below setpoint).
- 3.6.14.12. High supply air temperature alarm (triggered above 40 °C and restored below 38°C) or low supply air temperature alarm (triggered below 8 °C and restored above 10°C).
- 3.6.14.13. Low return air temperature alarm (triggered below 14 °C and restored above 15°C) or high return air temperature alarm (triggered above 40 °C and restored below 38 °C).
- 3.6.14.14. Freezestat or differential pressure limit switch tripped.
- 3.6.14.15. Hydronic heating coil pump status in wrong mode
- 3.6.14.16. Software freezestat tripped.

3.7. VAV AHU HVAC Fan System Sequence of Operations:

3.7.1. **Discretionary Fire Alarm Shutdown Mode:**

The supply fan is off, the return fan is off (where applicable) and power exhaust fan is off (where applicable), the outdoor air mixing dampers are in the 0 % outdoor air position, heating is disabled and cooling is disabled. This is not intended to replace the hard-wired fan shutdown provided by others when required by Code. Normal AHU HVAC unit functions are auto restored on relay signal from the fire alarm panel reset.

3.7.2. **Freezestat Shutdown Modes:**

3.7.2.1. **Software**

The duct/unit mounted supply air temperature sensor acts as a software freezestat (triggered below 1 °C after 30 seconds, restored above 5 °C after 5 minutes).

3.7.2.2. **Hard-Wired**

BAS monitors the status of the duct mounted hard wired freeze-stat (provided by others, where applicable) that shuts down the AHU fan(s) and spring closes the outside air damper(s) if the air temperature leaving the heating coil falls below the freeze-stat setpoint.

3.7.3. **Unoccupied Mode:**

Mode is active usually between 11:00 p.m. to 7:00 a.m. Monday to Friday and 24 hours Saturday and Sunday.

The system will be in Unoccupied Mode when not in Morning Warmup, Occupied or Standby modes. The system will cycle between Idle State, Heating State and Pushbutton Override State to meet the demands from each state and return to the Idle State when the demands of each state are satisfied.

3.7.3.1. **(Idle State)**

The supply fan is off, the return fan is off (where applicable) power exhaust fan is off (where applicable), the Global Ventilation Schedule is disabled, the outdoor air mixing dampers are in the 0% outdoor air position, and cooling is disabled. The heating valve modulates to maintain a plenum temperature of 15°C when the outside air temperature is below 1 °C and closes when outside air temperature is above 3 °C. The heating coil circulating pump (where applicable) runs continuously when Heating Mode is enabled.

3.7.3.2. **(Heating State)**

System cycles on a call for unoccupied heating. A full call for (all stages or full heat modulation where applicable) heating until setpoint is reached.

Heating temperature nominally 16.0 °C space temperature setpoint with an increased space temperature setpoint to 17.0 °C at -10.0 °C OAT or lower and 18.0 °C at -20.0 °C OAT or lower (each adjustable)
The VAV HVAC unit supply air static pressure setpoint is increased by 20 %. VFD(s) modulate to maintain static pressure setpoint.
Mechanical Cooling: Disabled
Free Cooling: Disabled

3.7.3.3. (Push Button Override State)

If the override pushbutton is pressed, at any associated room sensor, the associated system will switch to the Occupied Mode for 2 hours (adjustable). With outdoor air ventilation enabled.
Mechanical Cooling: Enabled (per Cooling Enable Mode)
Free Cooling: Disabled
Global Ventilation Schedule: Enabled (only at the associated unit)

3.7.4. Morning Warmup Mode:

An optimized start, based on the time of day schedule, outdoor air temperature and the lowest indoor zone temperature is provided for heating.
The Global Ventilation Schedule is disabled.
The supply fan is on, the return fan is on (where applicable), the outdoor air mixing dampers are in the 0 % outdoor air position, heating is enabled at full capacity and cooling is disabled.
The VAV VFD drive(s) starts in the minimum position.
The VAV boxes zone dampers start in the 100 % open position.
The Optimized Start Program is to begin up to 105 minutes before the occupancy schedule to allow for morning warm up to bring the lowest zone temperature up to the occupancy setpoint.
Free Cooling: Disabled
Mechanical Cooling: Disabled
Global Ventilation Schedule: Disabled (outdoor dampers are closed)

3.7.5. Occupied Mode:

Time of day schedule, which starts the HVAC unit(s) along with an Optimum Start program usually between 7:00 a.m. and 4:00 p.m. Monday to Friday, when not overridden by a Holiday Schedule, Standby Occupancy Mode or Unoccupied Mode.
Global Ventilation Schedule: Enabled
AHU HVAC unit fan status confirmed by current sensing device(s) or VFD feedback.
Fan operation: The supply fan and return fan (where applicable) run continuously.
Room Heating Temperature Setpoint nominal: 21.5 °C +/- 1.0 °C (adjustable)
Room Free Cooling Enabled Temperature Setpoint nominal 22.5 °C +/-1.0°C
Room mechanical cooling temperature setpoint nominal 24.5 °C +/- 1.0°C (adjustable)
Supply and return fans run continuously.
Supply air temperature sensor operates the heating valve (or stages of gas heating or modulating gas heating where applicable), the mixing dampers (for free cooling) and the chilled water valve (or stages of DX cooling where applicable) in sequence to maintain the Supply Air Temperature Setpoint
Supply air static pressure sensor controls the supply VFD fan speed to maintain the Supply Air Static Setpoint

3.7.6. Standby Occupancy Mode:

Time of day schedule controls the AHU HVAC unit(s) usually between 4:00 p.m. and 11:00 p.m. Monday to Friday. (Between Occupied and Unoccupied Modes.)
Minimum outdoor air is set to zero when the global ventilation schedule is off.
Fan operation: Supply fan and return fan (where applicable) runs only on a call from heating or cooling only.
Ventilation normally set to zero (with a future provision to adjust).
Room heating temperature setpoint nominal: 21.5 °C +/- 1.0 °C (adjustable)
Room Mechanical Cooling temperature setpoint nominal 24.5 °C +/- 1.0°C (adjustable)
Free Cooling: Disabled
Mechanical Cooling: Enabled (Enabled when within the applicable limits and safeties)

3.7.7. Ventilation Lockout (Sequence):

When the ventilation lockout switch, usually located in the Custodial Office, is engaged, all outdoor air dampers close, free cooling is disabled, and the system switches to Standby Occupancy Mode of operation.
When the ventilation lockout switch is disengaged, systems return to mode of operation based on the time of day schedule.

3.7.8. Supply Air Temperature Setpoint:

The Supply Air Temperature Setpoint is reset between 13 °C to 16 °C as the outside air temperature falls from 22 °C to 10 °C.
The Supply Air Temperature Setpoint is also reset +/-5 °C based on the VAV box requiring the most cooling (based on the maximum of all the Cooling PIDs of the VAV boxes (with 10 minute ramping) associated with the VAV fan system).

The Supply Air Temperature Setpoint is limited to a range of 12 °C to 20 °C.

3.7.9. Supply Air Static Pressure Setpoint:

The Supply Air Static Setpoint which is reset between 200 Pa and 300 Pa as the outside air temperature rises from –10 °C to 25°C.

3.7.10. Heating Sequence:

3.7.10.1. Default Setpoint:

When the Heating Mode is active, the Supply Air Temperature Setpoint remains unchanged.

3.7.10.2. Call for Heating:

Mechanical heating is used until the heating calls (from room controller PID, typically stage 1 heating is enabled at 25 %Clg PID signal and disabled at 50 %Clg PID signal and stage 2 heating is enabled at 5 %Clg PID signal and disabled at 25 %Clg PID signal or Night Setback thresholds) are satisfied.

Natural Gas

For Modulating Burners, (where applicable) 0 % signal (0 Volts) heating discharge temperature setpoint is at minimum discharge temperature (typically set on the rooftop unit to 17 °C). A 100% signal (10 Volts) heating discharge temperature setpoint is at maximum discharge temperature setpoint (typically set on the rooftop unit to 35 °C).

The room temperature sensor regulates heating output to maintain the occupied heating setpoint. Local setpoint adjustment is provided. The power exhaust fan or return fan (if applicable) cycles based on the rooftop economizer position.

Hydronic

For units with Heating Valves, (where applicable) 0 % signal (10 Volts) closes the heating valve. A 100% signal (below 2 Volts) opens the heating valve. (Note:The heating valve is reverse acting to the controller output signal and is to fail safe open)

The heating coil circulating pump (where applicable) runs continuously in winter.

Radiation Zone

Where there is a zone served by radiation, the radiation valve opens (where applicable) and is to be substituted as the first stage of heating.

3.7.11. Mechanical Cooling Sequence:

3.7.11.1. Default Setpoint:

When the Cooling Mode is active, the Supply Air Temperature Setpoint remains unchanged.

3.7.11.2. Call for Cooling:

When Free Cooling is available, and a demand for cooling is in place, free cooling will be used first, and if the demand for cooling is still in place, mechanical cooling will be used until the supply air temperature cooling calls (from supply air controller PID, typically stage 1 cooling is enabled at 65 %Clg PID signal and disabled at 60 %Clg PID signal and stage 2 cooling is enabled at 95 %Clg PID signal and disabled at 60 %Clg PID signal) are satisfied.

The supply air temperature sensor also modulates the mixing dampers (for free cooling) to maintain the occupied free cooling setpoint.

Chilled Water Cooling

For units with Cooling Valves, (where applicable) 0 % signal (0 Volts) closes the cooling valve. A 100% signal (10 Volts) opens the cooling valve. (Note:The cooling valve is direct-acting to the controller output signal and is to fail safe closed) .

3.7.12. Economizer Operation (Free Cooling) and Carbon Dioxide Demand Control Ventilation:

3.7.13. Default Room Temperature Setpoint

When the Free Cooling Mode is active, the Supply Air Temperature Setpoint remains unchanged.

3.7.13.1. Minimum Outdoor Air Damper Position

A typical value for minimum outdoor air damper position is 10 % outdoor air, (0 % when an associated stand alone ERV is present) which can vary based on use case of the occupied space based on ASHRAE 62.1 net occupiable floor area outdoor air rate.

Minimum outdoor air damper position signal may exceed the economizer signal.

3.7.13.2. Economizer Operation

The outdoor air mixing dampers will be set to the minimum outdoor air position unless otherwise required under ASHRAE 62.1 Ventilation Rate Procedure - net occupiable floor area outdoor air rate (w/ CO₂ demand controlled ventilation reset).

If Free Cooling is enabled during Occupied Mode, economizer operation will be substituted for first stage mechanical cooling, the mixing dampers will be modulated open on a call for cooling to provide 'free' cooling.

For air handling units with power exhaust (where applicable), the exhaust fan runs when the outdoor air damper is more than 50 % open

3.7.13.3. During morning warm-up, the outdoor air minimum position is set to zero.

3.7.13.4. During Unoccupied Mode and Standby Occupancy Mode, free cooling is unavailable.

3.7.13.5. Each return air duct-mounted or space mounted CO₂ sensor acts as a high limit and will increase the amount of minimum outdoor air, to a maximum of 40 % outdoor air as the CO₂ level increases from 1000 ppm to 1200 ppm over a ramped 15 minute period).

CO₂ levels are automatically logged at 10 minute intervals

3.7.13.6. Additional Rooms Partition Switch

Any additional room(s) (ie. Music Rooms) that are separated by a partition wall, will disable mechanical cooling (where applicable) for the associated units that serve the additional room(s). If the Music Room wall is open to the Gym, mechanical cooling serving the Music Room is disabled. Partition switch and lamacoid label to be provided above Music Room Sensor by the Building Automation Contractor. Label to read "No Cooling when Partition is Open to Gym".

3.7.14. Limits and Safeties

- 3.7.14.1. The maximum outdoor air damper position is limited based on the outdoor air temperature to prevent excessively low supply air temperature during startup. At -20 °C outdoor air temperature, and below, the maximum outdoor air damper position will be 0% open and at 10 °C outdoor air temperature the maximum outdoor air damper position will be 100 %.
- 3.7.14.2. The maximum outdoor air damper position is limited based on the outdoor air temperature to prevent excessively high supply air temperature. At 30 °C outdoor air temperature and above, the maximum outdoor air damper position will be 0% open and at 10°C outdoor air temperature, the maximum outdoor air damper position will be 100%
- 3.7.14.3. The mixed air temperature sensor acts as a low limit to ensure temperature does not fall below setpoint (typically 11 °C). In applications where the mixed air sensor is located after the DX cooling coil, the setpoint is reduced (to typically 5 °C) when DX cooling is enabled
- 3.7.14.4. The duct mounted supply air temperature sensor acts as a high limit for each stage of heating (for stage 1: disable above 60 °C, and enable below 50 °C, for stage 2:disable above 55 °C and enable below 45 °C) and a low limit for each stage of cooling (for stage 1: disable DX1 below 5 °C and enable DX1 above 10 °C, for stage 2: below 8 °C disable DX2 and above 13 °C enable DX2).
- 3.7.14.5. The duct/unit mounted supply air temperature sensor acts as a software freeze-stat (triggered below 1°C after 30 seconds, restored above 5 °C after 5 minutes).
- 3.7.14.6. The supply fan has a delay-off time of 90 seconds.
- 3.7.14.7. The DX cooling has a minimum-off time of 5 minutes.
- 3.7.14.8. DX cooling is disabled when the outdoor air temperature is below global DX disable setpoint (typically 2 °C below Cooling Enable setpoint) or when fan is off.
- 3.7.14.9. Gas heating is disabled when the outdoor air temperature is above the global heating disable setpoint (typically 2 °C above Heating Enable setpoint) or when the fan is off.
- 3.7.14.10. Stage 1 gas heating (where applicable for units with multiple stages of heating) has a minimum run time of 3 minutes.
- 3.7.14.11. The default zone setpoint is increased by 3°C when mechanical cooling is enabled (providing heating is disabled). The standard mechanical cooling setpoint will be limited to a (minimum of 23.5 °C - adjustable).
- 3.7.14.12. When the ventilation lockout switch (usually located at the custodial office) is engaged, the outdoor air dampers close, free cooling is disabled, and the system switches to Standby Occupancy Mode.
- 3.7.14.13. Minimum outdoor air is provided when enabled by the Global Ventilation Schedule.
- 3.7.14.14. The return air carbon dioxide sensor acts as a high limit to increase the amount of minimum outdoor air from 0 to 40 % as the reading increases from 1000 ppm to 1200 ppm.
- 3.7.14.15. Cooling cannot turn on until heating has been off for a minimum of 5 minutes.
- 3.7.14.16. During Occupied Mode, and the outdoor air is above -1 °C, heating stage 2 (where applicable) has a delay-on time of 15 minutes, except when the outdoor air temperature is below -3 °C with a +2 °C deadband.
- 3.7.14.17. Minimum outdoor air is set to zero when the global ventilation schedule is off.
- 3.7.14.18. Mixed air low pressure switch shuts down the fans if the pressure falls below setpoint.
- 3.7.14.19. Supply air high pressure switch shuts down the fans if the pressure exceeds the setpoint.
- 3.7.14.20. A supply air static pressure high limit control is provided (initially set at 400 Pa).
- 3.7.14.21. Mixed air sensor acts as a low limit to prevent the mixed air temperature from falling below setpoint (initially 12 °C).
- 3.7.14.22. The heating coil pump turns off when the outside air temperature exceeds the heating disable setpoint (60 s delay-off time).
- 3.7.14.23. The fan drives will not exceed 60 % until the supply air static pressure exceeds 25 Pa (to ensure a smooth start-up).
- 3.7.14.24. As the %OA increases from 0 % to 15 % the return fan speed drops from 100 % to 90 % of the supply fan speed.
- 3.7.14.25. The outdoor air damper shuts if the hydronic heating coil pump status is not running when required.

3.7.15. Alarms:

An alarm will be generated upon the following conditions:

- 3.7.15.1. Fan status does not match the start/stop signal.
- 3.7.15.2. Mixed air temperature too high alarm (triggered above 50 °C and restored below 48 °C) or too low alarm (triggered below 5 °C and restored above 7 °C). Low mixed air temperature alarm set to lower thresholds when Mixed Air Temperature sensor is installed after the DX or cooling coil.
- 3.7.15.3. Supply air temperature too high alarm (triggered above 65 °C and restored below 63 °C) or too low alarm (triggered below 5 °C and restored above 7 °C)
- 3.7.15.4. Space temperature too high alarm (triggered above 42 °C and restored below 40 °C) for non-cooling systems, (triggered above 38 °C and restored above 36 °C) for cooling systems.
- 3.7.15.5. Space temperature too low alarm (triggered below 14 °C and restored above 16 °C).
- 3.7.15.6. Weekly fan runtime limit exceeded.

- 3.7.15.7. Return air carbon dioxide too high alarm (triggered above 1700 ppm and restored below 1650 ppm) or too low alarm (triggered below 250 ppm and restored above 300 ppm) with a 15 minute delay.
- 3.7.15.8. Software freeze/stop tripped.
- 3.7.15.9. High supply air static pressure alarm (triggered 30% above setpoint and restored 10% above setpoint) or low supply air static pressure alarm (triggered 30% below setpoint and restored 10% above setpoint).
- 3.7.15.10. Low return air temperature alarm (triggered below 14 °C and restored above 15 °C) or high return air temperature alarm (triggered above 40 °C and restored below 38 °C).
- 3.7.15.11. Freeze/stop or differential pressure limit switch tripped.
- 3.7.15.12. Hydronic heating pump status does not match the start/stop signal.

3.7.16. VAV Box Sequence of Operations:

Each VAV box mode of operation tracks with its associated VAV Fan System mode of operation. The duct supply air temperature is sent to each associated VAV box and is used by the VAV box along with the space temperature to determine air flow setting in each mode of operation. Each VAV box (unless otherwise noted) has a space temperature sensor with setpoint adjust and push button override. Each VAV box reports its cooling demand back to its associated VAV fan system to reset the supply air temperature setpoint.

3.7.16.1. Fan Powered VAV Box (with reheat coil / radiant panel)

The space temperature sensor modulates the VAV box (between minimum and maximum air flow settings) in sequence with the reheat coil and/or radiant panel (if applicable) to maintain setpoint. A velocity sensor controls the air flow between minimum and maximum settings. The minimum air flow setting is adjusted based on the need for reheat. The fan runs continuously during occupied periods and the reheat valve modulates. Fans start 5 minutes before the air handling unit starts. When the central system is off, the primary air damper is closed. When Unoccupied, the fan cycles as required (with the reheat valve open) to maintain the unoccupied setpoint. Science / Art Rooms - When the local fume hood is energized, the minimum air flow setting is increased to 50 %. When the local room exhaust fan is energized, the VAV box opens to 100 % flow.

3.7.16.2. Damper-Only (no reheat or fan-powered box)

The space temperature sensor modulates the VAV box (between the minimum and maximum air flow settings) to maintain airflow setpoint. A velocity sensor controls the air flow between minimum and maximum air flow settings. Science / Art Rooms - When the local fume hood is energized, the minimum air flow setting is increased to 50 %. When the local room exhaust fan is energized, the VAV box opens to 100 % flow.

3.7.16.3. Damper-Only (with reheat coil / radiation valve)

The space temperature sensor modulates the VAV box (between minimum and maximum air flow settings) in sequence with the reheat coil and/or radiant panel (if applicable) to maintain setpoint. A velocity sensor controls the air flow between minimum and maximum settings. The minimum air flow setting is adjusted based on the need for reheat. Science / Art Rooms - When the local fume hood is energized, the minimum air flow setting is increased to 50 %. When the local room exhaust fan is energized, the VAV box opens to 100 % flow.

3.7.16.4. Fan Powered VAV Bypass / Dump Box (with reheat coil / radiant panel)

The space temperature sensor modulates the VAV box (air flow intake settings) in sequence with the reheat coil and/or radiant panel (if applicable) to maintain setpoint. A velocity sensor controls the intake air flow between minimum and maximum settings. The minimum air flow setting is adjusted based on the need for reheat. Return air is introduced into the return side of the box to balance the intake air flow so that the discharge air is constant. The fan runs continuously during occupied periods and the reheat valve modulates. Fans start 5 minutes before the air handling unit starts. When the central system is off, the primary air damper is closed. When Unoccupied, the fan cycles as required (with the reheat valve open) to maintain the unoccupied setpoint. Science / Art Rooms - When the local fume hood is energized, the minimum air flow setting is increased to 50 %. When the local room exhaust fan is energized, the VAV box opens to 100 % flow.

3.8. Multizone HVAC Sequence of Operations:

3.8.1. Discretionary Fire Alarm Shutdown Mode:

The supply fan is off, the return fan is off (where applicable) and power exhaust fan is off (where applicable), the outdoor air mixing dampers are in the 0% outdoor air position, heating is disabled and cooling is disabled. The zone dampers are in the 50 % cooling position. This is not intended to replace the hard-wired fan shutdown provided by others when required by Code. Normal HVAC unit functions are auto restored on relay signal from the fire alarm panel reset.

- 3.8.2. Freeze-stat Shutdown Mode(s):
- 3.8.2.1. Software
The duct/unit mounted supply air temperature sensor acts as a software freeze-stat (triggered below 1 °C after 3 minute delay, restored above 5 °C after 3 minute delay and auto reset after 5 minute delay)
- 3.8.2.2. Hard-Wired
In addition BAS monitors status of the hard wired freeze-stat (provided by others, where applicable) that shuts down the AHU fan(s) and spring closes the outside air damper(s) if the air temperature leaving the heating coil falls below the freeze-stat setpoint.
- 3.8.3. Unoccupied Mode:
Mode is active usually between 11:00 p.m. to 7:00 a.m. Monday to Friday and 24 hours Saturday and Sunday.
The system will be in Unoccupied Mode when not in Morning Warmup, Occupied or Standby modes.
The system will cycle between Idle State, Heating State or Pushbutton Override States to meet the demands from each state and return to the Idle State when the demands are satisfied.
- 3.8.3.1. (Idle State)
The supply fan is off, the return fan is off (where applicable) power exhaust fan is off (where applicable), the Global Ventilation Schedule is disabled, the outdoor air mixing dampers are in the 0 % outdoor air position, heating is disabled and cooling is disabled. The zone dampers are in the 50 % cooling position.
- 3.8.3.2. (Heating State)
System cycles on a call for unoccupied heating
Supply fan cycles on, associated exhaust or return fan cycles on (where applicable).
A full call for (all stages or full heat modulation where applicable) heating until setpoint is reached.
For modulating burners, (where applicable) 0 % signal (0 Volts) heating discharge temperature setpoint is at minimum discharge temperature (typically set on the multizone unit to 17 °C). A 100 % signal (10 Volts) heating discharge temperature setpoint is at maximum discharge temperature setpoint (typically set on the multizone unit to 35 °C).
Associated zone damper(s) modulate to obtain setpoint.
Unoccupied Heating temperature nominally 16.0 °C space temperature setpoint with an increased space temperature setpoint to 17.0 °C at -10.0 °C Outdoor Air Temperature or lower and 18.0 °C at -20.0 °C Outdoor Air Temperature or lower (each adjustable)
Mechanical Cooling: Disabled
Free Cooling: Disabled
Global Ventilation Schedule: Disabled
- 3.8.3.3. (Push Button Override State)
The default room temperature setpoint remains unchanged.
Idle state of the unoccupied mode is exited if the override pushbutton is pressed, (for a minimum of 2 seconds) at any room sensor.
The associated system will switch to the Occupied Mode for 2 hours (adjustable).
Free Cooling: Disabled
Mechanical Cooling: Enabled
Global Ventilation: Enabled
The system returns to idle state in the unoccupied mode after the 2 hours after the pushbutton trigger has elapsed.
- 3.8.4. Morning Warmup Mode:
An optimized start, based on the time of day schedule, outdoor air temperature and the lowest indoor zone temperature is provided for heating.
The Global Ventilation Schedule is disabled. The supply fan is on, the return fan is on (where applicable), the outdoor air mixing dampers are in the 0 % outdoor air position, heating is enabled at full capacity and the cooling is disabled.
The zone dampers modulate to maintain space temperature.
The optimized start program is to begin up to 105 minutes (adjustable) before the occupancy schedule to allow for morning warm up to bring the lowest zone temperature up to occupancy setpoint.
Free Cooling: Disabled
Mechanical Cooling: Disabled
Global Ventilation Schedule: Disabled
The system exits Morning Warm Up Mode and continues into occupied mode when the lowest indoor zone temperature is warmed up to default room temperature setpoint.
- 3.8.5. Occupied Mode:
Time of day schedule, which starts the unit along with an Optimum Start program usually between 7:00 a.m. and 4:00 p.m. Monday to Friday, when not overridden by a Holiday Schedule, Standby Occupancy Mode or Unoccupied Mode.
Global Ventilation Schedule is enabled.
Unit fan status confirmed by current sensing device(s) or VFD feedback.
Fan operation: The supply fan and return fan (where applicable) run continuously.
Room heating temperature setpoint nominal: 21.5 °C +/- 1.0 °C (adjustable)

Room Free Cooling Enabled temperature setpoint nominal 22.5 °C +/-1.0 °C
Room mechanical cooling temperature setpoint nominal 24.5 °C +/- 1.0 °C (adjustable)
Global Ventilation Schedule: Enabled

3.8.6. Standby Occupancy Mode:

Time of day schedule starts the HVAC unit(s) usually between 4:00 p.m. and 11:00 p.m. Monday to Friday.
Minimum outdoor air is set to zero when the global ventilation schedule is off.
Fan operation: Supply fan and return fan (where applicable) runs only on a call from heating or cooling.
Ventilation normally set to zero (with a future provision to adjust).
Room heating temperature setpoint nominal: 21.5 °C +/- 1.0 °C (adjustable)
Room Mechanical Cooling temperature setpoint nominal 24.5 °C +/- 1.0 °C (adjustable)
Free Cooling: Disabled
Global Ventilation Schedule: Disabled

3.8.7. Zone Damper Control

3.8.8. The room temperature sensor modulates the zone damper to maintain the occupied room temperature setpoint. Local setpoint adjustment is provided

3.8.9. Ventilation Lockout (Sequence):

When the ventilation lockout switch, usually located in the Custodial Office, is engaged, all outdoor air dampers close, free cooling is disabled, and the system switches to Standby Occupancy Mode of operation.

3.8.10. Heating Sequence:

3.8.10.1. Outdoor Air Temperature used to determine Heating Enable Mode:

A set of thresholds that are user adjustable at a global (board wide) or local (site specific) level, triggers the heating enable mode based on the Outdoor Air Temperature below the threshold. The threshold is further adjusted by a calendar schedule.
Typical default values are: 16 °C from September to May and 5 °C from June to August.

3.8.10.2. Default Setpoint:

When the Heating Mode is active, the default room temperature setpoint remains unchanged.

3.8.10.3. Call for Heating:

3.8.10.4. Hot Deck

Mechanical heating is used until the heating calls (from hot deck controller PID or Night Setback thresholds) are satisfied.
For Modulating Burners, (where applicable) 0 % signal (0 Volts) heating discharge temperature setpoint is at minimum hot deck temperature (typically set on the rooftop unit to 17 °C). A 100% signal (10 Volts) heating discharge temperature setpoint is at maximum hot deck temperature setpoint (typically set on the rooftop unit to 35 °C).
The hot deck temperature sensor regulates heating output to maintain the hot deck heating setpoint.
The power exhaust fan or return fan (if applicable) cycles based on the rooftop economizer position.
The hot deck sensor resets the setpoint of the burner controller (modulating burner controlled by the rooftop unit heating controller according to hot deck temperature) based on the coldest zone deviation from setpoint as follows:

Deviation Hot Deck Setpoint

0.0 °C Minimum (17 °C)
-2.0 °C Maximum (35 °C)

Hydronic

For Heating Valve, (where applicable) 0 % signal (10 Volts) closes the heating valve. A 100 % signal (below 2 Volts) opens the heating valve.

Radiation Zone

Where there is a zone served by radiation, the radiation valve opens (where applicable) and is to be substituted as the first stage of heating.

3.8.11. Cooling Sequence:

3.8.11.1. Outdoor air temperature used to determine cooling enable mode:

A set of thresholds that are user adjustable at a global (board wide) or local (site specific) level, triggers the cooling enable mode based on the outdoor air temperature exceeding the threshold. The threshold is further adjusted by a calendar schedule. Typical default values are: 18 °C from September to May and 21 °C from June to August.

3.8.11.2. Default Setpoint:

When the cooling enable mode is active, the default room temperature setpoint is raised by 3 °C.

3.8.11.3. Call for Cooling:

3.8.11.4. Cold Deck

When free cooling is available, and a demand for cooling is in place, free cooling will be used first, and if the demand for cooling is still in place, mechanical cooling will be used until the cooling calls (from cold deck controller PID) are satisfied.

The cold deck temperature sensor also modulates the mixing dampers (for free cooling) to maintain the cold deck setpoint.

The cold deck temperature sensor modulates the mixing dampers to maintain the cold deck setpoint which is reset based on the warmest zone deviation from setpoint as follows:

Deviation Cold Deck Setpoint

0.5 °C 20 °C

2 °C 13 °C

Zone Damper Control:

(same as heating sequence) The room temperature sensor modulates the zone damper to maintain the occupied room temperature setpoint.

3.8.12. Ventilation Sequence:

Not applicable as hot deck and cold deck temperatures are maintained to setpoint simultaneously.

3.8.13. Economizer Operation (and CO₂ Demand Control Ventilation) :

3.8.13.1. During Occupied Mode, economizer operation will be substituted for first stage mechanical cooling when the outdoor air temperature and relative humidity are below the Free Cooling Setpoint Sequence of Operation. If the outdoor air temperature is below this free cooling setpoint the mixing dampers will be modulated open on a call for cooling to provide 'free' cooling.

3.8.13.2. Minimum outdoor air damper position signal may exceed the economizer signal. A typical value for minimum outdoor air damper position is 5 % outdoor air, (0 % when an associated stand alone ERV is present) which can vary based on use case of the occupied space based on ASHRAE 62.1 net occupiable floor area outdoor air rate.

3.8.13.3. For units with power exhaust, the exhaust fan runs when the outdoor air damper is more than 50 % open.

3.8.13.4. During morning warm-up, the outdoor air minimum position is set to zero.

3.8.13.5. During Unoccupied Mode and Standby Occupancy Mode, free cooling is unavailable.

3.8.13.6. During Occupied Mode, If the outdoor air temperature and relative humidity are above the Free Cooling Setpoint Sequence of Operation, the mixing dampers will be set to the minimum outdoor air threshold unless otherwise required under ASHRAE 62.1 Ventilation Rate Procedure - net occupiable floor area outdoor air rate (w/ CO₂ demand controlled ventilation reset).

3.8.13.7. Each return air duct-mounted or space mounted CO₂ sensor acts as a high limit and will increase the amount of minimum outdoor air, to a maximum of 40 % outdoor air as the CO₂ level increases from 1000 ppm to 1200 ppm over a ramped 15 minute period).

3.8.13.8. CO₂ levels are automatically logged at 10 minute intervals (adjustable).

3.8.14. Additional Rooms Partition Switch

Any additional room(s) (i.e. Music Rooms) that are separated by a partition wall, will disable mechanical cooling (where applicable) for the associated units that serve the additional room(s). If the Music Room wall is open to the Gym, mechanical cooling serving the Music Room is disabled. Partition switch and lamacoid label to be provided above Music Room Sensor by the Building Automation Contractor. Label to read "No Cooling when Partition is Open to Gym".

3.8.15. Limits and Safeties

3.8.15.1. The maximum outdoor air damper position is limited based on the outdoor air temperature to prevent excessively low supply air temperature. At -15 °C or below, outdoor air temperature, the maximum outdoor air damper position will be 0 % open and at 10 °C outdoor air temperature, the maximum outdoor air damper position will be 100 %.

3.8.15.2. The maximum outdoor air damper position is limited based on the outdoor air temperature to prevent excessively high supply air temperature. At 30 °C outdoor air temperature and above, the maximum outdoor air damper position will be 0 % open and at 10 °C outdoor air temperature, the maximum outdoor air damper position will be 100 %

3.8.15.3. The mixed air temperature sensor acts as a low limit to ensure temperature does not fall below setpoint (typically 11 °C). In applications where the mixed air sensor is located after the DX cooling coil, the setpoint is reduced (to typically 5 °C) when DX cooling is enabled.

3.8.15.4. The hot deck air temperature sensor acts as a high limit for each stage of heating (for stage 1: disable above 60 °C , and enable below 50 °C, for stage 2: disable above 55 °C and enable below 45 °C) and the cold deck air temperature sensor a low limit for each stage of cooling (for stage 1: disable DX1 below 5°C and enable DX1 above 10 °C, for stage 2: below 8 °C disable DX2 and above 13 °C enable DX2).

3.8.15.5. The hot deck air temperature sensor acts as a software freezestat (triggered below 1 °C for 3 minutes, restored above 5 °C for 3 minute) auto reset after 5 minute delay.

3.8.15.6. The supply fan has a delay-off time of 90 seconds.

3.8.15.7. The DX cooling has a minimum-off time of 5 minutes.

- 3.8.15.8. DX cooling is disabled when the outdoor air temperature is below global DX disable setpoint (typically 2 °C below Cooling Enable setpoint) or when fan is off.
- 3.8.15.9. Gas heating is disabled when the outdoor air temperature is above the global heating disable setpoint (typically 2 °C above Heating Enable setpoint) or when the fan is off.
- 3.8.15.10. Stage 1 gas heating (where applicable for units with multiple stages of heating) has a minimum run time of 3 minutes.
- 3.8.15.11. Cooling cannot turn on until heating has been off for a minimum of 5 minutes.
- 3.8.15.12. During Occupied Mode, and the outdoor air is above -1 °C, heating stage 2 (where applicable) has a delay-on time of 15 minutes, except when the outdoor air temperature is below -3 °C with a +2 °C deadband.
- 3.8.15.13. The default zone setpoint is increased by 3°C when mechanical cooling is enabled (providing heating is disabled). The standard mechanical cooling setpoint will be limited to a (minimum of 23.5 °C - adjustable).
- 3.8.15.14. When the ventilation lockout switch (usually located at the custodial office) is engaged, the outdoor air dampers close, free cooling is disabled, and the system switches to Standby Occupancy Mode.
- 3.8.15.15. Minimum outdoor air is provided when enabled by the Global Ventilation Schedule.
- 3.8.15.16. The return air carbon dioxide sensor acts as a high limit to increase the amount of minimum outdoor air from 0 to 40 % as the reading increases from 1000 ppm to 1200 ppm.
- 3.8.15.17. Cooling cannot turn on until heating has been off for a minimum of 5 minutes.
- 3.8.15.18. During Occupied Mode, and the outdoor air is above -1°C, heating stage 2 (where applicable) has a delay-on time of 15 minutes, except when the outdoor air temperature is below -3°C with a +2°C deadband.
- 3.8.15.19. Minimum outdoor air is set to zero when the Global Ventilation Schedule is off.

3.8.16. **Alarms:**

An alarm will be generated upon the following conditions:

- 3.8.16.1. Fan status does not match the start/stop signal.
- 3.8.16.2. Mixed air temperature too high alarm (triggered above 50 °C and restored below 48 °C) or too low alarm (triggered below 5 °C and restored above 7 °C). Low mixed air temperature alarm set to lower thresholds when Mixed Air Temperature sensor is installed after the DX/cooling coil.
- 3.8.16.3. Hot deck air temperature too high alarm (triggered above 45 °C and restored below 43 °C) or sensor fault.
- 3.8.16.4. Cold deck air temperature too low alarm (triggered below 5 °C and restored above 7 °C) or sensor fault.
- 3.8.16.5. Zone temperature too high alarm (triggered above 42 °C and restored below 40 °C) for non-cooling systems, (triggered above 38 °C and restored below 36 °C) for cooling systems.
- 3.8.16.6. Zone temperature too low alarm (triggered below 14 °C and restored above 16°C).
- 3.8.16.7. Weekly fan runtime limit exceeded.
- 3.8.16.8. Return air CO₂ too high alarm (triggered above 1700 ppm and restored below 1650 ppm) or too low alarm (triggered below 250 ppm and restored above 300 ppm) with a 15 minute delay.
- 3.8.16.9. Software freezestat tripped.

3.9. Heat Pump Gas Fired Multi Zone Sequence of Operations

3.9.1. **System Integration Guidelines:**

3.9.1.1. **Output Points**

All CME multizone equipment points (fan speed, outdoor damper, heating, cooling, exhaust fans) are connected directly to the CME Multi Zone manufacturer's PMZ controller commanded indirectly through parameters via BACnet MS/TP.

3.9.1.2. **Input Points:**

Zone temperature, setpoint adjust, pushbutton overrides are provided by the Control Contractor, interfaced into the BAS system and the data is sent to the PMZ controller via BACnet MS/TP.

Supply air temperature, Return air temperature, Return Air Carbon Dioxide sensors, Fan Low Speed Status, Fan High Speed Status are connected directly to the Multi Zone manufacturer's PMZ controller. The data from the PMZ is read by the BAS via BACnet MS/TP).

3.9.1.3. **Setpoints and Schedules**

Setpoints and Schedules are determined as detailed in the following Sequence of Operations and are sent to the PMZ controller via BACnet MS/TP

3.9.2. **Discretionary Fire Alarm Shutdown Mode:**

The supply fans are off and power exhaust fans are off (where applicable), the outdoor air dampers are in the 0% outdoor air position, heating is disabled and cooling is disabled. The two-position zone dampers (where applicable) are in the closed position. This is not intended to replace the hard-wired fan shutdown provided by others when required by Code. Normal HVAC unit functions are auto restored on relay signal from the fire alarm panel reset.

3.9.3. Freeze-stat Shutdown Mode(s):

3.9.3.1. Software

The duct/unit mounted supply air temperature sensor (connected to the Multizone manufacturer's PMZ controller and monitored via BACnet MS/TP) acts as a software freeze-stat (triggered below 1 °C after 1 minute delay, restored above 5 °C after 5 minute delay).

3.9.3.2. Hard-Wired

In addition BAS monitors status of the hard wired freeze-stat (provided by others, where applicable) that shuts down the AHU fan(s) and spring closes the outside air damper(s) if the air temperature leaving the heating coil falls below the freeze-stat setpoint.

3.9.4. Unoccupied Mode:

Mode is active usually between 11:00 p.m. to 7:00 a.m. Monday to Friday and 24 hours Saturday and Sunday.

The system will be in Unoccupied Mode when not in Morning Warmup, Occupied or Standby modes.

The system will cycle between Idle State, Heating State or Pushbutton Override States to meet the demands from each state and return to the Idle State when the demands are satisfied.

3.9.4.1. (Idle State)

The supply fan is off, the power exhaust fans are off (where applicable), the Global Ventilation Schedule is disabled, the outdoor air dampers are in the 0 % outdoor air position, heating is disabled and cooling is disabled. The two-position zone dampers are in the closed position.

3.9.4.2. (Heating State)

System cycles on a call for unoccupied heating (which is triggered by the System Minimum Zone Temperature falling below the Unoccupied Heating Room Setpoint).

Supply fan cycles on..

A full call for (all stages or full heat modulation where applicable) heating until setpoint is reached.

Unoccupied Heating Room Temperature Setpoint nominally 16.0 °C space temperature setpoint with an increased space temperature setpoint to 17.0 °C at -10.0 °C Outdoor Air Temperature or lower and 18.0 °C at -20.0 °C Outdoor Air Temperature or lower (each adjustable).

The outdoor air temperature is also used to determine the heat-pump heating enable point. Below the heat-pump enable outdoor air temperature setpoint the heating is provided by gas fired heating.

ADD HEAT PUMP HEATING MODE when OAT is 5C or greater ? (adjustable)

Mechanical Cooling: Disabled

Free Cooling: Disabled

Global Ventilation Schedule: Disabled

3.9.4.3. (Push Button Override State)

The default room temperature setpoint remains unchanged.

Idle state of the unoccupied mode is exited if the override pushbutton is pressed, (for a minimum of 2 seconds) at any room sensor. The associated system will switch to the Occupied Mode for 2 hours (adjustable).

Free Cooling: Disabled

Mechanical Cooling: Enabled

Global Ventilation: Enabled

The system returns to idle state in the unoccupied mode after the 2 hours after the pushbutton trigger has elapsed.

3.9.5. Morning Warmup Mode:

An optimized start, based on the time of day schedule, outdoor air temperature and the lowest indoor zone temperature is provided for heating.

The Global Ventilation Schedule is disabled. The furnace supply fans are on (at high speed when heating is required), the outdoor air mixing dampers are in the 0 % outdoor air position, heating is enabled and the cooling is disabled.

The zone dampers open (where applicable) to maintain space temperature.

The optimized start program is to begin up to 105 minutes (adjustable) before the occupancy schedule to allow for morning warm up to bring the lowest zone temperature up to occupancy setpoint.

Free Cooling: Disabled

Mechanical Cooling: Disabled

Global Ventilation Schedule: Disabled

The system exits Morning Warmup Mode and continues into occupied mode when the lowest indoor zone temperature is warmed up to default room temperature setpoint.

3.9.6. Occupied Mode:

Time of day schedule, which starts the unit along with an Optimum Start program usually between 7:00 a.m. and 4:00 p.m. Monday to Friday, when not overridden by a Holiday Schedule, Standby Occupancy Mode or Unoccupied Mode.

Global Ventilation Schedule is enabled.

Unit fan status confirmed by current sensing device(s) or VFD feedback.

Fan operation: The supply fan runs continuously and the exhaust fans stage on as required.

Room heating temperature setpoint nominal: 21.5 °C +/- 1.0 °C (adjustable)

Room Free Cooling Enabled temperature setpoint nominal 22.5 °C +/-1.0 °C

Room mechanical cooling temperature setpoint nominal 24.5 °C +/- 1.0 °C (adjustable)

Global Ventilation Schedule: Enabled

3.9.7. Standby Occupancy Mode:

Time of day schedule starts the HVAC unit(s) usually between 4:00 p.m. and 11:00 p.m. Monday to Friday.

Minimum outdoor air is set to zero (with future provision to adjust) when the global ventilation schedule is off. .

Ventilation normally set to zero (with a future provision to adjust).

Room heating temperature setpoint nominal: 21.5 °C +/- 1.0 °C (adjustable)

Room Mechanical Cooling temperature setpoint nominal 24.5 °C +/- 1.0 °C (adjustable)

Free Cooling: Disabled

Global Ventilation Schedule: Disabled

3.9.8. Zone Damper Control

The zone temperatures are monitored and sent to the manufacturer supplied PMZ controller.

Zone space temperature sensors open their respective two-position zone damper (where applicable) to maintain setpoint. An adjustment of +/-1°C is provided at each room temperature sensor. The default space temperature setpoint is raised 3 °C when DX cooling is enabled.

The zone dampers are set to minimum ventilation air flow by the balancer when 'closed'. To maintain minimum ventilation air during Occupied Mode

3.9.9. Ventilation Lockout (Sequence):

When the ventilation lockout switch, usually located in the Custodial Office, is engaged, all outdoor air dampers close, free cooling is disabled, and the system switches to Standby Occupancy Mode of operation.

3.9.10. Heating Sequence:

3.9.10.1. Outdoor Air Temperature used to determine Heating Enable Mode:

A set of thresholds that are user adjustable at a global (board wide) or local (site specific) level, triggers the heating enable mode based on the Outdoor Air Temperature below the threshold. The threshold is further adjusted by a calendar schedule.

Typical default values are: 16 °C from September to May and 5 °C from June to August.

The outdoor air temperature is also used to determine the heat-pump heating enable point. Below the heat-pump enable outdoor air temperature setpoint the heating is provided by gas fired heating.

3.9.10.2. Default Setpoint:

When the Heating Mode is active, the default room temperature setpoint remains unchanged.

3.9.10.3. Call for Heating:

3.9.10.4. Dedicated Furnace

The furnace fan goes into high speed during heating mode.

Mechanical heating is used until the heating calls (from Furnace controller PID or Night Setback thresholds) are satisfied.

Condensers act as heat pumps and provide heating until outside air temperature falls below 5 °C (Adjustable based on defrost operation).

Below this heat-pump outdoor air temperature setpoint the gas heating is used to provide heating.

Radiation Zone

Where there is a zone served by radiation, the radiation valve opens (where applicable) and is to be substituted as the first stage of heating.

3.9.11. Cooling Sequence:

3.9.11.1. Outdoor air temperature used to determine cooling enable mode:

A set of thresholds that are user adjustable at a global (board wide) or local (site specific) level, triggers the cooling enable mode based on the outdoor air temperature exceeding the threshold. The threshold is further adjusted by a calendar schedule. Typical default values are: 18 °C from September to May and 21 °C from June to August.

3.9.11.2. Default Setpoint:

When the cooling enable mode is active, the default room temperature setpoint is raised by 3 °C.

3.9.11.3. Call for Cooling:

3.9.11.4. Dedicated Furnace

The furnace fan goes into high speed during cooling mode.

When free cooling is available, and a demand for cooling is in place, free cooling will be used first, and if the demand for cooling is still in place, mechanical cooling will be used until the cooling calls controller PID are satisfied.

Zone Damper Control:

The zone temperatures are monitored and sent to the manufacturer supplied PMZ controller.

Zone space temperature sensors open their respective two-position zone damper to maintain setpoint. An adjustment of +/-1.5°C is provided at each room temperature sensor. The default space temperature setpoint is raised 3 °C when DX cooling is enabled.

3.9.12. Ventilation Sequence:

The outdoor air flow rate is calculated according to each fan speed and outdoor air damper position and this cycles on the exhaust fans to balance the air flow.

3.9.13. Economizer Operation (and CO₂ Demand Control Ventilation) :

3.9.13.1. During Occupied Mode, economizer operation will be substituted for first stage mechanical cooling when the outdoor air temperature and relative humidity are below the Free Cooling Setpoint Sequence of Operation. If the outdoor air temperature is below this free cooling setpoint the outdoor air dampers will be modulated open on a call for cooling to provide 'free' cooling.

3.9.13.2. Minimum outdoor air damper position signal may exceed the economizer signal. A typical value for minimum outdoor air damper position is 10 % outdoor air, (0 % when an associated stand alone ERV is present) which can vary based on use case of the occupied space based on ASHRAE 62.1 net occupiable floor area outdoor air rate.

3.9.13.3. For units with power exhaust, the exhaust fans stage on when the outdoor air damper is more than 50 % open.

3.9.13.4. During morning warm-up, the outdoor air minimum position is set to zero.

3.9.13.5. During Unoccupied Mode and Standby Occupancy Mode, free cooling is unavailable.

3.9.13.6. During Occupied Mode, If the outdoor air temperature and relative humidity are above the Free Cooling Setpoint, the mixing dampers will be set to the minimum outdoor air position unless otherwise required under ASHRAE 62.1 Ventilation Rate Procedure - net occupiable floor area outdoor air rate (w/ CO₂ demand controlled ventilation reset).

3.9.13.7. Each return air duct-mounted or space mounted CO₂ sensor acts as a high limit and will increase the amount of minimum outdoor air, to a maximum of 40 % outdoor air as the CO₂ level increases from 1000 ppm to 1200 ppm over a ramped 15 minute period).

3.9.14. Additional Rooms Partition Switch

3.9.14.1. Any additional room(s) (i.e. Music Rooms) that are separated by a partition wall, will disable mechanical cooling (where applicable) for the associated units that serve the additional room(s). If the Music Room wall is open to the Gym, mechanical cooling serving the Music Room is disabled. Partition switch and lamacoid label to be provided above Music Room Sensor by the Building Automation Contractor. Label to read "No Cooling when Partition is Open to Gym"

3.9.15. Limits and Safeties

3.9.15.1. The maximum outdoor air damper position is limited based on the outdoor air temperature to prevent excessively low supply air temperature. At -15 °C or below, outdoor air temperature, the maximum outdoor air damper position will be 0% open and at 10 °C outdoor air temperature, the maximum outdoor air damper position will be 100 %.

3.9.15.2. The maximum outdoor air damper position is limited based on the outdoor air temperature to prevent excessively high supply air temperature. At 30 °C outdoor air temperature and above, the maximum outdoor air damper position will be 0% open and at 10 °C outdoor air temperature, the maximum outdoor air damper position will be 100 %

3.9.15.3. The supply air temperature sensor acts as a high limit for each stage of heating (for stage 1: disable above 60 °C, and enable below 50 °C, for stage 2: disable above 55 °C and enable below 45 °C) and the cold deck air temperature sensor a low limit for each stage of cooling (for stage 1: disable DX1 below 5°C and enable DX1 above 10 °C, for stage 2: below 8 °C disable DX2 and above 13 °C enable DX2).

3.9.15.4. The supply air temperature sensor acts as a software freezestat (triggered below 1 °C for 1 minute, restored above 5 °C for 1 minute) auto reset after 5 minute delay.

3.9.15.5. The supply fan has a delay-off time of 90 seconds.

3.9.15.6. The DX cooling has a minimum-off time of 5 minutes.

3.9.15.7. DX cooling is disabled when the outdoor air temperature is below global DX disable setpoint (typically 2 °C below Cooling Enable setpoint) or when fan is off.

3.9.15.8. Gas heating is disabled when the outdoor air temperature is above the global heating disable setpoint (typically 2 °C above Heating Enable setpoint) or when the fan is off.

3.9.15.9. Stage 1 gas heating (where applicable for units with multiple stages of heating) has a minimum run time of 3 minutes.

3.9.15.10. Cooling cannot turn on until heating has been off for a minimum of 5 minutes.

3.9.15.11. During Occupied Mode, and the outdoor air is above -1 °C, heating stage 2 (where applicable) has a delay-on time of 15 minutes, except when the outdoor air temperature is below -3 °C with a +2 °C deadband.

- 3.9.15.12. The default zone setpoint is increased by 3 °C when mechanical cooling is enabled (providing heating is disabled). The standard mechanical cooling setpoint will be limited to a (minimum of 23.5 °C - adjustable).
- 3.9.15.13. When the ventilation lockout switch (usually located at the custodial office) is engaged, the outdoor air dampers close, free cooling is disabled, and the system switches to Standby Occupancy Mode.
- 3.9.15.14. Minimum outdoor air is provided when enabled by the Global Ventilation Schedule.
- 3.9.15.15. The return air carbon dioxide sensor acts as a high limit to increase the amount of minimum outdoor air from 0 to 40 % as the reading increases from 1000 ppm to 1200 ppm.
- 3.9.15.16. During Occupied Mode, and the outdoor air is above -1°C, heating stage 2 (where applicable) has a delay-on time of 15 minutes, except when the outdoor air temperature is below -3°C with a +2°C deadband.
- 3.9.15.17. Minimum outdoor air is set to zero when the Global Ventilation Schedule is off.

3.9.16. **Alarms:**

- 3.9.16.1. An alarm will be generated upon the following conditions:
- 3.9.16.2. Fan status does not match the start/stop signal.
- 3.9.16.3. Supply air temperature too high alarm (triggered above 45 °C and restored below 43 °C) or sensor fault.
- 3.9.16.4. Supply air temperature too low alarm (triggered below 5 °C and restored above 7 °C) or sensor fault.
- 3.9.16.5. Zone temperature too high alarm (triggered above 42 °C and restored below 40 °C) for non-cooling systems, (triggered above 38 °C and restored below 36 °C) for cooling systems.
- 3.9.16.6. Zone temperature too low alarm (triggered below 14 °C and restored above 16°C).
- 3.9.16.7. Weekly fan runtime limit exceeded.
- 3.9.16.8. Return air CO₂ too high alarm (triggered above 1700 ppm and restored below 1650 ppm) or too low alarm (triggered below 250 ppm and restored above 300 ppm) with a 15 minute delay.
- 3.9.16.9. Software freezestat tripped.

3.10. Hydronic Boiler Sequence of Operations:

3.10.1. System Enable/Disable Criteria for Winter Mode:

Winter Mode is active between September 16 and May 15.

When Winter Mode is active the boiler system is enabled no matter what the outdoor air temperature is so that a failure of the outdoor air temperature sensor or the networking of it to other controllers does not cause a no-heat condition.

Once the boiler system is enabled, the sequence is followed starting with 3.9.3 Hot Water Supply Setpoint Determination.

3.10.2. System Enable/Disable Criteria for Summer Mode:

Summer Mode is active between May 16 and September 15.

The boiler system is enabled when the outdoor air temperature is lower than 4 °C and disabled when the outdoor air temperature goes above 4 °C with a 2 °C deadband.

Once the boiler system is enabled, the sequence is followed starting with 3.9.3 Hot Water Supply Setpoint Determination.

When the boiler system is disabled in summer mode, the boilers, main and circulation pumps are shut off.

The primary heating pumps have a delay-off time of 5 minutes.

3.10.3. Changeover from Summer to Winter Mode:

Inter-boiler Runtime Delay: The lead boiler must run at least 5 minutes before the next boiler can start.

The delay is increased to 30 minutes when switching from summer to winter operation.

3.10.4. Hot Water Supply Temperature Setpoint Determination

Base Calculation: The base hot water supply temperature setpoint is reset from the outdoor air temperature as per the following linear reset schedule (adjustable):

For non-condensing boilers:

Qat | HwstSp

16 °C 60 °C

-20 °C 90 °C

The hot water supply temperature setpoint is further reset +5 °C to maintain boiler entering water above 55 °C to minimize condensation:

Hwrt | HwstSpAdd

52 °C 5 °C

55 °C 0 °C

For condensing boilers:

Qat | HwstSp

16 °C 50 °C

-20 °C 80 °C

The hot water supply temperature setpoint is further reset -5 °C to maintain boiler entering water below 52 °C to promote condensation:

Hwrt | HwstSpAdd

49 °C 0 °C

52 °C -5 °C

3.10.5. Morning Warm-Up Mode:

During the optimum start, the boiler system system will be in Morning Warm-Up Mode.

The optimized start program, based on outdoor air temperature and time of day schedule, is to begin up to 120 minutes (adjustable) before the occupancy schedule to allow for morning warm up.

The optimized start time is calculated based on how long the hot water supply temperature has historically taken to reach setpoint at the current outdoor air temperature.

The hot water supply temperature setpoint has a +10 °C offset added during morning warm-up mode.

3.10.6. Unoccupied Mode:

Unoccupied Setback Offset: The hot water supply temperature setpoint is reduced by -5 °C for unoccupied setback.

3.10.7. Minimum Zone Temperature Deviation Reset:

The hot water supply temperature setpoint is also reset +/- 5 °C based on the minimum zone temperature deviation from setpoint.

3.10.8. Summary:

Final Hot Water Supply Temperature Setpoint = Base Calculation + Return Water Limit Protection + Minimum Zone Temperature Deviation Reset + Morning Warm-Up Offset + Unoccupied Setback Offset

Boilers are modulated by the BAS to maintain setpoint. Boilers are cycled on a call from supply water temperature in sequence to maintain the Final Hot Water Supply Temperature Setpoint.

For non-condensing boilers:

The control loop PID controls the hot water supply temperature to setpoint. The PID output is divided into the number of boilers.

For example for 4 primary boilers: each boiler would operate through 25% of the full 100% of the PID output. There is a 300 second delay between stages. First the lead boiler, then the lag1 boiler, then lag2, then lag3 as the PID output increases. The lead and lag boilers are reassigned weekly to equalize run-time.

For systems with special purpose boilers such as:

a) one modulating boiler working with other on/off boilers: it would run to maintain setpoint when there is less than one boiler's output required to meet the heating load in order to reduce cycling of the boilers.

b) one condensing boiler working with other non-condensing boilers: it would run during low heating loads in order to maximize condensing efficiency.

Condensing Boilers Sequence of Operation for a 2 boiler plant

The heating boilers operate when heating is enabled.

When heating is enabled the lead heating pump runs. (See the lead/lag heating pump sequence.)

The boilers are modulated to maintain the hot water supply temperature setpoint.

The hot water supply temperature setpoint is calculated from a combination of these often competing factors, which are site dependent:

a. the outdoor air temperature (to determine a general weather heating requirement)

b. return water temperature (to maximize condensing)

c. difference between supply and return temperatures (to assess building heat load)

d. maximum heating deviation (room temperature heating setpoint minus the room temperature - ramped up and down)

The overall heating requirement signal is produced from the output of a heating PID loop with the supply water temperature and the supply water temperature setpoint as inputs.

As the heating signal increases above the lead boiler start point (initially 30 % ON / 10 % OFF, all setpoints are adjustable), the lead boiler's circulation pump starts.

When this boiler circulation pump's status is verified on for 60 seconds, the lead boiler can start.

Then, if the heating signal is above the lead boiler start point, the boiler starts at its lowest output.

The lead boiler output is ramped up and down at 10 % per minute until it reaches 100 % output.

As the heating requirement increases above the lag boiler start point (initially 60 % ON / 50 % OFF), the lag boiler's circulation pump starts.

When this boiler circulation pump's status is verified on for 60 seconds, the lag boiler can start.

When the lag boiler starts, both boilers go to their minimum modulation outputs. They then modulate together, ramped at 10 % per minute from minimum to 100 % with the heating signal.

When the boilers have ramped down to their minimum modulation outputs based on the heating signal demand, and have been there for 60 seconds, the lag boiler is turned off.

The lag boiler circulation pump runs for 5 minutes or until the return and supply boiler water temperatures are within 1 °C of each other and then it shuts off.

The lead boiler then modulates alone (ramped) as required by the heating signal.

When the lead boiler is at minimum modulation output for 60 seconds it is turned off.

The lead boiler circulation pump runs for 5 minutes or until the return and supply boiler water temperatures are within 1 °C of each other and then it shuts off.

3.10.9. Lead/Lag operation:

Provided for boilers on a weekly basis. Typically rotated on a Tuesday at 1:00 p.m. when a new lead boiler is assigned. The next lag boiler is to start should the Lead Boiler fail to start.

The boiler circulating pumps are hard wired by the Mechanical Contractor to the local boiler controls and flow switch(s) so that each boiler starts when the associated pump is confirmed running through the flow switch(s). The boiler circulating pump current draws are monitored by BAS to determine status.

3.10.10. Main Heating Pumps:

Heating pumps P1 or P2 operate continuously when heat is enabled with weekly lead/lag operation, typically rotated on a Thursday at 1:00 p.m. when a new lead pump is assigned. (Lag pump starts if lead pump fails or is in alarm mode)

Main heating pumps are monitored by BAS for status.

Main heating pumps are exercised to run for 10 minutes once a week, typically lead pump on a Thursday at 1:00 p.m. and lag pump at 1:30 p.m. when the system is off in summer mode.

3.10.11. Main Pump Modulated Flow:

The main heating pump speed (normally controlled by a VFD provided by others) is modulated to maintain the minimum differential pressures of the multiple sensors (where applicable) at setpoint.

3.10.12. Limits and Safeties:

3.10.12.1. The supply water temperature setpoint is limited to operate between 45 °C and 105 °C.

3.10.12.2. Summer mode delay shutdown. The primary heating pumps have a delay-off time of 5 minutes.

3.10.12.3. Minimum Boiler Runtime with Circulating Pump Interlock: Each boiler must run at least 2 minutes before it will modulate above the minimum firing rate. The boilers cannot modulate up from the minimum fire until the boiler circulating pump status is on.

3.10.12.4. Inter-boiler Runtime Delay: The lead boiler must run at least 5 minutes before the next boiler can start. The delay is increased to 30 minutes when switching from summer to winter operation.

3.10.13. Alarms:

3.10.13.1. Hot water supply temperature too high alarm (triggered above 12 °C after a 600 second time delay and restored below 10 °C deviation from setpoint).

3.10.13.2. Hot water supply temperature too low alarm (triggered below -12 °C after a 300 second time delay and restored above -10 °C deviation from setpoint). (Alarm is routed to Heat Loss Alarm for notification of security staff).

3.10.13.3. Boiler alarm in an incorrect state (separate alarm for each).

3.10.13.4. Any pump in an incorrect state after a 300 second time delay (separate alarm for each).

3.10.13.5. Any VFD alarm (separate alarm for each).

3.10.13.6. Differential water pressure too high alarm (triggered above 5 psi after a 600 second delay and restored below 3 psi deviation from setpoint) or too low alarm (triggered below -5 psi after a 300 second delay and restored above -3 psi deviation from setpoint) (separate alarm for each).

3.11. Hydronic Heating Control Valves Sequence of Operations:

When a hydronic hot water wall fin/convectors, radiant panels, or similar perimeter heat serves a room that is also served by an associated fan system/rooftop unit, the hot water perimeter heat is to be sequenced (where appropriate) as the first stage of heating for each applicable zone.

The space sensor PID controller modulates the perimeter heat control valve as a first stage of heating for each applicable zone to maintain setpoint.

3.11.1. Hot Water Wallfin / Convectors / Radiant Panels

Non adjustable room temperature plate sensor or room temperature sensor with local setpoint adjust and pushbutton override is provided where indicated.

- 3.11.1.1. Perimeter Convector Heaters
Room sensor modulates the valve for heating to maintain room temperature setpoint, which is reduced during unoccupied hours.
Room sensor is used as low temperature alarm
- 3.11.1.2. Cabinet Unit Heaters
Space sensor cycles unit heater for heating to maintain setpoint.
Space sensor is used as low temperature alarm
- 3.11.1.3. Limits and Safeties
Hydronic heating control valves are to fail open to heat.
- 3.11.1.4. Alarms
An alarm is generated at the BAS when:
The space temperature is too low alarm (triggered below 14 °C and restored above 16 °C)
The space temperature is too high alarm (triggered above 38 °C and restored below 36 °C)
Low temperature alarm to be integrated through security to On-Call Response

3.12. In Floor Hydronic Heating Sequence of Operations: (use Moffat Creek as recent template - to be updated to include slab and wall sensor control)

The two-way in-floor heating valves are cycled by the slab temperature sensor and anticipator to maintain setpoint which is reset from minimum room temperature as follows:

| <u>Minimum Room Temp</u> | <u>Slab Temp</u> |
|--------------------------|------------------|
| 18°C | 27°C |
| 23°C | 22°C |

3.13. Hydronic Coils Chilled Water Control Valves Sequence of Operations: (merge with 3.6 and 3.15 and 3.16 if required)

Integral to applicable air handlers sequence of operation. Typically fails closed to coil.

3.14. Cooling Tower with Heat Pump Loop - Sequence of Operations: (ready for review)

- 3.14.1. Cooling Tower Disabled Mode
Cooling Tower Pump is disabled when the outdoor air temperature is below 10 °C (for exercising of chemicals in the sump)
- 3.14.2. Cooling Tower Enabled Mode
Cooling Tower Pump is enabled and runs continuously when the outdoor air temperature is above 6 °C.
- 3.14.3. Circulating Pump turns on when Loop Supply Temperature drops below 17 °C and Heat Exchanger Valve modulates to maintain 17 °C.
- 3.14.4. Cooling Mode Heat Pump Loop Supply Water Temperature Sensor controls two stages of cooling and modulates the heating valve in sequence to maintain setpoint.
- 3.14.4.1. On a call for cooling, the following sequence occurs: 17 °C to 20 °C Heat Exchanger valve modulates closed to heating and the heat exchanger circulating pump stops.
- 3.14.4.2. 22 °C to 23.5 °C Cooler discharge damper closed/opens and spray pump starts with 10 second delay ON.
- 3.14.4.3. 26 °C to 28 °C Cooler fan disable/enable with 10 second delay ON. Actual start/stop is controlled by the discharge damper controller.
- 3.14.5. Lead/Lag Control is provided for the two loop pumps on a weekly basis. If the flow switch indicates no flow, both pumps will run (resets every 4 hours).
- 3.14.6. Indication is provided for heat exchanger entering and leaving water temperature, loop return water temperature and cooler leaving water temperature.
- 3.14.7. Cooling Tower pump(s) are exercised to run for 5 minutes once a week, typically lead pump on a Thursday at 1:00 p.m. and lag pump at 1:30 p.m. when the system is on in summer mode. (Chemical tower basin chemical agitation).
- 3.14.8. Limits and Safeties
 - 3.14.8.1. Each output has a time delay-on of 10 to 20 seconds to prevent all equipment from starting at once.
 - 3.14.8.2. One loop pump is wired to fail on the 'on' position.
 - 3.14.8.3. The cooling tower pump is disabled when the outdoor air temperature is disabled below 5 °C and enabled above 6 °C.
 - 3.14.8.4. The cooling tower fan has a minimum off-time of 90 seconds.
 - 3.14.8.5. The cooling tower fan cannot start unless the discharge damper end switch is closed.
 - 3.14.8.6. Cooling tower pump is exercised once a day at 9:00 a.m. when the outdoor air temperature is above 6 °C.
 - 3.14.8.7. If the supply water temperature and return water temperature are out of range (for 4 minutes), all heat pumps stop and an alarm is generated at the BAS
- 3.14.9. Alarms
 - 3.14.9.1. Any Heating Loop Pump in incorrect mode.

- 3.14.9.2. Any Cooling Loop Pump in incorrect mode.
- 3.14.9.3. Low boiler supply water temperature alarm (triggered above 20 °C and restored below 25 °C, disabled when boiler is shut off).
- 3.14.9.4. High boiler supply water temperature alarm (triggered above 95 °C and restored below 93 °C).
- 3.14.9.5. Low boiler return water temperature alarm (triggered below 20 °C and restored above 25 °C, disabled when boiler is shut off).
- 3.14.9.6. High boiler return water temperature alarm (triggered above 92 °C and restored below 90 °C).
- 3.14.9.7. Cooling tower fan in incorrect mode.
- 3.14.9.8. Low loop return water temperature alarm (triggered below 15 °C and restored above 16 °C) or high loop return water alarm (triggered above 34 °C and restored below 33 °C).
- 3.14.9.9. Low loop supply water temperature alarm (triggered below 15 °C and restored above 16 °C) or high loop supply water temperature alarm (triggered above 34 °C and restored below 33 °C).
- 3.14.9.10. No flow in loop.
- 3.14.9.11. Cooling tower damper in the wrong position.

3.15. Chilled Water Cooling System Sequence of Operations: (centrifugal , screw chillers multi-stage scroll?)

3.15.1. Chiller Disabled Mode

Chiller is disabled when the outdoor air temperature is below 16 °C (adjustable).

3.15.2. Chiller Enabled Mode:

- 3.15.2.1. Interlock cooling enable mode with heating enable mode to ensure no simultaneous heating and cooling.
- 3.15.2.2. When the chiller is enabled, chilled water pumps run continuously. The lead chilled water pump speed is modulated to maintain the differential water pressure at setpoint. This setpoint is automatically adjusted during the day to maintain the control valve on the loop with the greatest demand at the near open to minimize pump energy. The chilled water supply sensor modulates the chiller to maintain the supply water temperature setpoint which is reset from the outdoor air temperature as follows:

| <u>OAT</u> | <u>CWST</u> |
|------------|-------------|
| 20 °C | 11 °C |
| 30 °C | 6 °C |

- 3.15.2.3. Main cooling pumps are exercised to run for 10 minutes once a week, typically lead pump on a Thursday at 1:00 p.m. and lag pump at 1:30 p.m. when the system is off in winter mode (for pump and valve exercising) Not applicable if systems are drained.

3.15.3. Limits and Safeties:

- 3.15.3.1. The chillers are enabled when the outdoor air temperature is greater than 16 °C for 60 minutes.
- 3.15.3.2. The enable temperature is reset up to 20 °C as the outdoor relative humidity falls from 50 %RH to 30 %RH.
- 3.15.3.3. Between September 15 and May 15, the chiller enable temperature is 22 °C.
- 3.15.3.4. The pumps delay off 5 minutes after the chiller is shut off.

3.15.4. Alarms:

- 3.15.4.1. Chilled water supply temperature too high alarm (triggered above 13 °C and restored below 11 °C) or too low alarm (triggered below 4 °C and restored above 6 °C).
- 3.15.4.2. Chiller Alarm
- 3.15.4.3. Any pump is in an incorrect state or VFD alarm.
- 3.15.4.4. Differential water pressure too high alarm (triggered above 5 psi above setpoint and restored 3 psi below setpoint) for 10 minutes.

3.16. Chilled Water Cooling Coils Sequence of Operations: (ready for review) (merge with 3.6 and 3.13. 3.15 if required)

3.16.1. Unoccupied Mode

The cooling coil valve is closed. There can be no unoccupied cooling. The perimeter heating is controlled to the unoccupied room heating setpoint.

3.16.2. Occupied Mode

The cooling coil valve modulates open when there is chilled water in the CW mains.

3.16.3. Limits and Safeties:

Cooling valves are closed when the outside air temperature is below the global cooling disable setpoint or the CW mains temperature is above 20°C.

3.16.4. Alarms

- 3.16.4.1. 1) Space temperature too high (triggered above 38 °C and restored below 36 °C) or too low (triggered below 14 °C and restored above 15 °C)

3.17. Ductless Split - Cooling Only Unit Sequence of Operations: (ready for review)

3.17.1. Unoccupied Mode

The system is off. If the pushbutton on the room sensor is pressed, the system will switch to the occupied mode for a period of 2 hours (adjustable).

3.17.2. Occupied Mode

The room temperature sensor cycles the ductless split to maintain the occupied cooling setpoint. Setpoint adjustment of +/-1 °C is provided. The unit is disabled when the outside air temperature is below the global mechanical cooling disable setpoint (initially disabled below 12 °C and enabled above 14 °C).

3.17.3. Limits and Safeties:

3.17.3.1. The cooling mode is disabled when heating mode is enabled and when the Outside Air Temperature is below the global mechanical cooling disable setpoint (initially disabled below 16 °C and enabled above 18 °C).

3.17.3.2. A minimum off-time of 5 minutes is provided.

3.17.3.3. Cooling setpoint is limited to a minimum of 23.5 °C.

3.17.4. Alarms

3.17.4.1. An alarm is generated at the BAS if the room temperature is too cold (triggered below 14 °C and restored above 15 °C) or too hot (triggered above 36 °C and restored below 35 °C).

3.17.4.2. The fan status does not match the start/stop point.

3.17.4.3. Weekly fan runtime limit exceeded.

3.18. Ductless Split - Heat Pump Sequence of Operations: (ready for review) first stage heating etc.

3.18.1. Unoccupied Mode

The system is off. If the pushbutton on the room sensor is pressed, the system will switch to the occupied mode for a period of 2 hours (adjustable).

3.18.2. Occupied Mode

The room temperature sensor cycles the ductless split heat pump to maintain the occupied cooling setpoint (typically 24.5 °C) or occupied heating setpoint (typically 21.5 °C). Setpoint adjustment of +/-1 °C is provided.

3.18.3. Limits and Safeties:

3.18.3.1. The cooling mode is disabled when heating mode is enabled and when the Outside Air Temperature is below the global mechanical cooling disable setpoint (initially disabled below 16 °C and enabled above 18 °C).

3.18.3.2. The heating mode is disabled when cooling mode is enabled and when the Outside Air Temperature is above the global heating disable setpoint (initially disabled above 14 °C and enabled below 12 °C).

3.18.3.3. A minimum off-time of 5 minutes is provided.

3.18.3.4. Heat pump is disabled if the condensate pump fails. Hard-wired into the condensate pump safeties switch.

3.18.3.5. Cooling setpoint is limited to a minimum of 23.5 °C.

3.18.3.6. Heating setpoint is limited to a maximum of 22 °C.

3.18.3.7. Heat Pump heat mode is disabled when Outside Air Temperature is below 5 °C.

3.18.4. Alarms

An alarm is generated at the BAS if:

3.18.4.1. The room temperature is too cold (triggered below 14 °C and restored above 15 °C) or too hot (triggered above 36 °C and restored below 35 °C).

3.18.4.2. The heat pump fan status does not match the start/stop point.

3.18.4.3. Weekly fan runtime limit exceeded.

3.19. Water to Air Heat Pump Unit Sequence of Operations: (ready for review)

3.19.1. Discretionary Fire Alarm Shutdown Mode:

The supply fan is off, heating is disabled and cooling is disabled. This is not intended to replace the hard-wired fan shutdown provided by others when required by Code. Normal Heat Pump Unit functions are auto restored on relay signal from the fire alarm panel reset.

3.19.2. Software Freeze-stat Shutdown Mode:

The duct/unit mounted supply air temperature sensor acts as a software freeze-stat (triggered below 1 °C after 3 minutes, restored above 5 °C after 3 minutes, and auto reset after 5 minute delay).

3.19.3. Unoccupied Mode:

Mode is active usually between 11:00 p.m. to 7:00 a.m. Monday to Friday and 24 hours Saturday and Sunday.

The system will be in Unoccupied Mode when not in Morning Warmup, Occupied or Standby modes. The system will cycle between Idle State, Heating State or Pushbutton Override States to meet the demands from each state and return to the Idle State when the demands are satisfied.

3.19.3.1. (Idle State)

The supply fan is off, heating is disabled and cooling is disabled.

3.19.3.2. (Heating State)

System cycles on a call for unoccupied heating. A full call for heating until setpoint is reached.

Heating temperature nominally 16.0 °C space temperature setpoint with an increased space temperature setpoint to 17.0 °C at -10.0 °C OAT or lower and 18.0 °C at -20.0 °C OAT or lower (each adjustable)

Mechanical Cooling: Disabled

3.19.3.3. (Push Button Override State)

If the override pushbutton is pressed, at any room sensor, the associated system will switch to the Occupied Mode for 2 hours (adjustable). With outdoor air ventilation and cooling enabled.

3.19.4. Morning Warmup Mode:

An optimized start, based on the time of day schedule of the associated Make Up Air Unit, outdoor air temperature and the lowest indoor zone temperature is provided for heating.

The supply fan is on, heating is enabled at full capacity and the cooling is disabled.

The optimized start program is to begin up to 105 minutes before the occupancy schedule to allow for morning warm up to bring the lowest zone temperature up to occupancy setpoint.

3.19.5. Occupied Mode:

Time of day schedule, which starts the associated Make Up Air unit along with an Optimum Start program usually between 7:00 a.m. and 4:00 p.m. Monday to Friday, when not overridden by a Holiday Schedule, Standby Occupancy Mode or Unoccupied Mode.

Global Ventilation Schedule is enabled.

Heat Pump fan status confirmed by current sensing device(s).

Fan operation: The supply fan runs continuously.

Room heating temperature setpoint nominal: 21.5 °C +/- 1.0 °C (adjustable)

Room Free Cooling Enabled temperature setpoint nominal 22.5 °C +/-1.0 °C

Room mechanical cooling temperature setpoint nominal 24.5 °C +/- 1.0 °C (adjustable)

3.19.6. Standby Occupancy Mode:

Time of day schedule starts the HVAC unit(s) usually between 4:00 p.m. and 11:00 p.m. Monday to Friday.

Minimum outdoor air is set to zero when the global ventilation schedule is off).

Fan operation: Supply fan and return fan (where applicable) runs only on a call from heating or cooling only.

Ventilation normally set to zero (with a future provision to adjust).

Room heating temperature setpoint nominal: 21.5 °C +/- 1.0 °C (adjustable)

Room Mechanical Cooling temperature setpoint nominal 24.5 °C +/- 1.0 °C (adjustable)

Free Cooling: Disabled

Global Ventilation Schedule: Disabled

3.19.7. Heating Sequence:

3.19.7.1. Outdoor Air Temperature used to determine Heating Enable Mode:

A set of thresholds that are user adjustable at a global (board wide) or local (site specific) level, triggers the heating enable mode based on the outdoor air temperature below the threshold. The threshold is further adjusted by a calendar schedule.

Typical default values are: 16 °C from September to May and 5 °C from June to August.

3.19.7.2. Default Setpoint:

When the Heating Mode is active, the default room temperature setpoint remains unchanged.

3.19.7.3. Call for Heating:

Heat pump is used for heating until the heating calls (from room controller PID or Night Setback thresholds) are satisfied.

Radiation Zone

Where there is a zone served by radiation, the radiation valve opens (where applicable) and is to be the second stage of heat.

3.19.8. Cooling Sequence:

3.19.8.1. Outdoor Air temperature used to determine cooling enable mode:

A set of thresholds that are user adjustable at a global (board wide) or local (site specific) level, triggers the cooling enable mode based on the outdoor air temperature exceeding the threshold. The threshold is further adjusted by a calendar schedule. Typical default values are: 18 °C from September to May and 21 °C from June to August.

3.19.8.2. Default Cooling Setpoint:

When the cooling enable mode is active, the default room temperature setpoint is raised by 3°C.

3.19.8.3. Call for Cooling:

When Free Cooling is available, and a demand for cooling is in place, free cooling as supplied by the associated Make Up Air Unit will be used first, and if the demand for cooling is still in place, mechanical cooling will be used until the cooling calls (from room controller PID) are satisfied.

3.19.9. Limits and Safeties:

3.19.9.1. The supply fan has a delay-off time of 90 seconds.

3.19.9.2. The DX cooling has a minimum-off time of 5 minutes.

- 3.19.10. Alarms:
An alarm will be generated upon the following conditions:
- 3.19.10.1. Fan status does not match the start/stop signal.
- 3.19.10.2. Space temperature too low alarm (triggered below 14 °C and restored above 16 °C).
- 3.19.10.3. Space temperature too high alarm (triggered above 38°C and restored above 36°C).
- 3.19.10.4. Supply air temperature too high alarm (triggered above 65 °C and restored below 63 °C) or too low alarm (triggered below 5 °C and restored above 7 °C).
- 3.19.10.5. Heat pump fault
- 3.19.10.6. Weekly fan runtime limit exceeded

3.20. Electric Heat Sequence of Operation (to be updated ?)

- 3.20.1. Stairwells and Vestibules:
- 3.20.1.1. Heating Disabled:
During Occupied Hours as set by the associated time schedule, heating is disabled when either the Outdoor Air Temperature above 12 °C or Vestibule Air Temperature above 18 °C are exceeded. During Unoccupied Hours as set by the associated time schedule, heating is disabled when either the Outdoor Air Temperature is above 5 °C or Vestibule Air Temperature is above 17 °C are exceeded.
- 3.20.1.2. Heating Enabled:
During Occupied Hours as set by the associated time schedule, heating is enabled when both the Outdoor Air Temperature below 10 °C and Vestibule Air Temperature above 16 °C. During Unoccupied Hours as set by the associated time schedule, heating is enabled when both the Outdoor Air Temperature below 0 °C and Vestibule Air Temperature below 16 °C.
- 3.20.1.3. Limits and Safeties:
 - 1) Vestibule heaters are disabled when outside temperature threshold(s) are exceeded.
 - 2) Vestibule heaters are disabled when room temperature threshold(s) are exceeded.
- 3.20.1.4. Alarms:
 - 1) Vestibule temperature too low or too high.
- 3.20.2. Utility Spaces: (add outdoor air temperature disable statement)
N.A MacEachern - room temperature sensor with single setpoint* no time schedule
Edna Staebler reference..
- 3.20.3. Supplemental Heat in Occupied Spaces (place in associated rooftop/air handler sequences) 2nd round item
E.g. Electric baseboard as second stage heat in offices

Fan Coil Units (Hydronic) (make this into its own standalone section)

From Conestogo

- 3.20.4. Unoccupied Mode
The system is off. If the pushbutton on the room sensor is pressed, the system will switch to the occupied mode for a period of 2 hours (adjustable).
- 3.20.5. Occupied Mode
Zone temperature sensor cycles the ductless split to maintain the occupied cooling setpoint. Setpoint adjustment of +/- 1 °C is provided.
- 3.20.6. Limits & Safeties
- 3.20.7. The unit is disabled when the outside air temperature is below the global mechanical cooling disable setpoint (initially disabled below 12 °C and enabled above 14 °C).
- 3.20.8. A minimum off-time of 5 minutes is provided.
- 3.20.9. The unit is sequenced with the associated VVT controls.
- 3.20.10. Alarms
An alarm is generated at the BAS if the zone temperature exceeds programmed alarm limits.

3.21. Electric? Force Flow Heater Sequence of Operations: (for vestibules and corridors? to be updated)

From Doon

- 3.21.1. Unoccupied Mode
Mode is active usually between 11:00 p.m. to 7:00 a.m. Monday to Friday and 24 hours Saturday and Sunday.

The system will be in Unoccupied Mode when not in Morning Warmup, Occupied or Standby modes. The system will cycle between Idle State, Heating State or Pushbutton Override States to meet the demands from each state and return to the Idle State when the demands are satisfied.

- 3.21.2. (Idle State)
The supply fan is off, heating is off.
- 3.21.2.1. (Heating State)
- 3.21.2.2. System cycles on a call for unoccupied heating. A full call for (full heat modulation where applicable) heating until setpoint is reached.
- 3.21.2.3. (Push Button Override State)
The system is off. If the pushbutton (where applicable) on the room sensor is pressed, the system will switch to the occupied mode for a period of 2 hours (adjustable).
- 3.21.3. Occupied Mode
- 3.21.4. Heating Sequence:
- 3.21.4.1. Outdoor Air Temperature used to determine Heating Enable Mode:
A set of thresholds that are user adjustable at a global (board wide) or local (site specific) level, triggers the heating enable mode based on the outdoor air temperature below the threshold. The threshold is further adjusted by a calendar schedule. Typical default values are: 16 °C from September to May and 5 °C from June to August.
- 3.21.4.2. Default Setpoint:
When the Heating Mode is active, the default room temperature setpoint remains unchanged.
- 3.21.4.3. Call for Heating:
Mechanical heating is used until the heating calls (from room controller PID or Night Setback thresholds) are satisfied.
- 3.21.5. Setpoint adjustment of +/- 1 °C is provided. (where applicable)
- 3.21.6. Limits & Safeties
- 3.21.6.1. **Heating is disabled when the outdoor air temperature is above the global heating disable setpoint (typically 2 °C above Heating Enable setpoint) or when the fan is off.**
- 3.21.7. A minimum off-time of 5 minutes is provided.
- 3.21.8. Alarms
An alarm will be generated upon the following conditions:
- 3.21.8.1. Space temperature too high alarm (triggered above 42 °C and restored below 40 °C).
- 3.21.8.2. Space temperature too low alarm (triggered below 14 °C and restored above 16 °C).

3.22. Exhaust Fan Sequence of Operations: (to be updated then ready for review)

- General and Washroom Exhaust Fans
- 3.22.1. Discretionary Fire Alarm Shutdown Mode:
The Exhaust Fan is off. This is not intended to replace the hard-wired fan shutdown provided by others when required by Code. Normal Exhaust Fan functions are auto restored on relay signal from the fire alarm panel reset.
- 3.22.2. Unoccupied Mode:
Mode is active usually between 11:00 p.m. to 7:00 a.m. Monday to Friday and 24 hours Saturday and Sunday.
The system will be in Unoccupied Mode when not in Occupied by modes.
- 3.22.2.1. (Idle State)
The exhaust fan is off.position.
- 3.22.3. Occupied Mode:
Time of day schedule, which starts the Exhaust Fan unit(s) usually between 7:00 a.m. and 4:00 p.m. Monday to Friday, when not overridden by a Holiday Schedule or Unoccupied Mode.
Exhaust Fan status confirmed by current sensing device(s) or VFD feedback.
Fan operation: The Exhaust Fan runs continuously.
- 3.22.4. Limits and Safeties:
- 3.22.4.1. The Exhaust fan has a delay-off time of 90 seconds.
- 3.22.4.2. The start times are staggered across a group of Exhaust Fans.
- 3.22.5. Alarms:
An alarm will be generated upon the following conditions:
- 3.22.5.1. Fan status does not match the start/stop signal.
- 3.22.5.2. Weekly fan runtime limit exceeded.

3.23. Science Prep / Classroom Fume Hood Sequence of Operations: (Coordinate w DBU for proper interlock)

3.23.1. Occupied Mode:

The BAS provides AUTO/ON control of the fume hood exhaust fan according to a time schedule.

Fan status is monitored by a current sensor.

When the fan status is on, the return air dampers close to a position as determined by the air balancer (mechanical stop).

3.23.2. Unoccupied Mode:

If the fume hood fan is running when the associated rooftop unit is off, the transfer damper opens to provide air to the room.

3.23.3. Limits and Safeties:

3.23.3.1. The Exhaust fan has a delay-off time of 90 seconds.

3.23.4. Alarms:

An alarm will be generated upon the following conditions:

3.23.4.1. Fan status does not match the start/stop signal.

3.23.4.2. Weekly fan runtime limit exceeded.

3.24. Kitchen Exhaust Hood Fan Sequence of Operations: (to be reviewed)

3.24.1. Occupied Mode:

The BAS provides AUTO/ON control of the Kitchen Exhaust hood fan according to a time schedule.

Fan status is monitored by a current sensor.

Where applicable, when the manually operated kitchen exhaust hood fan is on, the DX cooling (where applicable) on the associated fans are locked off. Free cooling will still operate if the outdoor conditions are favourable.

When the fan status is on, the return air dampers (where applicable) close to a position as determined by the air balancer (mechanical stop).

3.24.2. Unoccupied Mode:

Kitchen Exhaust Hood Fan is off.

3.24.3. Limits and Safeties:

3.24.3.1. The Exhaust fan has a delay-off time of 90 seconds.

3.24.4. Alarms:

An alarm will be generated upon the following conditions:

3.24.4.1. Fan status does not match the start/stop signal.

3.24.4.2. Weekly fan runtime limit exceeded.

3.25. Make Up Air Unit Sequence of Operations: (ready for review)

Woodland Park serves Fan Coils

3.25.1. Discretionary Fire Alarm Shutdown Mode:

The supply fan is off, the return fan is off (where applicable) and power exhaust fan is off (where applicable), the outdoor air dampers are in the 0% outdoor air position, heating is disabled and cooling (where applicable) is disabled. This is not intended to replace the hard-wired fan shutdown provided by others when required by Code. Normal HVAC unit functions are auto restored on relay signal from the fire alarm panel reset.

3.25.2. Software Freeze-stat Shutdown Mode:

The duct/unit mounted supply air temperature sensor acts as a software freeze-stat (triggered below 1 °C after 3 minutes, restored above 5 °C after 3 minutes, and auto reset after 5 minute delay).

3.25.3. Unoccupied Mode:

Mode is active usually between 11:00 p.m. to 7:00 a.m. Monday to Friday and 24 hours Saturday and Sunday.

The system will be in Unoccupied Mode when not in Morning Warmup, Occupied or Standby modes. The system will cycle between Idle State, Heating State or Pushbutton Override States to meet the demands from each state and return to the Idle State when the demands are satisfied.

3.25.3.1. (Idle State)

The supply fan is off, the return fan is off (where applicable) power exhaust fan is off (where applicable), the Global Ventilation Schedule is disabled, the outdoor air dampers are in the 0 % outdoor air position, heating is disabled and cooling (where applicable) is disabled.

3.25.3.2. (Heating State)

System cycles on a call for unoccupied heating. A full call for (all stages or full heat modulation where applicable) heating until setpoint is reached.

Heating temperature nominally 16.0 °C space temperature setpoint with an increased space temperature setpoint to 17.0 °C at -10.0 °C OAT or lower and 18.0 °C at -20.0 °C OAT or lower (each adjustable)

Mechanical Cooling: Disabled

Free Cooling: Disabled

Global Ventilation Schedule: Disabled

3.25.3.3. (Push Button Override State)

If the override pushbutton is pressed, at any room sensor, the associated system will switch to the Occupied Mode for 2 hours (adjustable). With outdoor air ventilation and cooling enabled.

3.25.4. Morning Warmup Mode:

An optimized start, based on the time of day schedule, outdoor air temperature and the lowest indoor zone temperature is provided for heating.

The Global Ventilation Schedule is disabled. The supply fan is on, the return fan is on (where applicable), the outdoor air mixing dampers are in the 0 % outdoor air position, heating is enabled at full capacity and the cooling is disabled.

The optimized start program is to begin up to 105 minutes before the occupancy schedule to allow for morning warm up to bring the lowest zone temperature up to occupancy setpoint.

3.25.5. Occupied Mode:

Time of day schedule, which starts the HVAC unit(s) along with an Optimum Start program usually between 7:00 a.m. and 4:00 p.m. Monday to Friday, when not overridden by a Holiday Schedule, Standby Occupancy Mode or Unoccupied Mode.

Global Ventilation Schedule is enabled.

HVAC unit fan status confirmed by current sensing device(s) or VFD feedback.

Fan operation: The supply fan and return fan (where applicable) run continuously.

Room heating temperature setpoint nominal: 21.5 °C +/- 1.0 °C (adjustable)

Room Free Cooling Enabled temperature setpoint nominal 22.5 °C +/-1.0 °C

Room mechanical cooling temperature setpoint nominal 24.5 °C +/- 1.0 °C (adjustable)

Global Ventilation Schedule: Enabled

3.25.6. Standby Occupancy Mode:

Time of day schedule starts the HVAC unit(s) usually between 4:00 p.m. and 11:00 p.m. Monday to Friday.

Minimum outdoor air is set to zero when the global ventilation schedule is off).

Fan operation: Supply fan and return fan (where applicable) runs only on a call from heating or cooling only.

Ventilation normally set to zero (with a future provision to adjust).

Room heating temperature setpoint nominal: 21.5 °C +/- 1.0 °C (adjustable)

Room Mechanical Cooling temperature setpoint nominal 24.5 °C +/- 1.0 °C (adjustable)

Free Cooling: Disabled

Global Ventilation Schedule: Disabled

3.25.7. Ventilation Lockout (Sequence):

When the ventilation lockout switch, usually located in the Custodial Office, is engaged, all outdoor air dampers close, free cooling is disabled, and the system switches to Standby Occupancy Mode of operation.

When the ventilation lockout switch is disengaged, systems return to mode of operation based on the time of day schedule.

3.25.8. Supply Air Temperature Setpoint:

The Supply Air Temperature Setpoint is reset between 13 °C to 18 °C as the outside air temperature falls from 10 °C to -15 °C.

The Supply Air Temperature Setpoint is limited to a range of 12 °C to 20 °C.

3.25.9. Heating Sequence:

3.25.9.1. Outdoor Air Temperature used to determine Heating Enable Mode:

A set of thresholds that are user adjustable at a global (board wide) or local (site specific) level, triggers the heating enable mode based on the outdoor air temperature below the threshold. The threshold is further adjusted by a calendar schedule.

Typical default values are: 16 °C from September to May and 5 °C from June to August.

3.25.9.2. Default Setpoint:

When the Heating Mode is active, the default room temperature setpoint remains unchanged.

Make Up Air Unit cooling is controlled from the supply air temperature sensor.

3.25.9.3. Call for Heating:

Mechanical heating is used until the heating calls (from supply air temperature controller PID or Night Setback thresholds) are satisfied.

Hydronic

For Heating Valve, (where applicable) 0 % signal (10 Volts) closes the heating valve. A 100% signal (below 2 Volts) opens the heating valve.

Radiation Zone

Where there is a zone served by radiation, the radiation valve opens (where applicable) and is to be substituted as the first stage of heating.

3.25.10. Cooling Sequence:

3.25.10.1. Outdoor Air temperature used to determine cooling enable mode:

A set of thresholds that are user adjustable at a global (board wide) or local (site specific) level, triggers the cooling enable mode based on the outdoor air temperature exceeding the threshold. The threshold is further adjusted by a calendar schedule. Typical default values are: 18 °C from September to May and 21 °C from June to August.

3.25.10.2. Default Cooling Setpoint:

When the cooling enable mode is active, the default room temperature setpoint is raised by 3 °C, for all associated Heat Pumps. Make Up Air Unit cooling is controlled from the supply air temperature sensor.

3.25.10.3. Call for Cooling:

When Free Cooling is available, and a demand for cooling is in place, free cooling will be used first, and if the demand for cooling is still in place, mechanical cooling will be used until the cooling calls (from supply air temperature controller PID) are satisfied.

3.25.11. Limits and Safeties:

3.25.11.1. The duct mounted supply air temperature sensor acts as a high limit for each stage of heating (for stage 1: disable above 60°C , and enable below 50°C, for stage 2: disable above 55°C and enable below 45°C) and a low limit for each stage of cooling (for stage 1: disable DX1 below 5°C and enable DX1 above 10 °C, for stage 2: below 8 °C disable DX2 and above 13°C enable DX2).

3.25.11.2. The supply air temperature sensor acts as a software freezestat (triggered below 1 °C for 1 minute, restored above 5 °C for 1 minute), auto reset after 5 minute delay.

3.25.11.3. The supply fan has a delay-off time of 90 seconds.

3.25.11.4. The DX cooling has a minimum-off time of 5 minutes.

3.25.11.5. DX cooling is disabled when the outdoor air temperature is below global DX disable setpoint (typically 2 °C below Cooling Enable setpoint) or when fan is off.

3.25.11.6. Gas heating is disabled when the outdoor air temperature is above the global heating disable setpoint (typically 2 °C above Heating Enable setpoint) or when the fan is off.

3.25.11.7. Stage 1 gas heating (where applicable for units with multiple stages of heating) has a minimum run time of 3 minutes.

3.25.11.8. The default zone setpoint is increased by 3°C when mechanical cooling is enabled (providing heating is disabled). The standard mechanical cooling setpoint will be limited to a (minimum of 23.5 °C - adjustable).

3.25.11.9. When the ventilation lockout switch (usually located at the custodial office) is engaged, the outdoor air dampers close, free cooling is disabled, and the system switches to Standby Occupancy Mode.

3.25.11.10. Minimum outdoor air is provided when enabled by the Global Ventilation Schedule.

3.25.11.11. Cooling cannot turn on until heating has been off for a minimum of 5 minutes.

3.25.11.12. During Occupied Mode, and the outdoor air is above -1°C, heating stage 2 (where applicable) has a delay-on time of 15 minutes, except when the outdoor air temperature is below -3°C with a +2°C deadband.

3.25.11.13. Minimum outdoor air is set to zero when the Global Ventilation Schedule is off.

3.25.12. Alarms:

An alarm will be generated upon the following conditions:

3.25.12.1. Fan status does not match the start/stop signal.

3.25.12.2. Supply air temperature too high alarm (triggered above 65 °C and restored below 63 °C) or too low alarm (triggered below 5 °C and restored above 7 °C).

3.25.12.3. Space temperature too high alarm (triggered above 42 °C and restored below 40 °C) for non-cooling systems, (triggered above 38°C and restored above 36°C) for cooling systems.

3.25.12.4. Space temperature too low alarm (triggered below 14 °C and restored above 16 °C).

3.25.12.5. Weekly fan runtime limit exceeded.

3.25.12.6. Software freezestat tripped.

3.26. Furnace Sequence of Operation: (ready to review)

Serving internal spaces like gym storage rooms. Uses return air only, no outside air ductwork. No supply air sensor. BAS enables fan and gas burner through built-in Furnace controller.

3.26.1. Discretionary Fire Alarm Shutdown Mode:

The supply fan is off, heating is disabled. This is not intended to replace the hard-wired fan shutdown provided by others when required by Code. Normal Furnace unit functions are auto restored on relay signal from the fire alarm panel reset.

3.26.2. Unoccupied Mode:

Mode is active usually between 11:00 p.m. to 7:00 a.m. Monday to Friday and 24 hours Saturday and Sunday.

The system will be in Unoccupied Mode when not in Morning Warmup, Occupied or Standby modes. The system will cycle between Idle State, Heating State or Pushbutton Override States to meet the demands from each state and return to the Idle State when the demands are satisfied.

3.26.2.1. (Idle State)

The supply fan is off, the return fan is off (where applicable) power exhaust fan is off (where applicable), the Global Ventilation Schedule is disabled, the outdoor air mixing dampers are in the 0 % outdoor air position, heating is disabled and cooling is disabled. The bypass damper is in the 100 % open position. The zone dampers are in the 50 % open position.

3.26.2.2. (Heating State)

System cycles on a call for unoccupied heating. A full call for (all stages or full heat modulation where applicable) heating until setpoint is reached.

Heating temperature nominally 16.0 °C space temperature setpoint with an increased space temperature setpoint to 17.0 °C at -10.0 °C OAT or lower and 18.0 °C at -20.0 °C OAT or lower (each adjustable)

3.26.3. (Push Button Override State)

If the override pushbutton (where applicable) is pressed, at any room sensor, the associated system will switch to the Occupied Mode for 2 hours (adjustable). With outdoor air ventilation and cooling enabled.

3.26.4. Occupied Mode:

Time of day schedule, which starts the HVAC unit(s) along with an Optimum Start program usually between 7:00 a.m. and 4:00 p.m. Monday to Friday, when not overridden by a Holiday Schedule, Standby Occupancy Mode or Unoccupied Mode.

Furnace unit fan status confirmed by current sensing device(s) or VFD feedback.

Fan operation: The supply fan runs continuously.

Room heating temperature setpoint nominal: 19 °C +/- 1.0 °C (adjustable)

3.26.5. Standby Occupancy Mode:

Time of day schedule starts the HVAC unit(s) usually between 4:00 p.m. and 11:00 p.m. Monday to Friday.

Minimum outdoor air is set to zero when the global ventilation schedule is off).

Fan operation: Supply fan and return fan (where applicable) runs only on a call from heating or cooling only.

Ventilation normally set to zero (with a future provision to adjust).

Room heating temperature setpoint nominal: 18 °C +/- 1.0 °C (adjustable)

3.26.6. Heating Sequence:

3.26.6.1. Outdoor Air Temperature used to determine Heating Enable Mode:

If the outdoor air temperature is above 10 °C the unit is disabled.

3.26.6.2. Default Setpoint:

When the Heating Mode is active, the default room temperature setpoint remains unchanged.

3.26.6.3. Call for Heating:

Mechanical heating (single stage gas heating) is used until the heating calls (from room controller PID or Night Setback thresholds) are satisfied.

Radiation Zone

Where there is a zone served by radiation, the radiation valve opens (where applicable) and is to be substituted as the first stage of heating.

3.26.7. Limits and Safeties:

3.26.7.1. The supply fan has a delay-off time of 90 seconds.

3.26.7.2. Stage 1 gas heating (where applicable for units with multiple stages of heating) has a minimum run time of 3 minutes.

3.26.8. Alarms:

An alarm will be generated upon the following conditions:

3.26.8.1. Fan status does not match the start/stop signal.

3.26.8.2. Space temperature too high alarm (triggered above 42 °C and restored below 40 °C) for non-cooling systems, (triggered above 38°C and restored above 36°C) for cooling systems.

3.26.8.3. Space temperature too low alarm (triggered below 14 °C and restored above 16 °C).

3.26.8.4. Weekly fan runtime limit exceeded.

3.27. Destratification Fans Sequence of Operation: (Library/Gyms/Atrium)

Destratification Fans to be controlled by integral controls provided with fan packages (no BAS controls are anticipated).

3.28. Exterior Lighting Sequence of Operation:

3.28.1. Exterior Building Lights

The lights operate according to the time schedule. Lights are disabled between sunrise and sunset, as calculated by a software astronomical timer. The following astronomical clock program for exterior lighting is in effect 7 days a week, at all schools, with the exception of schools with vandalism concerns.

September – June: On: 5:45 a.m. Off: At Dawn On: At Dusk Off: 11:45 p.m.

July and August: Exterior Lights Off

3.28.2. Parking Lot Lights

Where applicable, parking lot lighting should be zoned and scheduled separately from exterior building lighting. The lights operate according to the time schedule. Lights are disabled between sunrise and sunset, as calculated by a software astronomical timer. The following astronomical clock program for exterior lighting is in effect 7 days a week, at all schools, with the exception of schools with vandalism concerns.

September – June: On: 5:45 a.m. Off: At Dawn On: At Dusk Off: 11:45 p.m.

July and August: Exterior Lights Off

3.28.3. Exterior School Sign

Controlled by integral controls provided with school sign packages (no BAS controls are anticipated)

3.29. Domestic Hot Water Recirc Pump (only enable/disable based on time of day schedule for secondary schools - elementary to use stand alone time/aquastat provided by others)

3.30. Low Temperature Alarm Sequence of Operation (ready for review)

3.31. Space Temperature

If any space temperature falls below 14 °C (adjustable), after 30 minutes, a local "heat loss" alarm will be activated through the security system.

When adding new zones to an existing school, integration of the new zone's lowest space temperature is to be sent in from the new BAS system over to the existing BAS system via software or hardware point tied-in from the new BAS system to the existing BAS system. The original BAS system will have to have its software updated to accommodate the new heat loss point.

3.32. Hot Water Heating Supply Water Temperature

If the hot water heating supply water temperature is more than 15 °C (adjustable) below the setpoint or falls below 45 °C, a critical alarm will be activated through the security system. An alarm will also be generated at the BAS. The alarm will be disabled between April 15 and October 15, which is when heating systems are typically allowed to shut down based on outdoor air temperature heating enable setpoint.

3.33. Free Cooling Setpoint Sequence of Operation

The average outdoor air relative humidity is sent from the Vista Server to the Global Input for all schools where the Free Cooling Setpoint is calculated.

Free cool when $OAT < \text{minimum} (23\text{ }^{\circ}\text{C}, 29.4\text{ }^{\circ}\text{C} - \Phi/7.43)$ where Φ is the average relative humidity in %RH.

The free cooling signal is 100 % when the outdoor air temperature is more than 2 °C less than the free cooling setpoint.

The free cooling signal decreases towards zero linearly as the outdoor air temperature increases from 2 °C less than the free cooling setpoint to 0 % at the setpoint.

This free cooling signal is used in each mixed air damper controller as the maximum the outdoor air dampers can open.

Minimum outdoor air damper position signal may exceed the free cooling signal.

The free cooling signal is still subject to the mixed damper safeties that would keep minimum position during occupied mode.

Also the free cooling signal will be at a lower priority than the CO₂ demand ventilation (where applicable) up to 40 % outside damper position.

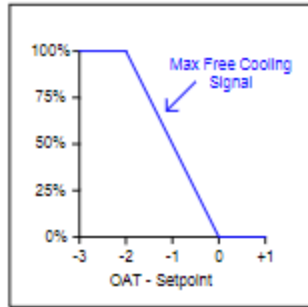

Detail 1

3.34. **Miscellaneous Monitoring (ready for review)**

3.34.1. Sump Pump Level Alarm (not by BAS)

3.34.2. VFD Drive Fault

Provide a dry contact input to sense if VFD drive is in fault mode.
Produce an alarm at the BAS.

3.34.3. Boiler Fault

Provide a dry contact input to sense if Boiler is in fault mode.
Produce an alarm at the BAS.

3.34.4. Chiller Fault

Provide a dry contact input to sense if Chiller is in fault mode.
Produce an alarm at the BAS.

3.34.5. Rooftop Unit Fault

Provide a dry contact input to sense if the Rooftop Unit (where applicable) is in fault mode.
Produce an alarm at the BAS.

3.35. **Energy Conservation Measures**

3.35.1. Demand Limiting Control

Energy conservation measure to strategically curtail the use of certain equipment (i.e. chillers, VFD drives) in order to not trigger excess electricity demands at peak load times.

3.35.2. Orderly Shutdown

Energy conservation measure to strategically curtail the runtime of stages of heating and cooling by a variable amount of time before the end of occupancy.

3.35.3. Weekly fan runtime monitoring

A monitoring tool to track the amount of Fan Runtime on a weekly basis. A report quickly identifies the fans that ran an excessive amount of time.

3.35.4. Trend generation

Trends Logs are collected at the BAS server level for charting and exporting for analysis.

3.35.5. Trend Archival operations

Export logs and charts for future reference.

3.35.6. Trend Data Analysis Support

Trends Logs are collected at the BAS server level for charting and exporting for analysis.

3.35.7. Reporting Requirements

Keep consistent point naming conventions to allow for searches of logs and trends into reports across a system, site and multiple sites.

3.36. **Setpoints and Schedule Standards (ready for review)**

3.36.1. Default Occupied Room Heating Setpoint

Typically 21 °C.

3.36.2. Default Occupied Room Cooling Setpoint

Typically +3 °C above Default Occupied Room Heating Setpoint, limited to a minimum of 23.5 °C.

- 3.36.3. Default Standby Room Heating Setpoint
Typically 20 °C.
- 3.36.4. Default Standby Room Cooling Setpoint
Typically +3 °C above Default Occupied Room Heating Setpoint, limited to a minimum of 23.5 °C.
- 3.36.5. Default Unoccupied Room Heating Setpoint
Typically 19 °C.
- 3.36.6. Default Unoccupied Room Cooling Setpoint
Not used at WRDSB. (No mechanical cooling during unoccupied hours).
- 3.36.7. Default Gym Occupied Room Heating Setpoint
Typically 19 °C.
- 3.36.8. Default Occupied Schedule
Typically 6 a.m. to 6 p.m. Monday to Friday.
- 3.36.9. Default Standby Schedule
Typically 6 p.m. to 11 p.m.
- 3.36.10. Holiday Calendar Schedule
Board Holidays:
January 1st - New Year's Day
Family Day - Varies
March Break - Varies
July 1st - Canada Day
Labour Day - Varies
Thanksgiving - Varies
Winter Break - Varies
December 25 - Christmas Day
December 26 - Boxing Day

3.37. Alarm Handling

Alarms in Xenta are generated and pushed into the BAS.
Alarms in Distech can be programmed into the EC-BOS (JACE 8000) as a point extension and reported to the EC-BOS alarm console.

3.38. Outside Air Temperature

Located on the north face of the building with a sun and wind shield.
Wired to a dedicated input, typically on a boiler controller (where applicable) or a master BAS controller and is shared across the BAS network to all the controllers in the building.
Used to reset setpoints and to enable/disable equipment for energy savings.

3.39. Outside Air Humidity

Located on the north face of the building with a sun and wind shield.
Wired to a dedicated input, typically on a rooftop controller (where applicable) or a master BAS controller and is shared across the BAS network to all the controllers in the building.
Used to restrict free cooling if outdoor air conditions are not appropriate.

3.40. Carbon Dioxide

Located in the return air duct or room sensor.
Used to reset the minimum damper position.

3.41. Static Pressure

Located in the supply air duct typically in VAV and VVT systems.
Used to control system pressure via the bypass damper for VVT or VFD fan speed in VAV systems.

3.42. Graphics

- 3.42.1. Navigation
Central menu displaying all systems made available with hyperlinks.
- 3.42.2. Structure
Points folders are grouped under their physical controllers.
System folders containing the relevant points are grouped together.
- 3.42.3. Symbols
Two dimensional symbols and line based ductwork and piping diagrams.

- 3.42.4. Colours
 Green text for user adjustable setpoints
 Magenta text for calculated setpoints
 Black text for sensors, statuses, inputs in general.
 Red text for binary output commands in the Stop state.
 Green text for binary output commands in the Start state.
 Black text for analog control points like valves and dampers.
 - 3.42.5. Legend
 Indicate the meaning of the text colours.
 - 3.42.6. Floor Plan
 Scan from architectural drawings, simplify and format to convey the building envelope and room locations with current room names.
 Zone temperatures with colour coded inks to zones and systems from the graphic.
 - 3.42.7. Systems
 Two dimensional symbols and line based ductwork and piping diagrams.
 Access to setpoints and schedules.
 - 3.42.8. Setpoint
 Green text for user adjustable setpoints
 Magenta text for calculated setpoints
 - 3.42.9. Levels of Access
 Casual user: read only
 Technical user: read/write access to setpoints and schedules, override access to points.
- 3.43. Security**
- 3.43.1. Levels of Access
 Casual user: read only
 Technical user: read/write access to setpoints and schedules, override access to points.

4. Appendix:

4.1. Appendix A: Humidity-Limited Free Cooling Table

| OAH | | FreeClgSp | | OAT | | Difference | | FreeClgMax | |
|-----|-----|-----------|----|-----|----|------------|----|------------|-----|
| 85 | %RH | 17.96 | °C | 0 | °C | -2 | °C | 100 | %OA |
| 99 | %RH | 16.08 | °C | 0 | °C | -2 | °C | 100 | %OA |
| 45 | %RH | 23.34 | °C | 0 | °C | -2 | °C | 100 | %OA |
| 60 | %RH | 21.32 | °C | 10 | °C | -2 | °C | 100 | %OA |
| 70 | %RH | 19.98 | °C | 11 | °C | -2 | °C | 100 | %OA |
| 80 | %RH | 18.63 | °C | 12 | °C | -2 | °C | 100 | %OA |
| 60 | %RH | 21.32 | °C | 13 | °C | -2 | °C | 100 | %OA |
| 100 | %RH | 15.94 | °C | 13 | °C | -2 | °C | 100 | %OA |
| 95 | %RH | 16.61 | °C | 14 | °C | -2 | °C | 100 | %OA |
| 100 | %RH | 15.94 | °C | 14 | °C | -1.94 | °C | 97.05 | %OA |
| 85 | %RH | 17.96 | °C | 15 | °C | -2 | °C | 100 | %OA |
| 95 | %RH | 16.61 | °C | 15 | °C | -1.61 | °C | 80.7 | %OA |
| 100 | %RH | 15.94 | °C | 15 | °C | -0.94 | °C | 47.05 | %OA |
| 80 | %RH | 18.63 | °C | 16 | °C | -2 | °C | 100 | %OA |

| OAH | | FreeClgSp | | OAT | | Difference | | FreeClgMax | |
|--|-----|---|-----|--|----|------------|----|------------|-----|
| 85 | %RH | 17.96 | °C | 16 | °C | -1.96 | °C | 97.99 | %OA |
| 90 | %RH | 17.29 | °C | 16 | °C | -1.29 | °C | 64.35 | %OA |
| 95 | %RH | 16.61 | °C | 16 | °C | -0.61 | °C | 30.7 | %OA |
| 100 | %RH | 15.94 | °C | 16 | °C | 0 | °C | 0 | %OA |
| 70 | %RH | 19.98 | °C | 17 | °C | -2 | °C | 100 | %OA |
| 80 | %RH | 18.63 | °C | 17 | °C | -1.63 | °C | 81.64 | %OA |
| 90 | %RH | 17.29 | °C | 17 | °C | -0.29 | °C | 14.35 | %OA |
| 70 | %RH | 19.98 | °C | 18 | °C | -1.98 | °C | 98.94 | %OA |
| 80 | %RH | 18.63 | °C | 18 | °C | -0.63 | °C | 31.64 | %OA |
| 90 | %RH | 17.29 | °C | 18 | °C | 0 | °C | 0 | %OA |
| 70 | %RH | 19.98 | °C | 19 | °C | -0.98 | °C | 48.94 | %OA |
| 80 | %RH | 18.63 | °C | 19 | °C | 0 | °C | 0 | %OA |
| 90 | %RH | 17.29 | °C | 19 | °C | 0 | °C | 0 | %OA |
| 70 | %RH | 19.98 | °C | 20 | °C | 0 | °C | 0 | %OA |
| 80 | %RH | 18.63 | °C | 20 | °C | 0 | °C | 0 | %OA |
| 90 | %RH | 17.29 | °C | 20 | °C | 0 | °C | 0 | %OA |
| 70 | %RH | 19.98 | °C | 21 | °C | 0 | °C | 0 | %OA |
| 80 | %RH | 18.63 | °C | 21 | °C | 0 | °C | 0 | %OA |
| 90 | %RH | 17.29 | °C | 21 | °C | 0 | °C | 0 | %OA |
| 70 | %RH | 19.98 | °C | 22 | °C | 0 | °C | 0 | %OA |
| 80 | %RH | 18.63 | °C | 22 | °C | 0 | °C | 0 | %OA |
| | | | | | | | | | |
| Inputs - Difference Limited to 0 and -2 °C | | | | Outputs - Limited to 0 to 100 %OA | | | | | |
| Inputs Difference= FreeClgSp-OAT (°C) | | Outputs %Outside Air Damper Position (%OA) | | | | | | | |
| -2 | °C | 100 | %OA | | | | | | |
| 0 | °C | 0 | %OA | | | | | | |

4.2. **Appendix B: Outside Air Temperature Limited Free Cooling Table**

| Outside Air Temperature (OAT) | | Outside Air Temperature Limited (OAT Limited) | | Final Damper Position High Limit (OatLL) | |
|-------------------------------|----|---|----|--|-----|
| -30 | °C | -20 | °C | 0 | %OA |
| -25 | °C | -20 | °C | 0 | %OA |
| -20 | °C | -20 | °C | 0 | %OA |
| -19 | °C | -19 | °C | 3.33 | %OA |
| -18 | °C | -18 | °C | 6.67 | %OA |
| -17 | °C | -17 | °C | 10 | %OA |
| -16 | °C | -16 | °C | 13.33 | %OA |
| -15 | °C | -15 | °C | 16.67 | %OA |
| -14 | °C | -14 | °C | 20 | %OA |
| -13 | °C | -13 | °C | 23.33 | %OA |
| -12 | °C | -12 | °C | 26.67 | %OA |
| -11 | °C | -11 | °C | 30 | %OA |
| -10 | °C | -10 | °C | 33.33 | %OA |
| -9 | °C | -9 | °C | 36.67 | %OA |
| -8 | °C | -8 | °C | 40 | %OA |
| -7 | °C | -7 | °C | 43.33 | %OA |
| -6 | °C | -6 | °C | 46.67 | %OA |
| -5 | °C | -5 | °C | 50 | %OA |
| -4 | °C | -4 | °C | 53.33 | %OA |
| -3 | °C | -3 | °C | 56.67 | %OA |
| -2 | °C | -2 | °C | 60 | %OA |
| -1 | °C | -1 | °C | 63.33 | %OA |
| 0 | °C | 0 | °C | 66.67 | %OA |
| 1 | °C | 1 | °C | 70 | %OA |
| 2 | °C | 2 | °C | 73.33 | %OA |
| 3 | °C | 3 | °C | 76.67 | %OA |
| 4 | °C | 4 | °C | 80 | %OA |
| 5 | °C | 5 | °C | 83.33 | %OA |
| 6 | °C | 6 | °C | 86.67 | %OA |
| 7 | °C | 7 | °C | 90 | %OA |
| 8 | °C | 8 | °C | 93.33 | %OA |
| 9 | °C | 9 | °C | 96.67 | %OA |
| 10 | °C | 10 | °C | 100 | %OA |

| Outside Air Temperature (OAT) | | Outside Air Temperature Limited (OAT Limited) | | Final Damper Position High Limit (OatLL) | |
|-------------------------------|----|---|----|--|-------|
| 20 | °C | 10 | °C | 100 | %OA |
| 25 | °C | 10 | °C | 100 | %OA |
| | | | | | |
| | | | | Oat | OatLL |
| | | | | -20 | 0 |
| | | | | 10 | 100 |

4.3.

5. Reference Section:

5.1. Cooling Tower from Jacob Hespler

From the original spec: Part 4 Sequence of Operation

4.1 GENERAL

All setpoints shall be adjustable.

Outdoor air temperature shall be broadcasted to all controllers.

Heating mode: Heating is enabled between October 15 and April 15 or if the outdoor air temperature is below 10°C. This heating mode is used in all controllers for the building.

Cooling Mode: Mechanical cooling is enabled if the outdoor air temperature is above 18°C.

Occupancy mode shall be determined by a weekly schedule with an annual holiday schedule. Each system shall have this schedule but there shall be provision for operating under a general (to the building) schedule as well. An adjustable parameter shall be available to select the local or general schedule for each system.

Jacob Hespeler SS Cooling Tower Replacements Section 25 40 11 TENDER #22-7280-RFT Building Controls System

Lead/lag: Devices designed for lead lag operation shall operate in automatic lead/lag mode to equalize run time. If the lead unit fails the lag shall automatically start and an alarm shall be generated. The lead unit shall be advanced through the series of devices in sequence every Tuesday at noon.

EQUIPMENT SERVICES Graphical sequence of operations will be provided by BAS contractor.

5.2. Gym Unit from Groh

Gym Unit SEQUENCE OF OPERATION

Unoccupied Mode

The supply fan is off, the mixing dampers are in the 0% outside air position and the heating is off. The fan cycles on a call for unoccupied heating or cooling. If the override pushbutton is pressed, the system will switch to the occupied mode for 2 hours (adjustable).

Occupied Mode

An optimized start routine is provided for heating. During morning warm-up the outside air minimum position is set to zero. The supply fan runs

continuously. The room temperature sensor modulates heating (resets the setpoint of the discharge air controller) in sequence with the mixing dampers

(for free cooling) to maintain setpoint. Local setpoint adjust (+/-2°C) is provided.

The gym partition position switch indicates whether the dividing wall is open or closed. If the wall is open, the two rooftop units control to an average

room temperature setpoint. If the wall is closed, the two rooftop units operate autonomously.

Limits & Safeties

1) If the outside air temperature exceeds the free cooling setpoint, the mixing dampers return to minimum outside air position.

2) The maximum amount of outside air is limited based on the outside air temperature to prevent excessively low supply air temperatures during startup.

3) Mixed air temperature sensor acts as a low limit to ensure temperature does not fall below setpoint.

4) The supply air temperature sensor acts as a software freeze stat and will shut down the system if the temperature falls below 2/5°C (auto reset, 3 minute delay before shutdown, 5 minute delay before reset).

7) The supply air temperature sensor acts as a high limit, and will shut down heating if the temperature exceeds 55°C.

8) The CO2 sensor acts as a high limit, and will increase the amount of minimum outside air as the space CO2 increases from 1000 to 1200 ppm.

9) The outside air dampers close when ventilation lockout is engaged.

Alarms

An alarm will be generated upon the following conditions:

- 1) Fan status does not match start/stop signal.
- 2) Supply air temperature too high (60/58°C) or too low (7/9°C).
- 3) Space temperature too high (38/36°C) or too low (14/15°C).
- 4) Mixed air temperature too high (50/48°C) or too low (5/7°C).
- 5) Return air temperature too high (42/40°C) or too low (14/15°C).
- 6) Supply fan weekly runtime has exceeded runtime setpoint.
- 7) Software freeze/stop tripped.
- 8) CO₂ too high (1700/1650 ppm) or too low (250/300 ppm).

5.3. Gym Units from Millen Woods

From Millen Woods (Gym Supply Fans):

SEQUENCE OF OPERATION

Unoccupied Mode The supply fan is off, the mixing dampers are in the 100% recirculation position, the heating is off. The fan cycles on a call for unoccupied heating or cooling. If the override pushbutton is pressed, the system will switch to the occupied mode for 2 hours (adjustable).

Occupied Mode An optimized start routine is provided for heating. During morning warm-up the outside air minimum position is set to zero. The supply fan runs continuously. The room temperature sensor modulates heating (resets the setpoint of the discharge air controller) in sequence with the mixing dampers (for free cooling) to maintain setpoint. Local setpoint adjust (+/-2°C) is provided. The minimum outdoor air setting is 10% open. When the return air CO₂ levels increase between 800 and 1200 ppm the minimum outdoor air setting increases between 10 and 100% but this is further reset closed in extreme outdoor air temperatures below -18°C and above 29°C. The CO₂ readings are automatically trended.

Exhaust Fan Speed Control The exhaust fan speed is controlled on all units in unison to maintain the internal building pressure between -20 and +20 Pa as measured between the Second Floor return air ceiling plenum and Exterior Storage 176.

Limits & Safeties

- 1) If the outside air temperature exceeds the return air temperature, the mixing dampers return to minimum outside air position.
- 2) The maximum amount of outside air is limited based on the outside air temperature to prevent excessively low supply air temperatures during startup.
- 3) Mixed air temperature sensor acts as a low limit to ensure temperature does not fall below setpoint.
- 4) The unit has blower delay-on and delay-off timers.
- 5) The supply air temperature sensor acts as a software freeze/stop (-1/ 5°C), 3 minute delay, auto reset after 5 minute delay.
- 6) The supply air temperature sensor acts as a high limit for heating (70/ 55°C).

Alarms An alarm will be generated upon the following conditions:

- 1) Fan status does not match the start/ stop signal.
- 2) Supply air temperature too high (65/ 55°C) or too low (1/ 5°C).
- 3) Space temperature too high (38/ 36°C) or too low (14/ 15°C).
- 4) Mixed air temperature too high (38/ 36°C) or too low (1/ 4°C).
- 5) Return air temperature too high (38/ 36°C) or too low (14/ 15°C).
- 6) Fan run time exceeded.
- 7) Return air CO₂ too high (1800/ 1700 ppm) or too low (200/ 250 ppm).
- 8) Supply air freeze/stop tripped.
- 9) Heating fault.

5.4. Gym Units from Edna Staebler

Edna Staebler (Gym Units 2015)

SEQUENCE OF OPERATION **Unoccupied Mode** The supply fan is off, the mixing dampers are in the 100% recirculation position, the heating is off. The fan cycles on a call for unoccupied heating or cooling. If the override pushbutton is pressed, the system will switch to the occupied mode for 2 hours (adjustable). **Occupied Mode** An optimized start routine is provided for heating. During morning warm-up the outside air minimum position is set to zero. The supply fan runs continuously. The room temperature sensor modulates heating (resets the setpoint of the discharge air controller) in sequence with the mixing dampers (for free cooling) to maintain setpoint. Local setpoint adjust (+/-2°C) is provided. The minimum outdoor air setting is 20% open. When the return air carbon dioxide levels increase between 800 and 1600 ppm the minimum outdoor air setting increases between 20 and 100% but this is further reset closed in extreme outdoor air temperatures below -15°C and above 30°C. The carbon dioxide readings are automatically logged. The power exhaust fan runs when the outside air damper is more than 50% open (local hard-wired controls).

Limits & Safeties 1) If the outside air temperature exceeds the return air temperature, the mixing dampers return to minimum outside air position. 2) The maximum amount of outside air is limited based on the outside air temperature to prevent excessively low supply air temperatures during startup. 3) Mixed air temperature sensor acts as a low limit to ensure temperature does not fall below setpoint. 4) The unit has a blower delay-on timer. 5) The supply air temperature sensor acts as a software freeze/stop (-1/

5°C), 3 minute delay, auto reset after 5 minute delay. Alarms An alarm will be generated upon the following conditions: 1) Fan status does not match start/ stop signal. 2) Supply air temperature too high (65/ 55°C) or too low (1/ 5°C). 3) Space temperature too high (38/ 36°C) or too low (14/ 15°C). 4) Mixed air temperature too high (38/ 36°C) or too low (1/ 4°C). 5) Return air temperature too high (38/ 36°C) or too low (14/ 15°C). 6) Fan run time exceeded. 7) Return air CO2 too high (1800/ 1700 ppm) or too low (200/ 250 ppm). 8) Supply air freezestat tripped. 9) Heating fault.

5.5. Unit Ventilators (referenced from Crestview, Laurentian, Doon, Conestogo)

Unit Vents (Galt, Doon)

Galt

Sequence of Operation

Unoccupied Mode

The fan is off, the mixing dampers are in the 0% outdoor air position, the heating valve is open, the DX cooling is off and the face & bypass damper is in the face position. The rad valve modulates (as first stage heating) and the fan cycles (as second stage heating) to maintain the unoccupied heating setpoint. If

the pushbutton on the room sensor is pressed, the system returns to the occupied mode for a period of two hours.

Occupied Mode

An optimized start routine for heating calculates the system occupancy time for heating. The fan runs continuously. Fan status is monitored by a current

sensor. The room temperature sensor controls the mixing dampers (for free cooling), face and bypass dampers (for heating), coil heating valve and

convector valve in sequence to maintain the heating setpoint; and DX cooling to maintain the cooling setpoint. The setpoint can be adjusted +/-2°C at the

room sensor.

Limits and Safeties

The supply air temperature sensor acts as a low limit to open the face and by-pass damper as required to maintain setpoint which is reset from outside air temperature.

Mixed air damper minimum position control is provided during occupied periods (initially 10% OA).

The outdoor air damper position for UV-1 is increased when Kitchen exhaust fan EF-5 is running.

If the outside air temperature exceeds the free cooling setpoint based on networked outdoor humidity, the mixing dampers return to minimum position.

The mixed air temperature sensor modulates the outdoor air dampers as a low limit to ensure temperature does not fall below setpoint.

If the hot water heating supply water temperature is below 40°C and the OAT is below 2°C, the UV turns off.

If the freezestat trips, the fan shuts down, OAD closes, F&BP damper goes to bypass, the heating valve opens and an alarm is generated at the BAS.

When the outside air temperature is below 3°C, the heating valve is fully open.

The supply air temperature sensor acts as a software freezestat, and will shut down the system if the temperature falls below 3/5°C for more than 1

minute (5 minute delay on auto-reset).

The CO2 sensor will increase the amount of minimum outside air from minimum to 40% as the CO2 level increases from 1000 ppm to 1200 ppm.

The supply fan has a delay-off time of 90 seconds.

When DX cooling is on than face & bypass damper is fully open to the coils.

DX cooling has a minimum-off time of 5 minutes and cannot run until the heating has been off for at least 30 minutes.

DX cooling is disabled when the outside air temperature is below the global DX disable setpoint or when the fan is off.

Alarms

An alarm is indicated at the operator's terminal if any of the following occur:

Fan status does not match fan start/stop signal.

Room temperature too low (14/15°C) or too high (35/34°C).

Supply air

temperature too low (5/8°C) or too high (65/62°C).

Software freezestat tripped.

CO2 too high (1700/1650 ppm) or too low (250/300 ppm).

Doon

SEQUENCE OF OPERATION

Note: Control wiring between indoor unit and outdoor condensing unit by controls contractor.

NOTES:

Supply air temperature sensor, FBD actuator, OAD actuator, and freeze-stat supplied with UV (digital ready)

Unoccupied Mode

The fan is off, the heating valve is open, the face & bypass damper is in the face position, the DX cooling is off and the mixing dampers are in the 0% outside air position. The fan cycles with full heating to maintain the unoccupied heating setpoint (initially 17.5°C).

If the pushbutton on the room sensor is pressed, the system will revert to occupied mode for a period of 2 hours.

Occupied Mode

An optimized start routine for heating advances the system start time when morning warm-up is required. The fan runs continuously to maintain temperature and CO2 levels. The room temperature sensor modulates the mixing dampers in sequence with DX cooling to maintain the cooling setpoint, and modulates the heating valve and face & bypass dampers in sequence to maintain the heating setpoint. The setpoint can be adjusted +/-2°C at the room sensor. Fan status is monitored by a current sensor.

FBD

DX

V1

HWR

HWS

OUTDOOR

AIR

OAD RAD

FAN

RETURN

AIR

Limits and Safeties

- 1) If the outside air temperature exceeds the global free cooling setpoint based on outdoor air humidity, the mixing dampers return to minimum position.
- 2) Mixed air damper minimum position control is provided during occupied periods (initially 10% OA).
- 3) Air quality sensor AQ1 increases the amount of minimum outside air as the space CO2 reading increases from 1000 ppm to 1200 ppm.
- 4) The fan must be running before the mixing dampers and DX cooling will operate.
- 5) The supply air temperature sensor acts as a low limit to ensure temperature does not fall below setpoint (initially 16°C, reset to 13°C on a call for free cooling).
- 6) A software freeze-stat on the supply air temperature shuts the fan down and closes the outdoor air damper when the supply air temperature is below 3°C for 30 seconds (resets at 6°C with 5 minute delay before restart).

10 k

T

TS15

CO

2

AQ1

7) Heating valve V1 opens as the outside air temperature drops from 3°C to -3°C.

8) If the hard-wired freeze-stat trips, the fan shuts down, outside air damper closes and heating valve opens.

9) DX cooling is disabled when the outside air temperature falls below the global mechanical cooling disable setpoint (initially 14°C).

AO
2-10 V
DO AI
0-5 V
0-20 A
AO
2-10 V
DO
AO
2-10 V
AI
COM
AI

0-10 V

0-2000 ppm

10) DX cooling has a minimum off time of 5 minutes.

11) DX cooling has a supply air temperature low limit (6/12°C).

12) The face & bypass damper is in the face position when DX cooling is operating.

Alarms

An alarm is indicated at the operator's terminal if any of the following occur:

- 1) Fan status does not match fan start/stop signal.
- 2) Room temperature too high (42/40°C) or too low (14/15°C).
- 3) Supply air temperature too high (65/60°C) or too low (5/7°C).
- 4) Room CO2 level too high (1700/1600 ppm) or too low (250/300 ppm).
- 5) Software freezestat tripped.
- 6) Fan runtime exceeded weekly runtime setpoint.

Indicate Heating Mode Runtime of Heat Pumps (discuss later)

5.6. Heat Pumps (referenced from Brigadoon, Jacob Hespler)

Unoccupied Mode

The supply fans are off, mixing dampers are in the 0% outside position, the heating and DX cooling are disabled. If the coldest space temperature falls

below the unoccupied heating setpoint (16/18°C) or the warmest space temperature exceeds the unoccupied cooling setpoint (30/28°C), all the fans will

cycle on with the outside air dampers closed. The furnaces where unoccupied temperature control is required will cycle to maintain setpoint. If the

override pushbutton is pressed on any room sensor, the system will revert to the occupied mode for a period of 2 hours (adjustable).

Occupied Mode

An optimum start routine calculates the required start time for the system. During morning warm-up and cool-down, the minimum outside air position is

set to zero. The supply fans run continuously. The fans run at ventilation (low) speed until heating or cooling is required, then they run at high speed.

The outdoor air damper opens to the minimum outdoor air setting. The return air CO2 sensor will increase the minimum outside air setpoint as the

measured CO2 level increases between 1000 and 1200 ppm.

Each furnace fan goes to high speed when heating or cooling is required.

When the outside air temperature exceeds the global heating disable setpoint, all heating is disabled.

The condensers act as heat-pumps. An outdoor air temperature setpoint is determined from energy consumption measurements. Above this setpoint,

initially set at -10 °C, the heating is supplied by the heat-pumps, but below this setpoint the gas heating is used.

Cooling is provided by opening the outside air dampers for free cooling when outdoor air conditions permit, otherwise the mechanical cooling runs.

Dehumidification is provided when the return air relative humidity is higher than setpoint (50% RH).

When the outside air temperature falls below the global DX cooling disable setpoint, or when the warmest zone deviation is less than 1°C, mechanical cooling is disabled.

The outdoor air flow rate is calculated according to each fan speed and outdoor air damper position and this cycles on the exhaust fans to balance the air flow.

Zone space temperature sensors cycle their respective zone damper to maintain setpoint. An adjustment of +/-1.5°C is provided at each room

temperature sensor. The default space temperature setpoint is raised 1°C when DX cooling is enabled.

Limits & Safeties

- 1) The mixed damper positions are limited based on outside air temperature to prevent excessive amounts of cold outside air on system start-up.
- 2) The DX compressors have a minimum off-time of 5 minutes.
- 3) The supply air temperature sensors act as a low limit to disable DX cooling or close the outdoor air if the temperature falls below 1/5°C (auto-reset, 1 minute delay before shutdown, 5 minute delay before restart).

Alarms

- 1) Supply air temperature too low (8/10°C) or too high (60/55°C).
- 2) Room temperature or return air temperature to low (14/15°C) or too high (38/36°C).
- 3) Supply fan status does not match the output signal.
- 4) Software freezestat tripped.
- 5) Return air CO2 too high (1800/1750 ppm) or too low (250/300 ppm).

Water Source (Brigadoon, Jacob Hespeler)

From Brigadoon

SEQUENCE OF OPERATION

Unoccupied Mode

The heat pump fan and compressor cycle to maintain unoccupied heating setpoint. If the pushbutton on the sensor is pressed, the system will revert to the occupied mode for a period of 2 hours.

Occupied Mode

The heat pump supply fan runs continuously. The room sensor cycles the heat pump compressor for heating or cooling as required to maintain setpoint. Setpoint adjustment (+/-2°C) is provided at the sensor. Runtime for heating and cooling is accumulated on a weekly basis.

Limits & Safeties

- 1) The compressor has a 5 minute minimum off time.
- 2) The supply fan has a 30 second delay-off time.

Alarms

- 1) Space temperature too low (14/15°C) or too high (32/31°C).
- 2) Supply air temperature too low (5/6°C) or too high (50/49°C).
- 3) Fan in the wrong state.
- 4) Heat pump fault.

From Jacob Hespeler

SEQUENCE OF OPERATION

Unoccupied Mode

The heat pump fan and compressor cycle to maintain unoccupied setpoints for heating and cooling.

If the

pushbutton on the sensor is pressed, the system will revert to the occupied mode for a period of 2 hours.

Occupied Mode

Optimized start control is provided. The heat pump supply fan runs continuously. The room sensor cycles the heat pump compressor for heating or cooling to maintain setpoint. Setpoint adjustment (+/-2°C) is provided at the sensor.

Limits & Safeties

- 1) The compressor has a 5 minute minimum off time.
- 2) The supply fan has a 30 second delay-off time.
- 3) On a fire alarm condition, the system turns off.

Alarms

- 1) Space temperature too low (14/15°C) or too high (32/31°C).
- 2) Supply fan in the wrong mode.

Roof Top Units (Preston HS Guidance office, WG Davis Music Rm, Laurelwood)

Preston HS Guidance office

ers are in the 0% outside air position, the heating is off and the cooling is off. The bypass damper is in the 100% open position. The zone dampers are in the 50% open position. The system cycles on a call for unoccupied heating, with the supply air static pressure setpoint increased by 20%.

If the override pushbutton is pressed, the system will switch to the occupied mode for 2 hours (adjustable).

OCCUPIED MODE

Fan Operation

The supply fan operates continuously. An optimized start routine is provided for heating and cooling.

Zone Damper

The room sensor modulates the zone damper between minimum and maximum settings to maintain setpoint. The setpoint is adjustable $\pm 1^{\circ}\text{C}$ at the sensor. The control is

reverse acting when the supply air temperature is more than 1°C above room temperature and direct acting when the supply air temperature is more than 1C below room temperature.

If the system mode is different from the zone mode (e.g. system is in heating mode but zone requires cooling), the zone damper closes to a reduced

minimum position to minimize overheating/overcooling.

System Heating/Cooling Decision Process

The system mode is determined by the number of zones that deviate from their respective zone heating/cooling setpoints. outnumber (or are equal to) the total number of zones requesting cooling, the system will go to heating mode.

If the total number of zones requesting heating

exceeds the total number of zones requesting cooling

the total number of zones requesting heating, the system will go to cooling mode. Once in the heating or cooling mode, the reference zone becomes the zone with the

greatest call. The system will lock-in the selected mode until all zones are satisfied.

If any zone is deprived of ventilation air for more than 20 minutes, the system will

“unlock”, go into forced ventilation mode for 5 minutes, and then reselect the required mode of operation. Zones designated as “slave zones” (typically corridors) cannot

request heating or cooling, but will utilize heating/cooling when it is available.

The rad valves provide the first stage of heat. The heat pump will provide heating when the outdoor air temperature is warmer than the heat pump enable setpoint.

Ventilation Mode

The system operates in ventilation mode (no heating or cooling) under the following conditions:

- 1) No zones are calling for heating or cooling.
- 2) System is switching between heating and cooling (system operates in ventilation mode for 5 minutes).
- 3) One or more zones have been operating at a reduced minimum position for more than 20 minutes (system operates in forced ventilation mode for 5 minutes).

System Heating Control

Stage 1 and stage 2 heating are controlled from the reference zone as follows:

Reference Zone Call for Heat

Stage 1 On

Stage 1 Off

Stage 2 On

Stage 2 Off

1.0°C

0.5°C

1.5°C

1.0°C

System Cooling Control

Stage 1 and stage 2 cooling are controlled from the reference zone as follows:

Reference Zone Call for Cooling

Stage 1 On

Stage 1 Off

Stage 2 On

Stage 2 Off

1.2°C

0.5°C

1.5°C

0.9°C

Economizer Operation

Economizer operation will be substituted for first stage cooling when the outside air temperature is suitable. For units with power exhaust, the exhaust fan runs when the outside air damper is more than 50% open. The CO₂ sensor will increase the amount of minimum outside air as the CO₂ level increases from 1000 ppm to 1200 ppm. During morning warm-up or cool-down the outside air minimum position is set to zero.

Bypass Operation

The supply air static pressure sensor modulates the bypass damper between minimum and maximum settings to maintain setpoint.

Limits & Safeties (VVT ver. 3)

1)

If the outside air temperature exceeds the average zone temperature, the mixing dampers return to minimum outside air position.

2) The maximum amount of outside air is limited based on the outside air temperature to prevent excessively low supply air temperatures during startup.

3) The mixed air temperature sensor acts as a low limit to ensure temperature does not fall below setpoint.

In applications where the mixed air sensor is

located after the DX coil, the setpoint is reduced when DX cooling is enabled.

4) The supply air temp. sensor acts as a high limit for heating (70/55°C, 60/45°C) and a low limit for cooling (5/10°C, 8/13°C).

5) The supply air temperature sensor acts as a software freezestat (1/5°C, 3 min. delay, auto reset after 5 min. delay).

6) The supply fan has a delay-off time of 90 seconds.

7) DX cooling has a minimum-off time of 5 minutes.

8) DX cooling is disabled when the outside air temp. is below the global DX disable setpoint or when the fan is off.

9) Gas heating is disabled when the outside air temp. is above the global heating disable setpoint or when the fan is off.

10) Stage 1 gas heating has a minimum run time of 3 minutes.

11) During ventilation mode, if the supply air temperature falls below 15°C for more than two minutes, stage 1 heating will turn on until the temperature exceeds 25°C (to improve comfort).

12) The default zone setpoint is increased by 1°C when mechanical cooling is enabled (providing heating is disabled).

13) When the ventilation lockout switch is engaged, the outside air dampers close, and the system switches to unoccupied mode of operation.

14) Minimum outside air is set to zero when the global ventilation schedule is off (stand-by occupancy).

Alarms

An alarm will be generated upon the following conditions:

1) Fan status does not match the start/stop signal.

2) Mixed air temperature too high (50/48°C) or too low (5/7°C).

3) Supply air temperature too high (65/63°C) or too low (5/7°C).

4) Space temperature too high (42/40°C) or too low (14/16°C).

5) Supply air static pressure too low (10/20 Pa) or too high (240/230 Pa).

6) Weekly fan runtime limit exceeded.

7) Return air CO₂ too high (1700/1650 ppm) or too low (250/300 ppm).

8) Software freezestat tripped.

WG Davis Music Room

SEQUENCE OF OPERATION

UNOCCUPIED MODE

The supply fan is off, the mixing dampers are in the 0% outside air position, the heating is off and the cooling is off. The bypass damper is in the 100% open position. The zone dampers are in the 50% open position. The system cycles on a call for unoccupied heating, with the supply air static pressure setpoint increased by 20%. If the override pushbutton is pressed, the system will switch to the occupied mode for 2 hours (adjustable).

OCCUPIED MODE

Fan Operation

The supply fan operates continuously. An optimized start routine is provided for heating and cooling.

Zone Damper

The room sensor modulates the zone damper between minimum and maximum settings to maintain setpoint. The setpoint is adjustable +/-1°C at the sensor. The control is reverse acting when the supply air temperature is more than 1°C above room temperature and direct acting when the supply air temperature is more than 1°C below room temperature. If the system mode is different from the zone mode (e.g. system is in heating mode but zone requires cooling), the zone damper closes to a reduced minimum position to minimize overheating/overcooling.

System Heating/Cooling Decision Process

The system mode is determined by the number of zones that deviate from their respective zone heating/cooling setpoints. If the total number of zones requesting heating outnumber (or are equal to) the total number of zones requesting cooling, the system will go to heating mode. If the total number of zones requesting cooling outnumber the total number of zones requesting heating, the system will go to cooling mode. Once in the heating or cooling mode, the reference zone becomes the zone with the greatest call. The system will lock-in the selected mode until all zones are satisfied. If any zone is deprived of ventilation air for more than 20 minutes, the system will "unlock", go into forced ventilation mode for 5 minutes, and then reselect the required mode of operation. Zones designated as "slave zones" (typically corridors) cannot request heating or cooling, but will utilize heating/cooling when it is available.

Ventilation Mode

The system operates in ventilation mode (no heating or cooling) under the following conditions:

- 1) No zones are calling for heating or cooling.
- 2) System is switching between heating and cooling (system operates in ventilation mode for 5 minutes).
- 3) One or more zones have been operating at a reduced min. position for more than 20 minutes (system operates in forced ventilation mode for 5 minutes).

System Heating Control

Stage 1 heating is the heat pump and stage 2 heating is gas. They are controlled from the reference zone as follows:

Reference Zone Call for Heat

Stage 1 On

Stage 1 Off

Stage 2 On

Stage 2 Off

1.0°C

0.5°C

1.5°C

1.0°C

System Cooling Control

Cooling 1 is controlled from the reference zone as follows:

Reference Zone Call for Cooling

Stage 1 On

Stage 1 Off

1.2°C

0.5°C

Economizer Operation

Economizer operation will be substituted for first stage cooling when the outside air temperature is suitable. For units with power exhaust, the exhaust fan runs when the outside air damper is more than 50% open. The CO2 sensor acts as a high limit and will increase the amount of minimum outside air as the CO2 level increases from 1000 ppm to 1200 ppm. During morning warm-up or cool-down the outside air minimum position is set to zero.

Bypass Operation

The supply air static pressure sensor modulates the bypass damper between minimum and maximum settings to maintain setpoint.

Limits & Safeties

- 1) If the outside air temperature exceeds the average zone temperature, the mixing dampers return to minimum outside air position.
- 2) The maximum amount of outside air is limited based on the outside air temperature to prevent excessively low supply air temperatures during startup.
- 3) The mixed air temperature sensor acts as a low limit to ensure temperature does not fall below setpoint. In applications where the mixed air sensor is located after the DX coil, the setpoint is reduced when DX cooling is enabled.
- 4) The supply air temp. sensor acts as a high limit for heating (70/55°C, 60/45°C) and a low limit for cooling (5/10°C, 8/13°C).
- 5) The supply air temperature sensor acts as a software freeze-stat (1/5°C, 3 min. delay, auto reset after 5 min. delay).
- 6) The supply fan has a delay-off time of 90 seconds.
- 7) DX cooling has a minimum-off time of 5 minutes.
- 8) DX cooling is disabled when the outside air temp. is below the global DX disable setpoint or when the fan is off.
- 9) Gas heating is disabled when the outside air temp. is above the global heating disable setpoint or when the fan is off.
- 10) Stage 1 gas heating has a minimum run time of 3 minutes.
- 11) During ventilation mode, if the supply air temperature falls below 15°C for more than two minutes, stage 1 heating will turn on until the temperature exceeds 25°C (to improve comfort).

- 12) The default zone setpoint is increased by 1°C when mechanical cooling is enabled (providing heating is disabled).
- 13) When the ventilation lockout switch is engaged, the outside air dampers close, and the system switches to unoccupied mode of operation.
- 14) Minimum outside air is set to zero when the global ventilation schedule is off (stand-by occupancy).
- 15) The heat pump provides the cooling and it also provides the heating when the outdoor air temperature is above -10°C for efficient operation.

Alarms

An alarm will be generated upon the following conditions:

- 1) Fan status does not match start/stop signal.
- 2) Mixed air temperature too high (50/48°C) or too low (5/7°C).
- 3) Supply air temperature too high (65/60°C) or too low (5/7°C).
- 4) Space temperature too high (42/40°C) or too low (14/15°C).
- 5) Supply air static pressure too low (10/15 Pa) or too high (240/220 Pa).
- 6) Weekly fan runtime limit exceeded.
- 7) Return air CO2 too high (1700/1600 ppm) or too low (250/300 ppm).
- 8) Software freezestat tripped.

Make Up Air Units Reference:

Unoccupied Mode

The outside air damper is closed, the supply fan is off, the associated exhaust fan(s) are off, the heating valve is open to the coil and the cooling valve is closed to the coil. When the outside air temperature is below 5 °C, the coil circulating pump is on. If the classroom extended day timer contacts close, the units switch to occupied mode.

Occupied Mode

The outside air damper is open, and the supply fan runs continuously. Supply air temperature sensor TS1 modulates the heating valve in sequence with the cooling valve to maintain setpoint which is reset from outside air temperature as follows:

OAT SAT SP

10 °C 14 °C

-20 °C 20 °C

Before the cooling valve begins to open, the coil circulating pump stops and the diverting valve switches to cooling. The same time schedule is used for the make-up air unit and the associated group of fan-coil units.

Limits and Safeties

- 1) Freezestat FZ1 closes the outside air damper and shuts down the supply and exhaust fan(s) if the temperature falls below setpoint.
- 2) Cooling is disabled when the chiller is off.
- 3) The heating valve has a minimum position which increases as the outside air temperature drops as follows:

OAT Htg Valve

10°C 0%Htg

-20°C 80%Htg

- 4) A supply air low limit control opens the heating valve as follows:

SAT Htg Valve

12°C 0%Htg

2°C 100%Htg

- 5) The supply fan has a 20 second delay-off.
- 6) A software freezestat will shut down the supply fan if the supply air temperature falls below setpoint (4/7°C, 5s delay on, 3min delay before restart).

Alarms

- 1) Supply fan in incorrect mode.
- 2) Supply air temperature deviation from setpoint too low (-6/-5 °C, 600 second delay).
- 3) Supply air temperature deviation from setpoint too high (6/5 °C, 600 second delay).

KCI (not a kitchen unit) serves VAV boxes

Unoccupied Mode

The supply fan is off, the outside air damper is closed and the heating is off. If any associated room sensor pushbutton is pressed, the system switches to occupied mode for a period of two hours.

Occupied Mode

The supply fan runs continuously. The supply air temperature sensor modulates heating to maintain a setpoint of 18°C via built-in factory supplied controls. The BAS can reset the setpoint +/-6°C (based on outside air temperature and/or space demand).

Limits & Safeties

- 1) The Eng. Air unit has an integral low limit auto bypass set at 4.4 °C.
- 2) The Eng. Air unit has a blower delay-on timer.
- 3) Supply air temperature sensor acts as a software freezestat and will shut down the system if the temperature falls below 4 °C for more than 30 seconds (auto reset with 10 minute delay).

Alarms

An alarm will be generated upon the following conditions:

- 1) Fan status does not match the start/stop signal.
- 2) Supply air temperature too high (55/50°C) or too low (5/7°C).
- 3) Software freezestat tripped.
- 4) Fan weekly runtime exceeded.

Furnace Reference:

Gym Storage Room - Sir Adam Beck

The single stage gas burner is cycled to maintain the room temperature at setpoint. During occupied times the setpoint is 19°C but in unoccupied times the heating setpoint is 17°C (all setpoints are adjustable). The fan runs according to its built-in fan control.

If the outdoor air temperature is above 10°C the unit is disabled.

An alarm is generated if the room temperature is too low (14/15°C) or too high (38/36°C).

Gym Change Rooms - JF Carmichael

Unoccupied Mode

The supply fan is off, the gas heating is off, EF1 & 2 are off and the outside air damper is closed. If the space temperature drops below the unoccupied heating setpoint, the system will cycle to occupied mode, but with the outside air damper closed and exhaust fans off. If the pushbutton on the room sensor is pressed (for extended day function), the system switches to the occupied mode for two hours.

Occupied Mode

The occupied mode start time is based on an optimized time schedule. The supply fan is on, the outside air damper is open and EF1 & EF2 are on. The room temperature sensor cycles the gas heating to maintain setpoint. Indication is provided for mixed air temperature.

Limits and Safeties

- 1) The fan delays off 5 minutes to allow heat to be dissipated.
- 2) The gas heating is locked out when the outside air temperature exceeds the global heating disable setpoint.

Alarms

An alarm is generated at the BAS on the following conditions:

- 1) The supply fan status does not match the start/stop signal.
- 2) The room temperature drops below the low alarm setpoint (14/15°C).
- 3) The mixed air temperature drops below the low alarm setpoint (8/10°C).
- 4) Exhaust fan status does not match the expected status based on the outside air damper position.

5.6.1. Washroom Exhaust Fans

Fans operate according to the time schedule.

An alarm is generated if the fan status does not match the start/stop signal.

5.6.2. Other Exhaust Fans

(Kitchen Exhaust Fan reference Cafeteria EDSS Elmira, or Oak Creek for Daycare interlocking cooling with kitchen exhaust fan, Grand River Collegiate, Saginaw)

Kitchen Exhaust Fan reference Cafeteria EDSS Elmira

SEQUENCE OF OPERATION

Unoccupied Mode

The supply fan is off, the mixing dampers are in the 0% outside air position, the heating is off and the cooling is off. The fan cycles on a call for unoccupied heating. If the override pushbutton is pressed, the system will switch to the occupied mode for 2 hours (adjustable).

Occupied Mode

An optimized start routine is provided for heating and cooling. During morning warm-up or cool-down the outside air minimum position is set to zero. The supply fan runs continuously at a constant speed. The room temperature sensor modulates the heating to maintain the occupied heating setpoint. It also modulates the mixing dampers (for free cooling) and modulates the cooling to maintain the occupied cooling setpoint. Local setpoint adjust (+/-2°C) is provided. The power exhaust fan cycles based on the rooftop economizer position (50% On/40% Off).

Whenever the kitchen exhaust hood fan is on, the DX cooling on the two fans are locked off. Free cooling will still operate if the outdoor conditions are favourable.

Limits & Safeties

- 1) Minimum outside air is provided by the energy recovery ventilator when enabled by the global minimum outside air time schedule.
- 2) The return air carbon dioxide sensor acts to increase the amount of minimum outside air from 0 to 40% as the reading increases from 1000 ppm to 1200 ppm.
- 3) If the outside air temperature exceeds the global free cooling setpoint (indicating that free cooling is unavailable) the mixing dampers return to minimum outside air position.
- 4) The maximum amount of outside air is limited based on the outside air temperature to prevent excessively low supply air temperatures during startup.
- 5) The mixed air temperature sensor acts as a low limit to ensure temperature does not fall below setpoint.
- 6) The supply air temperature sensor acts as a high limit for heating (58/48°C) and a low limit for cooling (9/14°C).
- 7) The supply air temperature sensor acts as a software freeze-stat (2/5°C, 3 minute delay, auto reset after 5 minute delay).
- 8) The supply fan has a delay-off time of 90 seconds.
- 9) Cooling cannot turn on until heating has been off for a minimum of 5 minutes.
- 10) DX cooling has a minimum off-time of 5 minutes.
- 11) DX cooling is disabled when the outside air temperature is below the global DX disable setpoint or when the fan is off.
- 12) During occupied hours heating has a delay-on time of 15 minutes, except when the outside air temperature is below -3/-1°C.
- 13) Gas heating is disabled when the outside air temperature is above the global heating disable setpoint or when the fan is off.
- 14) When ventilation lockout is engaged the outside air dampers close and the unit switches to unoccupied mode.
- 15) On a fire alarm condition, the system shuts down.

Alarms

An alarm will be generated upon the following conditions:

- 1) Fan status does not match the start/stop signal.
- 2) Supply air temperature too high (65/60°C) or too low (5/10°C).
- 3) Space temperature too high (36/34°C) or too low (16/14°C).
- 4) Mixed air temperature too high (50/48°C) or too low (5/7°C).
- 5) Fan runtime exceeded weekly setpoint.
- 6) Software freeze-stat tripped.
- 7) Return air CO2 too high (1700/1650 ppm) or too low (250/300 ppm).

Oak Creek for Daycare interlocking cooling (Carrier Ductless Split A/C Unit) with kitchen exhaust fan

SEQUENCE OF OPERATION

Unoccupied Mode

The system is off.

If the pushbutton on the room sensor is pressed, the system will switch to the occupied mode for a period of 2 hours (adjustable).

Occupied Mode

This is the first stage of cooling for VVT zone G9. Zone temperature sensor TS15 cycles the ductless split to maintain the occupied cooling setpoint.

The unit is disabled when the kitchen hood is on or if the outside air temperature is below the global mechanical cooling disable setpoint (initially 12/14°C). A minimum off-time of 5 minutes is provided.

Alarms

An alarm is generated at the BAS if the zone temperature exceeds programmed alarm limits.

Grand River Collegiate (Fume Hood)

SEQUENCE OF OPERATION

The BAS provides AUTO/ON control of the fume hood exhaust fan according to a time schedule. Fan status is monitored by a current sensor.

If the fan status is

off when commanded on, an alarm will be generated at the BAS.

When the fan status is on, the return air dampers close to a position as determined by the air balancer (mechanical stop). If the fume hood fan is running when the rooftop unit is off, the transfer damper opens to provide air the room.

Saginaw (General Exhaust Fans)

SEQUENCE OF OPERATION

Fans operate according to the time schedule.

An alarm is generated if the fan status does not match the start/stop signal.

Kitchen Hood EF-3 is operated manually. Fan status is monitored only.

Science Lab Prep (BAS enable relay to run for 30 minutes every 6 hours for a flush/purge) Cameron Heights, Grand River