

Field wiring diagram for Sir Allan MacNab Secondary

Project segment	New NFPZ3000-2HE
Client/facility name	Sir Allan MacNab Secondary School
Facility address	145 Magnolia Dr
City, State, Zip	Hamilton, ON L9C 5P4
Client contact person	
Contact phone #	
Purchased by (if not client)	
Contact person	
Contact phone #	
Nederman project manager	Joe Hayes
Contact phone #	704-998-2635

Purpose of this issued field wiring diagram:

Field wiring diagram final for the project with data on Nederman supplied components - FOR APPROVAL

APPROVED FOR CONSTRUCTION
 BY: _____
 FOR: _____
 DATE: _____
 WITH CORRECTIONS/CHANGES AS NOTED

Primary supply voltage	3x575	VAC
Full Load Current (FLC)	24	A
Secondary supply voltage	N/A	VAC
Full Load Current (FLC)		A
Control voltage	24	VDC
Frequency	60	Hz

REVIEWED REVIEWED AS NOTED
 REVISE & RESUBMIT REJECTED
 THE INTENTION OF THIS REVIEW IS TO ASCERTAIN CONFORMANCE WITH THE GENERAL DESIGN CONCEPT. IT DOES NOT RELIEVE THE CONTRACTOR AND MANUFACTURER OF RESPONSIBILITY FOR DIMENSIONAL ACCURACY, OMISSIONS, ERRORS AND COMPLIANCE WITH THE CONTRACT DRAWINGS AND DOCUMENTS.
 BY: *C. Park* DATE: Mar.9/26
COPA ENGINEERING LTD.

THE DUST COLLECTOR SHALL BE INSTALLED 1200M AWAY FROM WALL

ROOT3 ENGINEERING LTD
 THIS DOCUMENT HAS BEEN REVIEWED BY ROOT3 ENGINEERING LTD FOR GENERAL CONFORMANCE AND DESIGN INTENT. THIS DOES NOT RELEASE THE CONTRACTOR OF RESPONSIBILITY FOR CONFORMANCE WITH THE DESIGN DRAWINGS AND SPECIFICATIONS.
REVIEWED
 DATE: Mar 23, 2026
 BY: S.H.

**ROOT3:
 REVIEWED FOR
 ELECTRICAL
 POWER ONLY.**

Notice:
 All data on Nederman supplied components close estimate for budgetary purpose supplied with final documents.
 All other data must be calculated and/or verified for actual field conditions to meet and standards. These calculations and sizing must be done by authorized electrician.

Revision	Approved	Date	Drawn	Date
			CS	27-02-2026

GS | GACESA SLOTE ARCHITECTS

Reviewed
Reviewed as noted

Revise and resubmit
Not reviewed

Date: 03/23/2026

Reviewed by: gacesa

This review by GS | Gacesa SLOTE Architects is for the sole purpose of ascertaining conformance with the general design concept for architectural features only and does not in any way constitute review of the design of engineering elements which form part of the contract documents prepared by others. This review shall not mean that GS | Gacesa SLOTE Architects approves the detailed design inherent in the shop drawings, responsibility for which shall remain with the Contractor submitting same, and such review shall not relieve the Contractor of his responsibility for errors, or omissions in the shop drawings or of the responsibility for meeting all requirements of the Contract Documents. The Contractor is responsible for dimensions to be confirmed and correlated at the job site, for information that pertains solely to fabrication processes or to techniques of construction and installation and for coordination of the work of all trades.

Instructions for installation of power circuits and other field wiring.

NO ATTEMPT SHALL BE MADE TO OPERATE THE EQUIPMENT UNTIL THE IOM MANUAL IS READ AND THE PRINCIPALS OF OPERATION AND FUNCTION OF ALL COMPONENTS ARE THOROUGHLY UNDERSTOOD. ONLY TRAINED AND AUTHORIZED PERSONNEL SHOULD BE ALLOWED TO OPERATE, ADJUST OR MAINTAIN THIS EQUIPMENT.

Electrical conductors, conduits and other field wiring are to be sized by qualified licensed electrician only. Information in this document is for reference only and must be verified in accordance with applicable codes and standards using actual field conditions.

	Description	Nederman supply	Supply by others
1	Supply and install all field wiring, terminating at both ends.		X
2	Supply and install safety disconnect switches-fused/unfused - as required by NEC for all motors and panels		X
3	Only stranded THHN wire is to be used for field terminations		X
4	VFDs must be protected with high speed class "J" fuses per VFD warranty		X
5	Main control panel is a NEMA 12 enclosure and must be installed indoor, protected by a fusible disconnect with time delayed fuses – circuit breakers are not allowed		X
6	Main control panel and other panel boxes conduit penetrations are to be from the bottom only. Top and/or side penetration will void Nederman warranty.		X
7	All drawings are schematics only and do not represent actual conduit layouts. Power distribution, conduit layout, fittings and accessories are supplied and installed by electrical installation contractor in accordance with current edition of NEC, local codes and AHJ's guidelines.		X
8	No wire nuts are allowed to be used per NFPA 79, 13.5.9.2. Use crimp connections, lugs and split bolts, Polaris connectors, or some other acceptable connection method and insulate with appropriate electrical rubber tape and electrical vinyl tape. Insulation material must not support combustion.		X
9	If HANSENTEK system is included follow following instructions: Hansentek controls are to be terminated by certified Nederman technician only. Wiring between Hansentek control panel, detectors and extinguishment system are to be coiled 2 feet at each end.		X
10	14 AWG, 4-conductor - non-shielded and 18 AWG 4-conductor (for extinguishment system) – shielded cables (for detectors) provided with Flamex equipment is for Hansentek components only.		X
11	All power conductors between each VFD and each motor shall be running separate metal conduit		X

Motor and power list

Main control panel(s) - power requirements

Drawing ID	Description	Voltage	FLC	Fuse type	Fuse/ ckt bkr	Disconnect size	Wire from	Wire type	Remarks
		Volt	Amp		A				
CNTP 1	Control panel NFP shaker	3x575VAC	2	CC	3	30	Buss plug	THHN	

Additional motors powered from main control panel

Drawing ID	Description	Model	Power	Voltage	FLC	Circuits are fused in main control panel with motor starters	Disconnect size	Wire from	Wire type	Remarks
			HP	Volt	Amp					
SH 1	Shaker motor NFP	SH mtr 0.14 HP	0.14	3x575VAC	0.9		30	CNTP 1	THHN	

Power requirements for other motors in the system

Drawing ID	Description	Starter type	Power	Voltage	FLC	Fuse type	Fuse size	Disconnect size	Wire from	Wire type	Remarks
			HP	Volt	Amp	A					
MF 1	Main fan 1	VFD	20	3x575VAC	22	High speed J	25	60	VFD 1	THHN	

Motor and power list

Top Down Power and motor wiring diagram.

See motor and power list for performance and size requirements.

Note: All power conductors between each VFD and each motor shall be running separate metal conduit

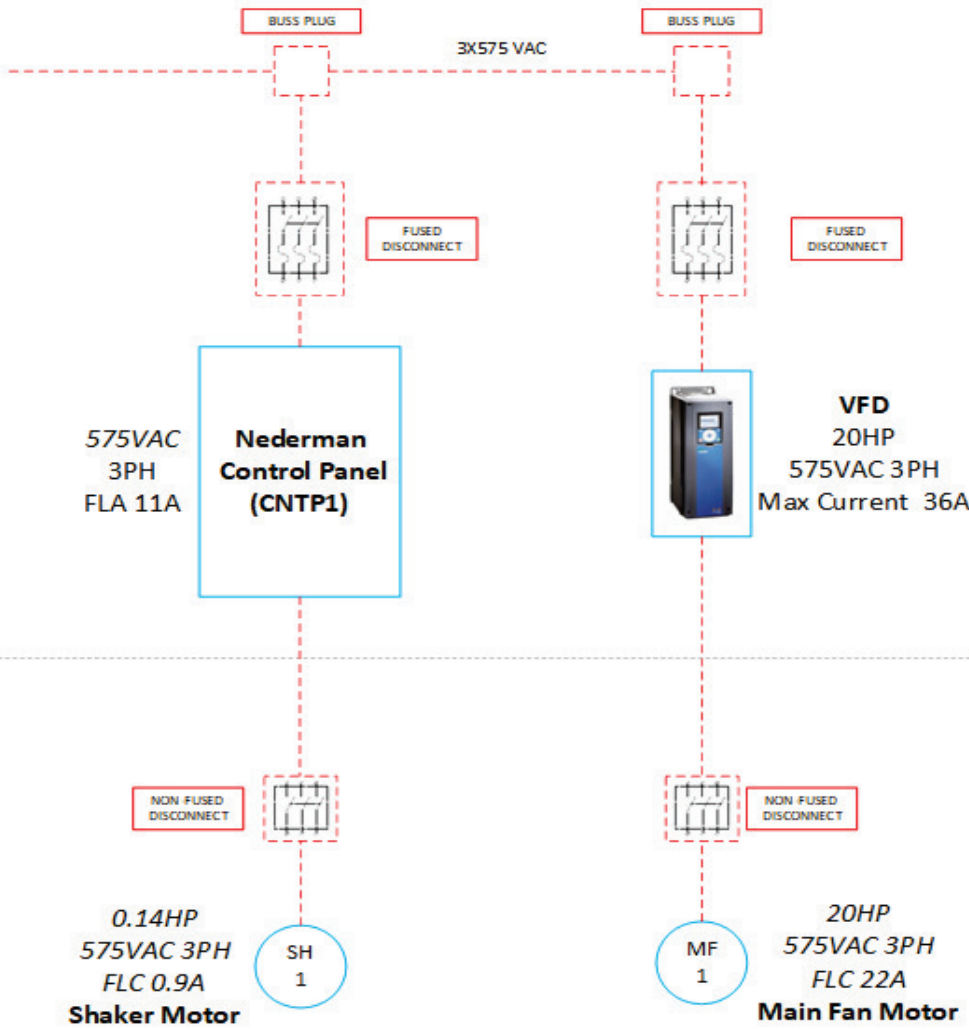

Legend:

- - - - - By others
- Nederman supply

Power wiring diagram

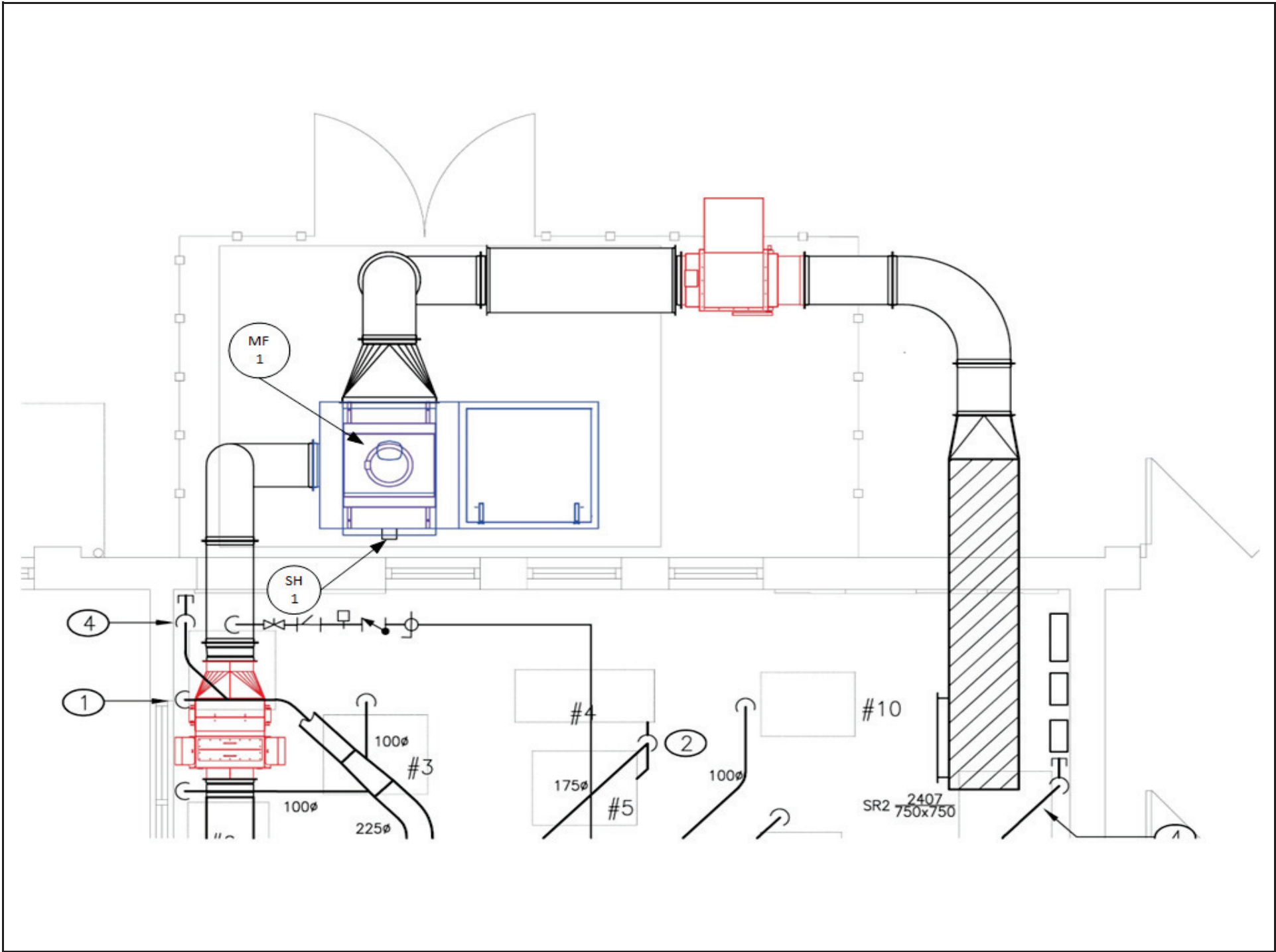

Power connection GA

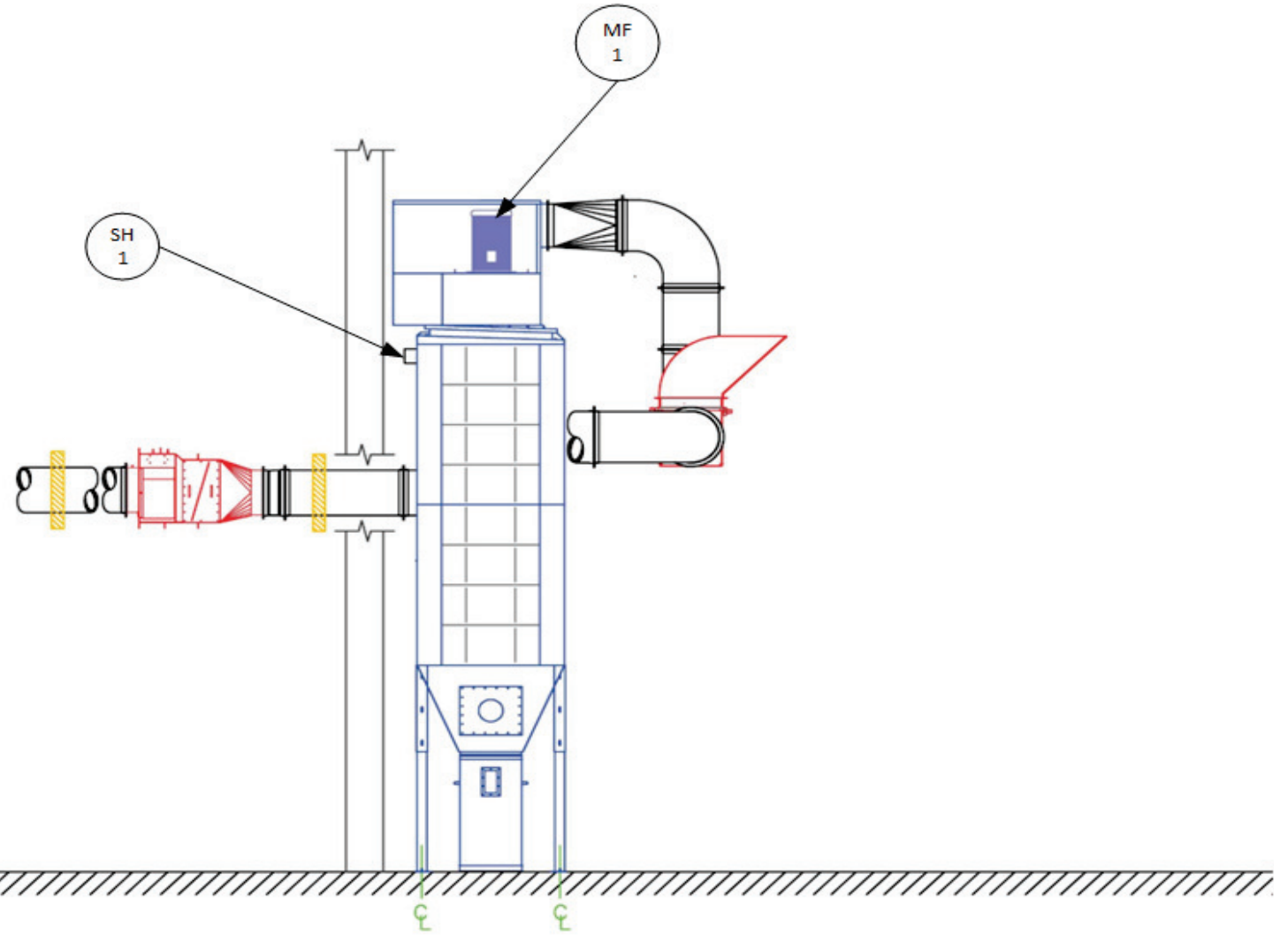

Power connection GA

**20 HP VACON 100 FLOW VFD, MR6
Frame Size**



***Note: To make sure that the drive operates correctly and has a long life, it is recommended that you do regular maintenance. Refer to the table for maintenance intervals**

General Specifications – 525-600V Drives

Line In Voltage	525-600VAC
Control Voltage	24VDC
VFD Mounting	Wall-Mount
Phase / Frequency	3-Phase / 60 Hz
Enclosure Ingress Protection	IP 54 / Type 12
SCCR	10kA @ 500V

Torque Specifications

Power and Motor Terminals	1.2-1.5 Nm (10.6-13.3 lb-in.)
EMC Grounding Clamps	1.5 Nm (13.3 lb-in.)
Grounding Terminals	2 Nm (17.7 lb-in.)

Drive Current/Fuse Specification (Use Class T or High-Speed Class J Fuse)

Power	20 HP (15 kW)
Drive Type	0022
Drive Current	22A
Fuse Specification	25A

Maintenance interval	Maintenance task
Regularly	Do a check of the tightening torques of the terminals. Do a check of the filters.
6-24 months (different intervals depending on environment)	Do a check of the input and output terminals and the control I/O terminals. Make sure that the cooling fan operates correctly. Make sure that there is no corrosion on the terminals, the busbars or other surfaces. Do a check of the door filters, if you have a cabinet
24 month	Clean the heatsink and the cooling tunnel.
3-6 years	In IP54, change the internal fan.
6-10 years	Change the main fan.
10 years	Replace the battery of the RTC.

VFD information

20 HP VACON 100 FLOW VFD, MR6
Frame Size

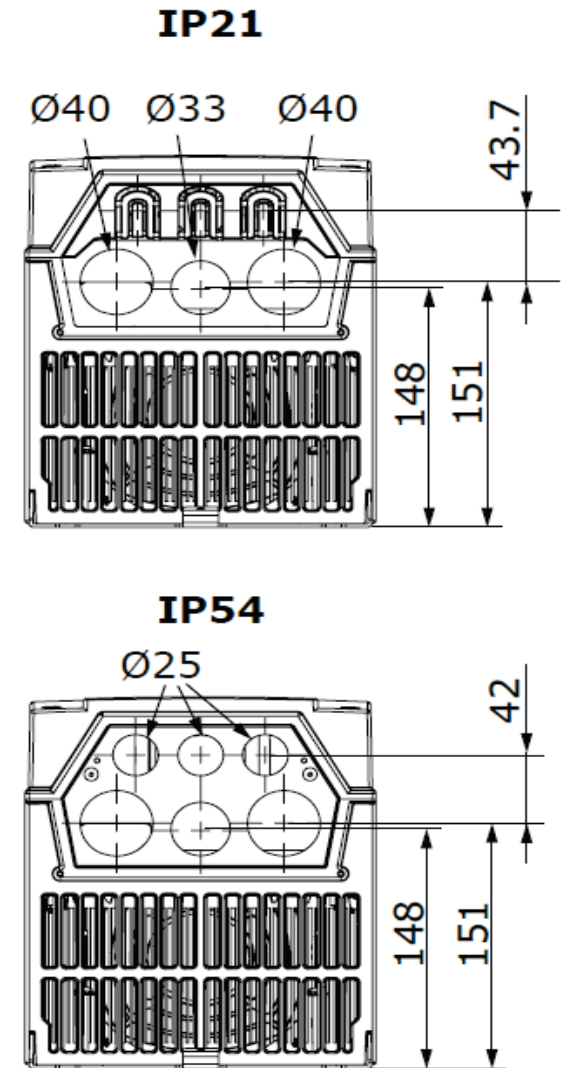
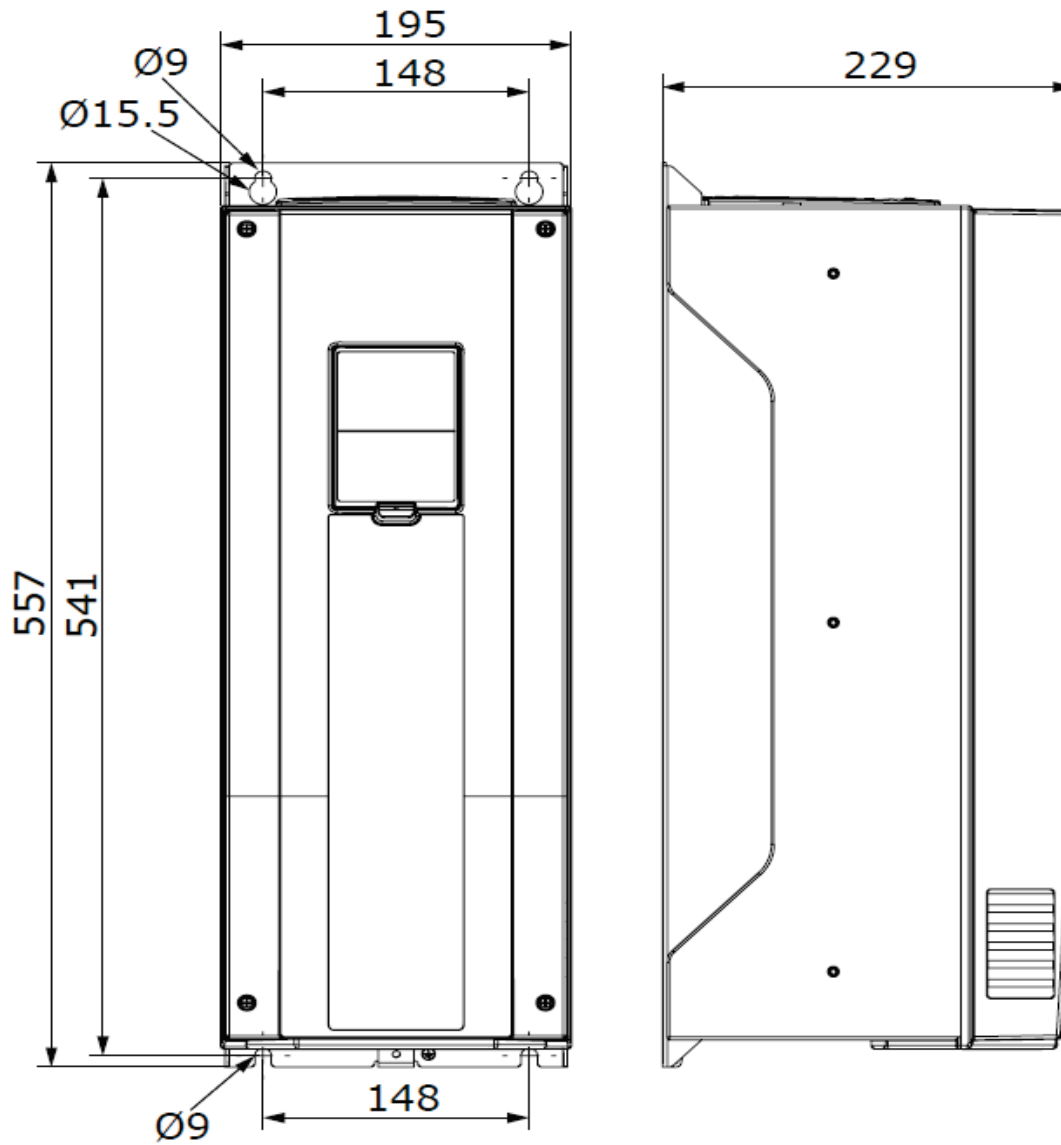

VFD information

20 HP VACON 100 FLOW VFD, MR6
Frame Size

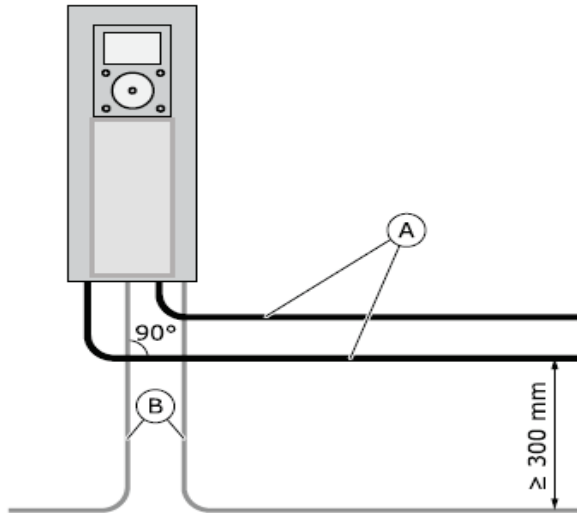

A – MOTOR CABLES B – FIELDBUS CABLES

***NOTE:** It is Important that Fieldbus cables are routed separately from motor cables. The recommended minimum distance is 300mm. Do not let fieldbus cables and motor cables cross each other. If it is not possible, the fieldbus cables must cross other cables at an angle of 90 degrees.

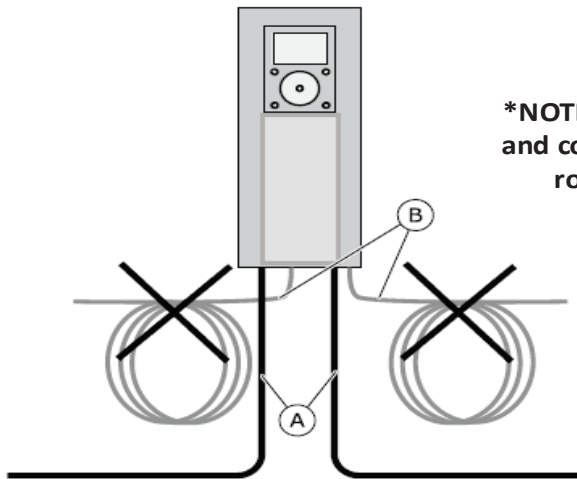

***NOTE:** Shielded fieldbus and control cables can be routed in parallel

Minimum Clearances Around the AC Drive in mm (Inch)

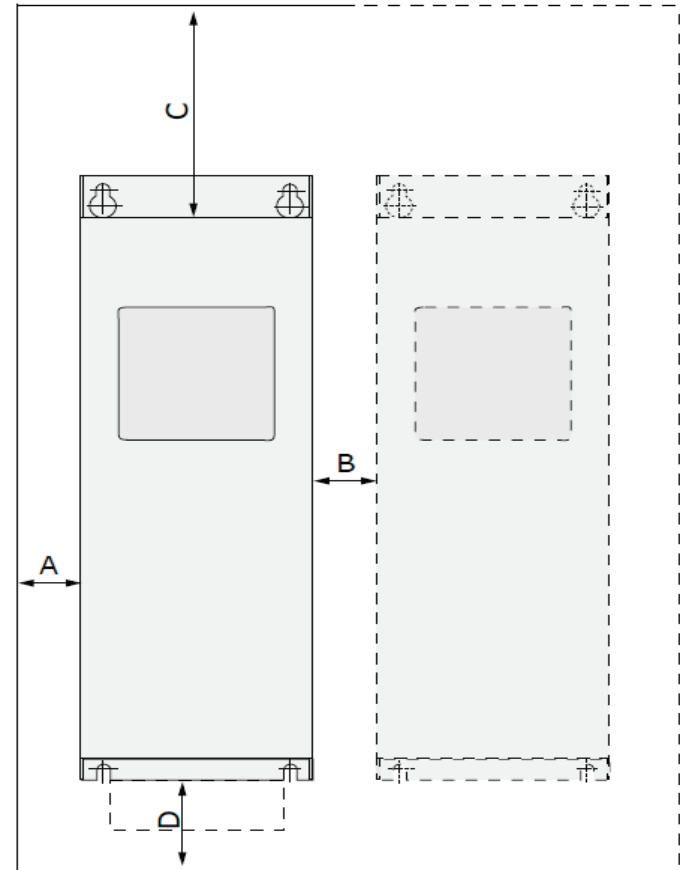

- | | |
|---|---------------------|
| A. The clearance around the drive (see also B and C) | 20 mm (0.8 inches) |
| B. The distance from a drive to a second drive, or the distance to the cabinet wall | 20 mm (0.8 inches) |
| C. The free space above the drive | 160 mm (6.3 inches) |
| D. The free space below the drive. | 80 mm (3.1 inches) |

VFD information

All equipment must be connected to grounding rods

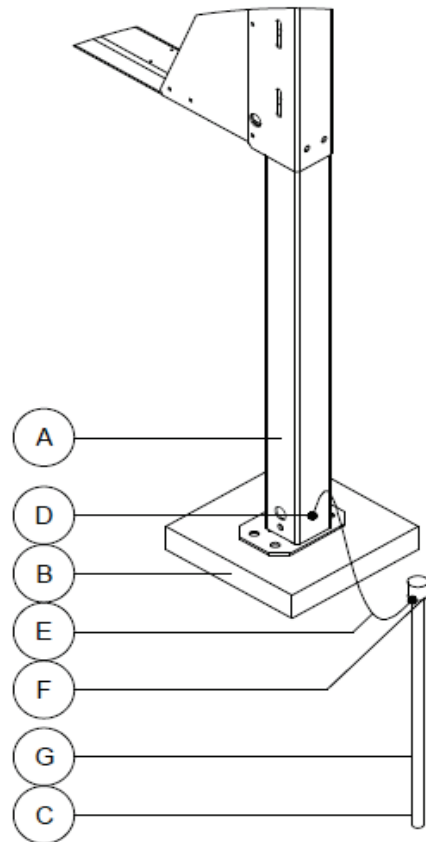

COLLECTOR GROUNDING

- A. STEEL SUPPORT FOR FILTER
- B. FOUNDATION
- C. SOIL. MINIMUM DEPTH 10 ft
- D. CONNECTION 3/8" BOLT AND NUT + CABLE LUG
- E. CABLE CONNECTION. SIZE 10 – 3 AWG, HOWEVER, AT LEAST 50% OF LARGEST CONDUCTOR CONNECTED TO THE SYSTEM, BUT MAX. 3 AWG.
- F. CONNECTION LUG OR BOX FOR GROUNDING ROD.
- G. GROUNDING ROD – COPPER MIN. 1/2" MIN. LENGTH 8 FT (MUST 10 FT INTO GROUND)

**Illustration shown as example only
Contractor must ground according to codes**





Equipment grounding details





This table identifies all low voltage circuits.

Use the layout drawings to identify location of device (Dwg ID) to land cable and the origin of the cable is shown in the column "Wire from". Use the power wiring diagram for panel ID. Pin-out for sensors and devices are shown in electrical schematic supplied with control panel(s). All wires must be labeled with control panel terminal strip numbers.

Please note any comments in the "Remark" column for additional instructions

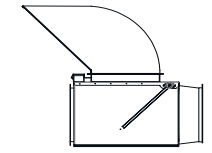
All connections between control panel(s) and devices are to be multi-conductor cables to each device.

Dwg ID	Description	Image	Wire from	Signal	Wire type	Wire gauge minimum	Remarks
VFD(x)-C(x)	Digital communication with VFD		CNTP(x)	24 VDC	2 cond.	16 AWG min.	
EXD-C(x)	Explosion door switch		CNTP(x)	24 VDC	2 cond.	18 AWG min.	Connect in series
HND-C(x)	Hansentek detector		HNTK	24 VDC	4 cond. shielded.	18 AWG min.	
HNE-C(x)	Hansentek extinguishing system assembly w/ solenoid and flow switch		HNTK	24 VDC	4 cond.	14 AWG	

HSAM-C(x)	HSAG interlock with main control panel		CNTP	24 VDC	2 cond.	14 AWG min.	
HSAH-C(x)	Drop release circuit from Hansentek AN-104 panel		HNTK	120 VAC	2 cond.	14 AWG min.	From Hansentek panel
EIFVL-C(x)	Locking switch on CARZ valve		CNTP(x)	24 VDC	2 cond.	18 AWG min.	
EIFVA-C(x)	Dust accumulation sensor		CNTP(x)	24 VDC	2 Cond. Shielded.	18 AWG min.	

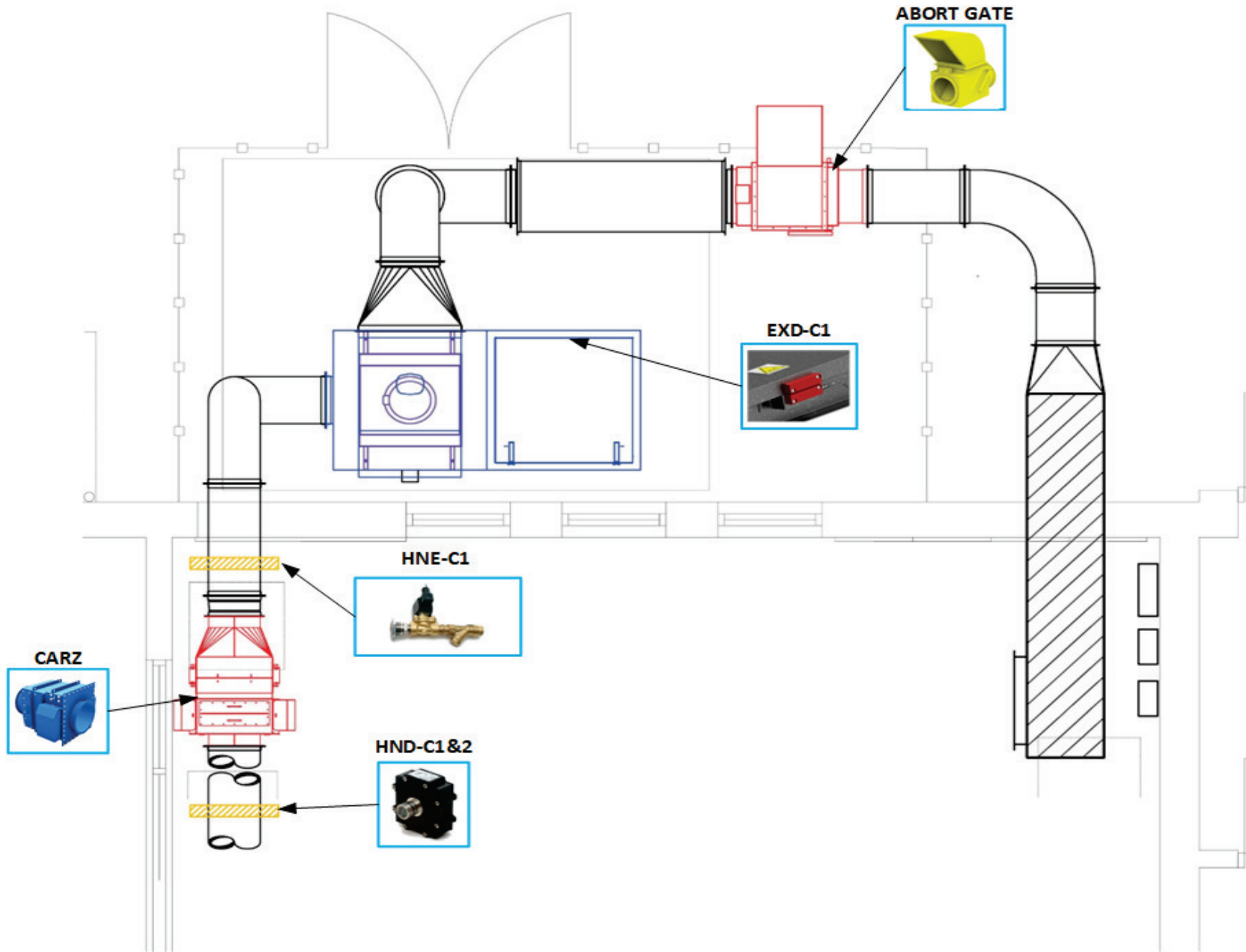

Sensors and device GA

CARZ Valve Control wiring diagram.

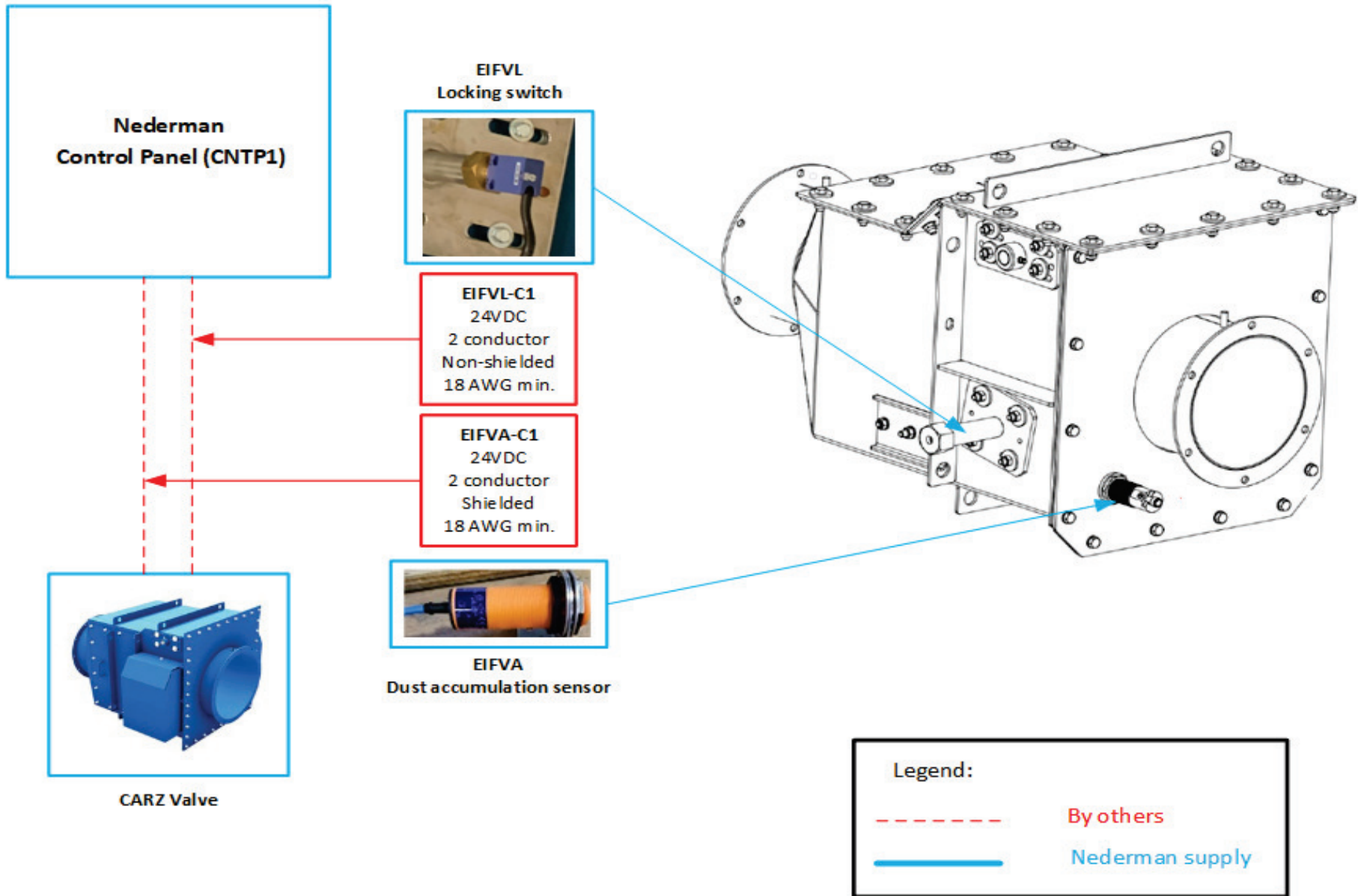

CARZ control wiring

Abort Gate Control wiring diagram.

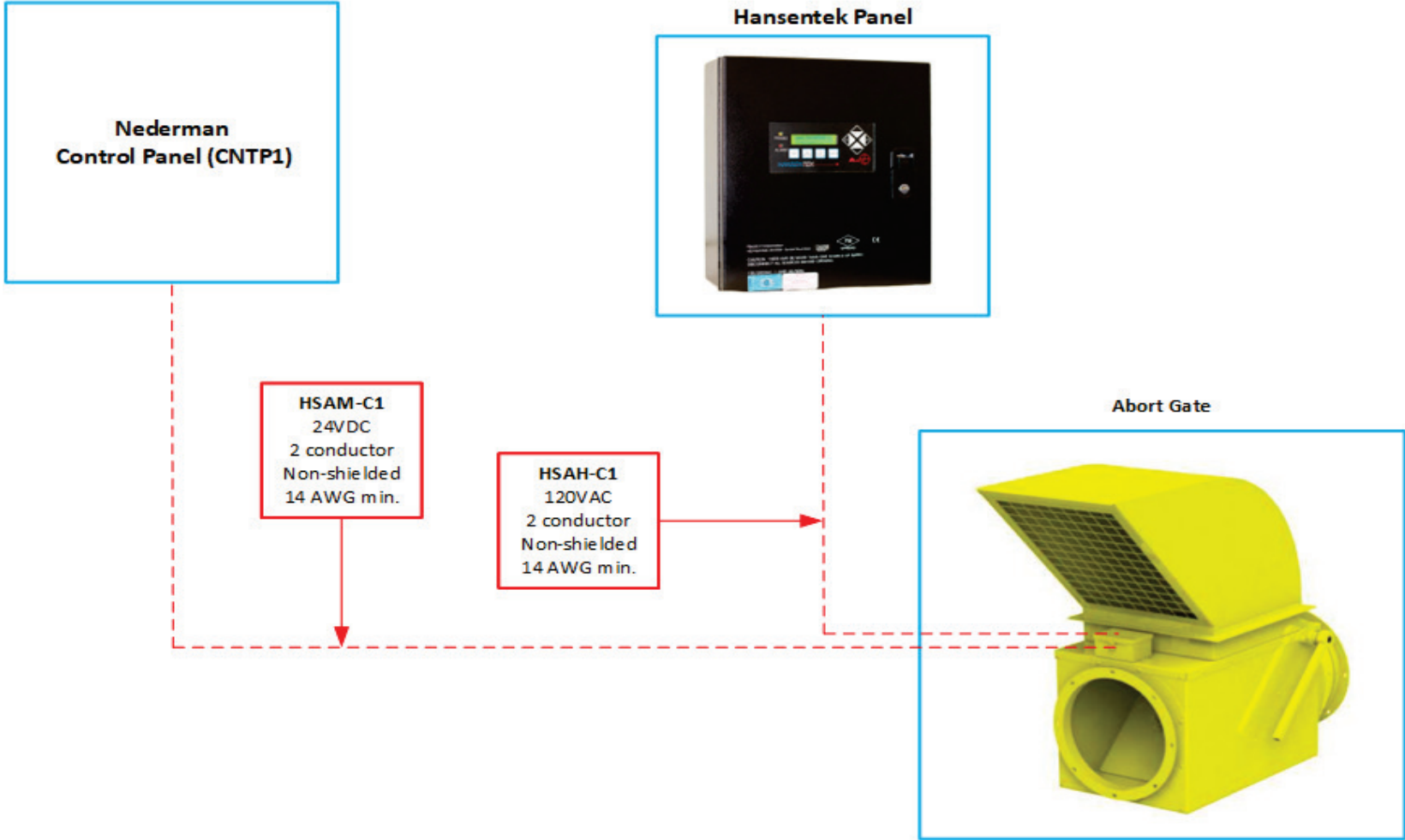

Legend:

- By others
- Nederman supply

Abort gate wiring

Hansentek Panel



Hansentek detector



24VDC
4 conductor
Shielded
18 AWG min.
Customer Supplied

Hansentek Control wiring diagram.

*Note: 120VAC and 24VDC shall be run in separate conduit

120VAC
2 conductor
Non-shielded
14 AWG min.
Customer supplied



Abort Gate

24VDC
4 Conductor
Non-shielded
14 AWG min.
Customer Supplied

Hansentek extinguishing system assembly w/ solenoid and flow switch

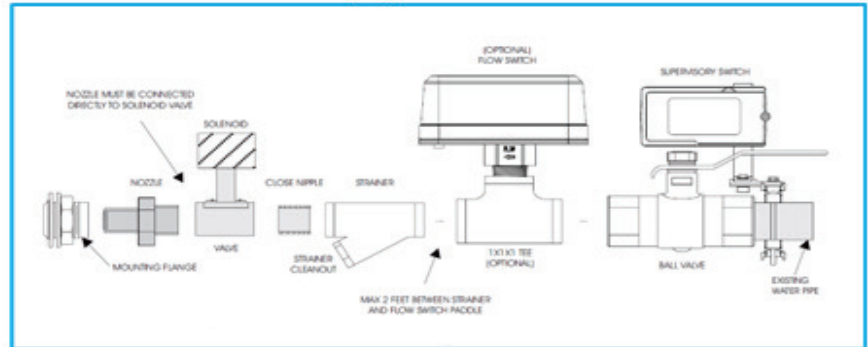

Legend:

- - - - - By others
- Nederman supply

Hansentek wiring

Sprinkler head and piping in NFZ/LBR series collector.

Each bag module (1200 x2400 mm - 3.9'x7.9') has a 25 GPM **tyco** series TY-B (TY3151 sprinkler head - upright - mounted on 1" MNPT pipe. 286 °F (blue) brass, K-5.6.

The pipe is extended through the collector wall for connection to sprinkler system provided by others.

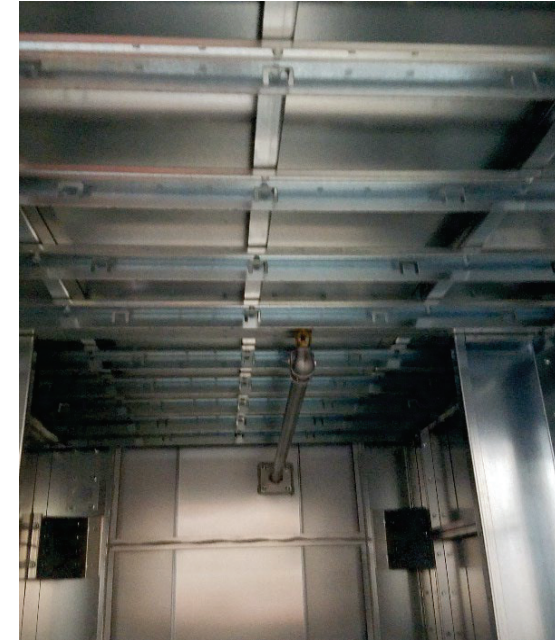
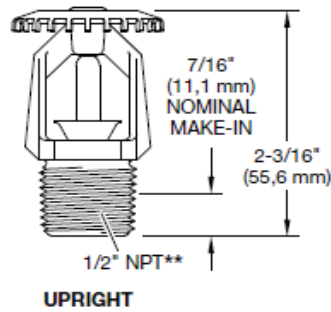

NFPA 664 has following requirement for sprinkler systems installed in collectors for the woodworking industry:

8.15 L/min/m² (0.20 gpm/ft²) over the horizontal projected area of the piece of equipment

For freeze protection the sprinkler system must be either a glycol or "dry" system installed in accordance with NFPA 13 - Standard for the Installation of Sprinkler Systems.

Sprinkler installation for NF/LBR series