



Addendum # 1
Bid Opportunity: 26-7851-RFT
Crestview Public School
RAAC Roof Deck Replacement/ Interior Alterations
Closing Date: Wednesday, April 1, 2026, 2:00 PM

The following issued by the Board shall form part of the Bid/ Proposal Solicitation document. The revisions and additions noted herein along with any attachments shall be read in conjunction with all other related documents. This Addendum shall take precedence over the previously issued documents where differences occur. Receipt of this addendum must be acknowledged in the Bidding System, bids & tenders.

If you have already submitted a Bid/ Proposal, it will be automatically withdrawn as a result of this addendum. You must resubmit the Bid/ Proposal acknowledging all addenda and revising your Bid/ Proposal to comply with all addenda.

1.1 QUESTIONS/ ANSWERS

Question 1:

Please provide Appendix 01 35 43B– Lead Report.

Answer 1:

Refer to Item 1.2.1 below.

Question 2:

Please provide a one-week extension to the tender closing date.

Answer 2:

An extension to the tender closing will not be considered at this time.

Question 3:

With respect to the roof work, can you please confirm whether the following proposed construction sequencing is acceptable and aligns with your expectations:

Phase 1: Removal of the existing roof system down to the RAAC deck, installation of a temporary vapour barrier over the entire surface, and demolition of existing parapets.

Phase 2: Removal of the temporary vapour barrier and RAAC decking in 400–500 sq ft sections, with a scaffold enclosure in place to prevent water infiltration, and installation of new structural components by others concurrent with deck removal.

Phase 3: Installation of new metal decking, thermal barrier, and vapour barrier following completion of the new structure; extension of the vapour barrier to the perimeter with a temporary loose flap to maintain watertightness until parapet reconstruction; completion of parapets, roof build-up, flashing, and tie-ins to adjacent existing roof areas.

Answer 3:

The Contractor is responsible for developing a work plan that maintains safety and the project schedule.

Question 4:

The Room Finish Schedule indicates that the existing floor finishes in Classroom 12 are to remain. However, due to the extent of plumbing work in this area, it is anticipated that the existing flooring may be disturbed or damaged during construction.

Please confirm the following:

1. Can we carry new resilient sheet flooring and rubber base in Classroom 12, consistent with the finishes specified for other classrooms? If not, please provide the specifications and requirements for patching and/or repair of the existing flooring.

Answer 4:

Demolition work in Classroom 12 is consistent with the scope of work noted for the other classrooms, as indicated on the Drawings. The existing resilient flooring and rubber base is removed as part of the work; however, no new flooring is to be installed at this time. Remove all adhesives and prepare the existing slab to receive a new floor finish in a future project phase.

Question 5:

Could you please confirm whether a separate quote is required for the exterior stair tower to provide access to the roof?

Answer 5:

The Contractor is to provide all construction facilities required for the completion of the project, as indicated in Specification Section 01 53 00.

Question 6:

Please confirm the intended roofing system for Roof Type R-1. The drawings indicate a 2-ply modified bitumen system, while the specifications call for a 3-ply built-up roofing system in cold adhesive with gravel surfacing. Clarify which system is to be provided

Answer 6:

The Specifications are correct. Refer also to Item 1.3.1 below; Drawing A1.01R has been revised to reflect this.

Question 7:

The Room Finish Schedule indicates that the existing floor finishes in the corridor are to remain. However, due to the extent of plumbing work in this area, it is anticipated that the existing flooring may be disturbed or damaged during construction. Please confirm what floor finish should be carried for the corridor. If patching is required, please provide the specification of the existing floor finish and any requirements for patching and/or repair.

Answer 7:

Refer to Items 1.2.2 and 1.3.2 below. Minimal subfloor removal is anticipated (refer to Mechanical Drawings).

Question 8:

Please confirm whether the existing refrigeration piping is to be retained or replaced, and if retained, provide the piping sizes and specifications.

Answer 8:

The existing refrigerant piping to be removed completely, as indicated on the Mechanical Drawings.

Question 9:

Please confirm whether the existing refrigerant within the condensing units is to be reused or replaced.

Answer 9:

Refer to Note 9 on Drawing M2.3, and Note 1 on Drawing M2.5.

Question 10:

Please provide specifications and requirements for refrigeration accessories, including isolation valves, filter driers, sight glasses, and solenoid valves.

Answer 10:

Refer to Specification Section 23 23 13, and related Specification Sections.

Question 11:

Please confirm whether the existing condensing unit stands are to be reused or replaced.

Answer 11:

Existing condensing unit stands may be reused. If reusing, stands are to be securely stored until they are reinstalled.

Question 12:

Please confirm the scope of work, including removal of the existing refrigerant, piping, and condensing units, followed by reinstallation after the roofing work is completed.

Answer 12:

Refer to Mechanical Drawings M2.3 and M2.5.

Question 13:

Please confirm who is responsible for storing and protecting the existing condensing units during the roofing phase.

Answer 13:

The mechanical contractor is responsible for storing and protecting all mechanical equipment until reinstallation is complete.

Question 14:

During the site walkthrough, it was mentioned that we need to consider storage for all items that will be reused. Could you please confirm this and specify which items need to be stored?

Answer 14:

Yes, all items to be reused/ reinstalled are to be securely stored. Refer to the Drawings for fittings and equipment that needs to be temporarily removed/ stored.

Question 15:

Can we use the existing bathroom, or do we need to provide temporary facilities during construction?

Answer 15:

Refer to Specification Section 01 53 00. The use of existing washroom facilities is not permitted.

Question 16:

Please provide the location for garbage disposal during construction.

Answer 16:

The location for garbage disposal will be identified with the successful Contractor.

Question 17:

Please clarify how the electrical connections will be coordinated in this renovation, considering that another contractor is already performing electrical work in a different area of the school. Specifically, please confirm where the connection point for our scope will be and how the tie-in between the existing system and our area of work will be coordinated.

Answer 17:

The work of the Contractor currently on site will be complete prior to the commencement of this Contract.

Question 18:

Please provide clarification on the refrigerant piping scope, as it is not clear which piping is to remain and which is to be replaced. Additionally, please confirm the required pipe sizes and provide further details regarding the piping components, including solenoid valves, filter driers, sight glasses, and isolation valves.

Answer 18:

Refer to the responses to Questions 10 and 12.

Question 19:

Could you please provide the attendance list from the site walkthrough?

Answer 19:

The list is not being issued.

Question 20:

Can you please confirm that the WRDSB will provide a location to store the existing millwork and unit ventilators?

Answer 20:

The Contractor is responsible for providing secure and weathertight storage for all equipment to be reused/ reinstalled.

Question 21:

The Room Finish Schedule indicates that the existing floor finishes in the boys' and girls' washrooms are to remain. However, due to the extent of plumbing work required, it is anticipated that the existing floor finishes in these areas will be significantly disturbed or damaged during construction.

Please confirm the following:

1. Should new floor finishes be carried for these washrooms?

2. If new finishes are required, please provide the applicable specifications.
3. If the intent is to retain existing finishes, please provide the specifications and requirements for patching and/or repair of the existing flooring.

Answer 21:

The existing floor finishes in the Existing Boy's and Girl's Washrooms are to be protected during construction. No floor cutting has been identified in this area, and all removal work is above the existing ceiling.

Question 22:

Can you please confirm whether the use of Hilti fasteners to secure the metal decking, in lieu of puddle welding, would be acceptable?

Answer 22:

The use of Hilti X-ENP 19 metal deck fasteners is an acceptable alternate to puddle welding.

Question 23:

Will alternates be considered for Section 07 46 13 – Preformed Metal Siding?

Answer 23:

At this time, the specification for Section 07 46 13 remains unchanged, to ensure material and colour consistency with the project currently being completed on the same building.

1.2 ARCHITECTURAL SPECIFICATIONS

- .1 Appendix 01 34 43B Lead Report
 - .1 REPLACE Appendix 01 34 43B with Appendix 01 34 43B - R (52 pages), attached.
- .2 Section 09 66 13 Epoxy Bonded Portland Cement Terrazzo
 - .1 ADD Section 09 66 13 (2 pages), attached.

1.3 ARCHITECTURAL DRAWINGS

.1 Drawing A1.01 OBC Data, Building Elements, Overall Site Plan, &
General Notes

.1 **REPLACE DRAWING A1.01 WITH DRAWING A1.01R,
ATTACHED.**

END OF ADDENDUM #1

+ Appendix 01 34 43B - R (52 pages), Section 09 66 13 (2 pages)
Drawing A1.01R.

Appendix 01 35 43B– Lead Report



PROJECT-SPECIFIC DESIGNATED SUBSTANCE & HAZARDOUS MATERIALS ASSESSMENT

Crestview Public School
153 Montcalm Drive,
Kitchener, Ontario

Prepared for:
Daniela Budure,
Environmental Officer

Waterloo Region District School Board
51 Ardel Avenue
Kitchener, Ontario N2C 2R5

Prepared by:
Safetech Environmental Limited

Per: Alyssa Nagy, B.Sc.,
Occupational Health & Safety Technician

Per: Shannon Deline, B.A.,
Project Coordinator

Reviewed by: Jeremy J. Gore, C.E.T., EP
Regional Manager – SWO

Safetech Project Number 2-3250018

TABLE OF CONTENTS

EXECUTIVE SUMMARY	i
1.0 INTRODUCTION	1
1.1 Background and Objectives	1
1.2 Scope of Work.....	2
1.3 Past Environmental Reports.....	2
2.0 METHODOLOGY	3
2.1 Designated Substances	4
2.1.1 Asbestos.....	4
2.1.2 Lead	5
2.1.3 Mercury	6
2.1.4 Silica.....	6
2.1.5 Other Designated Substances	6
2.2 Other Hazardous Materials	6
2.2.1 Chemical Hazards	6
2.2.2 Biological Hazards.....	7
2.2.3 Environmental Hazards	7
3.0 RESULTS.....	8
3.1 Designated Substances	8
3.1.1 Asbestos.....	8
3.1.2 Lead	11
3.1.3 Mercury	12
3.1.4 Silica.....	12
3.1.5 Other Designated Substances	13
3.2 Other Hazardous Materials	13
3.2.1 Chemical Hazards	13
3.2.2 Biological Hazards.....	13
3.2.3 Environmental Hazards	13

4.0	CONCLUSIONS AND RECOMMENDATIONS	14
4.1	Designated Substances	14
4.1.1	<i>Asbestos</i>	14
4.1.2	<i>Lead</i>	15
4.1.3	<i>Mercury</i>	16
4.1.4	<i>Silica</i>	16
4.1.5	<i>Other Designated Substances</i>	17
4.2	Other Hazardous Materials	17
4.2.1	<i>Chemical Hazards</i>	17
4.2.2	<i>Biological Hazards</i>	17
4.2.3	<i>Environmental Hazards</i>	17
5.0	Limitations	18

LIST OF TABLES

Table 1	Bulk Sample Analytical Results for Determination of Asbestos Content
Table 2	Results of Assessment for Asbestos-Containing Materials
Table 3	Results of Paint Condition and Lead Content Assessment

LIST OF APPENDICES

Appendix A	Condition Assessment Criteria for Asbestos-Containing Materials
Appendix B	Figure AS01: Extent of Assessment Area and Sample Locations
Appendix C	Laboratory Certificates of Analysis – Asbestos and Lead
Appendix D	Site Photographs – February 28, 2025
Appendix E	Background Information on Designated Substances and Other Hazardous Materials

EXECUTIVE SUMMARY

Safetech Environmental Limited (Safetech) was retained by the Waterloo Region District School Board (WRDSB), to conduct a project-specific designated substance and hazardous materials (DSHM) assessment in preparation of upcoming renovation work within Crestview Public School located at 153 Montcalm Drive, in Kitchener, Ontario. The building will herein be referred to as the “site” and the areas assessed will be referred to as the “project-specific assessment area”.

The objective of our assessment was to determine the presence, location, condition, and approximate quantities (where possible) of designated substances and other hazardous materials within project-specific assessment areas that have the potential to be disturbed as part of upcoming renovation activities so that appropriate abatement and other control measures can be implemented to protect workers during work and control/classify waste materials, as mandated by Ontario regulations. It is Safetech’s understanding that the proposed renovation work includes select wall demolition as well as floor, wall and ceiling finish upgrades within the project-specific work areas as identified by marked-up floor plans provided by the Waterloo Region District School Board.

A summary of the designated substances and hazardous materials identified is provided below. This should be considered a summary only. Please refer to the Results (Section 3) and Conclusions and Recommendations (Section 4) of our report for additional details.

Asbestos

Asbestos was confirmed present within the following building materials observed within project-specific assessment area:

- Parging cement on mechanical pipe fittings above lay-in ceilings in corridor 802 (lobby), room 102 (copy room), room 103 (office), and room 138 (storage);
- 9”x9” beige with brown streak vinyl floor tiles within rooms 137 (work room) and 138 (storage);
- Black mastic associated with floor tiles throughout the original building;
- White exterior caulking at windows of the original building; and,
- Gold acoustic sink coat on the underside of two (2) sinks within room 106 (staff room).

No other asbestos-containing materials were identified or are suspected present within the project-specific assessment area. This assessment was limited to sampling of materials that have the potential to be impacted by planned renovation work, as reported by the WRDSB. Assessment of other areas or materials within the building was not conducted. Asbestos-containing materials and other designated substances are present in other areas of the building, which are not identified in this report. If the scope of work expands beyond the limit of our assessment then stop work and assess, as needed. Refer to Figure AS01 in Appendix B for the extent of this assessment.

Lead

Results of paint chip analysis for the determination of lead content indicated that all paints collected for analysis were found to have a '*de minimis*' or 'virtually safe' level of lead in paint in accordance with the Environmental Abatement Council of Canada (EACC) "Lead Guideline" (October 2014).

Lead is also suspected present in minor quantities as solder in pipe fittings and electrical equipment. Any disturbance of lead materials should be conducted in accordance with the procedures outlined in the EACC "Lead Guideline" (October 2014) and the Ministry of Labour, Immigration, Training and Skills Development (MLITSD) "Lead on Construction Projects" guideline (April 2011). The extent of procedures required depends on the type of work to be conducted.

Mercury

Mercury is deemed present in the form of mercury vapour within sealed fluorescent lamps. Lamps should be handled with care and kept intact to avoid potential exposure to mercury. R.R.O 1990 Regulation 347, waste mercury produced in amounts less than 5 kilograms (kg) are exempt from hazardous waste registration, treatment and disposal requirements and can be disposed of in landfill as regular waste.

Silica

Silica is deemed present in drywall and associated joint compounds, lay-in acoustic ceiling tiles, caulking, mastics, ceramic tiles and grout, block and associated mortar, and all concrete materials and finishes. Work involving the disturbance of silica-containing materials should follow the procedures outlined in the MLITSD "Silica on Construction Projects" Guideline (April 2011). The appropriate engineering controls, work practices, hygiene practices, personal protective measures and training necessary to conduct the work in a safe manner are provided in this guideline.

This assessment satisfies the Owner's requirements under Section 30 of the Ontario Occupational Health and Safety Act (OHSA), Revised Statutes of Ontario 1990, as amended.



Should you have any questions regarding the information contained in the report, please contact our office at 519.954.2732.

Safetech Environmental Limited

Per: Alyssa Nagy, B.Sc.,
Occupational Health & Safety Technician
anagy@safetechenv.com

Per: Shannon Deline, B.A.
Project Coordinator
sdeline@safetechenv.com

Reviewer: Jeremy J. Gore, C.E.T., EP
Regional Manager – SWO
jgore@safetechenv.com

March 14, 2025

Waterloo Region District School Board

51 Ardelt Avenue
Kitchener, Ontario N2C 2R5

Attention: Daniela Budure,
Environmental Officer
daniela_budure@wrdsb.ca

**RE: Project-Specific Designated Substance & Hazardous Materials Assessment
Crestview Public School
153 Montcalm Drive, Kitchener, Ontario**

1.0 INTRODUCTION

1.1 Background and Objectives

Safetech Environmental Limited (Safetech) was retained by Daniela Budure with the Waterloo Region District School Board (WRDSB), to conduct a project-specific designated substance and hazardous materials (DSHM) assessment in preparation of upcoming renovation work within Crestview Public School located at 153 Montcalm Drive, in Kitchener, Ontario (site). The objective of our assessment was to determine the presence, location, condition and approximate quantities of designated substances and other hazardous materials within project-specific assessment areas that have the potential to be disturbed as part of upcoming renovation activities so that appropriate abatement and other control measures can be implemented to protect workers during work and control/classify waste materials, as mandated by Ontario regulations.

This assessment satisfies the requirements under Section 30 of the Ontario Occupational Health and Safety Act (OHSA), Revised Statutes of Ontario 1990, as amended. Section 30(1) requires an assessment to determine if there are any designated substances present at a project site prior to construction or demolition activity. Sections 30(2), (3) and (4) require the constructor for a project to provide the findings in this report as part of the tendering information for any tendered project or to prospective contractors (and subcontractors) of a project before entering into a binding contract.

This report documents the findings of our on-site inspection that was conducted on February 28, 2025, and provides conclusions and recommendations based on our findings and knowledge of the planned renovation project.

1.2 Scope of Work

Our scope of work included the following activities:

- A review of existing environmental assessment report(s) provided by WRDSB.
- A visual assessment of all project areas specific to the renovation project to identify the presence, location, condition and approximate quantities of designated substances and other hazardous building materials that may be present. The extent of our assessment area was defined by floor plans provided by WRDSB on February 10, 2025.
- Collection, analysis and interpretation of representative bulk samples of suspect asbestos-containing building materials for the determination of asbestos content and material classification (limited to the project-specific assessment areas) only where deemed necessary if a data gap was identified by past environmental reports or a material was noted that does not match a reported description.
- Collection, analysis and interpretation of representative paint chip samples of suspect lead-containing paint for the determination of lead content and material classification (limited to the project-specific assessment areas).
- Preparation of a report to document findings and provide recommendations regarding control measures and/or special handling procedures for designated substances or specific hazardous materials that may be removed or disturbed as part of planned renovation activities.

This assessment only identified designated substances and hazardous materials that were deemed to be part of the building or somehow otherwise incorporated into the building structure and its finishes. Assessing occupant items such as stored products, furnishings, and items, etc., were beyond the scope of this assessment. In addition, our assessment did not include an investigation for underground materials or equipment (vessels, drums, underground storage tanks, pipes, cables, etc.). Furthermore, this assessment was limited to the areas investigated, and more specifically, to those materials that are readily accessible without demolition or alteration of building components for access.

1.3 Past Environmental Reports

Data from past environmental surveys was referenced in terms of understanding previous assessment results and obtaining a general understanding of the overall asbestos-containing material conditions. Where possible, Safetech relied upon results indicated in past surveys and only collected confirmatory samples as necessary.

The following environmental report was provided to Safetech:

- ‘2024 Asbestos Audit Update Report – Crestview Public School, 153 Montcalm Drive, Kitchener, Ontario’ completed by MTE Consultants, dated January 25, 2024.

Based on our review of the previous asbestos reassessment report, the following asbestos-containing materials are present within the project-specific work areas:

- Parging cement on mechanical pipe fittings.
- 9”x9” beige with brown streak vinyl floor tiles.
- Mastic associated with floor tiles throughout the original building.
- White window glazing at windows of the original building.

2.0 METHODOLOGY

The presence of hazardous materials was assessed by visual inspection. For the purpose of this assessment and this document, hazardous materials include designated substances as well as other chemical, biological and environmental hazards as defined below:

- **Designated Substances (as prescribed by Ontario Regulation 490/09):**
 - Acrylonitrile, Arsenic, Asbestos, Benzene, Coke Oven Emissions, Ethylene Oxide, Isocyanates, Lead, Mercury, Silica and Vinyl Chloride.
- **Other Hazardous Materials:**
 - **Chemical Hazards** – Urea Formaldehyde Foam Insulation (UFFI) and other obvious potential chemical hazards
 - **Biological Hazards** – Mould Contamination
 - **Environmental Hazards** – Polychlorinated Biphenyls (PCBs) and Ozone Depleting & Global Warming Substances

For background information regarding the above hazardous materials, please refer to Appendix E.

Destructive testing was not conducted as part of this assessment. Concealed locations such as above solid ceilings, within wall cavities, enclosed mechanical/pipe shafts and bulkheads, etc. were not investigated. Similarly, motors, blowers, electrical panels, etc., were not de-energized or disassembled to examine concealed conditions. Building materials that are not detailed within this assessment due to inaccessibility at the time of our site visit and/or uncovered during renovation activities should be assessed by a qualified person prior to their disturbance.

Bulk sampling followed by laboratory analysis was also conducted to confirm the presence/absence of selected hazardous materials. Bulk sampling was limited to asbestos in building materials and lead in paint. All other hazardous materials were identified by visual inspection only.

Where possible, observations regarding the location, quantity and condition of the hazardous materials identified were made in order to determine the potential for exposure and provide appropriate recommendations for remedial action, if necessary. Specific methodology for each individual hazardous material assessed is further detailed below.

2.1 Designated Substances

2.1.1 Asbestos

A visual inspection for the presence of both friable and non-friable asbestos-containing material (ACM) was performed within the assessment area. The condition of ACM was rated as Good, Fair or Poor based on our assessment criteria provided in Appendix A.

Although destructive testing was not conducted, details regarding the possible presence of ACM in enclosed locations were provided on a case-by-case basis where our visual inspection indicated this possibility. Materials that may be present in the surveyed area(s) that were not tested intrusively should be considered asbestos-containing until proven otherwise. This includes materials such as elevator brakes, roofing felts, mastics, high voltage wiring, mechanical packing and gaskets, vermiculite inside wall cavities or inaccessible ceiling spaces, and underground services or piping. These materials are recommended to be sampled immediately prior to renovation work if they are to be removed or have a potential to be disturbed.

Bulk samples of building materials were retrieved for all accessible building materials within the investigated areas that were suspected to be asbestos-containing, based on the historical use of the material and surveyor knowledge and experience. Bulk samples were retrieved in accordance with Section 3 and Table 1 of Ontario Regulation 278/05, *Designated Substance – Asbestos on Construction Projects and in Buildings and Repair Operations (O. Reg. 278/05)*, made under the Occupational Health and Safety Act. The number of samples collected for each material was based on the type and quantity of the material present within the area(s) investigated.

Each individual sample was placed in a labelled, sealable, plastic bag for transportation to an independent laboratory (EMC Scientific Inc.). EMC Scientific Inc. is accredited by the National Voluntary Laboratory Accreditation Program (NVLAP) for bulk asbestos fibre analysis. Analysis for asbestos content was performed by the independent laboratory in accordance with the U.S. Environmental Protection Agency (EPA) Test Method EPA/600/R-93-116: Method for the Determination of Asbestos in Bulk Building Materials. June 1993.

This method identifies the asbestos fibre content of building materials using polarized light microscopy (PLM) analytical techniques, with confirmation of presence and type of asbestos made by dispersion staining optical microscopy. This analytical method meets the requirements set forth in Section 3 of O. Reg. 278/05.

In accordance with O. Reg. 278/05, an asbestos-containing material is defined as material that contains 0.5 per cent or more asbestos by dry weight. The laboratory was instructed to conduct “stop-positive” analysis for all materials. If a sample was found to be asbestos-containing no further analysis was conducted for samples taken from the same homogeneous material. The Laboratory Certificate of Analysis is included in Appendix C. Locations where ACM have been identified are detailed in this report. Recommendations pertaining to ACM were made based on the friability, accessibility, and condition of the material.

2.1.2 Lead

An assessment for lead in paint was conducted by retrieving paint chip samples from representative surfaces within the areas assessed. The condition of the painted surface from which each sample was taken was also visually assessed for signs of deterioration such as cracking, chipping, flaking, bubbling and deterioration due to friction. The condition of these surfaces were assessed as good, fair or poor based on the degree and extent of deterioration. The paint chip sample was retrieved by scraping the paint down to the base material substrate to ensure collection of all layers of paint. Care was taken to avoid collection of the underlying substrate to reduce analytical substrate matrix interference.

Upon completion of our assessment, the paint chip samples were submitted to an independent laboratory (Caduceon Environmental Laboratories) for the determination of lead content. This laboratory participates in and is accredited by the EPA (U.S. Environmental Protection Agency) for analysis of lead in paint chips through the American Industrial Hygiene Association (AIHA) Environmental Lead Laboratory Accreditation Program (ELLAP). Analysis was conducted by the laboratory following the EPA Method 6010. Result of analysis was reported by the laboratory in micrograms per gram ($\mu\text{g/g}$). The Laboratory Certificate of Analysis is included in Appendix C.

The presence of lead in other materials, such as lead sheeting, pigmented mortar, lead piping, lead solder, etc. were noted where observed but were not sampled to verify lead content. Lead can be present in these materials to varying degrees, depending on their age of application (refer to Appendix E for additional details) and should be considered lead-containing until proven otherwise.

2.1.3 Mercury

The type, quantity, and location of mercury-containing equipment and devices within the areas assessed were determined by visual inspection based on appearance, age and knowledge of historical uses. Sampling for mercury-containing building materials and dismantling of suspect mercury-containing equipment was not performed. Where possible, attempts were made to verify the presence/absence of mercury by gathering additional information such as equipment model number, serial number, etc.

2.1.4 Silica

The presence of crystalline silica in building materials was determined through visual inspection of building materials only, based on knowledge of the historic use of silica-containing materials in certain building materials. Sampling to verify the presence/absence of silica in building materials was not performed.

2.1.5 Other Designated Substances

Other designated substances (i.e. acrylonitrile, arsenic, benzene, coke oven emissions, ethylene oxide, isocyanates, and vinyl chloride) are typically not expected to be encountered in building materials as significant constituents or in a form that would represent an exposure concern. These substances were not included in our assessment unless specific information regarding their use (e.g. in a manufacturing process) was provided to us. Please refer to Appendix E for information regarding where these designated substances are typically found or used. No sampling for these designated substances was performed.

2.2 Other Hazardous Materials

2.2.1 Chemical Hazards

Urea Formaldehyde Foam Insulation (UFFI)

A visual inspection to evaluate the possible presence of Urea Formaldehyde Foam Insulation (UFFI) was conducted within the area(s) assessed. Our visual inspection was limited to looking for evidence of possible UFFI installation (i.e. repaired nozzle holes in walls) and overspray at wall/ceiling joints, etc. No material sampling was conducted as part of our assessment.

2.2.2 Biological Hazards

Mould Contamination

A visual inspection to determine the possibility of indoor mould growth was conducted within the area assessed. Our assessment was limited to looking for evidence of mould growth and water damage (staining, material deterioration, efflorescence, etc.) on the surface of building materials, which may be an indicator of hidden mould growth. No moisture content readings of building materials were taken to determine their current condition. Additionally, destructive testing to confirm the presence/absence of hidden mould growth and material sampling to verify the presence/absence of mould on suspect surfaces was beyond the scope of this assessment.

2.2.3 Environmental Hazards

Polychlorinated Biphenyls (PCBs)

The presence of PCB-containing electrical equipment within the area(s) assessed was identified through visual inspection and knowledge of the timeline of historical use.

For stand-alone transformers and capacitors, information from the manufacturer nameplate (such as the date of manufacture, dielectric fluid trade name or “Type Number”, etc.) was gathered, where possible, to further evaluate if the equipment may contain PCBs. This information was then compared to the information provided in the Environment Canada document entitled “*Handbook on PCB’s in Electrical Equipment*” (Third Edition, April 1988) to aid in identification. Transformers and capacitors confirmed to be manufactured after 1979 were assumed to not contain PCBs. If appropriate information could not be obtained it was assumed that the transformer or capacitor contained PCBs.

No sampling of materials or fluids within equipment was conducted to verify the presence/absence of PCBs. Inspection and testing of other materials for PCB content, including (but not limited to) caulking, asphalt, oil-based paint, plastics, switches, oil residue, electric cables and hydraulic fluids was beyond the scope of our assessment.

Ozone Depleting and Global Warming Substances

The presence of fixed equipment likely to contain ozone-depleting substances (ODS) and/or global-warming substances (GWS) was identified through visual inspection and knowledge of the timeline of historical use. This included equipment such as chillers, air-conditioners and fixed dry-chemical fire extinguishers, where chemicals such as hydrochlorofluorocarbons (HCFCs), hydrofluorocarbons (HFCs) or halons may be present. Where possible, information regarding the type and quantity of refrigerant present was obtained from the manufacturer nameplate.

Our visual assessment was limited to fixed equipment within the area(s) assessed and did not include portable equipment such as stand-alone refrigerators, freezers, water coolers, air-conditioners and fire extinguishers, etc.

3.0 RESULTS

Results of our visual assessment and bulk sample analytical findings are summarized in the sections below. Photographs of conditions observed are referenced in the appropriate section where applicable (as **P#**) and are included in Appendix D.

3.1 Designated Substances

3.1.1 Asbestos

Results of bulk sample analysis for the determination of asbestos content are summarized in Table 1. Materials have been classified as “ACM” or “Non-ACM” based on analytical results. Please refer to the Limitations section of this report (Section 5.0) for additional details. The Laboratory Certificate of Analysis is included in Appendix C.

TABLE 1
Bulk Sample Analytical Results for Determination of Asbestos Content
Crestview Public School - 153 Montcalm Drive, Kitchener, Ontario
Sample Collection Date: February 28, 2025

Sample No.	Material Description	Sample Location	Asbestos Content	Material Classification
S01A	Caulking at Concrete Deck Joints	Room 101 (Office)	None Detected	Non-ACM
S01B				
S01C				
S02A	Gold Acoustic Sink Coat	Room 106 (Staff Room)	3% Chrysotile	ACM
S02B			Not Analyzed	
S02C				

¹ As per O. Reg. 278/05, ACM contains $\geq 0.5\%$ asbestos by dry weight.

² Not Analyzed = Not analyzed due to positive asbestos result in previous sample.

Materials assessed for asbestos content are summarized in Table 2 based on the type/use of the material. The condition and friability of materials confirmed or suspected to be asbestos-containing (based on our visual assessment and results of bulk sample analysis) is provided. Condition (Cond.) ratings are provided as Good (G), Fair (F) or Poor (P) based on our Assessment Criteria provided in Appendix A. Estimates of quantity have only been provided for confirmed or suspected asbestos-containing materials that were deemed to have a potential to be disturbed as part of the upcoming renovation project. Any quantities provided should be considered rough estimates only and only apply to the limited project-specific assessment areas.

TABLE 2
Results of Assessment for Asbestos-Containing Materials
Crestview Public School - 153 Montcalm Drive, Kitchener, Ontario
Date of Assessment: February 28, 2025

Sprayed and Loose Fill Insulating Materials	Location/Description	Cond.	Est. Quantity	Friability
Sprayed Fireproofing	None identified in project-specific work areas.	N/A	N/A	N/A
Sprayed Insulation	None identified in project-specific work areas.	N/A	N/A	N/A
Loose Fill / Vermiculite Insulation	None identified in project-specific work areas.	N/A	N/A	N/A
Thermal System Insulation	Location/Description	Cond.	Est. Quantity	Friability
Mechanical Pipe Insulation – Straights	Mechanical pipe straights within the areas assessed were observed to be uninsulated or insulated with non-asbestos fibreglass. No asbestos-containing pipe straight insulation was identified within project-specific work areas.	N/D	N/D	N/D
Mechanical Pipe Insulation – Fittings (elbows, valves, tees, hangars, etc.)	Parging cement in good condition was identified on mechanical pipe fittings above lay-in ceilings throughout the areas assessed. The material was sampled during a previous environmental survey and was determined to be asbestos-containing (refer to the report referenced in Section 1.3). Additional asbestos-containing parged pipe fittings may be present within concealed locations of project-specific work areas (i.e. above solid ceilings, enclosed wall cavities, etc.).	Good	~27	Friable
	Asbestos-containing parging cement on mechanical pipe fittings were identified to be in FAIR condition above lay-in ceilings in corridor 802 (lobby) (P1).	Fair	~4	Friable
	Asbestos-containing parging cement on mechanical pipe fittings were identified to be in POOR condition above lay-in ceilings in corridor 802 (lobby) (P2).	Poor	~4	Friable
HVAC Duct Insulation	HVAC ducting within the assessed areas were observed to be uninsulated.	N/A	N/A	N/A
Breeching / Exhaust Insulation	None identified in project-specific work areas.	N/A	N/A	N/A
Tank Insulation	None identified in project-specific work areas.	N/A	N/A	N/A
Boiler Insulation	None identified in project-specific work areas.	N/A	N/A	N/A

Architectural Finishes & Finishing Materials	Location/Description	Cond.	Est. Quantity	Friability
Sprayed Texture / Stucco Finishes	Hard stippled texture finish was identified on the concrete deck within rooms 141 and 142. This material was installed during the post 1990 building addition, and is not suspected of containing asbestos.	N/A	N/A	N/A
Plaster Finishes	None identified in project-specific work areas.	N/A	N/A	N/A
Drywall Joint Compound	Drywall finishes were identified throughout the project-specific work areas. The material was sampled during a previous environmental survey and was determined not to contain asbestos (refer to the report referenced in Section 1.3).	N/A	N/A	N/A
Ceiling Tiles	Location/Description	Cond.	Est. Quantity	Friability
Lay-In Acoustic Ceiling Tiles	2'x4' deep fissure and random pinhole patterned ceiling tiles were identified throughout the project-specific areas assessed. The material was sampled during a previous environmental survey and was determined not to contain asbestos (refer to the report referenced in Section 1.3).	N/A	N/A	N/A
	2'x4' Short fissure and random pinhole patterned ceiling tiles were identified throughout the project-specific areas assessed. The tiles contained manufacturer's stamps indicating they were manufactured in 2010 when asbestos was no longer in use for this material.	N/A	N/A	N/A
Fixed-in-Place Ceiling Tiles	None identified in project-specific work areas.	N/A	N/A	N/A
Flooring	Location/Description	Cond.	Est. Quantity	Friability
Vinyl Floor Tiles	9"x9" beige with brown streak vinyl floor tiles were identified within rooms 137 (work room) and 138 (storage) (P3). The tiles were sampled during a previous environmental survey and was determined to contain Chrysotile asbestos (refer to the report referenced in Section 1.3).	Good	~ 15m²	Non-Friable
	12"x12" beige mottled vinyl floor tiles were identified throughout the project-specific work areas. The material was sampled during a previous environmental survey and was determined not to contain asbestos (refer to the report referenced in Section 1.3).	N/A	N/A	N/A
Vinyl Sheet Flooring	Grey vinyl sheet flooring was identified in rooms 101, 102, 103, and 104 (offices). This material was visually assessed and noted to be heat sealed with no paper backing; it is therefore not suspected of containing asbestos.	N/A	N/A	N/A

Floor Tile Mastic	Black mastic associated with vinyl floor tiles was identified within the original building. This material was sampled during a previous environmental survey and was determined to contain Chrysotile asbestos (refer to the report referenced in Section 1.3).	Good	~30m²	Non-Friable
Asbestos Cement Products	Location/Description	Cond.	Est. Quantity	Friability
Piping	None identified in project-specific work areas.	N/A	N/A	N/A
Roofing, Siding, Wallboard	None identified in project-specific work areas.	N/A	N/A	N/A
Other Cement Products	None identified in project-specific work areas.	N/A	N/A	N/A
Misc. Materials	Location/Description	Cond.	Est. Quantity	Friability
Caulking/ Glazing Putty	White exterior caulking was identified at windows of the original building, including the offices and the staff room. This material was sampled during a previous environmental survey and was determined to contain Chrysotile asbestos (refer to the report referenced in Section 1.3).	Good	ND	Non-Friable
	Grey caulking was identified at concrete deck seams throughout the original building (P3). This material was sampled and determined to not contain asbestos (refer to sample S01 in Table 1).	N/A	N/A	N/A
Acoustic Sink Coat	Gold acoustic sink coat was identified on the underside of two (2) sinks in room 106 (staff room) (P4). This material was sampled and determined to contain 1% Chrysotile asbestos (refer to sample S02 in Table 1)	Good	2 Sinks	Non-friable

Notes: N/A=Not Applicable; N/D=Not Determined

3.1.2 Lead

Laboratory analytical results for paints and surface coatings tested to determine lead content are summarized below in Table 3. The Laboratory Certificate of Analysis is included in Appendix C.

TABLE 3
Results of Paint Condition and Lead Content Assessment
153 Montcalm Drive, Kitchener, Ontario
Sample Collection Date: February 28, 2025

Sample No.	Location	Surface	Paint Colour	Condition	Lead Conc. (µg/g)	EACC Classification
LP01	Corridor 802	Concrete Block Wall	Cream	Good	23	'de-minimis' level of lead
LP02	Room 107	Concrete Block Wall	Light Grey	Good	199	'de-minimis' level of lead
LP03	Room 101	Concrete Deck	White	Good	272	'de-minimis' level of lead
LP04	Room 137	Concrete Block Wall	Lime Green	Good	95	'de-minimis' level of lead

Paint samples below 1000 µg/g are considered 'de minimis' or 'virtually safe' level of lead as per the October 2014 EACC Lead Guideline for Construction, Renovation, Maintenance or Repair. All paint samples collected for lead content analysis within the areas assessed were determined to contain 'de minimis' level of lead. Materials coated with 'de minimis' level of lead paints do not require special procedures when performing work that may disturb them or their coatings.

Additional minor lead-containing materials suspected present within the investigated area include the following:

- Lead solder used in pipe fittings or electrical equipment.

3.1.3 Mercury

Mercury is deemed present in vapour form within fluorescent light tubes located throughout the areas assessed. No other equipment suspected of containing mercury was identified within the assessed areas.

3.1.4 Silica

A number of building materials were identified within the surveyed areas that are suspected to contain crystalline silica. This includes the following materials:

- Drywall and associated joint compounds;
- Lay-in acoustic ceiling tiles;
- Caulking;
- Mastics;

- Brick and associated mortar; and,
- All concrete finishes and materials.

3.1.5 Other Designated Substances

Acrylonitrile, arsenic, benzene, coke oven emissions, ethylene oxide, isocyanates, and vinyl chloride were not included in our assessment as these substances are not expected to be a significant component of building materials or present in a form that would represent an exposure concern. Additionally, no specific information regarding their use was provided to us.

3.2 Other Hazardous Materials

3.2.1 Chemical Hazards

No visible evidence of UFFI installation (i.e. injection openings) or overspray of foam insulation at wall/ceiling joints was identified. In addition, UFFI insulation within interior wall cavities is not suspected. No other hazardous materials were identified nor are they suspected present.

3.2.2 Biological Hazards

Mould Contamination

No areas of water damage or mould growth were identified within the surveyed area(s).

3.2.3 Environmental Hazards

Polychlorinated Biphenyls (PCBs)

Fluorescent light fixtures were identified throughout the areas assessed. Lamp types that are ballast dependent were noted to be retrofitted with newer T8 lamps. Therefore, ballasts associated with all fluorescent light fixtures are not suspected of containing PCBs.

Ozone Depleting and Global Warming Substances

No Ozone Depleting / Global Warming Substances were identified within the assessed areas at the time of the assessment.

4.0 CONCLUSIONS AND RECOMMENDATIONS

4.1 Designated Substances

4.1.1 Asbestos

Results of our assessment indicated that the following asbestos-containing materials are present within project-specific assessment areas that may be disturbed as part of the planned renovation project:

Friable Asbestos-Containing Materials

- Parging cement on mechanical pipe fittings above lay-in ceilings in corridor 802 (lobby), room 102 (copy room), room 103 (office), and room 138 (storage).

Non-Friable Asbestos-Containing Materials

- 9"x9" beige with brown streak vinyl floor tiles within rooms 137 (work room) and 138 (storage).
- Black mastic associated with floor tiles throughout the original building.
- White exterior caulking at windows of the original building.
- Black exterior caulking at doors of the original building.
- Gold acoustic sink coat on the underside of two (2) sinks within room 106 (staff room),

No other asbestos-containing materials were identified or are suspected present within the project-specific assessment areas. This assessment was limited to sampling of materials that have the potential to be impacted by planned renovation work, as reported by the WRDSB. Assessment of other areas or materials within the building was not conducted. Asbestos-containing materials and other designated substances are present in other areas of the building, which are not identified in this report. If the scope of work expands beyond the limit of our assessment then stop work immediately and assess, as needed.

Non-friable asbestos-containing materials in GOOD condition can be managed in place until activities which could result in disturbance of this material. In the event the non-friable asbestos-containing materials are removed, Type 1 operations apply (provided that the material is wetted down and removed using non-powered hand held tools) as outlined in Ontario Regulation 278/05, *Designated Substance - Asbestos on Construction Projects and in Buildings and Repair Operations* – made under the Ontario Occupational Health and Safety Act. If the material cannot be adequately wetted, Type 2 operations apply.

As per O. Reg. 278/05, removal or disturbance of less than 1 square meter of friable ACM, such as paring cement, is classified as a Type 2 operation provided the removal is performed using non-powered hand tools only. Removal of greater than 1 square meter of friable ACM shall be conducted as a Type 3 operation

The removal or disturbance of ACM must follow the measures and procedures indicated in Ontario Regulation 278/05. This work should be conducted by workers who have received proper training by a “competent person” in the hazards of asbestos exposure, personal hygiene and work practices, and the use and care of respirators and protective clothing. Any worker/supervisor who works in a Type 3 operation must successfully complete the Asbestos Abatement Worker or Supervisor Training Program approved by the Ministry of Training, Colleges and Universities.

It is recommended that work involving the removal or disturbance of ACM be subject to inspection and testing to document conformance with Ontario Regulation 278/05 requirements. The degree of inspection and testing is dependent on site-specific conditions such as the type, duration, size and location of the work.

4.1.2 Lead

All paint samples collected for lead content analysis were found to have a ‘*de minimis*’ level of lead in paint (virtually safe) in accordance with the October 2014 EACC Lead Guideline. Provided these materials are disturbed in a non-aggressive manner and the work is performed using normal dust control procedures, then worker protection from the inhalation of lead is not required. General health and safety precautions must still be implemented, such as prohibiting eating, drinking, smoking and chewing in the work area, implementing dust suppression techniques and providing washing facilities for workers to wash hands and face.

Lead may also be present as a component in solder in pipe fittings and electrical equipment. Removal or disturbance of these materials, if applicable, should be performed using non-powered hand tools and no hot work should be performed on pipes containing solder.

If practicable, all bulk lead waste materials should be separated from other wastes and sent to a recycling facility. If not practicable, lead-containing waste should be handled and disposed of according to R.R.O. 1990 Regulation 347 (Reg. 347), *General – Waste Management*, made under the Environmental Protection Act. Under this regulation (and depending on the quantity of waste generated) the waste may be subject to analysis following the Toxicity Characteristic Leaching Procedure (TCLP) to determine if it is a “leachate toxic waste” based on the leachate quality criteria provided in Schedule 4 of the regulation. Such wastes must meet specific treatment requirements (Schedule 5) or undergo alternative treatment for hazardous debris (Schedule 8) prior to land disposal.

4.1.3 Mercury

Fluorescent light fixtures should be handled with care and kept intact to avoid potential exposure to mercury vapour present within the lamps/bulbs. Under Reg. 347, waste mercury produced in amounts less than 5 kilograms (kg) are exempt from hazardous waste registration, treatment and disposal requirements and can be disposed of in landfill as regular waste. Larger quantities of waste mercury must be treated and disposed of in accordance with the requirements of Reg. 347.

Although no mercury was visibly identified in other equipment, dismantling of equipment (if present) was not conducted to verify the presence/absence of mercury. It is cautioned that thermometers, barometers, and other measuring devices (pressure gauges/sensors, vacuum gauges, manometers, etc.), thermostats, and a variety of other electrical switches (temperature sensitive, tilt switches, float switches, etc.) may contain mercury that may not be visible without dismantling the equipment. Such devices should be assumed to contain mercury until proven otherwise and similar precautions to those outlined above should be taken if any of those items are to be disturbed or taken out of service in the future.

4.1.4 Silica

Suspect silica-containing materials were identified throughout the assessed areas. In their current state, building materials containing silica do not represent a risk to building occupants or construction workers. Risks associated with exposure to silica arise during demolition activities that cause silica dust to be created (particularly grinding, drilling or cutting operations and during major demolition), resulting in a crystalline silica inhalation hazard.

If any materials suspected to contain silica are to be removed or otherwise disturbed as a result of renovation or demolition activities it is recommended that procedures be put in place to control the generation of dust (such as routine water misting) and thus reduce the potential for worker exposure. Workers that have the potential to be exposed to airborne silica should also wear appropriate protective clothing and respiratory protection.

Any work involving the disturbance of silica-containing materials should follow the procedures outlined in the MLITSD "*Silica on Construction Projects*" guideline (April 2011). The appropriate engineering controls, work practices, hygiene practices, personal protective measures and training necessary to conduct the work in a safe manner are provided in this guideline. The general measures and procedures (or Type of operation) necessary depends on the type of work to be conducted.

4.1.5 Other Designated Substances

No other designated substances are expected to be a component of building materials within the surveyed area in a form that would represent an exposure concern. Therefore, no protective measures or procedures specific to acrylonitrile, arsenic, benzene, coke oven emissions, ethylene oxide, isocyanates, and vinyl chloride are considered necessary.

4.2 Other Hazardous Materials

4.2.1 Chemical Hazards

As no UFFI was identified or is suspected to be present within the surveyed area no further action is required. However, although intrusive testing was conducted, there is a remote possibility that UFFI could be hidden within locations such as exterior wall cavities that were not investigated. If suspect foam insulation is identified during demolition activities work should be stopped and the area should be re-assessed to evaluate conditions and determine appropriate control measures and worker protection, if necessary.

4.2.2 Biological Hazards

Mould Contamination

No mould contamination was visually identified in the surveyed area(s) and therefore no further action is required at this time.

4.2.3 Environmental Hazards

Polychlorinated Biphenyls (PCBs)

None identified in the area(s) assessed, no action required.

Ozone Depleting and Global Warming Substances

None identified in the area(s) assessed, no action required.

5.0 LIMITATIONS

The information and recommendations detailed in this report were carried out by trained professional and technical staff in accordance with generally accepted environmental and industrial hygiene work practices and procedures. Recommendations provided in this report have been generated in accordance with accepted industry guidelines and practices. These guidelines and practices are considered acceptable as of the date of this report.

In preparation of this report, Safetech Environmental Limited (Safetech) relied on information supplied by others, including without limitation, information pertaining to the history and operation of the site, and testing services provided by independent laboratories. Except as expressly set out in this report, Safetech has not made any independent verification of information provided by independent entities.

The collection of samples at the location noted was consistent with the scope of work agreed-upon with the person or entity to whom this report is addressed and the information obtained concerning prior site investigations. As conditions between samples may vary, the potential remains for the presence of unknown additional contaminants for which there were no known indicators.

The analytical method used for determination of asbestos content meets the requirements of O.Reg. 278/05. However, small asbestos fibres may be missed by PLM due to resolution limitations of the optical microscope. Interfering binder/matrix and/or low asbestos content may also hinder positive identification by PLM. These conditions are common for vermiculite attic insulation (VAI) and non-friable organically bound (NOB) materials such as vinyl floor tiles, roofing materials, mastics and caulking and can lead to “false negative” results. If PLM analytical results for these types of materials indicate no asbestos detected they have been reported as “Presumed Non-ACM”. Due to limitations of the analytical method we cannot confirm that low quantities of asbestos are not present in these samples using solely PLM analysis. Additional analytical procedures should be considered for such materials to rule out false negative results.

Conclusions are based on site conditions at the time of inspection and can only be extrapolated to an undefined limited area around inspected locations. The extent of the limited area depends on building construction and conditions. Building materials that are not detailed within this survey due to inaccessibility during the time of survey and/or are uncovered during demolition activities should be properly assessed by a qualified person prior to their disturbance. Safetech cannot warrant against undiscovered environmental liabilities. If any information becomes available that differs from the findings in this report, we request that we be notified immediately to reassess the conclusions provided herein.



No other person or entity is entitled to use or rely upon this report without the express written consent of Safetech Environmental Limited and the person or entity to who it is addressed. Any use that a third party makes of this report, or any reliance based on conclusions and recommendations made, are the responsibility of such third parties. Safetech accepts no responsibility for damages suffered by third parties as a result of actions based on this report.

Appendix A

Condition Assessment Criteria for Asbestos-Containing Materials

The condition of asbestos-containing materials identified within the surveyed area(s) was assessed as Good (G), Fair (F) or Poor (P). The assessment criteria used to determine condition is dependent on material characteristics, such as friability. The following Table summarizes the criteria used by Safetech to evaluate the condition of ACM.

Condition Assessment Criteria for Asbestos-Containing Materials

Sprayed Fireproofing, Sprayed Insulation and Sprayed Texture Finishes	
Good	<ul style="list-style-type: none"> • Surface shows no significant signs of damage, deterioration, or delamination (i.e. <1%). • Unencapsulated or unpainted fireproofing or texture finishes, where no delamination or damage is observed. • Encapsulated fireproofing or texture finishes where encapsulation applied after damage or fallout.
Fair	<ul style="list-style-type: none"> • Not utilized as part of condition assessment for these materials.
Poor	<ul style="list-style-type: none"> • Greater than 1% damage, delamination, or deterioration to surface.
In areas where damage exists in isolated locations, both Good and Poor may be applicable.	
Mechanical Insulation (boilers, breeching, ductwork, piping, tanks, equipment, etc.)	
Good	<ul style="list-style-type: none"> • Insulation completely covered in jacketing and exhibits no evidence of damage or deterioration. • Jacketing may have minor damage (i.e. scuffs or stains), but is not penetrated.
Fair	<ul style="list-style-type: none"> • Minor penetrating damage to jacketed insulation (cuts, tears, nicks, deterioration or delamination). • Undamaged insulation that had never been jacketed. • Insulation is exposed but not showing surface disintegration. • Extent of missing insulation ranges from minor to none. • Damage that can be repaired.
Poor	<ul style="list-style-type: none"> • Original insulation jacket is missing, damaged, deteriorated, or delaminated. • Insulation is exposed and significant areas have been dislodged. • Damage that cannot be easily repaired.
Non-Friable and Potentially Friable Materials (includes materials such as plaster finishes, drywall compound, ceiling tiles, asbestos cement products, vinyl asbestos tile and asbestos paper backed vinyl sheet flooring, etc., which have the potential to become friable when handled)	
Good	<ul style="list-style-type: none"> • No significant damage. • Material may be cracked or broken but is stable and not likely to become friable upon casual contact. • No friable debris present
Fair	<ul style="list-style-type: none"> • Not utilized as part of condition assessment for these materials.
Poor	<ul style="list-style-type: none"> • Material is severely damaged. • Debris is present or binder has disintegrated to the point where the material has become friable.
Asbestos-Containing Debris (noted separately from the presumed source material)	
Poor	<ul style="list-style-type: none"> • Debris is always considered to be in Poor condition.

Appendix B

Figure AS01

NOTES:

1. Refer to the report titled "Project-Specific Designated Substance & Hazardous Materials Assessment Crestview Public School 153 Montcalm Drive, Kitchener, Ontario" for complete details.
2. Figure to be referenced with the report.
3. Figure is not to scale.
4. Floor plans provided by the Waterloo Region District School Board (WRDSB).
5. Figure is colour dependent; photocopies may alter interpretations of the figure.
6. Sample locations are approximate.
7. The project-specific assessment area was defined by WRDSB.
8. This assessment was limited to sampling of materials that have the potential to be impacted by planned renovation work, as reported by the WRDSB.
9. Asbestos-containing materials and other designated substances are present in other areas of the building which are not identified in these figures of the report. If the scope of work expands beyond the limit of our assessment area then stop work and assess as needed.

The following asbestos-containing materials are present within the project-specific work areas:

1. Parping cement on mechanical pipe fittings above lay-in ceilings in corridor 802 (lobby), room 102 (copy room), room 103 (office), and room 138 (storage);
2. 9"x9" beige with brown streak vinyl floor tiles within rooms 137 (work room) and 138 (storage);
3. Black mastic associated with floor tiles throughout the original building;
4. White exterior window caulking at windows of the original building; and,
7. Gold acoustic sink coat on the underside of two (2) sinks within room 106 (staff room).

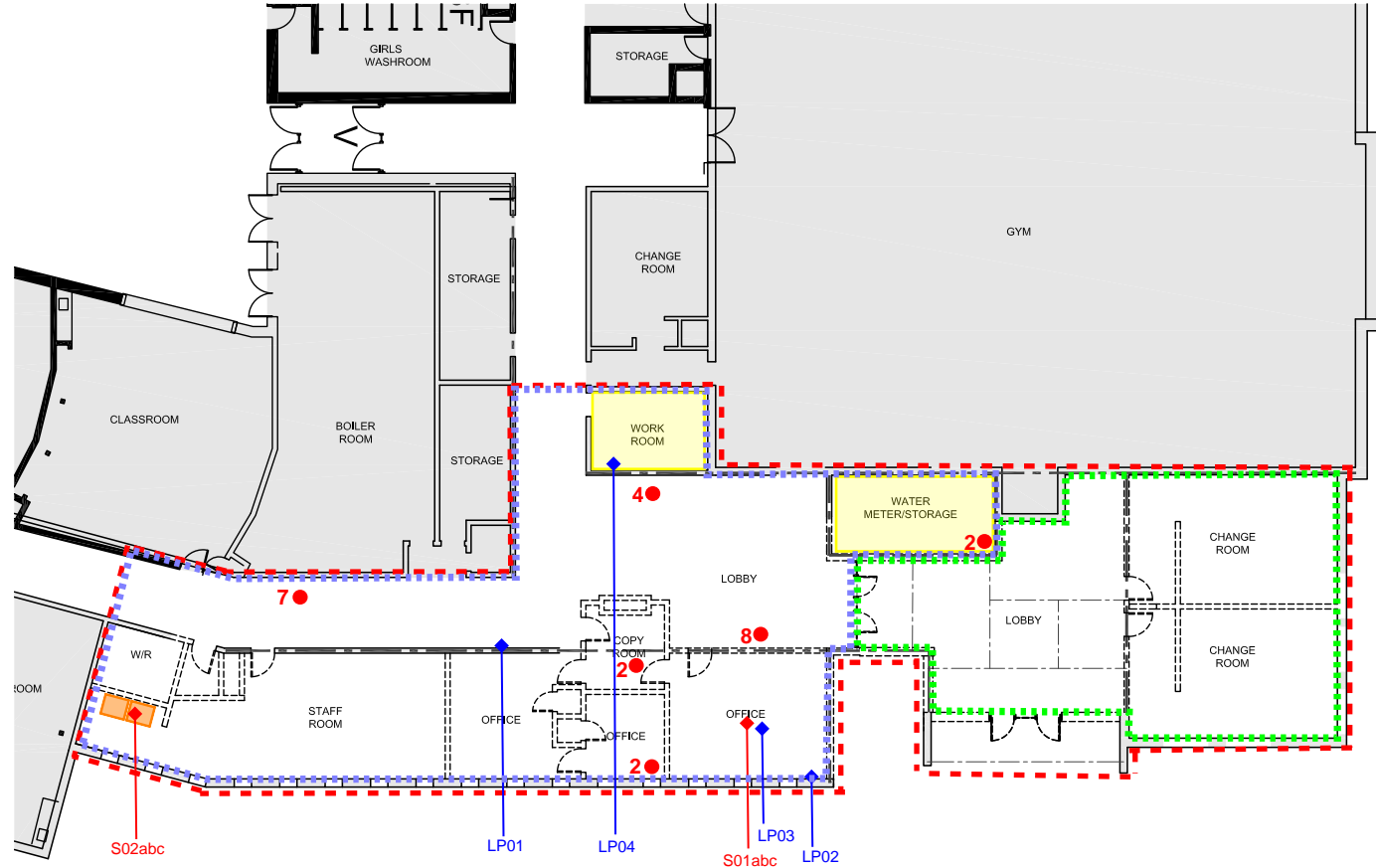

LEGEND:

- ◆ Asbestos Sample Location (approximate)
- ◆ Lead Sample Location (approximate)
- Asbestos-Containing Vinyl Floor Tiles
- Asbestos-Containing Sink Coat
- Asbestos-Containing Parged Cement Pipe Fitting Insulation Location and Quantity (approximate)
- Extent of Assessment Area
- Extent of Original Building
- Extent of 1991 Building Addition

PROJECT:

Project-Specific DSHM Assessment
Crestview Public School Renovation Project

DRAWING NAME:

Extent of Assessment and Designated Substance & Hazardous Materials Sample Locations for the Crestview Public School Renovation Project

Prepared for:



Waterloo Region
District School Board
51 Ardelt Avenue
Kitchener, Ontario
N2C 2R5

Prepared by:



Safetech
Environmental
Limited
100 Hanson Avenue,
Unit 2, Kitchener, ON
N2C 2E2

Safetech Project No.: 2-3250018

Building Address: 153 Montcalm Drive, Kitchener, Ontario

SURVEY DATE: February 28, 2025

DRAWING BY: SD

DRAWING #: AS-01

APPROVED BY: JJG

Appendix C

Laboratory Certificates of Analysis – Asbestos & Lead

Laboratory Analysis Report

To:

Shannon Deline
Safetech Environmental Ltd.
100 Hanson Avenue, Unit 2
Kitchener, Ontario
N2C 2E2

EMC LAB REPORT NUMBER: A116246
Job/Project Name: Crestview P.S
Analysis Method: Polarized Light Microscopy – EPA 600
Date Received: March 4/25 **Date Analyzed:** Mar 11/25
Analyst: Katelyn Stolte
Reviewed By: Malgorzata Sybydlo 

No. of Phases Analyzed: 4
Job No: 2-3250018
Number of Samples: 6
Date Reported: Mar 11/25

Client's Sample ID	Lab Sample No.	Description/Location	Sample Appearance	SAMPLE COMPONENTS (%)		
				Asbestos Fibres	Non-asbestos Fibres	Non-fibrous Material
S01A	A116246-1	Caulking at deck	Off white, caulking	ND	1	99
S01B	A116246-2	Caulking at deck	Off white, caulking	ND	1	99
S01C	A116246-3 ⁵	Caulking at deck	Off white, caulking	ND	1	99
S02A	A116246-4	Gold sink coat	Gold, mastic	Chrysotile	3	97
S02B	A116246-5	Gold sink coat	NA	NA		
S02C	A116246-6	Gold sink coat	NA	NA		

Note:

1. Bulk samples are analyzed using Polarized Light Microscopy (PLM) and dispersion staining techniques. The analytical procedures are in accordance with EPA 600/R-93/116 method.
2. The results are only related to the samples analyzed. **ND** = None Detected (no asbestos fibres were observed), **NA** = Not Analyzed (analysis stopped due to a previous positive result)
3. This report may not be reproduced, except in full without the written approval of EMC Scientific Inc. This report may not be used by the client to claim product endorsement by NVLAP or any other agency of the U.S. Government.
4. The Ontario Regulatory Threshold for asbestos is 0.5%. The limit of quantification (LOQ) is 0.5%.
5. Another phase is present but is too small to analyze.

C.O.C.: -

REPORT No: 25-005634 - Rev. 0

Report To:

EMC Scientific Inc.
 5800 Ambler Dr. #100
 Mississauga, ON L4W 4J4

CADUCEON Environmental Laboratories

2378 Holly Lane
 Ottawa, ON K1V 7P1

Attention: Alister Haddad

DATE RECEIVED: 2025-Mar-05
 DATE REPORTED: 2025-Mar-07
 SAMPLE MATRIX: Paint Chips

CUSTOMER PROJECT: Crestview P.S.
 P.O. NUMBER: 2-3250018

Analyses	Qty	Site Analyzed	Authorized	Date Analyzed	Lab Method	Reference Method
ICP/OES (Solid)	4	OTTAWA	APRUDYVUS	2025-Mar-06	D-ICP-02	EPA 6010

R.L. = Reporting Limit
 NC = Not Calculated

Test methods may be modified from specified reference method unless indicated by an *

Client I.D.	Sample I.D.	Date Collected	Parameter
			Units
			R.L.
			-
LP01 Cream on block	25-005634-1	2025-Feb-28	23
LP02 Light grey on block	25-005634-2	2025-Feb-28	199
LP03 White on deck	25-005634-3	2025-Feb-28	272
LP04 Lime green on block	25-005634-4	2025-Feb-28	95



Michelle Dubien
Data Specialist



Appendix D

Site Photographs – February 28, 2025



P1 – Asbestos-Containing Mechanical Pipe Fittings

Photograph of asbestos-containing parging cement on mechanical pipe fittings observed to be in fair condition within the lobby. The parging cement is undamaged butunjacketed.



P2 – Asbestos-Containing Mechanical Pipe Fittings

Photograph of asbestos-containing parging cement on mechanical pipe fittings observed to be in poor condition within the lobby. The parging cement is unjacketed and damaged.



P3 – Asbestos-Containing 9”x9” Vinyl Floor Tiles

Photograph of asbestos-containing 9”x9” beige with brown streak vinyl floor tiles identified within the work room and storage room. The floor tiles are in good condition.



P4 – Asbestos-Containing Gold Acoustic Sink Coat

Photograph of asbestos-containing gold sink coat identified on the underside of two (2) sinks within the staff room. The sink coating is in good condition.

Appendix E

Background Information on Designated Substances and Other Hazardous Materials



DESIGNATED SUBSTANCES

The Occupational Health and Safety Act of Ontario (OHSA) allows for certain toxic substances to be especially designated. The OHSA defines a designated substance as “a biological, chemical, or physical agent or combination thereof prescribed as a designated substance to which the exposure of a worker is prohibited, regulated, restricted, limited, or controlled.” Ontario Regulation 490/09 - Designated Substances (O. Reg. 490/09), made under the Occupational Health and Safety Act outlines required steps to control exposure of workers to designated substances. Under O. Reg. 490/09 there are eleven (11) designated substances; acrylonitrile, arsenic, asbestos, benzene, coke oven emissions, ethylene oxide, isocyanates, lead, mercury, silica and vinyl chloride. This regulation applies to every employer and worker at a workplace where the designated substances are present, produced, processed, used, handled or stored and at which a worker is likely to be exposed to the designated substance.

Section 14 of O. Reg. 490/09 exempts an employer and the workers of an employer who engage in construction from the requirements of the regulation. However, designated substances are still required to be identified prior to the beginning of a demolition or renovation project to ensure that construction workers (and potentially building occupants) are adequately protected from the hazards posed by the presence of these materials if the planned work may cause them to be disturbed. Accordingly, under Section 30 of the OHSA building owners are required to perform an assessment to determine whether any designated substances are present at the project site before the beginning of the project. The owner is also required to prepare a list of designated substances that are present at the site and provide this list to prospective constructors before entering into a binding contract with the constructor. This way, contractors and construction workers are made aware of designated substances present within the work area so that appropriate measures can be taken during the work to limit exposure to these substances.

Designated Substances and Hazardous Materials Assessments are conducted to conform to the requirements of Section 30 of the OHSA. The assessments are performed to identify designated substances (and other hazardous materials) within the work area that may present a hazard to workers if disturbed. These substances are commonly a component of building materials or equipment found in buildings. Additional information regarding the eleven designated substances including their properties, uses and health effects are provided below.

Acrylonitrile

Acrylonitrile (ACN) is a clear, colourless or pale yellow liquid with a pungent onion- or garlic-like, irritating odour. It is highly flammable and as such is a severe fire and explosion hazard.

Acrylonitrile is used mainly as a monomer or comonomer in the production of acrylic fibres, plastics, resins and nitrile rubbers. Historically, a mixture of acrylonitrile and carbon tetrachloride was used as a pesticide; however, all pesticide uses have stopped. Based on its use as a chemical intermediate, exposure to acrylonitrile is primarily occupational, via inhalation during its manufacture and use. Therefore, this designated substance is not expected to be encountered in buildings where it is not either produced or used in a manufacturing process.

Acute (short-term) exposure of workers to acrylonitrile has been observed to cause mucous membrane irritation, headaches, dizziness, and nausea. More significant exposures may lead to symptoms such as limb weakness, labored and irregular breathing, impaired judgment, cyanosis, collapse, and convulsions. Exposure of the skin to high concentrations of acrylonitrile in the air may irritate the skin and cause it to turn red while direct skin contact with acrylonitrile may cause the skin to blister and peel. The International Agency for Research on Cancer (IARC) concluded that there is inadequate evidence in humans for the carcinogenicity of acrylonitrile, but has classified it as possibly carcinogenic to humans (Group 2B).

Arsenic

Arsenic is a naturally occurring mineral, widely distributed in the earth's crust. Elemental arsenic (sometimes referred to as metallic arsenic) is a silver-gray or white brittle metal. However, arsenic is usually found in the environment combined with other elements such as oxygen, chlorine, and sulfur to form inorganic arsenic compounds. Arsenic has no odour and is almost tasteless.

Arsenic and its compounds have a variety of commercial uses. Inorganic arsenic compounds are mainly used as a wood preservative. Copper chromated arsenic (CCA) is used to make "pressure-treated" lumber. CCA-treated wood is no longer used for residential applications but may still be used in industrial applications. Arsenic is also used in metallurgy for hardening copper, lead and certain metal alloys, in pigment production, in the manufacture of certain types of glass, and in semiconductors and light-emitting diodes. Inorganic arsenic compounds are no longer used as pesticides in agriculture; however, organic arsenic compounds, namely cacodylic acid, disodium methylarsenate (DSMA), and monosodium methylarsenate (MSMA), are used, as yet, as pesticides – principally on cotton.

Today, workplace exposure to arsenic may still occur in some occupations that use arsenic, such as copper or lead smelting, wood treating, or pesticide application. Exposure to arsenic within buildings other than where it is used as part of the manufacturing process is unlikely and therefore arsenic is not expected to be encountered as part of a routine hazardous building materials assessment.

Human exposure to arsenic can cause both short and long term health effects. Short-term or acute effects can occur within hours or days of exposure. If you breathe high levels of inorganic arsenic, then you are likely to experience a sore throat and irritated lungs. Longer exposure at lower concentrations can lead to skin effects (such as darkened patches of skin and areas of thickened skin), and also to circulatory and peripheral nervous disorders. An important concern is the ability of inhaled inorganic arsenic to increase the risk of cancer. Long term exposure to arsenic has been linked to cancer of the bladder, lungs, skin, kidneys, nasal passages, liver and prostate. The IARC classifies arsenic and arsenic compounds as "carcinogenic to humans" (Group 1).

Asbestos

Asbestos is the name given to a number of naturally occurring fibrous minerals found in the environment. Ontario Regulation 490/09 (Designated Substances) defines asbestos as any one of the following fibrous silicates: actinolite; amosite; anthophyllite; chrysotile; crocidolite; and tremolite. Asbestos fibres have several desirable characteristics such as high textile strength, the ability to be spun and woven, and resistance to heat and most chemicals. These characteristics have resulted in the historical use of asbestos in a wide variety of building materials and other manufactured goods. Examples of products where asbestos has been used include roofing shingles, ceiling and floor tiles, insulation, sprayed fireproofing, gaskets, and friction products such as automotive brakes and clutches.

The peak years for asbestos use were in the 1960s and early 1970s. Therefore, asbestos is commonly found in building materials of this era. The use of asbestos in building materials and other products has decreased significantly since this time. Friable asbestos-containing materials (material that when dry can be crumbled, pulverized or powdered by hand pressure), such as sprayed fireproofing and sprayed insulation, ceased use circa 1973. Mechanical thermal system insulation ceased use circa 1981 while sprayed acoustic texture coat finishes ceased use circa 1982. Non-friable asbestos-containing materials were generally manufactured for a longer period of time (with the exception of plaster finishes which ceased use circa 1960's). Asbestos-containing drywall joint compound ceased use circa 1980. Vinyl floor tiles, vinyl sheet flooring and acoustic ceiling tile ceased use 1982. Other non-friable materials continued to be produced into the 1990's, including roofing materials (ceased use circa 1991) and floor adhesives (ceased use circa 1992). Today, asbestos is a controlled substance, and is banned for use in most products sold in Canada under the Hazardous Products Act (with the exception of certain roof shingles, clutch facings and brake linings).

Potentially harmful exposure to asbestos occurs through inhalation of air containing asbestos fibres. The greatest risk for workplace exposure to airborne asbestos is in occupations that produce and use asbestos, such as in mining and milling operations or in the manufacture of products containing asbestos. Exposure to airborne asbestos fibres may also occur to construction workers, trades people, maintenance workers and other building occupants in buildings constructed with asbestos-containing materials; especially during building renovations or repairs or if the materials are in poor condition or are otherwise disturbed.

Health risks associated with asbestos exposure are dependent on several factors such as the type and airborne concentration of asbestos, and period of exposure. In general, the greater the exposure to asbestos, the greater the chance of developing harmful health effects. Typically, chronic, daily exposure to elevated airborne concentrations of asbestos over a period of years is required for health effects to eventually manifest themselves. Health effects associated with exposure to asbestos can result in asbestosis (a scarring of the lungs which makes breathing difficult), mesothelioma (a rare cancer of the lining of the chest or abdominal cavity) and lung cancer. The link between exposure to asbestos and other types of cancers and health effects is less clear.

Benzene

Benzene is a clear, colourless liquid with a characteristic, sweet or aromatic hydrocarbon odour. It is a liquid at room temperature but evaporates into the air very quickly, making it a highly flammable vapour as well as an extremely flammable liquid.

Benzene is formed from both natural processes and human activities. Natural sources of benzene include volcanoes and forest fires. Benzene is also a natural part of crude oil, gasoline, and cigarette smoke. It is produced from petroleum and coal sources and is used mainly in the manufacture of other chemicals which are used to make plastics, resins, and nylon and synthetic fibres. Benzene is also used to make some types of rubbers, lubricants, dyes, detergents, drugs, and pesticides.

Exposure to pure benzene within buildings other than where it is produced or used as part of a manufacturing process is unlikely. Therefore benzene is not expected to be encountered as part of a routine hazardous building materials assessment.

Exposure to benzene primarily occurs through inhalation of airborne vapours. Short-term (acute) health effects associated with overexposure to benzene vapours can result in symptoms such as headache, nausea, dizziness, drowsiness and confusion, with unconsciousness or even death at very high levels. Long-term (chronic) exposure to Benzene may cause blood and bone marrow effects which can lead to anemia and leukemia (cancer of the blood-forming organs) as well as cause damage to the immune system, increasing the chance for infection. The IARC classifies benzene as "carcinogenic to humans" (Group 1).

Coke Oven Emissions

Coke Oven Emissions refers to the benzene soluble fraction of total particulate matter emitted during the destructive distillation or carbonization of coal for the production of coke (pure carbon). These emissions are a mixture of coal tar, coal tar pitch, volatiles (including benzene, toluene and xylene), creosote, polycyclic aromatic hydrocarbons (PAHs – including benzo(a)pyrene, benzanthracene, chrysene and phenanthrene), and metals (including cadmium, arsenic, beryllium and chromium). Condensed coke oven emissions are a brownish, thick liquid or semisolid with a naphthalene-like odour, while uncondensed coke oven emissions are vapours that escape when the ovens are changed and emptied and are a component of fugitive emissions.

The coke produced is used as a component in the manufacturing of iron and steel. Coke is also used to synthesize calcium carbide and to manufacture graphite and electrodes. Additional chemicals recovered from the coke oven emissions (such as benzene, toluene, naphthalene, sulfur, and ammonium sulfate) are used as raw materials for plastics, solvents, dyes, drugs, waterproofing, paints, pipe coating, roads, roofing, insulation, and as pesticides and sealants.

Coke oven emissions would only be present within facilities producing or using coke as part of the manufacturing process and thus occupational exposure is limited to those workers in the aluminum, steel, graphite, electrical, and construction industries. Therefore, coke oven emissions are not a contaminant of concern during a routine hazardous building materials assessment.

Chronic (long-term) exposure to coke oven emissions can result in chronic bronchitis (particularly those who smoke) and additional health effects such as conjunctivitis, severe dermatitis, and lesions of the respiratory system and digestive system. However, the greatest concern regarding chronic exposure to coke oven emissions is the increased risk of cancer. The IARC classifies coke production as "carcinogenic to humans" (Group 1). The site at which excess cancer rates have been identified most commonly among workers in coke production is the lung. Excess risk for kidney cancer has also been associated with work in coke plants. Additional studies have also reported excess risks for other types of cancers such as cancer of the large intestine and pancreas.

Ethylene Oxide

Ethylene oxide is colourless gas with a somewhat sweet odour. It is extremely flammable and also dangerously reactive. Ethylene oxide exists as a compressed gas that has been produced since the early 1900s. It is used primarily as a chemical intermediate in the production of ethylene glycol, glycol ethers, non-ionic surfactants and other industrial chemicals. Much smaller amounts are used as a non-explosive mixture with nitrogen or carbon dioxide for sterilizing medical instruments and supplies in hospitals and industrially for the fumigation of spices.

Most people are not likely to be exposed to ethylene oxide because it is not commonly found in the environment. Exposure to ethylene oxide is generally limited to those facilities where it is made or used. Therefore, ethylene oxide is not a contaminant of concern during a routine hazardous building materials assessment, although the presence of it should be determined in buildings such as hospitals if construction activities are to occur in or adjacent to areas where it is used or stored.

Exposure to ethylene oxide can result in irritation to the skin or eyes; however, the greatest risk for health effects is through inhalation. This can result in irritation to the nose, throat and respiratory tract, with damage to the central nervous system at higher concentrations. Exposure to high concentrations may cause headache, nausea, dizziness, drowsiness, and incoordination. Exposure to ethylene oxide is also a cancer hazard and possible reproductive hazard. In epidemiological studies of exposure to ethylene oxide, the most frequently reported association has been with lymphatic and haematopoietic cancer. The IARC has concluded that there is limited evidence for the carcinogenicity of ethylene oxide in humans and sufficient evidence for carcinogenicity in experimental animals, classifying ethylene oxide as “carcinogenic to humans” (Group 1).

Isocyanates

Isocyanates are a family of highly reactive, low molecular weight, manufactured chemicals containing one or more isocyanate groups (-NCO). An isocyanate that has two isocyanate groups is known as a diisocyanate, which are the most common type of isocyanates used for manufacturing other products. The most commonly used diisocyanates include methylene diphenyl diisocyanate (MDI), toluene diisocyanate (TDI), and hexamethylene diisocyanate (HDI).

When isocyanates are combined with other compounds that contain free hydroxyl functional groups (i.e. –OH) they react and begin to form polyurethane polymers. These polyurethanes find significant application in the manufacture of rigid and flexible foams. Flexible foam is primarily used for cushioning, while rigid foam is used mainly for insulation. Polyurethanes are also used in the production of adhesives, elastomers, and coatings and are increasingly used in the automobile industry, autobody repair, and building insulation materials.

This diversity of applications means that exposures to isocyanates can occur in a broad range of production facilities from small workshops to automated production lines. Jobs that may involve exposure to isocyanates include painting, foam-blowing, and the manufacture of many polyurethane products. Exposure to isocyanates within buildings where it is not produced or used as part of manufacturing is unlikely, as products such as rigid foam insulation that may be used in buildings has already undergone the curing process. Completely cured products are fully reacted and therefore are considered to be inert and non-toxic. However, some products such as spray foams, coatings, sealants and adhesives may be sold and used in an uncured form. An example would be an adhesive, which is sold to be initially applied in an uncured form and as it cures (hardens), bonds two pieces of wood together. Such products can provide potential exposure to building occupants and construction workers during the application and use of these products. However, for the purposes of a routine hazardous building materials assessment, products that may have contained isocyanate as part of the manufacturing process (e.g. rigid foam) or during the application/installation process (e.g. spray foam, adhesives and sealants) are assumed to be fully cured and would no longer contain free isocyanate.

Direct skin contact with isocyanates can cause marked skin irritation, resulting in reddening, swelling and blistering. However the greatest route of exposure to isocyanates is through inhalation of fine vapours or droplets. Airborne exposure to isocyanates can result in irritation to the mucous membranes of the eyes and respiratory tracts. This results in symptoms such as excessive tear secretion, dry throat, dry cough, chest pains and difficulty in breathing. Isocyanates are also a major cause of work-related asthma worldwide. Increased exposure to isocyanates can lead to sensitization. Once sensitized, individuals are subject to severe asthma attacks (which in some cases has been reported to result in death) if they are re-exposed.

Lead

Lead is a naturally occurring metal found in small amounts in the earth's crust. It is usually found in ore with zinc, silver and (most abundantly) copper, and is extracted together with these metals. Metallic lead is bluish-white in colour but soon tarnishes to a dull grey when exposed to air. When melted into liquid form it has a shiny chrome-silver appearance.

Lead is soft, dense, highly malleable and resistant to corrosion, with poor electrical conductivity as compared to most other metals. Such properties have resulted in lead being used in many applications, including products and materials commonly found in buildings. It is present as a component of lead-acid batteries, ammunition, PVC plastics, and older brass and chrome-plated brass faucets. As a building component, lead has been used in water distribution piping, as an alloy in solder, in electrical conduits, roofs and roofing details, and as an additive to paints, ceramic glazes and mortars as pigments

or for anti-corrosion properties. Lead has also used as sheeting inside buildings for shielding X-rays and for sound attenuation.

Exposure to lead can occur for workers in workplaces that produce the above materials but also to construction workers, building maintenance personnel and the general population due to the widespread historical use of lead in building materials and consumer products. Most exposure to lead occurs through ingestion or inhalation, with the health effects being the same. Overexposure to lead can result in damage to nervous connections and can cause blood and brain disorders, severe damage to the kidneys and ultimately death. Infants and young children are especially vulnerable to the health effects of lead, as overexposure has been proven to result in the permanent reduction in cognitive capacity. In pregnant women, high levels of exposure to lead may cause miscarriage. The IARC has concluded that lead and inorganic lead compounds are “possibly carcinogenic to humans” (Group 2B).

The known serious health effects associated with lead exposure has brought about widespread reduction in its use. The use of lead in building materials and consumer products has decreased substantially since the 1970s to where lead is no longer being used in building materials and consumer products or is present at significantly lower concentrations. For example, unleaded gasoline was introduced in Canada in 1975, after which leaded gasoline was phased out and banned in 1990. Lead-based solder has been banned since the 1980s and most solder used today is either lead-free or has very low lead concentrations. Up until the 1960s, lead was added to paints in significant quantities. Since that time, the concentration of lead in paint has decreased. The federal government began reducing the amount of lead allowed in interior paint in 1976 (to 0.5% by weight). By 1991, paint manufacturers in Canada and the U.S. voluntarily stopped adding lead to paint, reducing lead concentrations to background levels. In 2005 the *Surface Coating Materials Regulations* came into effect to limit the concentration of lead in paint (to 0.06% by weight) for both interior and exterior paints sold to consumers. This was since amended in 2011 to further reduce the allowable lead limit (to 0.009% by weight) and extended to include all consumer paints and coatings.

Mercury

Mercury is a naturally occurring element found in the earth's crust, with natural deposits generally found as a vermilion red ore called cinnabar. Mercury can exist as metallic mercury, organic mercury or inorganic mercury. Metallic or elemental mercury has unique properties as compared to other metals. It is the only pure metal that is a liquid at room temperature, having a silvery-white, shiny appearance. Mercury is the densest liquid known, which produces a colourless, odourless vapour at room temperature.

The unique properties of mercury have resulted in it being used in a wide variety of applications. Properties such as its coefficient of expansion and ability to conduct electricity has resulted in mercury being used in thermometers, barometers and other

measuring devices (blood pressure gauges, vacuum gauges, manometers, etc.), thermostats and a variety of other electrical switches (temperature sensitive, tilt switches, float switches, etc.). Mercury is also used in antifouling paints, dry cell or button batteries, and numerous lighting products, including fluorescent lamps and a variety of High Intensity Discharge (HID) lamps such as mercury vapour, metal halide and high pressure sodium lamps. HID lamps are used for street lights, floodlights and industrial lighting applications. Because of the wide variety of uses mercury can be found as a component of machinery, equipment and lighting within buildings; although many of its uses have been phased out over the years.

The health effects of mercury exposure depend on its chemical form (elemental, inorganic or organic), the route of exposure (inhalation, ingestion or skin contact), and the level of exposure. Vapours from liquid elemental mercury and methyl mercury are more easily absorbed than inorganic mercury salts and can, therefore, cause more harm. Exposure to mercury occurs mainly from breathing contaminated air or ingesting contaminated water and food. Mercury is a neurotoxin, which means it can adversely affect the central nervous system. Upon exposure, mercury tends to accumulate quickly in the brain where it tightly binds with the tissue and is released at a very slow rate. The nervous system effects of mercury toxicity are sometimes referred to as "Mad Hatter's Disease" since mercurous nitrate was used in making felt hats. High levels of exposure to mercury can also lead to harmful effects on the digestive and respiratory systems, and the kidneys. Many mercury compounds may also be teratogenic or capable of causing birth defects.

Mercury compounds can also be toxic at low levels in the environment. The characteristics of mercury that make it an environmental problem are its toxicity and persistence in the environment, and its ability to accumulate and bioconcentrate as methyl mercury in fish and fish-eating predators such as large fish or loons. Therefore, proper disposal of mercury-containing materials is essential. The improper disposal of mercury-containing products such as fluorescent light bulb tubes, high intensity discharge lamps, mercury vapour lamps, mercury thermometers and thermostats can lead to the release of mercury from municipal landfills. Used fluorescent and HID lamps may be classified as hazardous waste due to their mercury content and should be recycled if possible rather than being disposed of in landfill.

Silica

Silica (silicon dioxide) is the name of a group of minerals that contain silicon and oxygen in a chemical combination and have the general formula SiO_2 . It is one of the most common minerals in the earth's crust. Silica can be present as crystalline silica (free silica) or amorphous silica (combined silica), and exists in many forms. The three most common crystalline forms of silica encountered in the workplace environment are quartz, tridymite, and cristobalite. Quartz is by far the most common crystalline silica found in nature, being abundant in most rock types, notably granites, sandstones, quartzites and in sands and soils. Cristobalite and tridymite are found in volcanic rocks. Amorphous silica is found in

nature as biogenic silica and as silica glass of volcanic origin. One form of biogenic silica, diatomaceous earth, originates from the skeletons of diatoms deposited on sea floors. From a health perspective it is the crystalline silica forms that raise the biggest concerns.

Silica is present in numerous building materials and products, including concrete, brick, stone, terrazzo, refractory brick, etc. Low concentrations of silica are also possible in plaster, drywall, acoustical ceiling tiles, drywall joint compound, mortars and adhesives. Because of the wide usage of quartz-containing materials, workers may be exposed to crystalline silica in a large variety of industries and occupations. Occupational exposure to silica dust occurs in cement and brick manufacturing, asphalt pavement manufacturing, china and ceramic manufacturing, and the tool and die, steel and foundry industries. Exposure to silica also occurs during many different construction and maintenance activities. The most severe exposures to crystalline silica result from abrasive blasting activities using silica sand. Other activities that may produce crystalline silica dust include jack hammering, rock/well drilling, concrete mixing, concrete drilling, tuck pointing, and brick and concrete block cutting and sawing. Additionally, crystalline silica exposures occur in the maintenance, repair and replacement of refractory brick furnace linings.

Adverse health effects associated with silica exposure result from inhalation of the respirable fraction of crystalline silica, which can arise from many of the activities outlined above. The main health effects associated with silica exposure are lung cancer and silicosis. The IARC has concluded that crystalline silica inhaled in the form of quartz or cristobalite from occupational sources is “carcinogenic to Humans” (Group 1). Silicosis is caused by scarring of the lung tissue from breathing in silica dust. This scarring is permanent and causes a reduction in the lungs’ ability to take in oxygen, making it difficult to breathe and in severe cases can be disabling, or even fatal. Since silicosis affects lung function, it also makes one more susceptible to lung infections like tuberculosis.

Vinyl Chloride

Vinyl chloride is a manufactured substance that does not occur naturally. It is used as a chemical intermediate and not an end product. Vinyl chloride exists in liquid form if kept under high pressure or at low temperatures. At room temperature, it is a colourless gas. It burns easily and is not stable at high temperatures.



Most of the vinyl chloride produced is used to make a polymer called polyvinyl chloride (PVC). PVC is used to make a variety of plastic products including pipes, wire and cable coatings, vinyl flooring, vinyl wallpaper and window frames. It is also used to make furniture, upholstery and packaging materials. One of the concerns regarding PVC is that upon burning it will emit toxic fumes. Contaminants emitted when PVC is burned include hydrochloric acid, carbon monoxide, and carbon dioxide, along with lesser amounts of dioxin and furan.

Vinyl chloride is reported to be slightly irritating to the eyes and respiratory tract in humans. Central nervous system effects (including dizziness, drowsiness, fatigue, headache, visual and/or hearing disturbances, memory loss, and sleep disturbances) as well as peripheral nervous system symptoms (peripheral neuropathy, tingling, numbness, weakness, and pain in fingers) have been reported in workers exposed to vinyl chloride. Short-term (acute) exposure to extremely high levels of vinyl chloride has also reportedly caused loss of consciousness, lung and kidney irritation, and inhibition of blood clotting in humans. The most significant health effect associated with exposure to vinyl chloride is that it is a known human carcinogen that causes a rare cancer of the liver. It has been classified by the IARC as "carcinogenic to humans" (Group 1). Brain cancer, lung cancer, and some cancers of the blood also may be connected with breathing vinyl chloride over long periods.

OTHER HAZARDOUS MATERIALS

CHEMICAL HAZARDS

Urea Formaldehyde Foam Insulation

Urea-formaldehyde foam insulation (UFFI) was developed in as an improved means of insulating difficult-to-reach cavities. It was typically made at the construction site from a mixture of urea-formaldehyde resin, a foaming agent and compressed air. When the mixture is injected into the wall, urea and formaldehyde unite and "cure" into an insulating foam plastic. Its appearance is like ordinary shaving cream. Dry, it can be a white or tan colour, and fluffy like styrofoam. Over time UFFI shrinks significantly and may begin to degrade due to its crumbly texture.

UFFI was installed primarily in wall cavities during the 1970's as an energy conservation measure. The insulation was used most extensively from 1975 to 1978, during the period of the Canadian Home Insulation Program (CHIP), when financial incentives were offered by the government to upgrade home insulation levels. In addition to detached homes it can be found in common areas and walls of semi-detached homes, apartment buildings and condominiums. UFFI was also used to a lesser degree in some commercial and industrial buildings.

UFFI installation has been banned in Canada under the Hazardous Products Act (HPA) since December, 1980 due to concerns regarding the health effects of exposure to formaldehyde. Formaldehyde is a colourless, pungent-smelling gas. Health effects include eye, nose, and throat irritation; wheezing and coughing; fatigue; skin rash; nausea; headache; dizziness; and severe allergic reactions.

Sometimes, a slight excess of formaldehyde was often added to ensure complete "curing" with the urea to produce the urea-formaldehyde foam. The excess formaldehyde was given off after installation during the initial curing process, which typically took a few days to a week to complete. UFFI was sometimes improperly installed or used in locations where it should not have been, resulting in continued off-gassing of formaldehyde past the initial curing stage. Since UFFI was last installed in 1980, it should have little effect on indoor formaldehyde levels today. However, if UFFI comes in contact with water or moisture, it could begin to break down. Due to the age of the insulation UFFI may also begin to degrade and crumble into a fine powder. Under these conditions UFFI may release more formaldehyde and consideration should be given to removing the material using properly trained remediation personnel.

BIOLOGICAL HAZARDS

Mould

Mould is part of the fungi kingdom, which also includes mushrooms and yeasts. They are a naturally occurring and essential part of our environment since they break down dead organic material in the outdoor environment (such as leaves, wood and other plant debris), which they use as a food source.

Mould reproduces by means of tiny spores that are so small they can't be seen by the naked eye. Because of their small size mould spores easily become airborne and can travel long distances, entering indoor environments through ventilation systems, open windows or doors, or tracked in on footwear. Therefore, mould spores are a commonly detected in indoor air and as a component of settled dust.

Under normal conditions, the presence of indoor mould is not an issue. However, if conditions exist that allow it to grow and multiply indoors it can become a potential hazard. Several factors will affect what moulds will grow within a building and how fast they will grow. This includes parameters such as temperature, airflow, and the pH (i.e. acidity/alkalinity) of the food substrate. However, the most important parameter affecting mould growth is water availability, as all moulds need some amount of moisture for them to be able to grow. Buildings that have had a history of water damage are at greater risk of indoor mould growth.

Indoor mould growth may present a risk to the building structure itself through decomposition of building materials. Health risks to building occupants may also occur as

a result of indoor mould growth. Construction or renovation work which disturbs mould-contaminated materials increases this risk of exposure to building occupants and the construction workers themselves. Health effects associated with exposure to mould most commonly results in allergic type reactions such as runny nose, cough, congestion, eye irritation and aggravation of asthma, headache and fatigue. Exposure to very high concentrations of airborne mould spores (such as those that may be observed during disturbance of mould-contaminated building materials) can result in more serious health effects such as Organic Dust Toxic Syndrome (ODTS) or Hypersensitivity Pneumonitis (HP), where flu-like symptoms (fever, chills, cough, fatigue, shortness of breath, body aches, etc.) are exhibited. The chronic form of HP may occur from long-term exposure to lower levels of mould and results in a continued worsening in shortness of breath or cough. A variety of species of mould have also been documented to cause serious invasive infections, which are generally limited to individuals whose immune systems are already somehow compromised.

ENVIRONMENTAL HAZARDS

Polychlorinated Biphenyls

Polychlorinated biphenyls (PCBs) are a class of man-made organic chemicals known as chlorinated hydrocarbons. They vary in consistency from thin, light-coloured liquids to yellow or black waxy solids. They were manufactured in the United States from 1929 until their manufacture was banned in 1979. Although PCBs were not manufactured in Canada, they were imported from the U.S. over the years. Canada banned the import, manufacture and sale of PCBs in 1977.

PCBs are non-flammable, chemically stable over a wide range of temperature and physical conditions, not soluble in water, unaffected by acids, base or corrosive chemicals, and have a high dielectric or electrical insulating capacity. Due to these unique properties PCBs were used in hundreds of industrial and commercial applications, most commonly in electrical transformers and capacitors, including those capacitors found in light ballasts. They were also used as coolants, fire retardants and as insulation and in a number of other commercial applications including carbonless copy paper, dust suppressors for roads, hydraulic fluids, caulking compounds, plasticizers and lubricating oils and heat-transfer applications.

Although PCBs were found to be extremely useful in many industrial and commercial applications some of their chemical properties also made them an environmental and health hazard. PCBs are nearly indestructible and therefore persist if released into the natural environment. Their high fat and low water solubility result in a build-up (bioaccumulation) of PCBs in the fatty tissue of animals and humans if ingested/inhaled. Because PCBs persist in the fatty tissue of animals their concentration will tend to increase the higher up the food chain.

Most of what is known about the human health effects of PCBs is based on exposures due to accidental releases or job-related activities. These exposures are much higher than the levels normally found in the environment. The adverse health effects include a severe form of acne (chloracne), swelling of the upper eyelids, discolouring of the nails and skin, numbness in the arms and/or legs, weakness, muscle spasms, chronic bronchitis, and problems related to the nervous system. The International Agency for Research on Cancer (IARC) classifies PCBs as “probably carcinogenic to humans” (Group 2A) based on limited evidence that long-term, high-level occupational exposure can lead to increased incidence of liver and kidney cancers. The long-term impact of low-level exposures to PCBs that is common in the general population is unclear. The current state of knowledge suggests that low-level exposures to PCBs are unlikely to cause adverse health effects. However, people eating large amounts of certain sports fish, wild game and marine mammals are at increased risk for higher exposures and possible adverse health effects.

Ozone Depleting and Global Warming Substances

There are several different types of chemicals that are being or have been used as refrigerants in commercial, home and vehicle air conditioners and refrigerators or as fire extinguishing agents in portable and fixed fire extinguishing equipment. This includes groups of chemical compounds known as chlorofluorocarbons (CFCs), hydrochlorofluorocarbons (HCFCs) and halons. Some of these chemicals have also been used as foam blowing agents, as cleaning solvents for electrical components, as aerosol spray propellants, and in hospital sterilization procedures. Fixed halon fire extinguishing systems have historically been used in areas such as data centers, IT rooms, museums, libraries, surgical suites, and other locations where use of water-based suppressants could irreparably damage electronics or vital archival collections. There is a large number of halon fire extinguishing systems still in service in Canada.

The concern regarding past and present use of many of the chemicals used as refrigerants or fire extinguishing agents is that they are ozone-depleting substances (ODS). When released into the environment these chemicals break down in the stratosphere and release chlorine or bromine, which destroy the stratospheric ozone layer. The ozone layer screens the earth from some of the sun's harmful ultraviolet rays (UVB). As the ozone layer is depleted, higher UVB levels reach the earth, resulting in increased exposure to UVB. Increased exposure to UVB can cause skin cancer and plays a major role in malignant melanoma development. It can also increase the likelihood of cataracts and may also suppress proper functioning of the body's immune system and the skin's natural defenses.

CFCs, HCFCs and halons are also known to be greenhouse gases and contribute to global warming due to the build-up of these heat-trapping gases in the atmosphere. Hydrofluorocarbons (HFCs) are a common replacement chemical for CFC and HCFC



refrigerants; and although they do not have any ozone depleting potential they are a potent greenhouse gas.

Due to the ozone-depleting potential and/or global warming potential of CFCs, HCFCs, HFCs and halons it is important to control their use and emission into the environment. The manufacture and use of CFCs has stopped while transitional refrigerants (HCFCs) are scheduled to be phased out of production. No phase-out dates are currently planned for any HFCs. In Ontario, Regulation 463/10, "Ozone Depleting Substances and Other Halocarbons" (made under the Environmental Protection Act) enhances the control and management of substances that deplete the ozone layer and contribute to global warming. This regulation has requirements to prevent or minimize ozone-depleting substances and other halocarbons emissions, which serves a dual environmental benefit of lowering emissions that destroy the ozone layer and contribute to climate change.

PART 1 – GENERAL

1.1 General Requirements

- .1 Conform to Division 01 – General Requirements.

1.2 Related Sections

- .1 Section 07 92 10 – Joint Sealing.

1.3 Reference Standards

- .1 Do terrazzo work in accordance with CSC (SWAC) Architectural Specification Study on Terrazzo (Portland Cement) 1976, produced in cooperation with Terrazzo, Tile and Marble Association of Canada (TTMAC), except where specified otherwise.

1.4 Samples

- .1 Submit duplicate 300 x 300 x 20mm (12" x 12" x .75") thick area samples of each colour terrazzo, in accordance with Section 01340.

1.5 Environmental Requirements

- .1 Maintain air temperature and structural base temperature at terrazzo installation area above 10°C (50°F) for 24 hours before. During and 24 hours after installation.

1.6 Maintenance Data

- .1 Provide maintenance data as set out in TTMAC publication for terrazzo work for incorporation into maintenance manual specified in Section 01340.

1.7 Warranty

- .1 Provide a written warranty signed and issued in the name of the Client and Project stating that the Contractor warrants the terrazzo surfaces will not crack in accordance with GC 12.3 as amended by Supplementary General Conditions, but for a period of three (3) years from the date of Substantial Performance of the Work.

PART 2 – PRODUCTS

2.1 Materials

- .1 Cement: To CAN3-A5-M77 type 10 grey for underbed and white for topping. Examine existing terrazzo to be matched.
- .2 Sand: Fine and coarse aggregates to CAN3-A23.1-M77.
- .3 Water: Potable
- .4 Marble Chips: To CSA A194.1-1-1967 for uniformity, soundness and abrasion resistance Grade chips in accordance with TTMAC standard. Match existing.
- .5 Pigments: Non-fading mineral pigments in selected colours.
- .6 Divider strips: 4.75mm (0.19") thick zinc with depth of 32mm (1.25")
- .7 Accessories: Base caps and base divider strips, purpose made and of same material to match divider strips.
- .8 Slip sheet: polyethylene sheet to CAN2-51.33-M80, type 3, 0.05mm (0.002") thick.
- .9 Cleaning, sealing, finishing compounds: To TTMAC Standard 1001, 2001, 3001.
- .10 Epoxy bonding agent: To TTMAC Standard.

2.2. Mixes

- .1 Underbed: 1 part cement to 4 parts sand by volume
- .2 Terrazzo topping: To match existing colour(s).

PART 3 – EXECUTION

3.1 Installation

- .1 Apply terrazzo after concrete slabs have cured 28 days.
- .2 On existing concrete slabs, complete remove all existing adhesives and/or toppings, scarify slab to ensure mechanical bond of terrazzo base course.
- .3 Terrazzo infills/ repairs are to be taken to nearest divider strip, so that complete panels are replaced.**
- .4 Install divider strips true and level to 1000mm x 1000mm (40" x 40") maximum.
- .5 Install covers at building expansion joints.
- .6 Slope finished terrazzo floors 1% to drains.
- .7 Produce terrazzo finished surfaces consisting of 70% of marble chips to match existing colour(s).

3.2 Floors

- .1 Epoxy bonded terrazzo: To TTMAC Detail No. 1A; 16mm (0.625") thickness.

3.3 Sealing

- .1 Clean, seal and finish terrazzo surfaces to TTMAC recommendations.

END OF SECTION

CONSTRUCTION ASSEMBLY LEGEND

- NOTES:**
- THESE WALL TYPES ARE APPLICABLE TO TYPICAL WALL CONDITIONS ON ALL FLOOR PLANS. THERE ARE EXCEPTIONS THAT ARE NOTED / DETAILED IN THESE DOCUMENTS.
 - ALL WALL HEIGHTS ARE TO UNDERSIDE OF STRUCTURE ABOVE (BOTTOM CHORD, METAL DECK, ETC.) UNLESS NOTED OR DETAILED OTHERWISE.
 - WHERE INDICATED ON FLOOR PLAN CONSTRUCTION MATERIALS / WALL ASSEMBLY TO COMPLY WITH REQUIRED FIRE RESISTANCE RATING. JOINTS TO BE SEALED CONTINUOUS AND BE FIRE STOPPED TO PREVENT THE PASSAGE OF SMOKE.
 - REPAIR EXISTING WALLS WHERE REQUIRED. MAKE GOOD TO RECEIVE NEW MATERIALS AND FINISHES. REFER TO ROOM FINISH SCHEDULE.
 - WHERE EXISTING WALL CONSTRUCTION IS BEING INFILLED WITH NEW WALL CONSTRUCTION, THE FACE OF NEW WALL FINISHES ARE TO ALIGN WITH THE FACE OF THE EXISTING WALL FINISHES.

EXTERIOR WALL TYPES

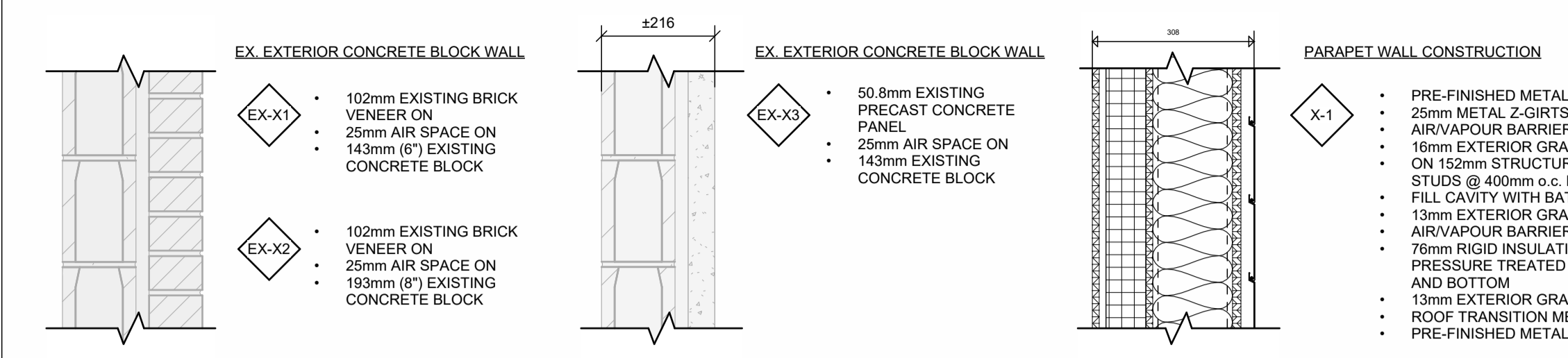

INTERIOR WALL TYPES

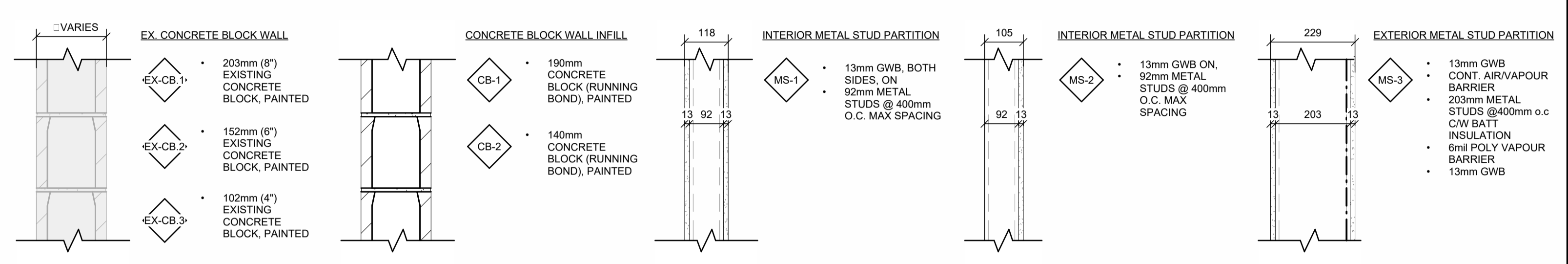

ROOF CONSTRUCTION

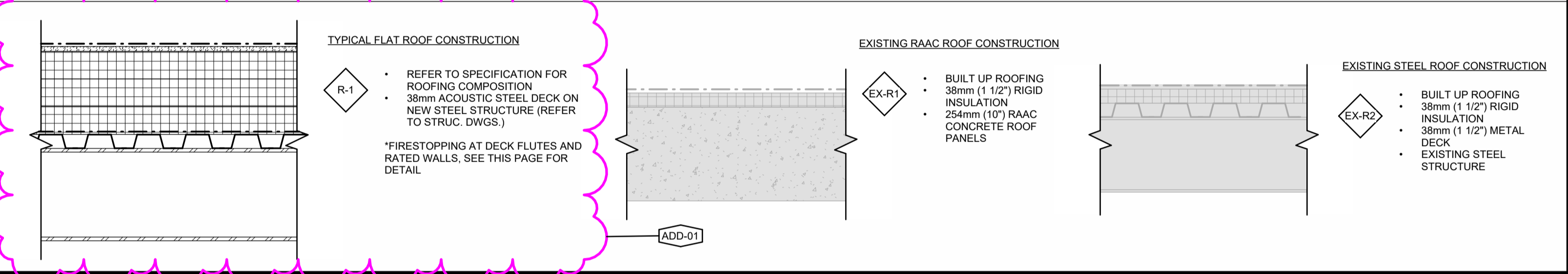

GENERAL NOTES

- THIS LEGEND IS APPLICABLE TO ALL DRAWINGS**
- CONTRACTOR TO VERIFY DIMENSIONS ON SITE AND REPORT ALL DISCREPANCIES TO THE ARCHITECT PRIOR TO PROCEEDING.
 - REFER TO FLOOR PLANS FOR FIRE SEPARATION LOCATIONS. CARRY ALL PARTITIONS TO UNDERSIDE OF STRUCTURAL PRECAST SLABS OR METAL DECK UNLESS NOTED OR DETAILED OTHERWISE.
 - FIRE STOP ALL JOINTS AND PENETRATIONS IN FIRE SEPARATIONS.
 - INTERIOR DIMENSIONS ARE FROM FACE OF CONCRETE BLOCK TO FACE OF CONCRETE BLOCK OR FACE OF GYP. WALL BOARD TO FACE OF GYP. WALL BOARD.
 - REFER TO OVERALL FLOOR PLANS FOR FIRE SEPARATIONS.
 - FIRE STOP ALL JOINTS AND PENETRATIONS IN FIRE SEPARATIONS.
 - SLOPE NEW FLOORS 1.5% TO DRAINS.
 - ALL CONCRETE BLOCK TO BE LIGHT WEIGHT.
 - PROVIDE SOLID WOOD BLOCKING BEHIND ALL WASHROOM ACCESSORIES & DOOR HARDWARE IN METAL STUD PARTITIONS.
 - PROVIDE SOLID WOOD BLOCKING BEHIND ALL WASHROOM ACCESSORIES AND DOOR HARDWARE.
 - INFILL ALL EXISTING MECHANICAL OPENINGS WITH NEW BLOCK TO MATCH EXISTING. COORDINATE WITH MECHANICAL DEMOLITION PLANS.
 - USE MOISTURE RESISTANT GWB IN ALL WASHROOMS, SHOWER ROOMS, AND KITCHEN AREAS.
 - ALL INTERIOR CONCRETE BLOCK TO HAVE BULLNOSE CORNERS. TYPICAL IN ALL LOCATIONS UNLESS NOTED OTHERWISE.
 - ALL WALLS TO BE CONSTRUCTED AS 0-HOUR FIRE SEPARATIONS UNLESS NOTED OTHERWISE.
 - ALL PARTITIONS TO CARRY OVER OPENINGS UNLESS NOTED OTHERWISE.
 - CONTRACTOR TO RESTORE ALL AREAS DISTURBED BY CONSTRUCTION.
 - TOOTH-IN NEW CONCRETE BLOCK WITH EXISTING CONCRETE BLOCK. NEW CONCRETE BLOCK TO MATCH EXISTING CONCRETE BLOCK IN EXISTING WALL UNLESS NOTED OTHERWISE.
 - ALL DOORS INSTALLED 100mm FROM WALL ON HINGE SIDE UNLESS NOTED OTHERWISE.

DOOR ELEVATIONS

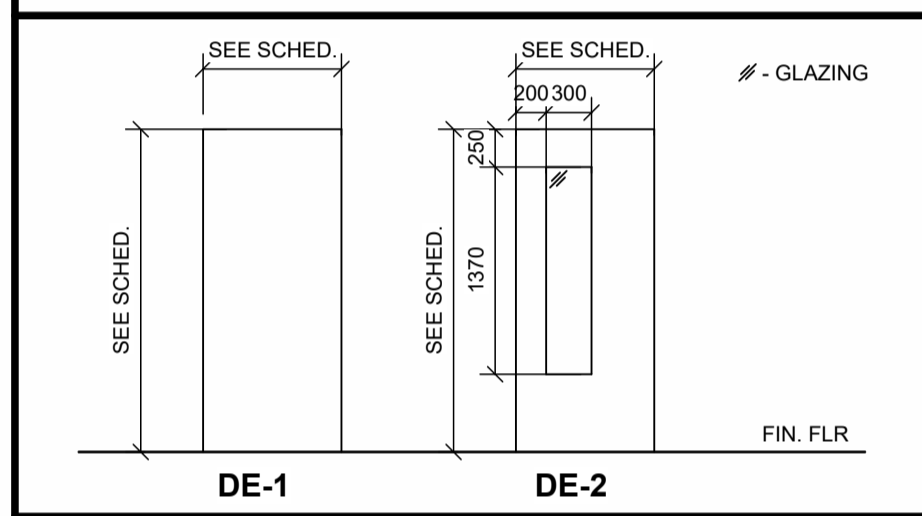

ROOM FINISH SCHEDULE

NO.	ROOM NAME	FLOOR		NORTH		EAST		SOUTH		WEST		CEILING		REMARKS
		FM	FF	WM	WF	WM	WF	WM	WF	WM	WF	CM	CF	
FL 1.0														
1	EXISTING CLASSROOM	EX	RSF	RB	EX / CB	P	EX / CB / GB	P	EX	P	EX / CB	P	ACT / GB	- / P
2	CLOSET	EX	RSF	RB	EX / CB	P	EX / CB / GB	P	EX	P	EX / CB	P	ACT / GB	- / P
3	EXISTING CLASSROOM	EX	RSF	RB	EX / CB	P	EX / CB / GB	P	EX	P	EX / CB	P	ACT / GB	- / P
4	EXISTING CLASSROOM	EX	RSF	RB	EX / CB	P	EX / CB / GB	P	EX	P	EX / CB	P	ACT / GB	- / P
5	EXISTING CLASSROOM	EX	RSF	RB	EX / CB	P	EX / CB / GB	P	EX	P	EX / CB	P	ACT / GB	- / P
6	CLOSET	EX	RSF	RB	EX / CB	P	EX / CB / GB	P	EX	P	EX / CB	P	ACT / GB	- / P
7	EXISTING CLASSROOM	EX	RSF	RB	EX / CB	P	EX / CB / GB	P	EX	P	EX / CB	P	ACT / GB	- / P
8	CLOSET	EX	RSF	RB	EX / CB	P	EX / CB / GB	P	EX	P	EX / CB	P	ACT / GB	- / P
9	EXISTING CLASSROOM	EX	RSF	RB	EX / CB	P	EX / CB / GB	P	EX	P	EX / CB	P	ACT / GB	- / P
10	EXISTING CLASSROOM	EX	RSF	RB	EX / CB	P	EX / CB / GB	P	EX	P	EX / CB	P	ACT / GB	- / P
11	EXISTING CLASSROOM	EX	RSF	RB	EX / CB	P	EX / CB / GB	P	EX	P	EX / CB	P	ACT / GB	- / P
12	EXISTING CLASSROOM	EX	RSF	RB	EX / CB	P	EX / CB / GB	P	EX	P	EX / CB	P	ACT / GB	- / P
129	EXISTING BOY'S WASHROOM	EX	EX / TERR	EX / TERR	EX / CB	P	EX / CB	P	EX	P	EX / CB	P	ACT	- PATCH AND REPAIR TERRAZZO AT FLOOR CUTS
130	EXISTING STORAGE	EX	EX / TERR	EX / TERR	EX / CB	P	EX / CB	P	EX	P	EX / CB	P	ACT	- PATCH AND REPAIR TERRAZZO AT FLOOR CUTS
131	EXISTING GIRL'S WASHROOM	EX	EX / TERR	EX / TERR	EX / CB	P	EX / CB	P	EX	P	EX / CB	P	ACT	- PATCH AND REPAIR TERRAZZO AT FLOOR CUTS
132	EXISTING CORRIDOR	EX	EX / TERR	EX / TERR	EX / CB	P	EX / CB	P	EX	P	EX / CB	P	ACT	- PATCH AND REPAIR TERRAZZO AT FLOOR CUTS
133	EXISTING VESTIBULE	EX	EX / TERR	EX / TERR	EX	P	EX	P	EX	P	EX	P	ACT	- PATCH AND REPAIR TERRAZZO AT FLOOR CUTS

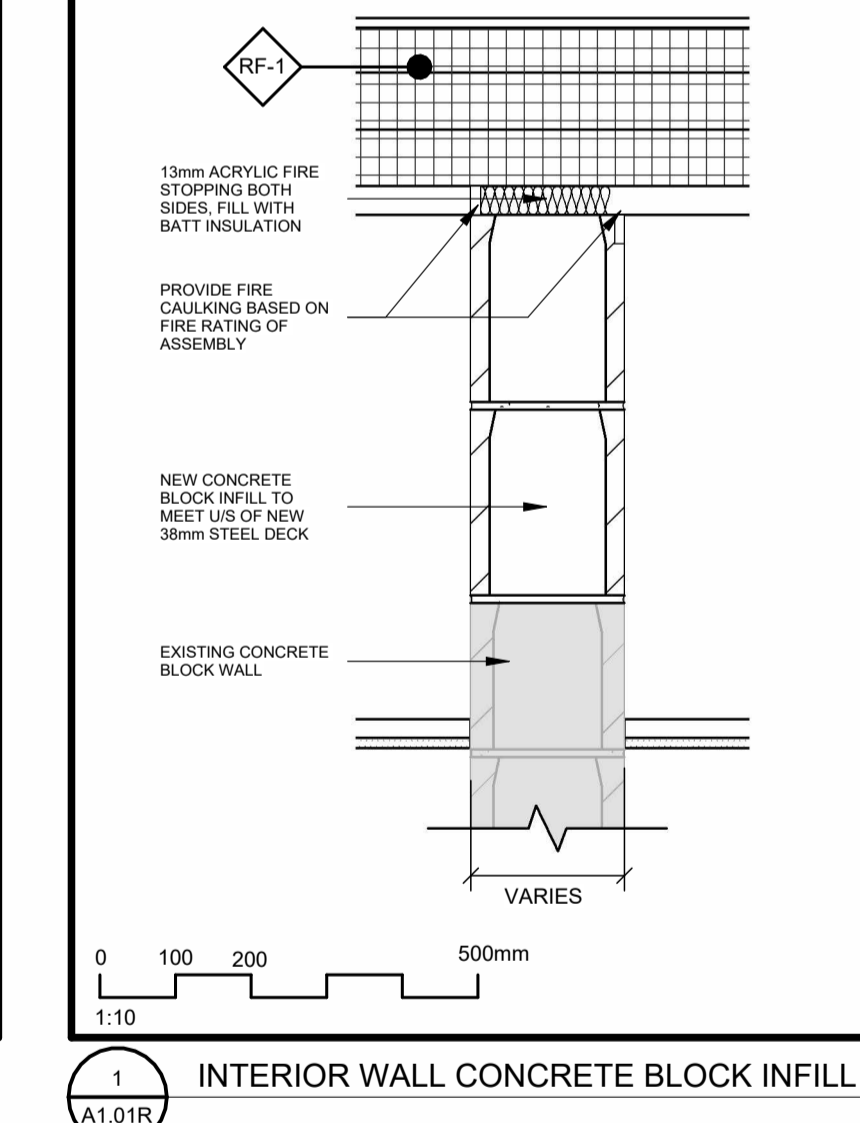
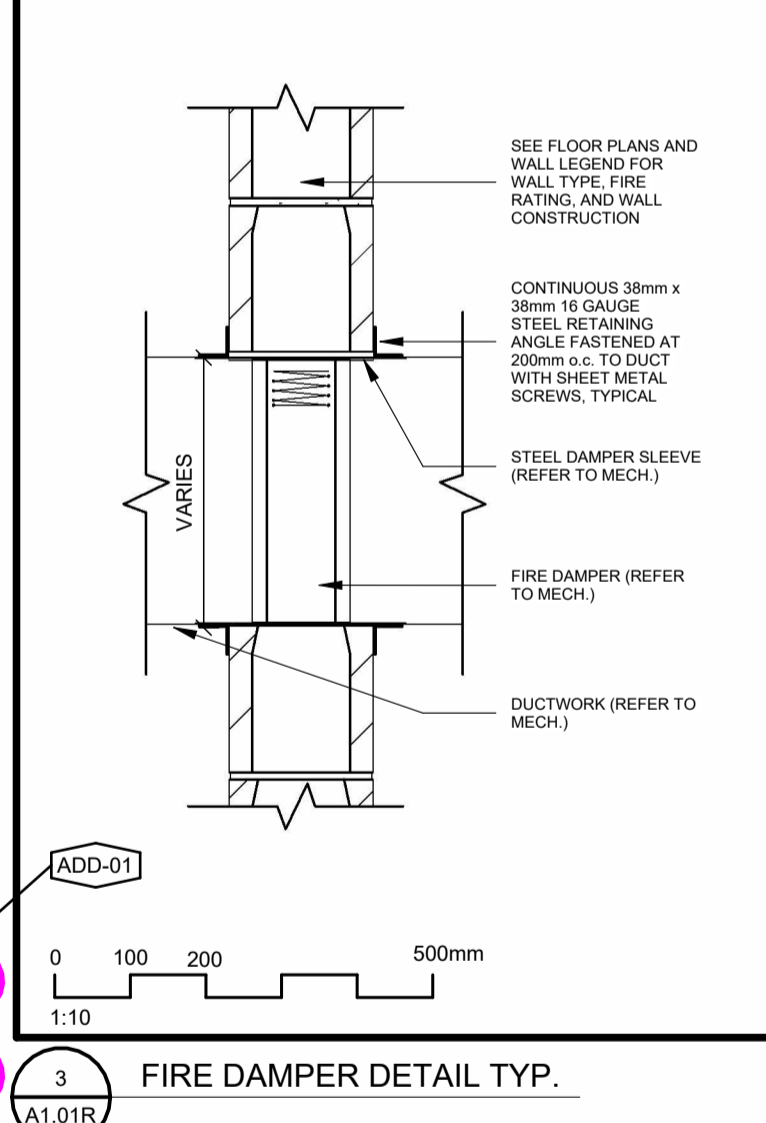

DOOR & FRAME SCHEDULE

LEGEND

DE DOOR ELEVATION DM DOOR MATERIAL FF FRAME FINISH FRG FIRE RATED GLASS min. MINUTE

DF DOOR FINISH FE FRAME ELEVATION FM FRAME MATERIAL HM HOLLOW METAL P PAINT

NOTE: SITE CONFIRM DIMENSIONS OF ALL NEW DOORS AND EXISTING FRAMES

NO.	SIZE	DOOR		GLASS	LABEL	FRAME		HANDLE		HARDWARE		REMARKS
		DE	DM			FE	FM	FF	CLOSER	LOCK		
FL 1.0												
1-01	915x2134x45	DE-2	HM	P	FRG	30 min.	EX	EX	P	LEVER	NO	YES
1-02	610x2134x45	DE-1	HM	P	FRG	30 min.	EX	EX	P	LEVER	NO	YES
2-01	915x2134x45	DE-2	HM	P	FRG	30 min.	EX	EX	P	LEVER	NO	YES
2-02	610x2134x45	DE-1	HM	P	FRG	30 min.	EX	EX	P	LEVER	NO	YES
3-01	915x2134x45	DE-2	HM	P	FRG	30 min.	EX	EX	P	LEVER	NO	YES
3-02	610x2134x45	DE-1	HM	P	FRG	30 min.	EX	EX	P	LEVER	NO	YES
4-01	915x2134x45	DE-2	HM	P	FRG	30 min.	EX	EX	P	LEVER	NO	YES
4-02	610x2134x45	DE-1	HM	P	FRG	30 min.	EX	EX	P	LEVER	NO	YES
5-01	915x2134x45	DE-2	HM	P	FRG	30 min.	EX	EX	P	LEVER	NO	YES
5-02	610x2134x45	DE-1	HM	P	FRG	30 min.	EX	EX	P	LEVER	NO	YES
9-01	915x2134x45	DE-2	HM	P	FRG	30 min.	EX	EX	P	LEVER	NO	YES
9-02	610x2134x45	DE-1	HM	P	FRG	30 min.	EX	EX	P	LEVER	NO	YES
10-01	915x2134x45	DE-2	HM	P	FRG	30 min.	EX	EX	P	LEVER	NO	YES
10-02	610x2134x45	DE-1	HM	P	FRG	30 min.	EX	EX	P	LEVER	NO	YES
11-01	915x2134x45	DE-2	HM	P	FRG	30 min.	EX	EX	P	LEVER	NO	YES
11-02	610x2134x45	DE-1	HM	P	FRG	30 min.	EX	EX	P	LEVER	NO	YES
129-02	915x2134x45	DE-1	HM	P	FRG	30 min.	EX	EX	P	LEVER	YES	YES
130-02	915x2134x45	DE-1	HM	P	FRG	30 min.	EX	EX	P	LEVER	YES	YES
131-02	915x2134x45	DE-1	HM	P	FRG	30 min.	EX	EX	P	LEVER	YES	YES

ABBREVIATIONS

NOTES, LEGENDS, & ABBREVIATIONS ARE APPLICABLE TO ALL DRAWINGS

ACF ARCHITECTURAL CONCRETE FINISH	D.F. DRINKING FOUNTAIN	HB HOSE BIB	RD ROOF DRAIN
AESS ARCHITECTURAL EXPOSED STEEL	DW DISH WASHER	HDG HOT DIPPED GALVANIZED	RTU ROOF TOP UNIT
AFF ABOVE FINISHED FLOOR	DWG DRAWING	HM HOLLOW METAL	RWL RAIN WATER LEADER
ALUM ALUMINUM	EJ EXPANSION JOINT	INSUL INSULATION	SNL SANITARY NAPKIN DISPENSER
ARCH ARCHITECTURAL	ELEC ELECTRICAL	LKR LOCKER	SHWR SHOWER
AT ACOUSTIC TILE	ELEV ELEVATOR	MECH MECHANICAL	SPEC SPECIFICATIONS
AV AIR VAPOUR BARRIER	EP ELECTRICAL PANEL	MFG MANUFACTURER	STL STEEL
B.F. BARRIER FREE	E-TEL EMERGENCY TELEPHONE	MICRO MICROWAVE (OWNER SUPPLIED)	STRUC STRUCTURAL
BLKF BELOW FINISHED FLOOR	EXIST EXISTING	MIN MINIMUM	TB TOWEL BAR
BLKHD BULKHEAD	EXT EXTERIOR	MIRR MIRROR	TD TRENCH DRAIN
CB CATCH BASIN	FEX FIRE EXTINGUISHER	mm MILLIMETRES	T/O TOP OF
CBLK CONCRETE BLOCK	F FRIDGE (OWNER SUPPLIED)	MOP MOP SINK	TTD TOILET TISSUE DISPENSER
CC CENTRE TO CENTRE	F-EJ FLOOR EXPANSION JOINT	MR MOISTURE RESISTANT	TV TELEVISION (OWNER SUPPLIED)
CIP CAST-IN-PLACE	FD FLOOR DRAIN	MW MILLWORK	TWF THROUGH WALL FLASHING
CJ CONTROL JOINT	FG FLOOR GRILLE	N.I.C. NOT IN CONTRACT	TYP TYPICAL
CLG CEILING	FHC FIRE HOSE CABINET	O.C. ON CENTRE	UIS UNDERSIDE
CONC CONCRETE	FIN FINISH	PDO POWER DOOR OPERATOR	VCT VINYL COMPOSITE TILE
CONT CONTINUOUS	FL FIRE LITE GLAZING	PREFIN PREFINISHED	W WASHING MACHINE
c/w COMPLETE WITH	GB GRAB BAR	PVB POLY VAPOUR BARRIER	W-EJ WALL EXPANSION JOINT
D DRYER	GMWB GLASS MAT GYPSUM BOARD	QT QUARTZ TILE	WT WEEPING TILE
DIA DIAMETER	GYP BD GYPSUM BOARD	RFX RECESSED FIRE EXTINGUISHER	w WITH



Name of Practice: Cornerstone Architecture Incorporated
102-320 Thames Street London, ON N6A 0E1
Tel: (519) 432-6644 Fax: (519) 432-6737

Name of Project: CRESTVIEW PUBLIC SCHOOL ROOF REPLACEMENT
Project Location: 153 MONTCALM DRIVE, KITCHENER, ONTARIO, N2B 2R6

ITEM	ONTARIO BUILDING CODE DATA MATRIX PART 11	O.B.C. REFERENCE
11.01	Project Type: <input type="checkbox"/> New <input type="checkbox"/> Addition <input checked="" type="checkbox"/> Renovation <input type="checkbox"/> Change of Use <input type="checkbox"/> Addition & Renovation Description: RAAC ROOF DECK REPLACEMENT & INTERIOR ALTERATIONS	PART 11 [A] 1.1.2
11.02	Major Occupancy (s): GROUP A, DIVISION 2 ELEMENTARY SCHOOL	3.1.2.1. (1)
11.03	Superimposed Major Occupancies: <input type="checkbox"/> YES <input checked="" type="checkbox"/> NO Description: N/A	3.2.2.7
11.04	Building Area (m²): Existing: 4,678 m² New: 0 m² Total: 4,678 m²	[A] 1.4.1.2
11.05	Number of Storeys: Above Grade: 1 Below Grade: 0 Height of Building (m): 3.3430 m	[A] 1.4.1.1 3.2.1.1
11.06	Number of Streets / Fire Fighters Access Routes: 1	3.2.2.10 & 3.2.5
11.07	Building Size: <input type="checkbox"/> Small <input type="checkbox"/> Medium <input checked="" type="checkbox"/> Large <input type="checkbox"/> Large	Table 11.2.1.1.B - N
11.08	Existing Building Construction: Change in Major Occupancy: <input type="checkbox"/> YES <input checked="" type="checkbox"/> Not Applicable (No Change in Major Occupancy)	11.2.1.1 Table 11.2.1.1.A Table 11.2.1.1.B - N 4.2.1.(3) 5.2.2.1.(2)
11.09	Renovation Type: <input checked="" type="checkbox"/> Basic Renovation <input type="checkbox"/> Extensive Renovation	11.3.3.1 & 11.3.3.2
11.10	Occupant Load based on: Total Occupant Load: EXISTING (no change)	3.1.17
11.11	Plumbing Fixture Requirements: Occupant Load: EXISTING (no change) RATIO: EXISTING MALE: EXISTING EXISTING REQUIRED EXISTING PROVIDED EXISTING FEMALE: EXISTING EXISTING EXISTING EXISTING	3.7.4
11.12	Barrier-free Design: <input checked="" type="checkbox"/> YES <input type="checkbox"/> NO (EXPLAIN)	11.3.3.2.(2)
11.13	Reduction in Performance Level: Structural: <input type="checkbox"/> YES <input checked="" type="checkbox"/> NO By Increase in Occupant Load: <input type="checkbox"/> YES <input checked="" type="checkbox"/> NO Gy Change in Major Occupancy: <input type="checkbox"/> YES <input checked="" type="checkbox"/> NO Plumbing: <input type="checkbox"/> YES <input checked="" type="checkbox"/> NO Sewage-Systems: <input type="checkbox"/> YES <input checked="" type="checkbox"/> NO Extension of Combustible Construction: <input type="checkbox"/> YES <input checked="" type="checkbox"/> NO	11.4.2.1 11.4.2.2 11.4.2.3 11.4.2.4 11.4.3.5 11.4.3.6 11.4.3.7
11.14	Compensating Construction: <input type="checkbox"/> YES <input checked="" type="checkbox"/> NO Structural: <input type="checkbox"/> YES <input checked="" type="checkbox"/> NO (Describe) By Increase in Occupant Load: <input type="checkbox"/> YES <input checked="" type="checkbox"/> NO (Describe) Gy Change in Major Occupancy: <input type="checkbox"/> YES <input checked="" type="checkbox"/> NO (Describe) Plumbing: <input type="checkbox"/> YES <input checked="" type="checkbox"/> NO (Describe) Sewage-Systems: <input type="checkbox"/> YES <input checked="" type="checkbox"/> NO (Describe) Extension of Combustible Construction: <input type="checkbox"/> YES <input checked="" type="checkbox"/> NO (Describe)	11.4.3.1 11.4.3.2 11.4.3.3 11.4.3.4 11.4.3.5 11.4.3.6 11.4.3.7
11.15	Compliance Alternatives Proposed: <input type="checkbox"/> YES <input checked="" type="checkbox"/> NO List numbers and describe	11.5.1
11.16	Notes: NOT SPRINKLERED (EXISTING)	11.5.1

SYMBOL LEGEND APPLICABLE TO ALL DRAWINGS

ROOM NAME 101	ROOM NAME/NUMBER (SEE ROOM FINISH SCHEDULE)	0	EXISTING GRID LINE
101	DOOR/INTERIOR WINDOW NUMBER (SEE DOOR & FRAME SCHEDULE)	1 Ref	SECTION / DETAIL NUMBER
101		A101	DRAWING SHEET NUMBER LOCATION
XX.X	CONSTRUCTION ASSEMBLY TYPE (SEE ASSEMBLY LEGENDS ON DRAWING A0.01)	PD	BARRIER FREE POWER DOOR OPERATOR
AX.XX	INTERIOR WALL ELEV. IDENTIFICATION NUMBER	↘	DENOTES SLOPE OF ROOF
	MILLWORK - (SEE INTERIOR ELEVATIONS & MILLWORK DETAILS IN SPEC)	EP	RECESSED ELECTRICAL PANEL (SEE ELECTRICAL DWG'S)

102-320 Thames Street London, Ontario N6A 0E1
P 519 432 6644 F 519 432 6737
cornerstonearchitecture.ca

© 2026 Cornerstone Architecture Incorporated. All Rights Reserved.

CORNERSTONE
ARCHITECTURE

WATERLOO REGION DISTRICT SCHOOL BOARD

153 Montcalm Dr., Kitchener, ON
Project No.: 1167B
Drawn By: CAI
Plot Date: 2026-03-27

CRESTVIEW PUBLIC SCHOOL
RAAC Roof Deck Replacement & Interior Alterations

OBC DATA, BUILDING ELEMENTS, OVERALL SITE PLAN, & GENERAL NOTES

A1.01R