

# Appendix B

---

## Figures

For Tender Purposes

\*\*\*REFER TO APPENDIX A: ASBESTOS MANAGEMENT DATABASE FOR FULL LIST OF ASBESTOS-CONTAINING MATERIALS (ACM).  
 \*\*\*ALL ACM MAY NOT BE DEPICTED IN THIS FIGURE.

**NOTES:**  
 ALL DRAWINGS TO BE REFERENCED WITH THE ASSOCIATED REPORT. LOCATIONS AND QUANTITIES ARE APPROXIMATE.  
 ALL KNOWN OR SUSPECT ASBESTOS-CONTAINING MATERIALS AND/OR DESIGNATED MATERIALS ARE NOT DEPICTED ON THIS DRAWING. REFER TO THE REPORT FOR A COMPLETE LIST OF IDENTIFIED MATERIALS.  
 THIS FIGURE IS COLOUR DEPENDENT. PHOTOCOPIES MAY ALTER INTERPRETATION OF THE FIGURE. ALWAYS REFER TO ORIGINAL DRAWINGS AND REPORT.

**Legend**

- 13 Fixed Reference Number
- No Access
- Post 1986 Construction

**Asbestos-Containing Materials (ACM):**

- Floor Tile
- Rollled Flooring
- Ceiling Tile (Ceiling Surface)
- Ceiling Tile (Located Above Drop Ceiling)
- Friable Soft Textured Ceiling
- Non-Friable Hard Textured Ceiling
- Spray-On Fire Proofing
- Trowel Applied Fire Proofing
- Transite (Asbestos Cement) Paneling
- Duct Insulation
- Pipe Fitting Insulation w Quantity (Brackets Indicate # of Damaged Fittings)
- Pipe Insulation (Vertical and Horizontal)
- Transite (Asbestos Cement) Pipe (Vertical and Horizontal)
- Duct Expansion Joints w Quantity (Brackets Indicate # of Damaged Joints)
- Friable Debris



Ph. (519) 743-6500 www.mte85.com

CLIENT  
 WATERLOO REGION DISTRICT SCHOOL BOARD

PROJECT  
 2021 ASBESTOS AUDIT UPDATE

DRAWING  
 WATERLOO-OXFORD DISTRICT SECONDARY SCHOOL  
 LEVEL ONE

Project Manager	P. Semeniuk	Date	October 2022 Revision
Design By	WRDSB	Project No.	34532-921
Drawn By	P. Semeniuk	Drawing No.	1.0
Scale	N.T.S.		

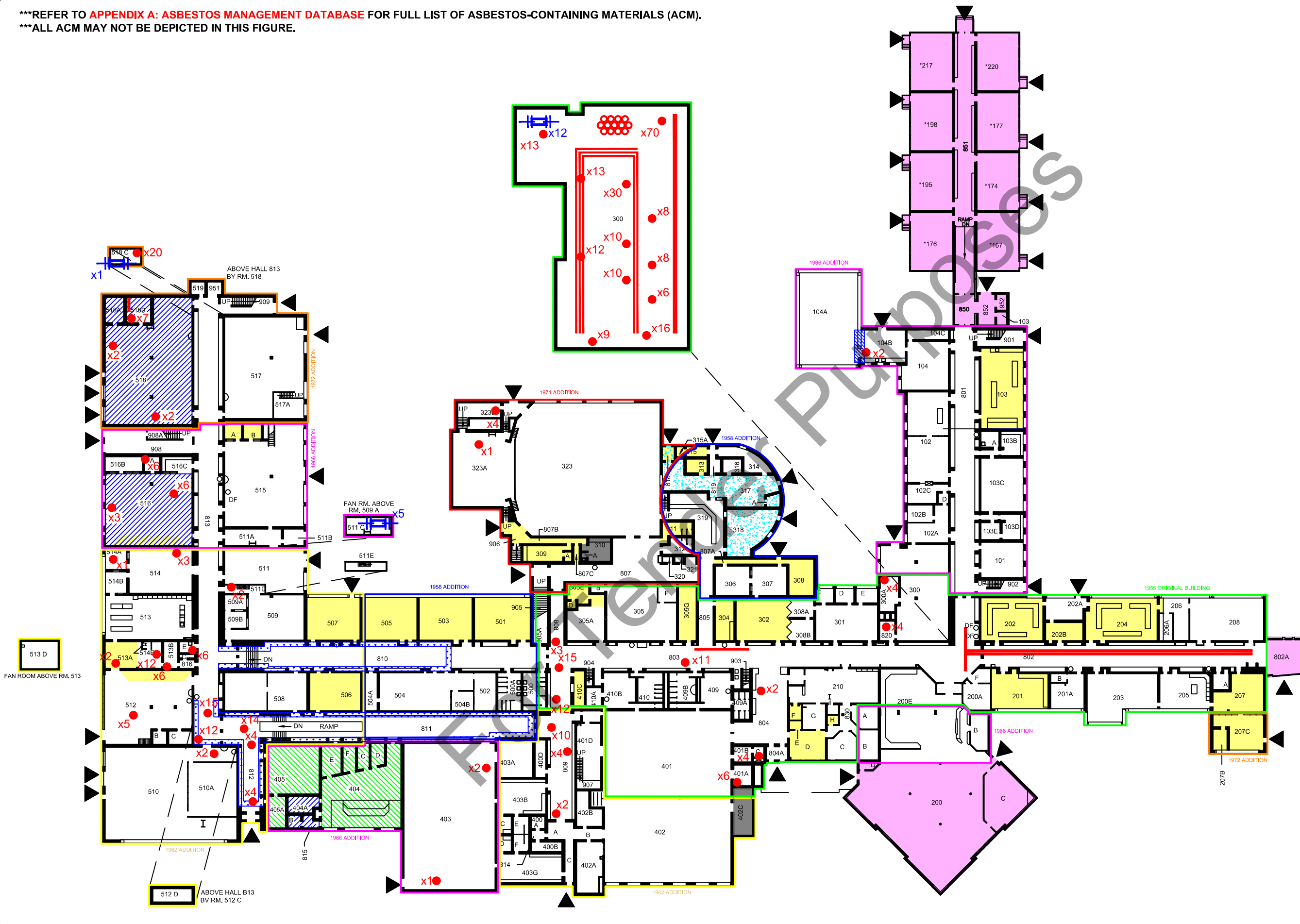



# Appendix C

---

## Tables

For Tender Purposes









TABLE 1 - INTERNAL ABATEMENT MANAGEMENT						
Waterloo Oxford Secondary School						
Material	WRDSB Fixed Reference Number	Material Description	Approximate Quantity	Photograph - Context	Photograph - Detail	Required Action
Asbestos Non-Friable	103	9" x 9" Tan Floor Tile	2 tiles			Monitor Annually
Asbestos Non-Friable	125	9" x 9" Green Floor Tile	5 Tiles			Monitor Annually
Asbestos Non-Friable	200	Drywall	<1 m <sup>2</sup>			Monitor Annually
Asbestos Non-Friable	200	Drywall	<1 m <sup>2</sup>			Monitor Annually

Table 1 and 2 - Damaged Materials - Waterloo Oxford District Secondary School









TABLE 1 - INTERNAL ABATEMENT MANAGEMENT						
Waterloo Oxford Secondary School						
Material	WRDSB Fixed Reference Number	Material Description	Approximate Quantity	Photograph - Context	Photograph - Detail	Required Action
Asbestos Non-Friable	207	12"x12" beige Floor Tiles cracking and degrading at floor seam	40 tiles			Removal in accordance with O. Reg. 278/05 as a Type 1 Operation
Asbestos Non-Friable	101, 102, 102A, 102B, 103, 103C, 103F, 104, 122, 124, 126, 128	1' x 1' Ceiling Tiles - Damage at hangers and penetrations	Throughout			Monitor Annually
Asbestos Non-Friable	404B	1' x 1' Ceiling Tiles	19 tiles			Removal in accordance with O. Reg. 278/05 as a Type 1 Operation
Asbestos Non-Friable	802 at room 206	Drywall	<1 m <sup>2</sup>			Monitor Annually

Table 1 and 2 - Damaged Materials - Waterloo Oxford District Secondary School









TABLE 1 - INTERNAL ABATEMENT MANAGEMENT						
Waterloo Oxford Secondary School						
Material	WRDSB Fixed Reference Number	Material Description	Approximate Quantity	Photograph - Context	Photograph - Detail	Required Action
Asbestos Non-Friable	807B	12"x12" orange Floor Tiles	3 Tiles			Monitor Annually
Asbestos Non-Friable	809	2' x 2' Ceiling Tiles - Dense Fissure Random Pinhole	15+ Tiles			Removal in accordance with O. Reg. 278/05 as a Type 1 Operation
Asbestos Non-Friable	822	Exposed Mastic	14 tiles			Repair/Removal in accordance with O. Reg. 278/05 as a Type 1 Operation
Asbestos Non-Friable	906	12"x12" orange Floor Tiles	2 Tiles			Monitor Annually

Table 1 and 2 - Damaged Materials - Waterloo Oxford District Secondary School

TABLE 1 - INTERNAL ABATEMENT MANAGEMENT						
Waterloo Oxford Secondary School						
Material	WRDSB Fixed Reference Number	Material Description	Approximate Quantity	Photograph - Context	Photograph - Detail	Required Action
<p>Notes:</p> <p>1) A copy of this report should be provided to all prospective contractors prior to tender or quotation, in accordance with Section 30 of the Occupational Health and Safety Act.</p> <p>2) Recommended actions are the minimum required actions, as prescribed by the appropriate Acts, regulations, guidelines, standards, codes and general best practice measures. The Contractor may choose to alter the approach and combine or break out sections of work. This is acceptable provided that the appropriate Acts, regulations, guidelines, standards and codes are followed and afford protection for the health and safety of workers, occupants and the public that is at least equal to the protection that would be provided by complying with the minimum requirements.</p> <p>3) All waste generated is subject to characterization and disposal in accordance with Ontario Regulation 347.</p>						

For Tender Purposes









TABLE 2 - EXTERNAL ABATEMENT MANAGEMENT						
Waterloo Oxford Secondary School						
Material	WRDSB Fixed Reference Number	Material Description	Approximate Quantity	Photograph - Context	Photograph - Detail	Required Action
Asbestos Friable	104B	Insulation on Pipe Fittings	2			Removal in accordance with O. Reg. 278/05 as a Type 2 Operation
Asbestos Friable	300	Insulation on Pipe Fittings	2			Removal in accordance with O. Reg. 278/05 as a Type 2 Operation
Asbestos Friable	300	Insulation on Pipe Fittings	1			Removal in accordance with O. Reg. 278/05 as a Type 2 Operation
Asbestos Friable	300	Insulation on Pipe Fittings	1			Removal in accordance with O. Reg. 278/05 as a Type 2 Operation

Table 1 and 2 - Damaged Materials - Waterloo Oxford District Secondary School











TABLE 2 - EXTERNAL ABATEMENT MANAGEMENT						
Waterloo Oxford Secondary School						
Material	WRDSB Fixed Reference Number	Material Description	Approximate Quantity	Photograph - Context	Photograph - Detail	Required Action
Asbestos Friable	300	Insulation on Pipe Fittings	1			Removal in accordance with O. Reg. 278/05 as a Type 2 Operation
Asbestos Friable	300	Insulation on Pipe Fittings	2			Removal in accordance with O. Reg. 278/05 as a Type 2 Operation
Asbestos Friable	300	Insulation on Pipe Fittings	1			Removal in accordance with O. Reg. 278/05 as a Type 2 Operation
Asbestos Friable	300	Insulation on Pipe Fittings	1			Removal in accordance with O. Reg. 278/05 as a Type 2 Operation

Table 1 and 2 - Damaged Materials - Waterloo Oxford District Secondary School

TABLE 2 - EXTERNAL ABATEMENT MANAGEMENT						
Waterloo Oxford Secondary School						
Material	WRDSB Fixed Reference Number	Material Description	Approximate Quantity	Photograph - Context	Photograph - Detail	Required Action
Asbestos Friable	300	Insulation on Pipe Fittings	1			Removal in accordance with O. Reg. 278/05 as a Type 2 Operation
Asbestos Non-Friable	518	2" x4" Ceiling Tiles	30+ Tiles			Removal in accordance with O. Reg. 278/05 as a Type 2 Operation

Notes:

- 1) A copy of this report should be provided to all prospective contractors prior to tender or quotation, in accordance with Section 30 of the Occupational Health and Safety Act.
- 2) Recommended actions are the minimum required actions, as prescribed by the appropriate Acts, regulations, guidelines, standards, codes and general best practice measures. The Contractor may choose to alter the approach and combine or break out sections of work. This is acceptable provided that the appropriate Acts, regulations, guidelines, standards and codes are followed and afford protection for the health and safety of workers, occupants and the public that is at least equal to the protection that would be provided by complying with the minimum requirements.
- 3) All waste generated is subject to characterization and disposal in accordance with Ontario Regulation 347.

Table 1 and 2 - Damaged Materials - Waterloo Oxford District Secondary School

TABLE 3: BULK ASBESTOS SAMPLING SUMMARY					
Sample #	WRDSB Fixed Reference Number	Material Description	Asbestos Content (%)	Fibre Type	Is Material ACM
<b>2008 Asbestos Audit Update</b>					
32523-WOHS S01A	518	Drywall - Joint Compound	ND	-	No
32523-WOHS S01B			ND	-	No
32523-WOHS S01C			ND	-	No
32523-WOHS S02A	518	Plaster - White/Off-White	ND	-	No
32523-WOHS S02B			ND	-	No
32523-WOHS S02C	513		ND	-	No
32523-WOHS S02D			ND	-	No
32523-WOHS S02E		ND	-	No	
32523-WOHS S03A	518	2' x 4' Ceiling Tile	1.7 0.6	Amosite Chrysotile	Yes
32523-WOHS S03B	518		NA	Amosite Chrysotile	Yes
32523-WOHS S03C	518		NA	Amosite Chrysotile	Yes
32523-WOHS S04A	908	1x1 Ceiling Tile - Large and Small Pinhole	ND	-	No
32523-WOHS S04B			ND	-	No
32523-WOHS S04C			ND	-	No
32523-WOHS S05A	513	Plaster - White/Off-White	ND	-	No
32523-WOHS S05B	513		ND	-	No
32523-WOHS S05C	513		ND	-	No
32523-WOHS S05D	513		ND	-	No
32523-WOHS S05E	509		ND	-	No
32523-WOHS S06A	513		Insulation - Fire Spray on beams and columns	4.1	Chrysotile
32523-WOHS S06B		NA		Chrysotile	Yes
32523-WOHS S06C		NA		Chrysotile	Yes
32523-WOHS S07A	516	Drywall - Joint Compound	1.8	Chrysotile	Yes
32523-WOHS S07B			1.7	Chrysotile	Yes
32523-WOHS S07C			1.8	Chrysotile	Yes
32523-WOHS S08A			516	Ceiling Finish - Texture Coat on Columns	ND
32523-WOHS S08B	ND	-			No
32523-WOHS S08C	ND	-			No
32523-WOHS S09A	515	9"x9" Floor Tile - Brown with White Fleck	Layer 1: 1.3 Layer 2: ND	Chrysotile -	Yes -
32523-WOHS S09B			Layer 1: NA Layer 2: ND	Chrysotile -	Yes -
32523-WOHS S09C			Layer 1: NA Layer 2: ND	Chrysotile -	Yes -
32523-WOHS S10A	509	1x1 Ceiling Tile - Large Pinhole	ND	-	No
32523-WOHS S10B			ND	-	No
32523-WOHS S10C			ND	-	No
32523-WOHS S11A	509	1x1 Ceiling Tile - Long Fissure Small Pinhole	ND	-	No
32523-WOHS S11B			ND	-	No
32523-WOHS S11C			ND	-	No
32523-WOHS S12A	516	1x1 Ceiling Tile - Medium and Small Pinhole	2.1	Amosite	Yes
32523-WOHS S12B			NA	Amosite	No
32523-WOHS S12C			NA	Amosite	No
32523-WOHS S13A	514A	2x4 Ceiling Tile - Random Fissure Random Pinhole	ND	-	No
32523-WOHS S13B			ND	-	No
32523-WOHS S13C			ND	-	No
32523-WOHS S14A	514A FE	1x1 Ceiling Tile - Acoustic Tile	ND	-	No
32523-WOHS S14B			ND	-	No
32523-WOHS S14C			ND	-	No
32523-WOHS S15A	514B - Staff Room	12"x12" Floor Tile - Tan with Brown	Layer 1: 3.6 Layer 2: ND	Chrysotile -	Yes -
32523-WOHS S15B			Layer 1: NA Layer 2: ND	Chrysotile -	Yes -
32523-WOHS S15C			Layer 1: NA Layer 2: ND	Chrysotile -	Yes -
32523-WOHS S16A	514B - Lunch Room	12"x12" Floor Tile - Tan with Grey/Brown Specks	ND	-	No
32523-WOHS S16B			ND	-	No
32523-WOHS S16C			ND	-	No
32523-WOHS S17A	512	2x4 Ceiling Tile - Long Fissure Random Pinhole	ND	-	No
32523-WOHS S17B			ND	-	No
32523-WOHS S17C			ND	-	No

Table 3 - Sample Summary Table - Waterloo Oxford District Secondary School

TABLE 3: BULK ASBESTOS SAMPLING SUMMARY					
Sample #	WRDSB Fixed Reference Number	Material Description	Asbestos Content (%)	Fibre Type	Is Material ACM
32523-WOHS S18A	512	9"x9" Floor Tile - Grey with White/Black	Layer 1: 1.8 Layer 2: ND	Chrysotile -	Yes -
32523-WOHS S18B			Layer 1: NA Layer 2: ND	Chrysotile -	Yes -
32523-WOHS S18C			Layer 1: NA Layer 2: ND	Chrysotile -	Yes -
32523-WOHS S19A	513	Plaster - White with Tan Texture	ND	-	No
32523-WOHS S19B			ND	-	No
32523-WOHS S19C			ND	-	No
32523-WOHS S19D			ND	-	No
32523-WOHS S19E			ND	-	No
32523-WOHS S19F	801		ND	-	No
32523-WOHS S19G			ND	-	No
32523-WOHS S20A	506	9"x9" Floor Tile - Blue with White Streaks	Layer 1: 0.5 Layer 2: ND	Chrysotile -	Yes -
32523-WOHS S20B			Layer 1: NA Layer 2: ND	Chrysotile -	Yes -
32523-WOHS S20C			Layer 1: NA Layer 2: ND	Chrysotile -	Yes -
32523-WOHS S21A	507	9"x9" Floor Tile - Green with White Streak	0.5	Chrysotile	Yes
32523-WOHS S21B			NA	Chrysotile	Yes
32523-WOHS S21C			NA	Chrysotile	Yes
32523-WOHS S22A	801	Insulation - Fire Spray on beams and columns	5.0	Chrysotile	Yes
32523-WOHS S22B			NA	Chrysotile	Yes
32523-WOHS S22C			NA	Chrysotile	Yes
32523-WOHS S23A	812	Insulation - Fire Spray on beams and columns	3.2	Chrysotile	Yes
32523-WOHS S23B			NA	Chrysotile	Yes
32523-WOHS S23C			NA	Chrysotile	Yes
32523-WOHS S24A	812	Plaster - White/Tan	ND	-	No
32523-WOHS S24B			ND	-	No
32523-WOHS S24C			ND	-	No
32523-WOHS S24D			ND	-	No
32523-WOHS S24E			ND	-	No
32523-WOHS S25A	405	9"x9" Floor Tile - Beige with Grey Fleck	Layer 1: Trace Layer 2: ND	Chrysotile -	Yes -
32523-WOHS S25B			Layer 1: Trace Layer 2: ND	Chrysotile -	Yes -
32523-WOHS S25C			Layer 1: Trace Layer 2: ND	Chrysotile -	Yes -
32523-WOHS S26A	404	9"x9" Floor Tile - Tan with White/Black Fleck	Layer 1: 0.75 Layer 2: ND	Chrysotile -	Yes -
32523-WOHS S26B			Layer 1: NA Layer 2: ND	Chrysotile -	Yes -
32523-WOHS S26C			Layer 1: NA Layer 2: ND	Chrysotile -	Yes -
32523-WOHS S27A	505-501	Plaster - White/Tan	ND	-	No
32523-WOHS S27B			ND	-	No
32523-WOHS S27C			ND	-	No
32523-WOHS S27D			ND	-	No
32523-WOHS S27E			ND	-	No
32523-WOHS S28A	501	9"x9" Floor Tile - Grey with White/Black/Red Fleck	Layer 1: 4.1 Layer 2: 1.9	Chrysotile Chrysotile	Yes -
32523-WOHS S28B			Layer 1: NA Layer 2: NA	Chrysotile Chrysotile	Yes -
32523-WOHS S28C			Layer 1: NA Layer 2: NA	Chrysotile Chrysotile	Yes -
32523-WOHS S29A	Stage Entrance	2x2 Ceiling Tile Deep Fissure Small Pinhole	ND	-	No
32523-WOHS S29B			ND	-	No
32523-WOHS S29C			ND	-	No
32523-WOHS S30A	Stage Entrance	12"x12" Floor Tile - Orange with White Fleck	Layer 1: 5.0 Layer 2: ND	Chrysotile -	Yes -
32523-WOHS S30B			Layer 1: NA Layer 2: ND	Chrysotile -	Yes -
32523-WOHS S30C			Layer 1: NA Layer 2: ND	Chrysotile -	Yes -
32523-WOHS S31A	Stage Entrance	12"x12" Floor Tile - Beige with Grey Fleck	ND	-	No
32523-WOHS S31B			ND	-	No
32523-WOHS S31C			ND	-	No

Table 3 - Sample Summary Table - Waterloo Oxford District Secondary School

**TABLE 3: BULK ASBESTOS SAMPLING SUMMARY**

Sample #	WRDSB Fixed Reference Number	Material Description	Asbestos Content (%)	Fibre Type	Is Material ACM
32523-WOHS S32A	Cafeteria	12"x12" Floor Tile - Dark Beige with Brown/White Fleck	Layer 1: 0.25	Chrysotile	Yes
32523-WOHS S32B			Layer 2: 3.3	Chrysotile	Yes
32523-WOHS S32C			Layer 1: 0.5	Chrysotile	Yes
			Layer 2: NA	Chrysotile	Yes
32523-WOHS S33A	Cafeteria	Transite - Boards Cat Walk	Layer 1: NA	Chrysotile	Yes
32523-WOHS S33B			Layer 2: NA	Chrysotile	Yes
32523-WOHS S33C			35	Chrysotile	Yes
32523-WOHS S34A	Dressing Room	12"x12" Floor Tile - Green wih Black/White/Grey Fleck	NA	Chrysotile	Yes
32523-WOHS S34B			NA	Chrysotile	Yes
32523-WOHS S34C			Layer 1: 2.2	Chrysotile	Yes
			Layer 2: ND	-	-
32523-WOHS S35A	905	Plaster	Layer 1: NA	Chrysotile	Yes
32523-WOHS S35B			Layer 2: ND	-	-
32523-WOHS S35C			Layer 1: NA	Chrysotile	Yes
32523-WOHS S35D			Layer 2: ND	-	-
32523-WOHS S35E			Layer 1: NA	Chrysotile	Yes
32523-WOHS S36A	Cafeteria Hall	2' x 2' Ceiling Tile - Thin Fissure Small Pinhole	Layer 2: ND	-	-
32523-WOHS S36B			ND	-	No
32523-WOHS S36C			ND	-	No
32523-WOHS S37A	Boys Washroom (near 502)	12"x12" Floor Tile - Grey with Brown/White Fleck	Sample not received	-	No
32523-WOHS S37B			Sample not received	-	No
32523-WOHS S37C			Sample not received	-	No
32523-WOHS S38A	Servery	2' x 2' Ceiling Tile - Solid Pattern	ND	-	No
32523-WOHS S38B			ND	-	No
32523-WOHS S38C			ND	-	No
32523-WOHS S39A	Back Storage	Ceiling Finish - Texture Coat/Fire Spray on Steel Deck Only	20	Chrysotile	Yes
32523-WOHS S39B			NA	Chrysotile	Yes
32523-WOHS S39C			NA	Chrysotile	Yes
32523-WOHS S40A	Back Storage	12"x12" Floor Tile - Beige with Light Brown/White Fleck	1.3	Chrysotile	Yes
32523-WOHS S40B			NA	Chrysotile	Yes
32523-WOHS S40C			NA	Chrysotile	Yes
32523-WOHS S41A	Staff Dining	Plaster - White	ND	-	No
32523-WOHS S41B			ND	-	No
32523-WOHS S41C			ND	-	No
32523-WOHS S42A	306	12"x12" Floor Tile - White with Black Fleck	ND	-	No
32523-WOHS S42B			ND	-	No
32523-WOHS S42C			ND	-	No
32523-WOHS S43A	307	Plaster - White/Grey	ND	-	No
32523-WOHS S43B			ND	-	No
32523-WOHS S43C			ND	-	No
32523-WOHS S44A	540	12"x12" Floor Tile - Olive with White Streaks	2.4	Chrysotile	Yes
32523-WOHS S44B			NA	Chrysotile	Yes
32523-WOHS S44C			NA	Chrysotile	Yes
32523-WOHS S45A	540	1' x 1' Ceiling Tile - Thick Fissure Small Pinhole	ND	-	No
32523-WOHS S45B			ND	-	No
32523-WOHS S45C			ND	-	No
32523-WOHS S46A	537	12"x12" Floor Tile - Tan/Olive with White/Brown Specks	1.8	Chrysotile	Yes
32523-WOHS S46B			NA	Chrysotile	Yes
32523-WOHS S46C			NA	Chrysotile	Yes
32523-WOHS S47A	Kiln Room	Refractory - Inside of Kiln	ND	-	No
32523-WOHS S47B			ND	-	No
32523-WOHS S47C			ND	-	No
32523-WOHS S48A	536	9"x9" Floor Tile - Light Brown with Brown/White Fleck	1.2	Chrysotile	Yes
32523-WOHS S48B			Trace	Chrysotile	Yes
32523-WOHS S48C			ND	Chrysotile	Yes
32523-WOHS S49A	534	9"x9" Floor Tile - Dark Green with Green/White Fleck	0.75	Chrysotile	Yes
32523-WOHS S49B			NA	Chrysotile	Yes
32523-WOHS S49C			NA	Chrysotile	Yes
32523-WOHS S50A	534	2' x 4' Ceiling Tile - Dense Small Fissure Random Pinhole	ND	-	No
32523-WOHS S50B			ND	-	No
32523-WOHS S50C			ND	-	No
32523-WOHS S51A	Office (Near 534)	9"x9" Floor Tile - Grey/Tan with White Streaks	1.4	Chrysotile	Yes
32523-WOHS S51B			NA	Chrysotile	Yes
32523-WOHS S51C			NA	Chrysotile	Yes

Table 3 - Sample Summary Table - Waterloo Oxford District Secondary School

**TABLE 3: BULK ASBESTOS SAMPLING SUMMARY**

Sample #	WRDSB Fixed Reference Number	Material Description	Asbestos Content (%)	Fibre Type	Is Material ACM
32523-WOHS S52A	527	9"x9" Floor Tile - Dark Grey/Brown with Brown and White Fleck	1.2	Chrysotile	Yes
32523-WOHS S52B			NA	Chrysotile	Yes
32523-WOHS S52C			NA	Chrysotile	Yes
32523-WOHS S53A	530	12"x12" Floor Tile - Brown with White/Brown Spots	ND	-	No
32523-WOHS S53B			ND	-	No
32523-WOHS S53C			ND	-	No
32523-WOHS S54A	823	2' x 4' Ceiling Tile - Textured Pinhole	ND	-	No
32523-WOHS S54B			ND	-	No
32523-WOHS S54C			ND	-	No
32523-WOHS S55A	526	9"x9" Floor Tile - Red/Brown with White/Brown Streaks	1.4	Chrysotile	Yes
32523-WOHS S55B			NA	Chrysotile	Yes
32523-WOHS S55C			NA	Chrysotile	Yes
32523-WOHS S56A	524	9"x9" Floor Tile - Olive/Green/Grey with White Streaks	Layer 1: 0.75	Chrysotile	Yes
32523-WOHS S56B			Layer 2: ND	-	No
			Layer 1: NA	Chrysotile	Yes
32523-WOHS S56C		Layer 2: ND	-	No	
32523-WOHS S56A			Layer 1: NA	Chrysotile	Yes
			Layer 2: ND	-	No
32523-WOHS S57A	Girl's Washroom (Near 522)	12"x12" Floor Tile - Beige with Beige Fleck	ND	-	No
32523-WOHS S57B			ND	-	No
32523-WOHS S57C			ND	-	No
32523-WOHS S58A	Custodial (Near 522)	12"x12" Floor Tile - Grey with Grey/White Spots	Layer 1: ND	-	No
32523-WOHS S58B			Layer 1: ND	-	No
32523-WOHS S58C			Layer 2: 1.2	Chrysotile	Yes
32523-WOHS S59A	Hall Near Fan Room	9"x9" Floor Tile - Grey with White/Grey Streaks	Layer 1: ND	-	No
32523-WOHS S59B			1.5	Chrysotile	Yes
32523-WOHS S59C			NA	Chrysotile	Yes
32523-WOHS S60A	Mechanical Room	Plaster - Grey	NA	Chrysotile	Yes
32523-WOHS S60B			ND	-	No
32523-WOHS S60C			ND	-	No
32523-WOHS S61A	Duct Space	Drywall - Joint Compound	1.3	Chrysotile	Yes
32523-WOHS S61B			NA	Chrysotile	Yes
32523-WOHS S61C			NA	Chrysotile	Yes
32523-WOHS S62A	Duct Space	Ceiling Finish - Fire Spray/Texture Coat Old Exterior	ND	-	No
32523-WOHS S62B			ND	-	No
32523-WOHS S62C			ND	-	No
32523-WOHS S63A	Weight Room	Drywall - Joint Compound	ND	-	No
32523-WOHS S63B			ND	-	No
32523-WOHS S63C			ND	-	No
32523-WOHS S64A	Hallways Between Gyms	Plaster - White/Grey	ND	-	No
32523-WOHS S64B			ND	-	No
32523-WOHS S64C			ND	-	No
32523-WOHS S64D	808		ND	-	No
32523-WOHS S64E			ND	-	No
32523-WOHS S65A			ND	-	No
32523-WOHS S65B	Phys-Ed Office	2' x 4' Ceiling Tile - Thick Fissure	ND	-	No
32523-WOHS S65C			ND	-	No
32523-WOHS S66A			ND	-	No
32523-WOHS S66B	808	12"x12" Floor Tile - Black with Grey/White Streaks	ND	-	No
32523-WOHS S66C			ND	-	No
32523-WOHS S67A			ND	-	No
32523-WOHS S67B	808	12"x12" Floor Tile - Grey with Grey/White Streaks	ND	-	No
32523-WOHS S67C			ND	-	No
32523-WOHS S68A			ND	-	No
32523-WOHS S68B	Tuck Shop	9"x9" Floor Tile - Dark Grey with White Streaks	Layer 1: 1.3	Chrysotile	Yes
32523-WOHS S68C			Layer 2: 3.5	Chrysotile	Yes
			Layer 1: NA	Chrysotile	Yes
32523-WOHS S69A			Layer 2: NA	Chrysotile	Yes
			Layer 1: NA	Chrysotile	Yes
			Layer 2: NA	Chrysotile	Yes
32523-WOHS S69B	Boiler Room	Pipe Insulation - Boiler Breechings	5	Amosite	Yes
32523-WOHS S69C			65	Chrysotile	Yes
			NA	Amosite	Yes
32523-WOHS S70A	Boiler Room	Pipe Insulation - Mag Block	NA	Chrysotile	Yes
32523-WOHS S70B			NA	Amosite	Yes
32523-WOHS S70C			NA	Amosite	Yes

Table 3 - Sample Summary Table - Waterloo Oxford District Secondary School

**TABLE 3: BULK ASBESTOS SAMPLING SUMMARY**

Sample #	WRDSB Fixed Reference Number	Material Description	Asbestos Content (%)	Fibre Type	Is Material ACM	
32523-WOHS S71A	801	Insulation - Fire Spray Beams and Columns	3.8	Chrysotile	Yes	
32523-WOHS S71B			NA	Chrysotile	Yes	
32523-WOHS S71C			NA	Chrysotile	Yes	
32523-WOHS S72A	801	Plaster - White/Grey	ND	-	No	
32523-WOHS S72B			ND	-	No	
32523-WOHS S72C			ND	-	No	
32523-WOHS S72D	125	Plaster - White/Grey	ND	-	No	
32523-WOHS S72E			ND	-	No	
32523-WOHS S73A			ND	-	No	
32523-WOHS S73B	CU Lunch Room	Drywall - Joint Compound	ND	-	No	
32523-WOHS S73C			ND	-	No	
32523-WOHS S74A	Men's Washroom	Vinyl Sheet Flooring - Beige with Pebble	10	Chrysotile	Yes	
32523-WOHS S74B			NA	Chrysotile	Yes	
32523-WOHS S74C			NA	Chrysotile	Yes	
32523-WOHS S75A	127	9"x9" Floor Tile - Beige with Brown/White Fleck	1.5	Chrysotile	Yes	
32523-WOHS S75B			NA	Chrysotile	Yes	
32523-WOHS S75C			NA	Chrysotile	Yes	
32523-WOHS S76A	125	9"x9" Floor Tile - Green with Faded Streak	1.4	Chrysotile	Yes	
32523-WOHS S76B			NA	Chrysotile	Yes	
32523-WOHS S76C			NA	Chrysotile	Yes	
32523-WOHS S77A	208	1' x 1' Ceiling Tile - Large and Small Pinhole	ND	-	No	
32523-WOHS S77B	206		ND	-	No	
32523-WOHS S78A	208		2' x 4' Ceiling Tile - Short Fissure Random Pinhole	ND	-	No
32523-WOHS S78B	206	ND		-	No	
32523-WOHS S79A	208	Insulation - Paper Backing	ND	-	No	
32523-WOHS S79B			ND	-	No	
32523-WOHS S79C			ND	-	No	
32523-WOHS S80A	208	12"x12" Floor Tile - Green	ND	-	No	
32523-WOHS S80B			ND	-	No	
32523-WOHS S80C			ND	-	No	
32523-WOHS S81A	208	Drywall - Joint Compound	ND	-	No	
32523-WOHS S81B	Work Room (Between 202 and 204)		ND	-	No	
32523-WOHS S81C	207	Drywall - Joint Compound	1.0	Chrysotile	Yes	
32523-WOHS S81D	205		NA	Chrysotile	Yes	
32523-WOHS S81E	NA		Chrysotile	Yes		
32523-WOHS S81F	802	Drywall - Joint Compound	NA	-	No	
32523-WOHS S81G	Library		NA	-	No	
32523-WOHS S82A	206	Plaster - White/Grey	Layer 1: NA Layer 2: NA	-	No	
32523-WOHS S82B	204		Layer 1: NA Layer 2: NA	-	No	
32523-WOHS S82C	207A		Layer 1: NA Layer 2: NA	-	No	
32523-WOHS S82D	207		Layer 1: NA Layer 2: NA	-	No	
32523-WOHS S82E	207A		Layer 1: NA Layer 2: NA	-	No	
32523-WOHS S82F	802		Layer 1: NA Layer 2: NA	-	No	
32523-WOHS S82G	302/303		Layer 1: NA Layer 2: NA	-	No	
32523-WOHS S83A	202		1' x 1' Ceiling Tile - Wide Fissure Random Pinhole	ND	-	No
32523-WOHS S83B				ND	-	No
32523-WOHS S84A	202		12"x12" Floor Tile - Taupe	2.2	Chrysotile	Yes
32523-WOHS S84B		NA		Chrysotile	Yes	
32523-WOHS S84C		NA		Chrysotile	Yes	
32523-WOHS S85A	Work Room (Between 204 and 204)	2' x 4' Ceiling Tile - Long Fissure Random Pinhole	ND	-	No	
32523-WOHS S85B			ND	-	No	
32523-WOHS S85C			ND	-	No	
32523-WOHS S86A	Science Office (Between 204 and 204)	2' x 4' Ceiling Tile - Random Fissure Random Pinhole	ND	-	No	
32523-WOHS S86B			ND	-	No	
32523-WOHS S86C			ND	-	No	
32523-WOHS S87A	207	1' x 1' Ceiling Tile - Crater with Dots	ND	-	No	
32523-WOHS S87B			ND	-	No	
32523-WOHS S87C			ND	-	No	

Table 3 - Sample Summary Table - Waterloo Oxford District Secondary School

TABLE 3: BULK ASBESTOS SAMPLING SUMMARY					
Sample #	WRDSB Fixed Reference Number	Material Description	Asbestos Content (%)	Fibre Type	Is Material ACM
32523-WOHS S88A	207	12"x12" Floor Tile - Grey/Green	Layer 1: 2.7	Chrysotile	Yes
32523-WOHS S88B			Layer 1: NA	Chrysotile	Yes
32523-WOHS S88C			Layer 2: 0.75%	Chrysotile	Yes
32523-WOHS S89A	201	9x9 Vinyl Floor Tile - Grey with Black	Layer 1: NA	Chrysotile	Yes
32523-WOHS S89B			Layer 2: NA	Chrysotile	Yes
32523-WOHS S89C			2.4	Chrysotile	Yes
32523-WOHS S90A	Staff Room	12x12 Vinyl Floor Tile - Grey Oatmeal	NA	Chrysotile	Yes
32523-WOHS S90B			NA	Chrysotile	Yes
32523-WOHS S90C			ND	-	No
32523-WOHS S91A	Health Hallway	12x12 Vinyl Floor Tile - Grey with Spots	ND	-	No
32523-WOHS S91B			ND	-	No
32523-WOHS S91C			ND	-	No
32523-WOHS S92A	Library Hallway	2x2 Ceiling Tile - Short Fissure Random Pinhole	ND	-	No
32523-WOHS S92B			ND	-	No
32523-WOHS S92C			ND	-	No
32523-WOHS S93A	302	2x2 Ceiling Tile - Meal Worm	ND	-	No
32523-WOHS S93B			ND	-	No
32523-WOHS S93C			ND	-	No
32523-WOHS S94A	302	12x12 Vinyl Floor Tile - Cream with Brown	ND	-	No
32523-WOHS S94B			ND	-	No
32523-WOHS S94C			ND	-	No
32523-WOHS S95A	PED	12x12 Vinyl Floor Tile - Brown Oatmeal	Layer 1: 0.75	Chrysotile	Yes
32523-WOHS S95B			Layer 2: ND	-	No
32523-WOHS S95C			Layer 1: NA	Chrysotile	Yes
32523-WOHS S96A	Conference Room	9x9 Vinyl Floor Tile - Taupe with Spots	Layer 2: ND	-	No
32523-WOHS S96B			Layer 1: NA	Chrysotile	Yes
32523-WOHS S96C			Layer 2: ND	-	No
32523-WOHS S97A	Exterior	Ceiling Finish - Exterior Texture Coat	Layer 1: NA	Chrysotile	Yes
32523-WOHS S97B			Layer 2: ND	-	No
32523-WOHS S97C			ND	-	No
32523-WOHS S98A	-	Ceiling Finish - Texture Coat	ND	-	No
32523-WOHS S98B			ND	-	No
32523-WOHS S98C			ND	-	No
<b>Additional Sampling (August 2010)</b>					
34152-200-S01A	Corridor (Stairwell 902)	Drywall Skim Coat	ND	-	No
34152-200-S01B			ND	-	No
34152-200-S01C			ND	-	No
34152-200-S02A	Adjacent to Teacher Common Room	Firespray Overspray - On Ducts	1	Actinolite	Yes
34152-200-S02B			15	Chrysotile	Yes
34152-200-S02C			NA	Actinolite	Yes
34152-200-S03A	Corridor Adjacent to Room 502	Drywall Glue/Puddy	NA	Chrysotile	Yes
34152-200-S03B			ND	-	No
34152-200-S03C			ND	-	No
34152-200-S04A	Boiler Room	Plaster	ND	-	No
34152-200-S04B			ND	-	No
34152-200-S04C			ND	-	No
34152-200-S05A	Exterior (Stairwell 909)	Caulking - Grey	ND	-	No
34152-200-S05B			ND	-	No
34152-200-S05C			ND	-	No
34152-200-S06A	Exterior (Stairwell 909)	Caulking - White	ND	-	No
34152-200-S06B			ND	-	No
34152-200-S06C			ND	-	No
<b>Additional Sampling (November 2010)</b>					
34152-200-S01A	-	Vermiculite - Insulation	ND	-	No
34152-200-S01B	-		ND	-	No
34152-200-S01C	-		ND	-	No
34152-200-S01A-C	-	Vermiculite	Chatfield Analysis - ND	-	No

Table 3 - Sample Summary Table - Waterloo Oxford District Secondary School

TABLE 3: BULK ASBESTOS SAMPLING SUMMARY					
Sample #	WRDSB Fixed Reference Number	Material Description	Asbestos Content (%)	Fibre Type	Is Material ACM
<b>2011 Asbestos Audit Update</b>					
BR-LC-Plaster-S01a	Boiler Room	Lower Ceiling Plaster	ND	-	No
BR-LC-Plaster-S01b			ND	-	No
BR-LC-Plaster-S01c			ND	-	No
BR-UC-Plaster-S02a	Boiler Room	Upper Ceiling Plaster	ND	-	No
BR-UC-Plaster-S02b			ND	-	No
BR-UC-Plaster-S02c			ND	-	No
<b>Additional Sampling (2013)</b>					
WODSS -S01A	Collected by WRDSB	2'x2' Ceiling Tile	ND	-	No
WODSS -S01B			ND	-	No
WODSS -S01C			ND	-	No
<b>Additional Sampling (July 11, 2016)</b>					
S01A	-	Texture Coat on Canopy	ND	-	No
S01B	-	Texture Coat on Canopy	ND	-	No
S01C	-	Texture Coat on Canopy	ND	-	No
<b>Additional Sampling (November 3, 2017)</b>					
S01A	535	1'x1' Medium Pinhole Ceiling Tiles	ND	-	No
S01B	535	1'x1' Medium Pinhole Ceiling Tiles	ND	-	No
S01C	535	1'x1' Medium Pinhole Ceiling Tiles	ND	-	No
<b>Additional Sampling (April 9, 2018)</b>					
S01A	811	Ceiling Tiles - Random Fissure Pattern	ND	-	No
S01B	811	Ceiling Tiles - Random Fissure Pattern	ND	-	No
S01C	811	Ceiling Tiles - Random Fissure Pattern	ND	-	No
S02A	811	Ceiling Tiles - Small Fissure Pattern	ND	-	No
S02B	811	Ceiling Tiles - Small Fissure Pattern	ND	-	No
S02C	811	Ceiling Tiles - Small Fissure Pattern	ND	-	No
<b>2018 Asbestos Audit Update</b>					
S01A	403B	2'x4' Small Fissure Small Pinhole Ceiling Tile	ND	-	No
S01B	403B	2'x4' Small Fissure Small Pinhole Ceiling Tile	ND	-	No
S01C	403B	2'x4' Small Fissure Small Pinhole Ceiling Tile	ND	-	No
S02A	513A	2'x4' Medium Fissure Random Pinhole Ceiling Tile	ND	-	No
S02B	513A	2'x4' Medium Fissure Random Pinhole Ceiling Tile	ND	-	No
S02C	513A	2'x4' Medium Fissure Random Pinhole Ceiling Tile	ND	-	No
S03A	512B	Plaster - 1962 Addition	ND	-	No
S03B	510	Plaster - 1962 Addition	ND	-	No
S03C	510	Plaster - 1962 Addition	ND	-	No
S04A	512C	1'x1' B/S PH Ceiling Tile - Brown Mastic	ND	-	No
S04B	512C	1'x1' B/S PH Ceiling Tile - Brown Mastic	ND	-	No
S04C	512C	1'x1' B/S PH Ceiling Tile - Brown Mastic	ND	-	No
<b>S05A</b>	<b>809</b>	<b>2'x2' Dense Fissure Random Pinhole Ceiling Tile</b>	<b>5</b>	<b>Amosite</b>	<b>Yes</b>
<b>S05B</b>	<b>809</b>	<b>2'x2' Dense Fissure Random Pinhole Ceiling Tile</b>	<b>NA</b>	<b>Amosite</b>	<b>Yes</b>
<b>S05C</b>	<b>809</b>	<b>2'x2' Dense Fissure Random Pinhole Ceiling Tile</b>	<b>NA</b>	<b>Amosite</b>	<b>Yes</b>
S06A	809	2'x2' Medium Fissure Pinhole Ceiling Tile	ND	-	No
S06B	809	2'x2' Medium Fissure Pinhole Ceiling Tile	ND	-	No
S06C	809	2'x2' Medium Fissure Pinhole Ceiling Tile	ND	-	No
S07A	305	12"x12" Teal Dense Fleck Floor Tile	ND	-	No
S07B	305	12"x12" Teal Dense Fleck Floor Tile	ND	-	No
S07C	305	12"x12" Teal Dense Fleck Floor Tile	ND	-	No
S08A	207A	1'x1' Texture Fissure Pinhole Ceiling Tile	ND	-	No
S08B	207A	1'x1' Texture Fissure Pinhole Ceiling Tile	ND	-	No
S08C	207A	1'x1' Texture Fissure Pinhole Ceiling Tile	ND	-	No
<b>S09A</b>	<b>104</b>	<b>9"x9" Olive with White Streak Floor Tile</b>	<b>2</b>	<b>Chrysotile</b>	<b>Yes</b>
<b>S09B</b>	<b>104</b>	<b>9"x9" Olive with White Streak Floor Tile</b>	<b>NA</b>	<b>Chrysotile</b>	<b>Yes</b>
<b>S09C</b>	<b>104</b>	<b>9"x9" Olive with White Streak Floor Tile</b>	<b>NA</b>	<b>Chrysotile</b>	<b>Yes</b>
S10A	400B	2'x4' Texture Pinhole Ceiling Tile	ND	-	No
S10B	400B	2'x4' Texture Pinhole Ceiling Tile	ND	-	No
S10C	400B	2'x4' Texture Pinhole Ceiling Tile	ND	-	No
<b>S11A</b>	<b>122</b>	<b>9"x9" Olive w Black Streak Vinyl Floor Tiles</b>	<b>1</b>	<b>Chrysotile</b>	<b>Yes</b>
<b>S11B</b>	<b>122</b>	<b>9"x9" Olive w Black Streak Vinyl Floor Tiles</b>	<b>NA</b>	<b>Chrysotile</b>	<b>Yes</b>
<b>S11C</b>	<b>122</b>	<b>9"x9" Olive w Black Streak Vinyl Floor Tiles</b>	<b>NA</b>	<b>Chrysotile</b>	<b>Yes</b>
S12A	522	1'x1' Large/Medium Pinhole Cellulose Ceiling Tile Brown Mastic	ND	-	No
S12B	522	1'x1' Large/Medium Pinhole Cellulose Ceiling Tile Brown Mastic	ND	-	No

Table 3 - Sample Summary Table - Waterloo Oxford District Secondary School

**TABLE 3: BULK ASBESTOS SAMPLING SUMMARY**

Sample #	WRDSB Fixed Reference Number	Material Description	Asbestos Content (%)	Fibre Type	Is Material ACM
S12C	522	1'x1' Large/Medium Pinhole Cellulose Ceiling Tile Brown Mastic	ND	-	No
S13A	530	1'x1' Large/Medium Pinhole Ceiling Tile	ND	-	No
S13B	530	1'x1' Large/Medium Pinhole Ceiling Tile	ND	-	No
S13C	530	1'x1' Large/Medium Pinhole Ceiling Tile	ND	-	No
<b>2018 Asbestos Audit Update, Additional Sampling (October 5, 2018)</b>					
S01A	518	Beige Sealant on Interior Doors (1972)	ND	-	No
S01B	518	Beige Sealant on Interior Doors (1972)	ND	-	No
S01C	518	Beige Sealant on Interior Doors (1972)	ND	-	No
S02A	518	Brown Sealant on Exterior Doors (1972)	8	Chrysotile	Yes
S02B	518	Brown Sealant on Exterior Doors (1972)	NA	Chrysotile	Yes
S02C	518	Brown Sealant on Exterior Doors (1972)	NA	Chrysotile	Yes
S03A	517	Beige Sealant on Interior Window Frames (1972)	8	Chrysotile	Yes
S03B	517	Beige Sealant on Interior Window Frames (1972)	NA	Chrysotile	Yes
S03C	517	Beige Sealant on Interior Window Frames (1972)	NA	Chrysotile	Yes
S04A	824	Beige Sealant on Interior Window Frames (1962)	1	Chrysotile	Yes
S04B	824	Beige Sealant on Interior Window Frames (1962)	NA	Chrysotile	Yes
S04C	824	Beige Sealant on Interior Window Frames (1962)	NA	Chrysotile	Yes
S05A	1009	Beige Sealant on Interior Window Frames (1966)	5	Chrysotile	Yes
S05B	1009	Beige Sealant on Interior Window Frames (1966)	NA	Chrysotile	Yes
S05C	1009	Beige Sealant on Interior Window Frames (1966)	NA	Chrysotile	Yes
<b>2022 Additional Sampling (October 3, 2022)</b>					
S01A	102A	Trowel Applied Fireproofing	40	Chrysotile	Yes
S01B	102A	Trowel Applied Fireproofing	NA	Chrysotile	Yes
S01C	102A	Trowel Applied Fireproofing	NA	Chrysotile	Yes

NA: Not Analyzed due to stop positive method ND: No asbestos fibres detected above the laboratory minimum detection limit

A bulk material sample containing 0.5% or more asbestos therefore establishes that material as asbestos-containing. In accordance with Table 1 of O. Reg. 278/05, a minimum number of samples for the material to be classified as non asbestos. A homogeneous material is defined by O. Reg. 278/05 "as material that is uniform in colour and texture". Homogeneous samples are identified by an alphabetical suffix to sample names to represent multiple samples of a homogeneous material. When a homogeneous material is analysed it is determined to be asbestos-containing upon the first positive detection of asbestos equal to or greater than 0.5%. Subsequent samples of the same material are therefore not analysed. Some bulk samples are comprised of multiple layers and as such will require multiple analysis. In such cases each layer is isolated at the laboratory and analysed individually to determine asbestos content. As a result the laboratory may report additional samples beyond the submitted number of samples or include multiple analyses as subsets within a sample.

## Certificate of Analysis

**MTE Consultants Inc. (Kitchener)**

520 Bingemans Centre Dr.  
Kitchener, ON N2B 3X9  
Attn: Paul Semeniuk

Client PO: 34532-940

Project: 34532-940 WO-100 Series 2nd Mech  
Custody:

Report Date: 13-Oct-2022

Order Date: 6-Oct-2022

**Order #: 2241396**

This Certificate of Analysis contains analytical data applicable to the following samples as submitted:

Parcel ID	Client ID
2241396-01	S01A - Trowel Applied Fire Proofing - Rm 120A
2241396-02	S01B - Trowel Applied Fire Proofing - Rm 120A
2241396-03	S01C - Trowel Applied Fire Proofing - Rm 120A

Approved By:



Emma Diaz

Senior Analyst

Any use of these results implies your agreement that our total liability in connection with this work, however arising, shall be limited to the amount paid by you for this work, and that our employees or agents shall not under any circumstances be liable to you in connection with this work.

Certificate of Analysis  
 Client: MTE Consultants Inc. (Kitchener)  
 Client PO: 34532-940

Report Date: 13-Oct-2022  
 Order Date: 6-Oct-2022

Project Description: 34532-940 WO-100 Series 2nd Mech

**Asbestos, PLM Visual Estimation    \*\*MDL - 0.5%\*\***

Parcel ID	Sample Date	Colour	Description	Asbestos Detected	Material Identification	% Content
2241396-01	03-Oct-22	Grey	Fireproofing	Yes	<b>Client ID: S01A - Trowel Applied Fire Proofing - Rm 120A</b> Chrysotile Non-Fibers	[Z-01] 40 60
2241396-02	03-Oct-22	Grey	Fireproofing		<b>Client ID: S01B - Trowel Applied Fire Proofing - Rm 120A</b> not analyzed, positive stop	[Z-01]
2241396-03	03-Oct-22	Grey	Fireproofing		<b>Client ID: S01C - Trowel Applied Fire Proofing - Rm 120A</b> not analyzed, positive stop	[Z-01]

\*\* Analytes in bold indicate asbestos mineral content.

**Analysis Summary Table**

Analysis	Method Reference/Description	Lab Location	Lab Accreditation	Analysis Date
Asbestos, PLM Visual Estimation	AppE to SubE of 40CFR Part753 and EPA/600/R-93/116	1 - Mississauga	CALA 3762	12-Oct-22

Mississauga Lab: 15 - 6800 Kitimat Rd Mississauga, Ontario, L5N 5M1

**Qualifier Notes**

Sample Qualifiers :

Z-01: Sample contains vermiculite.

**Work Order Revisions | Comments**

None

## Supportive Documentation

For Tender Purposes



September 24, 2012  
MTE File No.: 34152-500

Ms. Daniela Budure  
Environmental Officer  
Waterloo Region District School Board  
51 Ardelt Avenue  
Kitchener, ON N2C 2R5

Dear Ms. Budure:

**Re: Results of Total Airborne Fibre Sampling at  
Waterloo-Oxford District Secondary School,  
1206 Snyders Road West, Cambridge, Ontario**

MTE Consultants Inc. (MTE) was retained by the Waterloo Region District School Board (WRDSB) to complete a sampling event as part of an ongoing program to assess airborne asbestos fibre concentrations in conjunction with ongoing asbestos management at Waterloo-Oxford District Secondary School (WODSS) located at 1206 Snyders Road West in Cambridge, Ontario.

## **BACKGROUND**

The WRDSB, along with MTE, developed a strategy to manage and monitor the existing spray fireproofing within WODSS.

In September 2012, inspection services, documentation, and air monitoring programs were developed and conducted by MTE. A portion of the above mentioned monitoring program included ongoing sampling for total airborne fibre analysis by Phase Contrast Microscopy (PCM) to assess any potential risk of building occupant exposure to airborne asbestos fibres. Air sampling will continue as part of the ongoing monitoring program, and sampling will be conducted on a bi-annual basis, as requested by the WRDSB.

## **SCOPE OF WORK**

The scope of MTE's services for this assignment was:

- Collection of three (3) air samples from selected corridors on the First floor and preparation of one (1) blank sample for fibre analysis;
- Submission of samples to an accredited laboratory for analysis of total airborne fibre by PCM;

- Interpretation of analytical results with respect to occupational worker exposure; and
- Preparation of a letter report of findings with appropriate recommendations, if required.

## METHODOLOGY

In conjunction with the ongoing management program, air samples were collected by MTE from selected corridors on September 12, 2012. A total of three (3) air samples were collected and one (1) blank sample was prepared for quality control purposes. Samples were collected in accordance with The National Institute for Occupational Safety and Health (NIOSH) Method 7400 and were submitted to EMSL Canada Inc. in Mississauga, Ontario. Table 1 provides a summary of sample locations and laboratory analytical results.

EMSL is accredited through the National Voluntary Laboratory Accreditation Program (NVLAP) for airborne analysis by PCM. Laboratory certificates of analysis are provided as an attachment to this report. The sampling event was conducted after normal class hours. In order to obtain samples representative of typical conditions within the building during occupancy, the day-time operational settings of the buildings heating and ventilation system were maintained throughout the sampling event. The sampling event also started immediately following class dismissal to obtain the most accurate representation of classroom activity.

**TABLE 1: SUMMARY OF AIRBORNE FIBRE CONCENTRATIONS AT SELECTED SAMPLE LOCATIONS THROUGHOUT WODSS ON SEPTEMBER 12, 2012 AS DETERMINED BY PHASE CONTRAST MICROSCOPY**

Sample Name	Sample Location	Sample Air Volume Collected (L)	Analytical Results: Fibres per cubic centimetre of Air (f/cc)
CC419777	1 <sup>st</sup> Floor – Corridor 7	1800	0.002
CC419808	1 <sup>st</sup> Floor – Corridor 4	1800	<0.001
CC419788	1 <sup>st</sup> Floor – Corridor 1	1800	<0.001
CC419795	Blank	Not Applicable	Non-detect*

\*No detections of fibres based on the laboratory detection limit reported for blank sample.

## DISCUSSION

### Airborne Fibres

One of the three air samples collected within the selected corridor sample locations reported concentrations of total airborne fibres to be above the laboratory method detection limit of 0.001 fibres per cubic centimetre of air (f/cc).

It should be noted that the analysis method does not distinguish between asbestos fibres and other fibre sources. Sample method detection limits have been rounded to the nearest significant digit. Ontario Regulation 490/09 Designated Substances prescribes an acceptable Time Weighted Average Exposure Value (TWAEV) to asbestos fibre of not more than 0.1 fibres per cubic centimetre of air (f/cc). Standard industrial hygiene practice considers a concentration greater than one half the TWAEV (0.05 f/cc) as actionable in order to control exposure and ensure worker safety. Ontario Regulation 278/05 Designated Substance – Asbestos on Construction Projects and in Buildings and Repair Operations prescribes an acceptable post asbestos removal air clearance concentration of not more than 0.01 f/cc or one tenth the TWAEV. This concentration is deemed protective of human health for workers and occupants of the building. All samples reported concentrations of total airborne fibres to be less than the clearance criteria of 0.01 f/cc. The reported concentrations do not suggest an overexposure to airborne asbestos for workers or building occupants.

## CONCLUSIONS AND RECOMMENDATIONS

Based on analytical results the following conclusions are presented:

- Total airborne fibre concentrations within the sampled corridors are well below the Ontario Ministry of Labour TWAEV acceptable abatement and clearance criteria prescribed in Ontario Regulation 490/09 and 278/05 respectively;
- The reported concentrations in the air samples do not indicate workers or building occupants are at any elevated risk of over exposure to airborne asbestos fibres, under current site conditions;
- These findings should be incorporated into the building asbestos audit and Asbestos Management Program; and
- If work is required which will disturb or is likely to disturb asbestos-containing material, the work must be conducted in accordance with Ontario Regulation 278/05 by trained and certified asbestos removal contractors.

## LIMITATIONS

Services performed by **MTE Consultants Inc.** (MTE) were conducted in a manner consistent with the level of care and skill ordinarily exercised by members of the Environmental Engineering & Consulting profession. No other representation expressed or implied as to the accuracy of the information, conclusions or recommendations is included or intended in this report.

This report was completed for the sole use of MTE and Waterloo Region District School Board. It was completed in accordance with the Scope of Work. As such, this report may not deal with all issues potentially applicable to the site and may omit issues, which are or may be of interest to the reader. MTE makes no representation that the present report has dealt with all-important environmental features, except as provided in the Scope of Work. All findings and conclusions presented in this report are based on site conditions, as they existed during the time period of the investigation. This report is not intended to be exhaustive in scope or to imply a risk-free facility.

Some areas could not be investigated due to non-destructive, non-invasive, inspection restrictions or prohibited access. Although the presence of asbestos-containing materials (ACM) has been anticipated in these areas where reasonable, the accuracy of such information must be confirmed before any potential disturbance of materials which may contain asbestos. It is also possible that ACM may be visually or physically concealed by but not necessarily limited to ceilings, walls, bulkheads, floors, roof systems or other similar features or structures.

Any use which a third party makes of this report, or any reliance on, or decisions to be made based upon it, are the responsibility of such third parties. MTE accepts no responsibility for liabilities incurred by or damages, if any, suffered by any third party as a result of decisions made or actions taken, based upon this report. Others with interest in the site should undertake their own investigations and studies to determine how or if the condition affects them or their plans.

It should be recognized that the passage of time may affect the views, conclusions and recommendations (if any) provided in this report because environmental conditions of a property can change. Should additional or new information become available, MTE recommends that it be brought to our attention in order that we may re-assess the contents of this report.

Sincerely,

### MTE CONSULTANTS INC.



Greg Eller, BA, C.Tech. LEED AP (BD+C)  
Project Manager  
[geller@mte85.com](mailto:geller@mte85.com)



Paul Semeniuk, B.E.S.  
Building Health Sciences Technologist  
[psemeniuk@mte85.com](mailto:psemeniuk@mte85.com)

GSE:ksr  
Attach.



# ATTACHMENTS

For Tender Purposes

**EMSL Canada Inc.**

10 Falconer Drive, Unit #3, Mississauga, ON L5N 3L8

Phone/Fax: 289-997-4602 / (289) 997-4607

<http://www.emsl.com>[torontolab@emsl.com](mailto:torontolab@emsl.com)

EMSL Canada Or 551204186

CustomerID: 55MCFE78

CustomerPO: 34152-500

ProjectID:

Attn: **Paul Semeniuk**  
**MTE Consultants, Inc.**  
**520 Bingemans Centre Drive**

**Kitchener, ON N2B 3X9**

Project: 1206 SNYDERS ROAD WEST-34152-500

Phone: (519) 743-6500  
 Fax: (519) 743-6513  
 Received: 09/14/12 11:06 AM  
 Analysis Date: 9/21/2012  
 Collected: 9/12/2012

**Test Report: Fiber Count by Phase Contrast Microscopy (PCM), NIOSH 7400 Method,  
 Revision 3, Issue 2, 8/15/94**

Sample	Location	Sample Date	Volume (liters)	Fibers	Fields	LOD (fib/cc)	Fibers/mm <sup>2</sup>	Fibers/cc	Notes
CC419777 551204186-0001	CORRIDOR 7	9/12/2012	1800.00	7.5	100	0.001	9.55	0.002	
CC419808 551204186-0002	CORRIDOR 4	9/12/2012	1800.00	<5.5	100	0.001	<7.0	<0.001	
CC419788 551204186-0003	CORRIDOR 1	9/12/2012	1800.00	<5.5	100	0.001	<7.0	<0.001	
CC419795 551204186-0004	BLANK			<5.5	100		<7.0		Field Blank

The results reported have been blank corrected as applicable.

Analyst(s)

Kevin Pang (4)

Kevin Pang  
or other approved signatory

Limit of detection is 7 fibers/mm<sup>2</sup>. Intra-laboratory Sr values: 5-20 fibers = 0.32, 21-50 fibers = 0.24, 51-100 fibers = 0.17. Inter-laboratory Sr values (Average of EMSL round robin data) = 0.29. The laboratory is not responsible for data reported in fibers/cc, which is dependent on volume collected by non-laboratory personnel. Results have been blank corrected as applicable. EMSL maintains liability limited to cost of analysis. This report relates only to the samples reported above and may not be reproduced, except in full, without written approval by EMSL. EMSL bears not responsibility for sample collection activities or analytical method limitations. Interpretation and use of test results are the responsibility of the client. Samples received in good condition unless otherwise noted.

Samples analyzed by EMSL Canada Inc. Mississauga, ON

Initial report from 09/21/2012 09:15:39



April 10, 2013  
MTE File No.: 34152-500

Ms. Daniela Budure  
Environmental Officer  
Waterloo Region District School Board  
51 Ardelt Avenue  
Kitchener, ON N2C 2R5

Dear Ms. Budure:

**Re: Results of Total Airborne Fibre Sampling at  
Waterloo-Oxford District Secondary School,  
1206 Snyders Road West, Cambridge, Ontario**

MTE Consultants Inc. (MTE) was retained by the Waterloo Region District School Board (WRDSB) to complete a sampling event as part of an ongoing program to assess airborne asbestos fibre concentrations in conjunction with ongoing asbestos management at Waterloo-Oxford District Secondary School (W-ODSS) located at 1206 Snyders Road West in Cambridge, Ontario.

## **BACKGROUND**

The WRDSB, along with MTE, developed a strategy to manage and monitor the existing spray fireproofing within W-ODSS.

In September 2012, inspection services, documentation, and air monitoring programs were developed and conducted by MTE. A portion of the above-mentioned monitoring program included ongoing sampling for total airborne fibre analysis by Phase Contrast Microscopy (PCM) to assess any potential risk to building occupants with regards to exposure to airborne asbestos fibres. Air sampling will continue as part of the ongoing monitoring program, and sampling will be conducted on a bi-annual basis, as requested by the WRDSB.

As part of the ongoing monitoring program air sampling was conducted between September, 2012 and March 2013. Analytical results from the previous sampling events are documented in MTE's previous reports and are listed in an attachment to this report.

This report should be read in conjunction with previous reports related to airborne fibre sampling at the school.

Sampling is conducted on a bi-annual basis, as requested by the WRDSB.

## SCOPE OF WORK

The scope of MTE's services for this assignment was:

- Collection of three (3) air samples from selected corridors on the first and second floors;
- Analysis of total airborne fibre by Phase Contrast Microscopy following the National Institute of Occupational Safety and Health US (NIOSH) Method 7400;
- Interpretation of analytical results with respect to occupational worker exposure; and
- Preparation of a letter report of findings with appropriate recommendations, if required.

## METHODOLOGY

In conjunction with the ongoing management program, air samples were collected by MTE from selected classrooms on March 14, 2013. A total of three (3) air samples were collected. Samples were collected in accordance with The National Institute for Occupational Safety and Health (NIOSH) Method 7400 and were analyzed by MTE. MTE participates and maintains proficient standing in the Canadian Association for Laboratory Accreditation (CALA) proficiency testing in asbestos and other fibres in air by Phase Contrast Microscopy Analysis under Membership number 3827. Table 1 provides a summary of sample locations and laboratory analytical results.

**TABLE 1: SUMMARY OF AIRBORNE FIBRE CONCENTRATIONS AT SELECTED SAMPLE LOCATIONS THROUGHOUT WODSS ON MARCH 14, 2013 AS DETERMINED BY PHASE CONTRAST MICROSCOPY**

Sample Name	Sample Location	Sample Air Volume Collected (L)	Analytical Results: Fibres per cubic centimetre of Air (f/cc)
BW828436	1 <sup>st</sup> Floor – Transportation Technology 510	1800	<0.011
BW828198	1 <sup>st</sup> Floor – Department Head Offices 101	1800	<0.011
BW828452	2 <sup>nd</sup> Floor – Classroom 527	1800	<0.011

## **DISCUSSION**

### **Airborne Fibres**

All three air samples collected within the selected corridor sample locations reported concentrations of total airborne fibres to be below the reporting limit of 0.011 fibres per cubic centimetre of air (f/cc).

It should be noted that the analysis method does not distinguish between asbestos fibres and other fibre sources. Sample method detection limits have been rounded to the nearest significant digit. Ontario Regulation 490/09 Designated Substances prescribes an acceptable Time Weighted Average Exposure Value (TWAEV) to asbestos fibre of not more than 0.1 fibres per cubic centimetre of air (f/cc). Standard industrial hygiene practice considers a concentration greater than one half the TWAEV (0.05 f/cc) as actionable in order to control exposure and ensure worker safety. Ontario Regulation 278/05 Designated Substance – Asbestos on Construction Projects and in Buildings and Repair Operations prescribes an acceptable post asbestos removal air clearance concentration of not more than 0.01 f/cc or one tenth the TWAEV. This concentration is deemed protective of human health for workers and occupants of the building. All samples reported concentrations of total airborne fibres to be less than the clearance criteria of 0.01 f/cc. The reported concentrations do not suggest an overexposure to airborne asbestos for workers or building occupants.

## **CONCLUSIONS AND RECOMMENDATIONS**

Based on analytical results the following conclusions are presented:

- Total airborne fibre concentrations within the sampled corridors are well below the Ontario Ministry of Labour TWAEV acceptable abatement and clearance criteria prescribed in Ontario Regulation 490/09 and 278/05 respectively;
- The reported concentrations in the air samples do not indicate workers or building occupants are at any elevated risk of over exposure to airborne asbestos fibres, under current site conditions;
- These findings should be incorporated into the building asbestos audit and Asbestos Management Program; and
- If work is required which will disturb or is likely to disturb asbestos-containing material, the work must be conducted in accordance with Ontario Regulation 278/05 by trained and certified asbestos removal contractors.

## LIMITATIONS

Services performed by **MTE Consultants Inc.** (MTE) were conducted in a manner consistent with the level of care and skill ordinarily exercised by members of the Environmental Engineering & Consulting profession. No other representation expressed or implied as to the accuracy of the information, conclusions or recommendations is included or intended in this report.

This report was completed for the sole use of MTE and Waterloo Region District School Board. It was completed in accordance with the Scope of Work. As such, this report may not deal with all issues potentially applicable to the site and may omit issues, which are or may be of interest to the reader. MTE makes no representation that the present report has dealt with all-important environmental features, except as provided in the Scope of Work. All findings and conclusions presented in this report are based on site conditions, as they existed during the time period of the investigation. This report is not intended to be exhaustive in scope or to imply a risk-free facility.

Some areas could not be investigated due to non-destructive, non-invasive, inspection restrictions or prohibited access. Although the presence of asbestos-containing materials (ACM) has been anticipated in these areas where reasonable, the accuracy of such information must be confirmed before any potential disturbance of materials which may contain asbestos. It is also possible that ACM may be visually or physically concealed by but not necessarily limited to ceilings, walls, bulkheads, floors, roof systems or other similar features or structures.

Any use which a third party makes of this report, or any reliance on, or decisions to be made based upon it, are the responsibility of such third parties. MTE accepts no responsibility for liabilities incurred by or damages, if any, suffered by any third party as a result of decisions made or actions taken, based upon this report. Others with interest in the site should undertake their own investigations and studies to determine how or if the condition affects them or their plans.

It should be recognized that the passage of time may affect the views, conclusions and recommendations (if any) provided in this report because environmental conditions of a property can change. Should additional or new information become available, MTE recommends that it be brought to our attention in order that we may re-assess the contents of this report.

Sincerely,

### MTE CONSULTANTS INC.

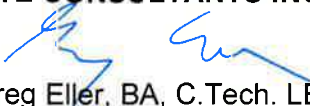

Greg Eiler, BA, C.Tech. LEED AP (BD+C)  
Project Manager  
[geller@mte85.com](mailto:geller@mte85.com)



Paul Semeniuk, B.E.S.  
Building Health Sciences Technologist  
[psemeniuk@mte85.com](mailto:psemeniuk@mte85.com)

GSE:plw

Attach:

M:\34152\500\PDFs\March 2013\34152-500 - Air Sampling Report - Waterloo-Oxford D.S.S. - April-10-13.doc



## ATTACHMENTS

For Tender Purposes

**List of Previous MTE Reports – Waterloo-Oxford District Secondary School – Airborne Fibre Sampling: MTE #: 34152-500**

- *“Results of Total Airborne Fibre Sampling at Waterloo-Oxford District Secondary School, 1206 Snyders Road West, Cambridge, Ontario”, dated September 24, 2012. MTE #: 34152-500.*

For Tender Purposes



# MTE

More Than Engineering

## PHASE CONTRAST MICROSCOPY (PCM) ANALYSIS REPORT

Samples were analyzed using a Zeiss Axio Star Plus or Nikon Eclipse E100 Phase Contrast Microscope in accordance with NIOSH method 7400 "Asbestos and Other Fibres by PCM". The results of this report apply only to the materials tested.

### CLIENT INFORMATION

Client Name: **WRDSB**

Project No: **34152-500**

Client Address: 51 Ardelt Avenue, Kitchener, ON N2C 2R5

Site Address: 1206 Snyders Rd W Baden, ON N3A 1A4

### SAMPLING INFORMATION

Sampled by: PXS

Sampling date: Mar-14-13

Analyzed by: MJM

Analysis date: Mar-26-13

Analyst Signature: 

Manager's Signature: 

### SAMPLE INFORMATION

Sample #: 1552

Cassette Barcode Number: BW828436

Sample ID: **WODSS-34152-500-AS1**

Fibres/field: 0.105

Flow Rate (L/min): 15.00

Cassette Size (mm<sup>2</sup>): 385

Duration (min): 120

Field Size: 0.00785

Volume (L): 1800

R.L. ≤ **0.011** (f/cc)

#### Notes:

- R.L. = Reporting Limit based on Quantitation Limit for Sampling Volume based on approximately 40 fibres/100 fields
- (f/cc) = fibres per cubic centimetre of air

MTE Consultants Inc. participates and maintains proficient standing in the Canadian Association for Laboratory Accreditation Inc. (CALA) Asbestos Proficiency Testing for Asbestos and Other Fibres in air by Phase Contrast Microscopy (PCM) analysis under Membership Number 3827.

## PHASE CONTRAST MICROSCOPY (PCM) ANALYSIS REPORT

Samples were analyzed using a Zeiss Axio Star Plus or Nikon Eclipse E100 Phase Contrast Microscope in accordance with NIOSH method 7400 "Asbestos and Other Fibres by PCM". The results of this report apply only to the materials tested.

### CLIENT INFORMATION

Client Name: **WRDSB**

Project No: **34152-500**

Client Address: 51 Ardel Avenue, Kitchener, ON N2C 2R5

Site Address: 1206 Snyders Rd W Baden, ON N3A 1A4

### SAMPLING INFORMATION

Sampled by: PXS

Sampling date: Mar-14-13

Analyzed by: MJM

Analysis date: Mar-26-13

Analyst Signature: 

Manager's Signature: 

### SAMPLE INFORMATION

Sample #: 1553

Cassette Barcode Number: BW828198

Sample ID: **WODSS-34152-500-AS2**

Fibres/field: 0.180

Flow Rate (L/min): 15.00

Cassette Size (mm<sup>2</sup>): 385

Duration (min): 120

Field Size: 0.00785

Volume (L): 1800

R.L. ≤ 0.011 (f/cc)

#### Notes:

- R.L. = Reporting Limit based on Quantitation Limit for Sampling Volume based on approximately 40 fibres/100 fields
- (f/cc) = fibres per cubic centimetre of air

## PHASE CONTRAST MICROSCOPY (PCM) ANALYSIS REPORT

Samples were analyzed using a Zeiss Axio Star Plus or Nikon Eclipse E100 Phase Contrast Microscope in accordance with NIOSH method 7400 "Asbestos and Other Fibres by PCM". The results of this report apply only to the materials tested.

### CLIENT INFORMATION

Client Name: **WRDSB**

Project No: **34152-500**

Client Address: 51 Ardel Avenue, Kitchener, ON N2C 2R5

Site Address: 1206 Snyders Rd W Baden, ON N3A 1A4

### SAMPLING INFORMATION

Sampled by: PXS

Sampling date: Mar-14-13

Analyzed by: MJM

Analysis date: Mar-26-13

Analyst Signature: 

Manager's Signature: 

### SAMPLE INFORMATION

Sample #: 1554

Cassette Barcode Number: BW828452

Sample ID: **WODSS-34152-500-AS3**

Fibres/field: 0.055

Flow Rate (L/min): 15.00

Cassette Size (mm<sup>2</sup>): 385

Duration (min): 120

Field Size: 0.00785

Volume (L): 1800

R.L. ≤ 0.011 (f/cc)

#### Notes:

- R.L. = Reporting Limit based on Quantitation Limit for Sampling Volume based on approximately 40 fibres/100 fields
- (f/cc) = fibres per cubic centimetre of air



September 2, 2016  
MTE File No.: C34152-900

Ms. Daniela Budure  
Environmental Officer  
Waterloo Region District School Board  
51 Ardelt Avenue  
Kitchener, ON N2C 2R5

Dear Ms. Budure:

**Re: Results of Total Airborne Fibre Sampling at  
Waterloo-Oxford District Secondary School,  
1206 Snyders Road West, Cambridge, Ontario**

MTE Consultants Inc. (MTE) was retained by the Waterloo Region District School Board (WRDSB) to complete a sampling event as part of an ongoing program to assess airborne asbestos fibre concentrations in conjunction with ongoing asbestos management at Waterloo-Oxford District Secondary School (WODSS) located at 1206 Snyders Road West in Cambridge, Ontario.

**BACKGROUND**

The WRDSB, along with MTE, developed a strategy to manage and monitor the existing spray fireproofing within WODSS.

In September 2012, inspection services, documentation, and air monitoring programs were developed and conducted by MTE. A portion of the above mentioned monitoring program included ongoing sampling for total airborne fibre analysis by Phase Contrast Microscopy (PCM) to assess any potential risk of building occupant exposure to airborne asbestos fibres. Air sampling will continue as part of the ongoing monitoring program, and sampling will be conducted on a bi-annual basis, as requested by the WRDSB.

As part of the ongoing monitoring program air sampling was conducted between September, 2012 and March 2013. Analytical results from the previous sampling events are documented in MTE's previous reports.

This report should be read in conjunction with previous reports related to airborne fibre sampling at the school.

Sampling is conducted on an annual basis, as requested by the WRDSB.

## SCOPE OF WORK

The scope of MTE's services for this assignment was:

- Collection of three (3) air samples from selected corridors on the first and second floors;
- Analysis of total airborne fibre by Phase Contrast Microscopy following the National Institute of Occupational Safety and Health US (NIOSH) Method 7400;
- Interpretation of analytical results with respect to occupational worker exposure; and
- Preparation of a letter report of findings with appropriate recommendations, if required.

## METHODOLOGY

In conjunction with the ongoing management program, air samples were collected by MTE from selected locations on September 1, 2016. A total of three (3) air samples were collected. Samples were collected in accordance with The National Institute for Occupational Safety and Health (NIOSH) Method 7400 and were analyzed by MTE. MTE participates and maintains proficient standing in the Canadian Association for Laboratory Accreditation (CALA) proficiency testing in asbestos and other fibres in air by Phase Contrast Microscopy Analysis under Membership number 3827. Table 1 provides a summary of sample locations and laboratory analytical results.

**TABLE 1: SUMMARY OF AIRBORNE FIBRE CONCENTRATIONS AT SELECTED SAMPLE LOCATIONS THROUGHOUT WODSS ON SEPTEMBER 1, 2016 AS DETERMINED BY PHASE CONTRAST MICROSCOPY**

Sample Name	Sample Location	Sample Air Volume Collected (L)	Analytical Results: Fibres per cubic centimetre of Air (f/cc)
CU990730	1 <sup>st</sup> Floor Corridor 803 (outside 507)	2700	<0.007
CU990520	1 <sup>st</sup> Floor Science Classroom 102	2700	<0.007
CL993480	2 <sup>nd</sup> Floor Corridor 821 (100 Series)	2700	<0.007

## **DISCUSSION**

### **Airborne Fibres**

All three air samples collected within the selected corridor sample locations reported concentrations of total airborne fibres to be below the reporting limit of 0.007 fibres per cubic centimetre of air (f/cc).

It should be noted that the analysis method does not distinguish between asbestos fibres and other fibre sources. Sample method detection limits have been rounded to the nearest significant digit. Ontario Regulation 490/09 Designated Substances prescribes an acceptable Time Weighted Average Exposure Value (TWAEV) to asbestos fibre of not more than 0.1 fibres per cubic centimetre of air (f/cc). Standard industrial hygiene practice considers a concentration greater than one half the TWAEV (0.05 f/cc) as actionable in order to control exposure and ensure worker safety. Ontario Regulation 278/05 Designated Substance – Asbestos on Construction Projects and in Buildings and Repair Operations prescribes an acceptable post asbestos removal air clearance concentration of not more than 0.01 f/cc or one tenth the TWAEV. This concentration is deemed protective of human health for workers and occupants of the building. All samples reported concentrations of total airborne fibres to be less than the clearance criteria of 0.01 f/cc. The reported concentrations do not suggest an overexposure to airborne asbestos for workers or building occupants.

## **CONCLUSIONS AND RECOMMENDATIONS**

Based on analytical results the following conclusions are presented:

- Total airborne fibre concentrations within the sampled locations are well below the Ontario Ministry of Labour TWAEV acceptable abatement and clearance criteria prescribed in Ontario Regulation 490/09 and 278/05 respectively;
- The reported concentrations in the air samples do not indicate workers or building occupants are at any elevated risk of over-exposure to airborne asbestos fibres, under current site conditions;
- These findings should be incorporated into the building asbestos audit and Asbestos Management Program; and
- If work is required which will disturb or is likely to disturb asbestos-containing material, the work must be conducted in accordance with Ontario Regulation 278/05 by trained and certified asbestos removal contractors.

## LIMITATIONS

Services performed by **MTE Consultants Inc.** (MTE) were conducted in a manner consistent with the level of care and skill ordinarily exercised by members of the Environmental Engineering & Consulting profession. No other representation expressed or implied as to the accuracy of the information, conclusions or recommendations is included or intended in this report.

This report was completed for the sole use of MTE and Waterloo Region District School Board. It was completed in accordance with the Scope of Work. As such, this report may not deal with all issues potentially applicable to the site and may omit issues, which are or may be of interest to the reader. MTE makes no representation that the present report has dealt with all-important environmental features, except as provided in the Scope of Work. All findings and conclusions presented in this report are based on site conditions, as they existed during the time period of the investigation. This report is not intended to be exhaustive in scope or to imply a risk-free facility.

Some areas could not be investigated due to non-destructive, non-invasive, inspection restrictions or prohibited access. Although the presence of asbestos-containing materials (ACM) has been anticipated in these areas where reasonable, the accuracy of such information must be confirmed before any potential disturbance of materials which may contain asbestos. It is also possible that ACM may be visually or physically concealed by but not necessarily limited to ceilings, walls, bulkheads, floors, roof systems or other similar features or structures.

Any use which a third party makes of this report, or any reliance on, or decisions to be made based upon it, are the responsibility of such third parties. MTE accepts no responsibility for liabilities incurred by or damages, if any, suffered by any third party as a result of decisions made or actions taken, based upon this report. Others with interest in the site should undertake their own investigations and studies to determine how or if the condition affects them or their plans.

It should be recognized that the passage of time may affect the views, conclusions and recommendations (if any) provided in this report because environmental conditions of a property can change. Should additional or new information become available, MTE recommends that it be brought to our attention in order that we may re-assess the contents of this report.

Sincerely,

**MTE CONSULTANTS INC.**



Martin Mielke, B.Sc, CRSP  
Technical Advisor  
[mmielke@mte85.com](mailto:mmielke@mte85.com)

MJM:mjm

Attach:

M:\34152\104 - Phase 3\Bi-Annual Air Sampling\34152-104 - Air Sampling Report - Waterloo-Oxford D.S.S. - August 2015.doc



## ATTACHMENTS

For Tender Purposes



## PHASE CONTRAST MICROSCOPY (PCM) ANALYSIS WORKSHEET

Client: <u>WRDSB</u>	Project No.: <u>34152-900</u>
Sample ID: <u>34152-900-AAM-AS1</u>	Sample Date: <u>1-Sep-16</u>
Cassette Barcode No.: <u>CU990730</u>	Sample No.: <u>1856</u>
Project Location: <u>Waterloo Oxford DSS</u>	Sampled By: <u>MJM</u>
Analyst: <u>MJM</u>	Analysis Date: <u>2-Sep-16</u>
Approved by: <u>MJM</u>	Approval Date: <u>2-Sep-16</u>

Date & Time <b>On</b> (m/d/yyyy hr:min)*:	9/1/2016 12:55	Sample Duration (hr:min):	3:00
Date & Time <b>Off</b> (m/d/yyyy hr:min)*:	9/1/2016 15:55	Sample Duration (min):	180
Sample Flow Rate (L/min):	15.00	Sample Volume (L):	2700

Total # of Fibres Counted =	33.5	
Total # Fields Counted =	100	
Fibres per Field	0.335	
Fibres per Field (blank <7/100)	0	
Diameter of Filter	25	mm
Effective Collection Area of Filter	385	mm <sup>2</sup> (for 25 mm cassette)
Diameter of Field	0.1	mm
Field Area	0.00785	mm <sup>2</sup>

### Fibre Density = F (Fibre/mm<sup>2</sup>)

$$E = \frac{\text{Fibres per Field (sample)} \quad 0.335 \quad - \quad \text{Fibres per Field (blank)} \quad 0}{\text{Field Area} \quad 0.00785}$$

$$E = \boxed{42.68}$$

### Fibre Concentration = G Fibres/cubic centimetre (f/cc)

$$C = \frac{E \quad 42.68 \quad \times \quad \text{Effective Collection Area} \quad 385}{\text{Sample Volume (L)} \quad 2700 \quad \times \quad 1000 \quad (\text{conversion L to m}^3)}$$

$$C = \boxed{0.006} \quad (\text{f/cc}) \quad \text{R.L.} \leq \boxed{0.007} \quad (\text{f/cc})$$

**Notes:**

- \* Time displayed as 24 hour time.
- R.L. = Reporting Limit based on Quantitation Limit for Sampling Volume based on approximately 40 fibres/100 fields
- (f/cc) = fibres per cubic centimetre of air

## PHASE CONTRAST MICROSCOPY (PCM) ANALYSIS REPORT

Samples were analyzed using a Zeiss Axio Star Plus or Nikon Eclipse E100 Phase Contrast Microscope in accordance with NIOSH method 7400 "Asbestos and Other Fibres by PCM". The results of this report apply only to the materials tested.

### CLIENT INFORMATION

Client Name: **WRDSB**

Project No: **34152-900**

Client Address: 51 Ardelt Avenue, Kitchener, Ontario

Site Address: 1206 Snyders Road W, Baden, Ontario

### SAMPLING INFORMATION

Sampled by: MJM

Sampling date: 01-Sep-16

Analyzed by: MJM

Analysis date: 02-Sep-16

Analyst Signature: 

Manager's Signature: 

### SAMPLE INFORMATION

Sample #: 1856

Cassette Barcode Number: CU990730

Sample ID: **34152-900-AAM-AS1**

Fibres/field: 0.335

Flow Rate (L/min): 15.00

Cassette Size (mm<sup>2</sup>): 385

Duration (min): 180

Field Size: 0.00785

Volume (L): 2700

R.L. ≤ **0.007** (f/cc)

#### Notes:

- R.L. = Reporting Limit based on Quantitation Limit for Sampling Volume based on approximately 40 fibres/100 fields
- (f/cc) = fibres per cubic centimetre of air

### PHASE CONTRAST MICROSCOPY (PCM) ANALYSIS WORKSHEET

Client: <u>WRDSB</u>	Project No.: <u>34152-900</u>
Sample ID: <u>34152-900-AAM-AS2</u>	Sample Date: <u>1-Sep-16</u>
Cassette Barcode No.: <u>CU990520</u>	Sample No.: <u>1857</u>
Project Location: <u>Waterloo Oxford DSS</u>	Sampled By: <u>MJM</u>
Analyst: <u>MJM</u>	Analysis Date: <u>2-Sep-16</u>
Approved by: <u>MJM</u>	Approval Date: <u>2-Sep-16</u>

Date & Time <b>On</b> (m/d/yyyy hr:min)*:	9/1/2016 12:58	Sample Duration (hr:min):	3:00
Date & Time <b>Off</b> (m/d/yyyy hr:min)*:	9/1/2016 15:58	Sample Duration (min):	180
Sample Flow Rate (L/min):	15.00	Sample Volume (L):	2700

Total # of Fibres Counted =	29.5
Total # Fields Counted =	100
Fibres per Field	0.295
Fibres per Field (blank <7/100)	0
Diameter of Filter	25 mm
Effective Collection Area of Filter	385 mm <sup>2</sup> (for 25 mm cassette)
Diameter of Field	0.1 mm
Field Area	0.00785 mm <sup>2</sup>

**Fibre Density = F (Fibre/mm<sup>2</sup>)**

$$E = \frac{\text{Fibres per Field (sample)} - \text{Fibres per Field (blank)}}{\text{Field Area}}$$

E =  $\frac{0.295 - 0}{0.00785}$

E = **37.58**

**Fibre Concentration = G Fibres/cubic centimetre (f/cc)**

$$C = \frac{E \times \text{Effective Collection Area}}{\text{Sample Volume (L)} \times 1000 \text{ (conversion L to m}^3\text{)}}$$

C =  $\frac{37.58 \times 385}{2700 \times 1000}$

C = **0.005** (f/cc)

R.L. ≤ **0.007** (f/cc)

Notes:

- \* Time displayed as 24 hour time.
- R.L. = Reporting Limit based on Quantitation Limit for Sampling Volume based on approximately 40 fibres/100 fields
- (f/cc) = fibres per cubic centimetre of air

## PHASE CONTRAST MICROSCOPY (PCM) ANALYSIS REPORT

Samples were analyzed using a Zeiss Axio Star Plus or Nikon Eclipse E100 Phase Contrast Microscope in accordance with NIOSH method 7400 "Asbestos and Other Fibres by PCM". The results of this report apply only to the materials tested.

### CLIENT INFORMATION

Client Name: **WRDSB**

Project No: **34152-900**

Client Address: 51 Ardelt Avenue, Kitchener, Ontario

Site Address: 1206 Snyders Road W, Baden, Ontario

### SAMPLING INFORMATION

Sampled by: MJM

Sampling date: 01-Sep-16

Analyzed by: MJM

Analysis date: 02-Sep-16

Analyst Signature: 

Manager's Signature: 

### SAMPLE INFORMATION

Sample #: 1857

Cassette Barcode Number: CU990520

Sample ID: **34152-900-AAM-AS2**

Fibres/field: 0.295

Flow Rate (L/min): 15.00

Cassette Size (mm<sup>2</sup>): 385

Duration (min): 180

Field Size: 0.00785

Volume (L): 2700

R.L. ≤ **0.007** (f/cc)

#### Notes:

- R.L. = Reporting Limit based on Quantitation Limit for Sampling Volume based on approximately 40 fibres/100 fields
- (f/cc) = fibres per cubic centimetre of air



## PHASE CONTRAST MICROSCOPY (PCM) ANALYSIS WORKSHEET

Client: <u>WRDSB</u>	Project No.: <u>34152-900</u>
Sample ID: <u>34152-900-AAM-AS3</u>	Sample Date: <u>1-Sep-16</u>
Cassette Barcode No.: <u>CU990480</u>	Sample No.: <u>1858</u>
Project Location: <u>Waterloo Oxford DSS</u>	Sampled By: <u>MJM</u>
Analyst: <u>MJM</u>	Analysis Date: <u>2-Sep-16</u>
Approved by: <u>MJM</u>	Approval Date: <u>2-Sep-16</u>

Date & Time <b>On</b> (m/d/yyyy hr:min)*:	9/1/2016 12:58	Sample Duration (hr:min):	3:00
Date & Time <b>Off</b> (m/d/yyyy hr:min)*:	9/1/2016 15:58	Sample Duration (min):	180
Sample Flow Rate (L/min):	15.00	Sample Volume (L):	2700

Total # of Fibres Counted =	35.5	
Total # Fields Counted =	100	
Fibres per Field	0.355	
Fibres per Field (blank <7/100)	0	
Diameter of Filter	25	mm
Effective Collection Area of Filter	385	mm <sup>2</sup> (for 25 mm cassette)
Diameter of Field	0.1	mm
Field Area	0.00785	mm <sup>2</sup>

### Fibre Density = F (Fibre/mm<sup>2</sup>)

$$E = \frac{\text{Fibres per Field (sample)} \times \text{Field Area} - \text{Fibres per Field (blank)} \times \text{Field Area}}{\text{Field Area}}$$

E = 45.22

### Fibre Concentration = G Fibres/cubic centimetre (f/cc)

$$C = \frac{E \times \text{Effective Collection Area}}{\text{Sample Volume (L)} \times 1000 \text{ (conversion L to m}^3\text{)}}$$

C = 0.006 (f/cc)

R.L. ≤ 0.007 (f/cc)

**Notes:**

- \* Time displayed as 24 hour time.
- R.L. = Reporting Limit based on Quantitation Limit for Sampling Volume based on approximately 40 fibres/100 fields
- (f/cc) = fibres per cubic centimetre of air

## PHASE CONTRAST MICROSCOPY (PCM) ANALYSIS REPORT

Samples were analyzed using a Zeiss Axio Star Plus or Nikon Eclipse E100 Phase Contrast Microscope in accordance with NIOSH method 7400 "Asbestos and Other Fibres by PCM". The results of this report apply only to the materials tested.

### CLIENT INFORMATION

Client Name: **WRDSB**

Project No: **34152-900**

Client Address: 51 Ardelt Avenue, Kitchener, Ontario

Site Address: 1206 Snyders Road W, Baden, Ontario

### SAMPLING INFORMATION

Sampled by: MJM

Sampling date: 01-Sep-16

Analyzed by: MJM

Analysis date: 02-Sep-16

Analyst Signature: 

Manager's Signature: 

### SAMPLE INFORMATION

Sample #: 1858

Cassette Barcode Number: CU990480

Sample ID: **34152-900-AAM-AS3**

Fibres/field: 0.355

Flow Rate (L/min): 15.00

Cassette Size (mm<sup>2</sup>): 385

Duration (min): 180

Field Size: 0.00785

Volume (L): 2700

R.L. ≤ **0.007** (f/cc)

#### Notes:

- R.L. = Reporting Limit based on Quantitation Limit for Sampling Volume based on approximately 40 fibres/100 fields
- (f/cc) = fibres per cubic centimetre of air

## PROJECT INFORMATION

<b>Inspection Date:</b>	September 6, 2017	<b>Project No.:</b>	100106.005
<b>Report Issue Date:</b>	September 7, 2017		
<b>Project Name:</b>	Asbestos Air Monitoring		
<b>Site Address:</b>	Waterloo-Oxford District Secondary School, 1206 Snyder's Road West, Baden, ON		
<b>Client:</b>	Waterloo Region District School Board (WRDSB)		
<b>Client Supervisor:</b>	Daniela Budure, Environmental Officer		
<b>OnPoint Inspector:</b>	Sean Hauck		
<b>Arrival Time:</b>	5:15 pm	<b>Departure Time:</b>	9:00 pm
		<b>No. of Workers:</b>	n/a

## DISTRIBUTION

**Issued to:** Daniela Budure      WRDSB      [daniela\\_budure@wrdsb.on.ca](mailto:daniela_budure@wrdsb.on.ca)

## WORK AREAS + DESCRIPTION OF WORK

- Subject Areas      OnPoint Environmental Solutions (OnPoint) was retained by the Waterloo Region District School Board (WRDSB) to perform proactive air testing to document the airborne fibre levels (including asbestos) within the following locations (hereafter referred to as the subject areas):
- Corridor adjacent Room 515
  - Corridor adjacent Room 203
  - Corridor adjacent Room 102
  - **Air Monitoring – ACCEPTABLE**

## FIELD OBSERVATIONS

- Subject Areas      **Methodology**
- OnPoint collected air samples for airborne fibre (including asbestos) analysis using 25mm Mixed Cellulose Ester (MCE) cassettes with 0.8 micrometer (µm) pore size and Allegro high volume sample pumps calibrated to a flow rate of approximately 15 litres per minute (L/min).
  - All samples were analysed following the Phase Contrast Microscopy (PCM) method as specified in the NIOSH 7400 method. The PCM method does not allow discrimination between asbestos and non-asbestos fibres. All fibres that meet the counting criteria are included in the count. Using the fibre count data and the sampling volume, an estimate of the average airborne fibre concentration during the sampling period was made.

## Results

- All air samples reported concentrations of total fibres to be less than 0.01 fibres per cubic centimetre (f/cc) of air. Ontario Regulation 490/09 Designated Substances prescribes an acceptable Time Weighted Average Exposure Value (TWAEV) for asbestos fibre of not more than 0.1 f/cc. The reported concentrations (<0.01 f/cc) indicate that airborne fibre (including asbestos) levels within the subject areas are well below the criterion noted above. One field blank was collected for quality control purposes. Analysis of the field blank showed 0 fibres per 100 fields counted.
- Photographs of the air monitoring equipment are provided below.

### AIR MONITORING RESULTS – Phase Contrast Microscopy (PCM)\*

Type	Sample No.	Sampling Location	Start Time	Stop Time	Flow Rate (L/min)	Duration (Minutes)	Air Volume (L)	Result (f/cc of air)
OC	CZ370501	Corridor adjacent Room 515	5:30 pm	8:30 pm	15	180	2,700	< 0.01
OC	CZ370429	Corridor adjacent Room 203	5:40 pm	8:35 pm	15	175	2,625	< 0.01
OC	CZ370414	Corridor adjacent Room 102	5:45 pm	8:40 pm	15	175	2,625	< 0.01
QC	CZ370379	Field Blank	N/A	N/A	N/A	N/A	N/A	0 fibres/100 fields

**Notes:**

- OCCUPIED (OC)** Area samples were collected in regularly occupied spaces (i.e., not within an asbestos abatement work area).
- QUALITY CONTROL (QC)** Field blank samples were collected in a manner representing the actual handling of associated samples in a sample set for quality control purposes.
- f/cc** fibres per cubic centimeter of air
- L/min** litres/minute
- \*** Air monitoring and analysis was performed following the NIOSH 7400 method using Phase Contrast Microscopy (PCM)

### CONCLUSION

PCM analysis of the collected air samples confirmed airborne fibre concentrations (including asbestos) were within the acceptable range (i.e., below 0.1 fibres/cc of air). As such, the subject areas are acceptable for continued occupancy.

[https://onpointes-my.sharepoint.com/personal/aandriotis\\_onpointenvironmental\\_com/documents/onpoint es/projects/100106\\_wrdsb/005\\_rfpacmairstvarious/sites/waterloo oxford/inspection rpt/100106.005 air sampling waterloo-oxford s.s. baden on wrdsb sept 7 2017.docx](https://onpointes-my.sharepoint.com/personal/aandriotis_onpointenvironmental_com/documents/onpoint%20es/projects/100106_wrdsb/005_rfpacmairstvarious/sites/waterloo%20oxford/inspection%20rpt/100106.005%20air%20sampling%20waterloo-oxford%20s.s.%20baden%20on%20wrdsb%20sept%207%202017.docx)

## PHOTOGRAPHS



**Photo 1:** Air monitoring equipment  
Corridor adjacent Room 515.



**Photo 2:** Air monitoring equipment  
Corridor adjacent Room 203.



**Photo 3:** Air monitoring equipment  
Corridor adjacent Room 102.

## PROJECT INFORMATION

<b>Inspection Date:</b>	August 21, 2019	<b>Project No.:</b>	100106.029
<b>Project Name:</b>	Occupied Air Monitoring for Asbestos Fibres		
<b>Site Address:</b>	Waterloo-Oxford District Secondary School, 1206 Snyder's Road West, Baden, ON		
<b>Client:</b>	Waterloo Region District School Board (WRDSB)		
<b>Client Supervisor:</b>	Daniela Budure, Environmental Officer		
<b>OnPoint Inspector:</b>	David Niemand		
<b>Arrival Time:</b>	2:50 pm	<b>Departure Time:</b>	6:10 pm
		<b>No. of Workers:</b>	n/a

## DISTRIBUTION

<b>Issued to:</b>	Daniela Budure	WRDSB	daniela_budure@wrdsb.on.ca
-------------------	----------------	-------	----------------------------

## WORK AREAS + DESCRIPTION OF WORK

**Subject Areas** OnPoint Environmental Solutions Inc. (OnPoint) was retained by the Waterloo Region District School Board (WRDSB) to perform proactive air testing to document the airborne fibre levels (including asbestos) within the following locations (hereafter referred to as the subject areas):

- Corridor (adjacent Room 508)
- Corridor (adjacent Room 203)
- Corridor (adjacent Room 102)

The air monitoring was requested as part of an ongoing program to assess airborne asbestos fibre concentrations in occupied areas of the school in conjunction with ongoing asbestos management.

- **Air Monitoring – ACCEPTABLE**

## FIELD OBSERVATIONS

Subject Areas	Methodology
	<ul style="list-style-type: none"> <li>● OnPoint collected air samples for airborne fibre (including asbestos) analysis using 25mm Mixed Cellulose Ester (MCE) cassettes with 0.8 micrometer (<math>\mu\text{m}</math>) pore size and Allegro high-volume sample pumps calibrated to a flow rate of approximately 15 litres per minute (L/min).</li> <li>● All samples were analysed following the Phase Contrast Microscopy (PCM) method as specified in the NIOSH 7400 method. The PCM method does not allow discrimination between asbestos and non-asbestos fibres. All fibres that meet the counting criteria are included in the count. Using the fibre count data and the sampling volume, an estimate of the average airborne fibre concentration during the sampling period was made.</li> </ul>

## Results

- All air samples reported concentrations of total fibres to be less than 0.01 fibres per cubic centimetre (f/cc) of air. Ontario Regulation 490/09 Designated Substances prescribes an acceptable Time Weighted Average Exposure Value (TWAEV) for asbestos fibre of not more than 0.1 f/cc. The reported concentrations (<0.01 f/cc) indicate that airborne fibre (including asbestos) levels within the subject areas are well below the criterion noted above. One field blank was collected for quality control purposes. Analysis of the field blank showed 0 fibres per 100 fields counted.
- Photographs of the air monitoring equipment are provided below.

### AIR MONITORING RESULTS – Phase Contrast Microscopy (PCM)\*

Type	Sample No.	Sampling Location	Start Time	Stop Time	Flow Rate (L/min)	Duration (Minutes)	Air Volume (L)	Result (f/cc of air)
OC	CN659715	Corridor (adjacent Class 508)	2:53 pm	5:52 pm	15	179	2,685	< 0.01
OC	CN659724	Corridor (adjacent Class 203)	2:58 pm	5:58 pm	15	180	2,700	< 0.01
OC	CN659727	Corridor (adjacent Class 102)	3:04 pm	6:02 pm	15	178	2,670	< 0.01
QC	CN659714	Field Blank	N/A	N/A	N/A	N/A	N/A	0 fibres/100 fields

#### Notes:

- OCCUPIED (OC)** Area samples were collected in regularly occupied spaces (i.e., not within an asbestos abatement work area).
- QUALITY CONTROL (QC)** Field blank samples were collected in a manner representing the actual handling of associated samples in a sample set for quality control purposes.
- f/cc** fibres per cubic centimeter of air
- L/min** litres/minute
- \* Air monitoring and analysis was performed following the NIOSH 7400 method using Phase Contrast Microscopy (PCM)

### CONCLUSION

PCM analysis of the collected air samples confirmed airborne fibre concentrations (including asbestos) were within the acceptable range (i.e., below 0.1 fibres/cc of air). As such, the subject areas are acceptable for continued occupancy.

[https://onpointes-my.sharepoint.com/personal/aandriotis\\_onpointenvironmental\\_com/documents/onpoint\\_es/projects/100100/100106\\_wrdsb/029\\_acmairstestvarious/sites/waterloo\\_oxford/inspection\\_rpt/100106\\_029\\_air\\_sampling\\_waterloo-oxford\\_ss\\_baden\\_on\\_wrdsb\\_aug\\_21\\_2019.docx](https://onpointes-my.sharepoint.com/personal/aandriotis_onpointenvironmental_com/documents/onpoint_es/projects/100100/100106_wrdsb/029_acmairstestvarious/sites/waterloo_oxford/inspection_rpt/100106_029_air_sampling_waterloo-oxford_ss_baden_on_wrdsb_aug_21_2019.docx)

## PHOTOGRAPHS



**Photo 1:** Air monitoring equipment - Corridor (adjacent Room 508).



**Photo 2:** Air monitoring equipment - Corridor (adjacent Room 203).



**Photo 3:** Air monitoring equipment - Corridor (adjacent Room 102).

April 27, 2022

MTE File No.: C34532-936

Waterloo Region District School Board  
51 Ardelt Avenue  
Kitchener, ON N2C 2R5

**RE: Results of Total Airborne Fibre Sampling at  
Waterloo Oxford District Secondary School  
1206 Snyder's Road West, Baden, Ontario**

MTE Consultants Inc. (MTE) was retained by the Waterloo Region District School Board (WRDSB) to complete a sampling program for airborne fibres in conjunction with ongoing asbestos management at Waterloo Oxford District Secondary School (WODSS) located at 1206 Snyder's Road West in Baden, Ontario.

## Background

In September 2012, inspection services, documentation, and air monitoring programs were developed and conducted by MTE. A portion of the above mentioned monitoring program included ongoing sampling for total airborne fibre analysis by Phase Contrast Microscopy (PCM) to assess any potential risk of building occupant exposure to airborne asbestos fibres. Air sampling will continue as part of the ongoing monitoring program, and sampling will be conducted on a bi-annual basis, as requested by the WRDSB.

As part of the ongoing monitoring program air sampling was conducted between September, 2012, March 2013 and August 2016. Analytical results from the previous sampling events are documented in MTE's previous reports.

This report should be read in conjunction with previous reports related to airborne fibre sampling at the school.

Sampling is conducted on an annual basis, as requested by the WRDSB.

## Scope of Work

The scope of MTE's services for this assignment was:

- Collection of three (3) air samples from selected locations on the First and Second Floors in accordance with the National Institute for Occupational Safety and Health (NIOSH) Method 7400;
- Submission of samples to an accredited and/or qualified laboratory for PCM Analysis;
- Interpretation of analytical results with respect to occupational worker exposure; and
- Preparation of a letter report of findings with appropriate recommendations, if required.

## Methodology

In conjunction with the ongoing management program, air samples were collected by MTE from selected locations on April 5, 2022. A total of three (3) air samples were collected. Samples were collected in accordance with The National Institute for Occupational Safety and Health (NIOSH) Method 7400 and were analyzed by Paracel Laboratories Inc. Paracel participates and maintains proficient standing in the Canadian Association for Laboratory Accreditation (CALA) proficiency testing in asbestos and other fibres in air by Phase Contrast Microscopy Analysis under Membership number 3762. Table 1 provides a summary of sample locations and laboratory analytical results.

Table 1: Summary of Airborne Fibre Concentrations at Selected Sample Locations throughout WODSS on April 4, 2022 As Determined By Phase Contrast Microscopy

Sample Name	Sample Location	Sample Air Volume Collected (L)	Analytical Results: Fibres per cubic centimetre of Air (f/cc)
AC1-WODSS	Corridor 801 @ Room 103	2,400	0.002
AC2-WODSS	Room 123	2,400	<0.001
AC3-WODSS	Corridor 810 @ Room 507	2,400	<0.001

## Discussion

### Airborne Fibres

All three air samples collected reported concentrations of total airborne fibres to be below 0.01 fibres per cubic centimetre of air (f/cc). Two of the three samples reported below the laboratory detection limit of 0.001 f/cc.

It should be noted that the analysis method does not distinguish between asbestos fibres and other fibre sources. Sample method detection limits have been rounded to the nearest significant digit. Ontario Regulation 490/09 Designated Substances prescribes an acceptable Time Weighted Average Exposure Value (TWAEV) to asbestos fibre of not more than 0.1 fibres per cubic centimetre of air (f/cc). Standard industrial hygiene practice considers a concentration greater than one half the TWAEV (0.05 f/cc) as actionable in order to control exposure and ensure worker safety. Ontario Regulation 278/05 Designated Substance – Asbestos on Construction Projects and in Buildings and Repair Operations prescribes an acceptable post asbestos removal air clearance concentration of not more than 0.01 f/cc or one tenth the TWAEV. This concentration is deemed protective of human health for workers and occupants of the building. All samples reported concentrations of total airborne fibres to be below the clearance criteria of 0.01 f/cc. The reported concentrations do not suggest an overexposure to airborne asbestos for workers or building occupants.

It should be noted that asbestos-containing spray-applied fireproofing still exists within the building. The results of the current and historical air sampling do not imply a risk-free facility and all work which may disturb spray-applied fireproofing, other asbestos-containing materials and potentially asbestos-contaminated infrastructure, must be conducted in compliance with Ontario Regulation 278/05.

## Conclusions and Recommendations

Based on analytical results the following conclusions are presented:

- Total airborne fibre concentrations within the sampled locations are well below the Ontario Ministry of Labour TWAEV acceptable abatement and clearance criteria prescribed in Ontario Regulation 490/09 and 278/05 respectively.
- The reported concentrations in the air samples do not suggest workers or building occupants are at any elevated risk of over exposure to airborne asbestos fibres, under current site conditions.
- These findings should be incorporated into the building asbestos audit and Asbestos Management Program.
- If work is required which will disturb or is likely to disturb asbestos-containing material, the work must be conducted in accordance with Ontario Regulation 278/05 by trained and certified asbestos removal contractors.

For Tender Purposes

## Limitation

Services performed by **MTE Consultants Inc.** (MTE) were conducted in a manner consistent with the level of care and skill ordinarily exercised by members of the Environmental Engineering & Consulting profession. No other representation expressed or implied as to the accuracy of the information, conclusions or recommendations is included or intended in this report.

This report was completed for the sole use of MTE and Waterloo Region District School Board. It was completed in accordance with the Scope of Work. As such, this report may not deal with all issues potentially applicable to the site and may omit issues, which are or may be of interest to the reader. MTE makes no representation that the present report has dealt with all-important environmental features, except as provided in the Scope of Work. All findings and conclusions presented in this report are based on site conditions, as they existed during the time period of the investigation. This report is not intended to be exhaustive in scope or to imply a risk-free facility.

Some areas could not be investigated due to non-destructive, non-invasive, inspection restrictions or prohibited access. Although the presence of asbestos-containing materials (ACM) has been anticipated in these areas where reasonable, the accuracy of such information must be confirmed before any potential disturbance of materials which may contain asbestos. It is also possible that ACM may be visually or physically concealed by but not necessarily limited to ceilings, walls, bulkheads, floors, roof systems or other similar features or structures.

Any use which a third party makes of this report, or any reliance on, or decisions to be made based upon it, are the responsibility of such third parties. MTE accepts no responsibility for liabilities incurred by or damages, if any, suffered by any third party as a result of decisions made or actions taken, based upon this report. Others with interest in the site should undertake their own investigations and studies to determine how or if the condition affects them or their plans.

It should be recognized that the passage of time may affect the views, conclusions and recommendations (if any) provided in this report because environmental conditions of a property can change. Should additional or new information become available, MTE recommends that it be brought to our attention in order that we may re-assess the contents of this report.

Yours truly,

**MTE Consultants Inc.**



**Jason Scozzafava, B.Sc., C.Tech.**

Senior Technologist, Indoor Environments  
519-743-6500 ext. 1354

[jscozzafava@mte85.com](mailto:jscozzafava@mte85.com)



**Martin Mielke, B.Sc., CRSP**

Technical Practice Leader, Indoor Environments  
519-743-6500 ext. 1318

[mmielke@mte85.com](mailto:mmielke@mte85.com)

JAS: apm

Attach

M:\34532\936\WODSS\34532-936\_2022-04-27\_RptAirSampling\_WODSS.docx

## Certificate of Analysis

### MTE Consultants Inc. (Kitchener)

520 Bingemans Centre Dr.  
Kitchener, ON N2B 3X9  
Attn: Paul Semeniuk

Client PO: 34532-936

Project: 34532-936 WODSS

Custody:

Report Date: 12-Apr-2022

Order Date: 7-Apr-2022

**Order #: 2215474**

This Certificate of Analysis contains analytical data applicable to the following samples as submitted:

Parcel ID	Client ID
2215474-01	AC1-WODSS - Cor 801
2215474-02	AC2-WODSS - Rm 123
2215474-03	AC3-WODSS - Cor 810

Approved By:



Emma Diaz

Senior Analyst

Any use of these results implies your agreement that our total liability in connection with this work, however arising, shall be limited to the amount paid by you for this work, and that our employees or agents shall not under any circumstances be liable to you in connection with this work.

Certificate of Analysis  
 Client: MTE Consultants Inc. (Kitchener)  
 Client PO: 34532-936

Report Date: 12-Apr-2022  
 Order Date: 7-Apr-2022  
 Project Description: 34532-936 WODSS

**Asbestos - Air PCM Fiber Count**

Parcel ID	Sample Date	Air Volume(L)	Fields Read	Fibers Detected	Fibers/mm2	LOD (f/cc)	Fibers/cc	Sample Notes
<b>Client ID: AC1-WODSS - Cor 801</b>								
2215474-01	04-Apr-22	2400	100	10.0	12.74	0.001	<b>0.002</b>	
<b>Client ID: AC2-WODSS - Rm 123</b>								
2215474-02	04-Apr-22	2400	100	4.0	5.1	0.001	<b>&lt;0.001</b>	
<b>Client ID: AC3-WODSS - Cor 810</b>								
2215474-03	04-Apr-22	2400	100	1.0	1.27	0.001	<b>&lt;0.001</b>	

\* Sample results for fiber density (Fibers/mm2) and concentration (Fibers/cc) have been corrected for field blank data if available.

**Analysis Summary Table**

Analysis	Method Reference/Description	Lab Location	Analysis Date
Asbestos and Other Fibers by PCM	NIOSH 7400 - Asbestos and Other Fibers by PCM	1 - Mississauga	12-Apr-22

Mississauga Lab: 15 - 6800 Kitimat Rd Mississauga, Ontario, L5N 5M1

**Work Order Revisions | Comments**

None  
 NOTE: Sample volume was provided by the client and has been used in the calculations. This can affect the validity of the final result.

For Tender Purposes

2215474



Office  
319 St. Laurent Blvd.  
K1G 4J8  
100-749-1947  
racel@paracellabs.com

**Chain of Custody**  
(Lab Use Only)

Page \_\_\_ of \_\_\_

Client Name: MTE Consultants Inc. Project Reference: WODSS  
 Contact Name: Paul Semeniuk Quote #: 22-084 MTE Standing Offer  
 Address: 520 Bingmans Centre Drive PO #: 34532-936  
 Kitchener ON N2B 3X9 Email Address: jscozzafava@mte85.com  
 Telephone: 519-743-6500 psemienuk@mte85.com

**Turnaround Time:**

Immediate  1 Day  
 4 Hour  2 Day  
 8 Hour  3 Day  
 Regular

Date Required: \_\_\_\_\_

**ASBESTOS & MOLD ANALYSIS**

Matrix:  Air  Bulk  Tape Lift  Swab  Other  
 Analyses:  Microscopic Mold  Culturable Mold  Bacteria GRAM  PCM Asbestos  PLM Asbestos  Chatfield Asbestos  TEM Asbestos  
 Regulatory Guideline:  ON  QC  AB  SK  Other  
 Parcel Order Number: 2215474

Sample ID	Sampling Date	Air Volume (L)	Analysis Required	Identify Distinct Building Materials to Be Analyzed (if not specified, all materials identified will be analyzed) *	Positive Stop?
1 AC1-WODSS-Cor 801					
2 AC2-WODSS-Rm 123	4/4/2022	2400	PCM		
3 AC3-WODSS-Cor 810	4/4/2022	2400	PCM		
4	4/4/2022	2400	PCM		
5					
6					
7					
8					
9					
10					
11					
12					

\* If left blank, all distinct materials identified in the samples will be analyzed and reported separately as per EPA 600/R-93/116. Additional charges will apply.

Comments: \_\_\_\_\_

Relinquished By (Sign): *[Signature]* Received at Depot: \_\_\_\_\_ Received at Lab: *[Signature]* Method of Delivery: *[Signature]*  
 Relinquished By (Print): Jason Scozzafava Verified By: *[Signature]*  
 Date/Time: April 6, 2022 Date/Time: Apr 7/22 Date/Time: Apr 7/22

12.47 13.44

Client Name: MTE Consultants Inc.	Project Reference: WODSS
Contact Name: Paul Semeniuk	Quote #: 22-084 MTE Standing Offer
Address: 520 Bingmans Centre Drive Kitchener ON N2B 3X9	PO #: 34532-936
	Email Address: jscozzafava@@mte85.com
Telephone: 519-743-6500	psemeniuk@mte85.com

**Turnaround Time:**

Immediate       1 Day  
 4 Hour           2 Day  
 8 Hour           3 Day  
 Regular

Date Required: \_\_\_\_\_

**ASBESTOS & MOLD ANALYSIS**

**Matrix:**  Air    Bulk    Tape Lift    Swab    Other   **Regulatory Guideline:**  ON    QC    AB    SK    Other:

**Analyses:**  Microscopic Mold    Culturable Mold    Bacteria GRAM    PCM Asbestos    PLM Asbestos    Chatfield Asbestos    TEM Asbestos

Paracel Order Number:		Asbestos - Bulk				
Sample ID		Sampling Date	Air Volume (L)	Analysis Required	Identify Distinct Building Materials to Be Analyzed (if not specified, all materials identified will be analyzed) *	Positive Stop?
1	AC1-WODSS-Cor 801	4/4/2022	2400	PCM		<input type="checkbox"/>
2	AC2-WODSS-Rm 123	4/4/2022	2400	PCM		<input type="checkbox"/>
3	AC3-WODSS-Cor 810	4/4/2022	2400	PCM		<input type="checkbox"/>
4						<input type="checkbox"/>
5						<input type="checkbox"/>
6						<input type="checkbox"/>
7						<input type="checkbox"/>
8						<input type="checkbox"/>
9						<input type="checkbox"/>
10						<input type="checkbox"/>
11						<input type="checkbox"/>
12						<input type="checkbox"/>

\* If left blank, all distinct materials identified in the samples will be analyzed and reported separately as per EPA 600/R-93/116. Additional charges will apply.

Comments: \_\_\_\_\_ Method of Delivery: \_\_\_\_\_

Relinquished By (Sign):	Received at Depot:	Received at Lab:	Verified By:
Relinquished By (Print): Jason Scozzafava			
Date/Time: April 6, 2022	Date/Time:	Date/Time:	Date/Time:



1-220 Spring Valley Rd.  
Kitchener, ON N2H 5X8  
Waterloo Region (519) 578-0200 Toronto (416) 283-2673  
office@ddkductcleaning.com

---

## *Certificate of Completion*

This is to verify that work has been completed at:

Waterloo Oxford District Secondary School  
1206 Snyder Rd. W., Baden

Work completed on: November 29th & 30th, 2022

Description:

Cleaned ground floor return/exhaust air ductwork, grilles and diffusers serving the "100" wing classrooms/teachers rooms and back to the drops from the AHU above.



The HVAC Inspection, Maintenance  
and Restoration Association



1-220 Spring Valley Rd.  
Kitchener, ON N2H 5X8  
Waterloo Region (519) 578-0200 Toronto (416) 283-2673  
office@ddkductcleaning.com

---

## *Certificate of Completion*

This is to verify that work has been completed at:

Waterloo Oxford District Secondary School

1206 Snyder Rd. W., Baden

Work completed on: January 3-5, 2023

Description:

Cleaned second floor return/exhaust air ductwork, grilles and diffusers serving the "100" wing classrooms rooms and back to the AHU in the mechanical room.



The HVAC Inspection, Maintenance  
and Restoration Association

**Appendix 01 35 43B Lead Report**

**NOT APPLICABLE**

## 01 42 00 – References

### 1.0 GENERAL

#### 1.1. SECTION INCLUDES

- .1 References and standards.
- .2 Standards producing industry organizations and their addresses.

#### 1.2. RELATED SECTIONS

- .1 Section 01 61 00 – Product Requirements.
- .2 This Section describes requirements applicable to all Sections within Divisions 02 to 49.

#### 1.3. REFERENCES

- .1 For Products or quality specified by association, trade, or other references or consensus standards, comply with requirements of the standard, except when more rigid requirements are specified or are required by applicable codes.
- .2 Conform to reference standard by Ontario Building Code except where a specific date is established or required by code.
- .3 Obtain copies of standards where required by product specification sections.
- .4 Neither the contractual relationships, duties, or responsibilities of the parties in Contract nor those of the Consultant shall be altered from the Contract Documents by mention or inference otherwise, in any reference document.

#### 1.4. STANDARDS

- .1 The following associations and organizations are cited in Specification Sections. Acronym, name, address, and Internet URL addresses are as follows:
- .2 Canadian Organizations:
  - .1 **ACEC** – Association of Consulting Engineering Companies – Canada, 130 Albert Street, Suite 420, Ottawa, ON K1P 5G4; URL: <http://www.acec.ca>.
  - .2 **AWMAC** - Architectural Woodwork Manufacturers Association of Canada, 516-4 Street West, High River, AB T1V 1B6; URL: <http://www.awmac.com>.
  - .3 **Canada Green Building Council**, 330 - 55 rue Murray Street, Ottawa, ON. K1N5M3; Tel: 613-241-1184, Fax: 613-241-5750; URL: <http://www.cagbc.org>.
  - .4 **CCA** - Canadian Construction Association, 75 Albert St., Suite 400, Ottawa, ON K1P 5E7; URL: <http://www.cca-acc.com>.

- 
- .5 **CCDC** – Canadian Construction Documents Committee, Refer to ACEC, CCA, CSC or RAIC; URL: <http://www.CCDC.org>.
  - .6 **CGA** - Canadian Gas Association, 20 Eglinton Avenue West, Suite 1305, Toronto, ON M4R 1K8; URL: <http://www.cga.ca>.
  - .7 **CGSB** - Canadian General Standards Board, Place du Portage, Phase III, 6B1, 11 Laurier Street, Hull, QC K1A 0S5; URL: <http://w3.pwgsc.gc.ca/cgsb>.
  - .8 **CISC** - Canadian Institute of Steel Construction, 201 Consumers Road, Suite 300, Willowdale, ON M2J 4G8; URL: <http://www.cisc-icca.ca>.
  - .9 **CLA** - Canadian Lumbermen's Association, 27 Goulburn Avenue, Ottawa, ON K1N 8C7; URL: <http://www.cla-ca.ca>.
  - .10 **CNLA** - Canadian Nursery Landscape Association, RR #4, Stn. Main, 7856 Fifth Street, Milton, ON L9T 2X8; URL: <http://www.canadanursery.com>.
  - .11 **CRCA** - Canadian Roofing Contractors Association, 155 Queen Street, Suite 1300, Ottawa, ON K1P 6L1; URL: <http://www.roofingcanada.com>.
  - .12 **CSA** - Canadian Standards Association International, 178 Rexdale Blvd., Toronto, ON M9W 1R3; URL: <http://www.csa-international.org>.
  - .13 **CSC** - Construction Specifications Canada, 120 Carlton Street, Suite 312, Toronto, ON M5A 4K2; URL: <http://www.csc-dcc.ca>.
  - .14 **CSDMA** - Canadian Steel Door Manufacturers Association, One Yonge Street, Suite 1801, Toronto, ON M5E 1W7; URL: <http://www.csdma.org>.
  - .15 **CSPI** - Corrugated Steel Pipe Institute, 652 Bishop Street N, Unit 2A, Cambridge, ON N3H 4V6; URL: <http://www.cspi.ca>.
  - .16 **CSSBI** - Canadian Sheet Steel Building Institute, 652 Bishop St. N., Unit 2A, Cambridge, ON N3H 4V6; URL: <http://www.cssbi.ca>.
  - .17 **CUFCA** - Canadian Urethane Foam Contractor's Association, Box 3214, Winnipeg, MB R3C 4E7; URL: <http://www.cufca.ca>.
  - .18 **CWC** - Canadian Wood Council, 1400 Blair Place, Suite 210, Ottawa, ON. K1J 9B8; URL: <http://www.cwc.ca>.
  - .19 **EC** - Environment Canada, Conservation and Protection, Inquiry Centre, 351 St. Joseph Blvd, Hull, QC KIA 0H3; URL: <http://www.ec.gc.ca>.
  - .20 **EFC** - Electro Federation of Canada, 5800 Explorer Drive, Suite 200, Mississauga, ON L4W 5K9; URL: <http://www.electrofed.com>.
  - .21 **MPI** - The Master Painters Institute, 4090 Graveley Street, Burnaby, BC V5C 3T6; URL: <http://www.paintinfo.com>.
  - .22 **NABA** - National Air Barrier Association, PO Box 2747, Winnipeg, MB R3C 4E7; URL: <http://www.naba.ca>.

- 
- .23 **NLGA** - National Lumber Grades Authority, 406-First Capital Place, 960 Quayside Drive, New Westminster, BC V3M 6G2; URL: <http://www.nlga.org>.
  - .24 **NRC** - National Research Council, Building M-58, 1200 Montreal Road, Ottawa, ON K1A 0R6; URL: <http://www.nrc.gc.ca>.
  - .25 **QPL** - Qualification Program List, c/o Canadian General Standards Board, Place du Portage, Phase III, 6B1, 11 Laurier Street, Hull, QC K1A 1G6; URL: <http://www.pwgsc.gc.ca/cgsb>.
  - .26 **RAIC** - Royal Architectural Institute of Canada, 55 Murray Street, Suite 330, Ottawa, ON K1N 5M3; URL: <http://www.raic.org>.
  - .27 **SCC** - Standards Council of Canada, 270 Albert Street, Suite 2000, Ottawa, ON K1P 6N7; URL: <http://www.scc.ca>.
  - .28 **TTMAC** - Terrazzo, Tile and Marble Association of Canada, 30 Capston Gate, Unit 5 Concord, ON L4K 3E8; URL: <http://www.ttmac.com>.
  - .29 **ULC** - Underwriters' Laboratories of Canada, 7 Crouse Road, Toronto, ON M1R 3A9; URL: <http://www.ulc.ca>.
  - .3 USA Organizations:
    - .1 **AA** - Aluminum Association, 900 19th Street N.W., Washington, DC 20006; URL: <http://www.aluminum.org>.
    - .2 **AASHTO** - American Association of State Highway and Transportation Officials, 444 N Capitol Street N.W., Suite 249, Washington, DC 20001; URL: <http://www.aashto.org>.
    - .3 **AHA** - American Hardboard Association, 1210W Northwest Hwy, Palatine, IL 60067; URL: <http://www.hardboard.org>.
    - .4 **AITC** - American Institute of Timber Construction, 7012 S. Revere Parkway, Suite 140, Englewood, CO 80112; URL: <http://www.aitc-glulam.org>.
    - .5 **AMCA** - Air Movement and Control Association Inc., 30 West University Drive, Arlington Heights, IL 60004-1893; URL: <http://www.amca.org>.
    - .6 **ANSI** - American National Standards Institute, 25 West 43rd Street, 4th Floor, New York, NY 10036; URL: <http://www.ansi.org>.
    - .7 **APA** - The Engineered Wood Association, P.O. Box 11700, Tacoma, WA 98411-0700; URL: <http://www.apawood.org>.
    - .8 **API** - American Petroleum Institute, 1220 L St. Northwest, Washington, DC 20005-4070; URL: <http://www.api.org>.
    - .9 **ARI** - Air Conditioning and Refrigeration Institute, 4100 N Fairfax Drive, Suite 200, Arlington, VA 22203; URL: <http://www.ari.org>.

- 
- .10 **ASHRAE** - American Society of Heating, Refrigeration and Air-Conditioning Engineers, 1791 Tullie Circle NE, Atlanta, GA 30329; URL: <http://www.ashrae.org>.
  - .11 **ASME** - American Society of Mechanical Engineers, ASME Headquarters, 3 Park Avenue, New York, NY 10016-5990; URL: <http://www.asme.org>.
  - .12 **ASTM International**, 100 Barr Harbor Drive West, Conshohocken, PA 19428-2959; URL: <http://www.astm.org>.
  - .13 **AWCI** - Association of the Wall and Ceiling Industries International, 803 West Broad Street, Suite 600 , Falls Church, VA 22046; URL: <http://www.awci.org>.
  - .14 **AWPA** - American Wire Producer's Association, 801 N Fairfax Street, Suite 211, Alexandria, VA 22314-1757; URL: <http://www.awpa.org>.
  - .15 **AWPA** - American Wood Preservers' Association, P.O. Box 5690, Granbury TX 76049-0690; URL: <http://www.awpa.com>
  - .16 **AWS** - American Welding Society, 550 N.W. LeJeune Road, Miami, FL 33126; URL: <http://www.amweld.org>.
  - .17 **AWWA** - American Water Works Association, 6666 W. Quincy Avenue, Denver, CO 80235; URL: <http://www.awwa.org>.
  - .18 **EIMA** - EIFS Industry Manufacturer's Association, 3000 Corporate Center Drive, Suite 270, Morrow, GA 30260; URL: <http://www.eima.com>.
  - .19 **ISAP** - International Society for Asphalt Paving, 400 Selby Avenue, Suite 1, St. Paul, MN 55102; URL: <http://www.asphalt.org>.
  - .20 **IEEE** - Institute of Electrical and Electronics Engineers, IEE Corporate Office, 3 Park Avenue, 17th Floor, New York, NY 10016-5997; URL: <http://www.ieee.org>
  - .21 **MSS** - Manufacturers Standardization Society of the Valve and Fittings Industry, 127 Park Street, N.E., Vienna, VA 22180-4602; URL: <http://www.mss-hq.com>.
  - .22 **NAAMM** - National Association of Architectural Metal Manufacturers, 8 South Michigan Avenue, Suite 1000, Chicago, IL 60603; URL: <http://www.naamm.org>.
  - .23 **NEMA** - National Electrical Manufacturers Association, 1300 N 17th Street, Suite 1847, Rosslyn, VA 22209; URL: <http://www.nema.org>.
  - .24 **NFPA** - National Fire Protection Association, 1 Batterymarch Park, P.O. Box 9101 Quincy, MA 02269-9101; URL: <http://www.nfpa.org>.
  - .25 **NFSA** - National Fire Sprinkler Association, P.O. Box 1000, Patterson, NY 12563; URL: <http://www.nfsa.org>.
  - .26 **NHLA** - National Hardwood Lumber Association, 6830 Raleigh-La Grange Road, Memphis, TN 38184-0518; URL: <http://www.natlhardwood.org>.
  - .27 **NSPE** - National Society of Professional Engineers, 1420 King Street, Alexandria, VA 22314-2794; URL: <http://www.nspe.org>.

- .28 **PCI** - Prestressed Concrete Institute, 209 W. Jackson Blvd., Suite 500, Chicago, IL 60606-6938; URL: <http://www.pci.org>.
- .29 **PEI** - Porcelain Enamel Institute, PO Box 920220, Norcross, GA 30010; URL: <http://www.porecelainenamel.com>.
- .30 **SSPC** - The Society for Protective Coatings, 40 24th Street, 6th Floor, Pittsburgh, PA 15222-4656; URL: <http://www.sspc.org>.
- .31 **TPI** - Truss Plate Institute, 583 D'Onofrio Drive, Suite 200, Madison, WI 53719; URL: <http://www.tpinst.org>.
- .32 **UL** - Underwriters' Laboratories, 333 Pfingsten Road, Northbrook, IL60062-2096; URL: <http://www.ul.com>.

**END OF SECTION**

## **01 45 00 – Quality Control**

### **1.0 GENERAL**

#### **1.1. RELATED SECTIONS**

- .1 Section 01 21 00 - Allowances.
- .2 Section 01 78 10 – Closeout Submittals and Requirements
- .3 Section 01 79 00 – Demonstration and Training
- .4 This Section describes requirements applicable to all Sections within Divisions 02 to 49.

#### **1.2. REFERENCES**

- .1 **ISO/IEC 17025-2005** - General Requirements for the Competence of Testing and Calibration Laboratories.
- .2 **SCC** (Standards Council of Canada).

#### **1.3. INSPECTION BY AUTHORITY**

- .1 Allow Authorities Having Jurisdiction access to Work. If part of Work is in preparation at locations other than Place of Work, allow access to such Work whenever it is in progress.
- .2 Give timely notice requesting inspection whenever portions of the Work are designated for special tests, inspections or approvals, either when described in the Contract Documents or when required by law in the Place of the Work.
- .3 If Contractor covers or permits to be covered Work that has been designated for special tests, inspections or approvals before such is made, uncover such Work, have inspections or tests satisfactorily completed and make good such Work.

#### **1.4. REVIEW BY CONSULTANT**

- .1 Consultant may order any part of the Work to be reviewed or inspected if Work is suspected to be not in accordance with Contract Documents.
- .2 If, upon review such work is found not in accordance with Contract Documents, correct such Work and pay the cost of additional review and correction.
- .3 If such Work is found in accordance with Contract Documents, The owner will pay the cost of review and replacement.

### **1.5. INDEPENDENT INSPECTION AGENCIES**

- .1 Independent Inspection and Testing Agencies will be engaged by Contractor for the purpose of inspecting and testing portions of Work.
- .2 The Board may, at their discretion, request that the Consultant direct the Contractor to engage independent inspecting and or testing agencies to review or test the Work.
- .3 Allocate Costs for inspections and testing to Section 01 21 00.
- .4 Provide equipment required for executing inspection and testing by appointed agencies.
- .5 Employment of inspection and testing agencies does not relax responsibility to perform Work in accordance with Contract Documents.
- .6 If defects are revealed during inspection and/or testing, the appointed agency will request additional inspection and testing to ascertain the full degree of defect. Correct defects and irregularities as advised by the Consultant at no cost to the Owner. Contractor shall pay costs directly to the inspection agency for retesting and re-inspection.

### **1.6. ACCESS TO WORK**

- .1 Allow inspection and testing agencies access to Work, off site manufacturing and fabrication plants.
- .2 Cooperate to provide reasonable access and facilities for such access.

### **1.7. CONTRACTOR RESPONSIBILITIES**

- .1 Notify appropriate agency minimum 48 hours in advance of requirement for tests, in order that attendance arrangements can be made.
- .2 Submit samples and materials required for testing, as specifically requested in specifications. Submit with reasonable promptness and in an orderly sequence so as not to cause delay in Work.
- .3 Provide labour and facilities to obtain and handle samples and materials on site. Provide sufficient space to store and cure test samples.

### **1.8. DUTIES & AUTHORITY OF TESTING AGENCY**

- .1 Testing agency is expected to do the following:
  - .1 Act in a professional and unprejudiced basis and carry out inspection and testing functions to establish compliance with requirements of Contract Documents.

- 
- .2 Check work as it progresses and prepare reports stating results of tests and conditions of work and state in each report whether specimens tested conform to requirements of Contract Documents, specifically noting deviations.
  - .3 Distribute reports as follows
    - .1 Consultant
    - .2 Owner
    - .3 Contractor
  - .2 Testing agency is not authorized to amend or release any requirements of Contract Documents, nor to approve or accept any portion of work.

### **1.9. REJECTED WORK**

- .1 The Contractor shall remove defective Work, whether result of poor workmanship, use of defective products or damage and whether incorporated in Work or not, which has been rejected by the Consultant as failing to conform to Contract Documents. Replace or re-execute in accordance with Contract Documents.
- .2 Make good other Contractor's work damaged by such removals or replacements promptly.
- .3 If, it is not expedient to correct defective Work or Work not performed in accordance with Contract Documents, the Owner may choose to accept the condition. The difference in value between Work performed and that called for by Contract Documents shall be deducted from the Contract value via Change Order. The amount of this change shall be determined by the Consultant. The Contractor shall warrant the work performed for the time period specified as if it were performed in accordance with the Contract Documents.

### **1.10. TESTING OF EXCAVATION & BACKFILL**

- .1 The Consultant must approve all Sample and fill tests prior to purchase.
- .2 In coordination with the Consultant and Contractor, inspect and test backfill and fill to ensure the degree of compaction specified has been obtained.
- .3 Inspect excavation at required levels in regard to bearing values for footings, foundations and floor slabs.
- .4 Authorization and calculation of extra excavation work, if required, due to unsatisfactory bearing shall be adjusted by Unit Price.

### **1.11. CONCRETE STRENGTH TESTS**

- .1 Review the proposed concrete mix design and check test if considered necessary.

- .2 Obtain representative samples of fresh concrete for each mix design of concrete placed in any one day as directed by the Consultant.
- .3 Make standard slump tests.
- .4 Mould three (3) standard 150mm diameter cylindrical test specimens from each sampling of fresh concrete. Store specimens as per best practice while they are on the site. Cure all cylinders in the laboratory under standard moisture and temperature conditions. Compression test one of the cylinders at 7 days and the remaining two at 28 days after sampling. Each concrete cylinder test report shall contain the specific location of concrete represented by sample, design strength, aggregate size, admixtures used, date, hour and temperature at time of sampling, percentage air content, unit weight and test strength of cylinder.
- .5 When concrete is placed under the conditions of "Cold Weather Requirements" make one additional cylinder; store it in a heated enclosure for 24 hours and then store it on the job site in a place protected from disturbance and off the ground. Compressive test this cylinder 7 days after sampling.
- .6 Determine the air content of air entrained standard weight concrete.
- .7 Determine the air content and unit weight of light weight concrete by the volumetric method.
- .8 Additional testing required because of changes in materials or proportions of the mix requested by the Contractor as well as any extra testing of concrete or materials occasioned by their failure to meet specification requirements or testing of the structure or performance of the structure, including load testing, shall be carried out at the Contractor's expense.

#### **1.12. INSPECTION OF STRUCTURAL STEEL**

- .1 Ensure all steel has mill test reports that comply with the Specification prior to purchase.
- .2 Inspect fabrication of steel in the plant.
- .3 Inspect erection work at site including fit-up, placing, plumbing, levelling, temporary bracing, field cutting and alterations.
- .4 Shop and field inspect welded and bolted connections and painting.
- .5 High strength bolts - the installation and testing of bolts shall conform to the requirements of CSA S16-1969. Check one representative connection in ten by torque testing every bolt, and check each bolt in every connection with a tap of hammer for soundness. Enforce requirements of connection type.

- .6 Examine visually all welded joints for inclusions, porosity, lack of fusion penetration or even contour, undercuts and cracks. Root passes shall be checked for penetration and cracks from the back of the joint. Any suspect welds shall be checked ultrasonically.

### **1.13. INSPECTION OF METAL DECK**

- .1 Check deck for gauge, type and protective coating thickness to ensure compliance with Specification.
- .2 Inspect erection work at the site including anchorage.

### **1.14. INSPECTION AND TESTING OF PAVING**

- .1 Testing shall be carried out in three stages as described below by means of sufficient site visits to ensure satisfactory results but in no case less than three site visits.
- .2 Test within 16 hours from time called to do so by the Contractor, since paving is a critical item at the end of the project.
- .3 Stage One:
  - .1 Visual inspection and compaction tests of subsoil.
- .4 Stage Two:
  - .1 Inspection of granular sub-base (after each layer is placed or after the last layer is placed and compacted).
  - .2 On site density tests.
  - .3 Verify thickness of various levels. (Minimum of 4 checks shall be done on thickness in a paved area of 250m<sup>2</sup> or less, and 1 additional check for each additional 250m<sup>2</sup> or part thereof).
  - .4 Laboratory tests: moisture content and grading of materials.
- .5 Stage Three:
  - .1 Inspection of asphalt installation.
  - .2 Checking of thickness and density of material and checking suitability of equipment used.
- .6 Standard Proctor Test shall be carried out for all projects.
- .7 Further, grain size analysis and Marshall test shall be carried out if visual inspection is not satisfactory or, if there is reason to suspect materials supplied are not acceptable.
- .8 All laboratory tests shall be performed according to A.S.T.M. methods, latest revisions

- .9 Paving Contractor shall obtain from their supplier grading tables of materials used and submit them to the testing laboratory for approval. The paving contractor shall ensure material delivered complies with grading tables.
- .10 Be responsible for all approvals given to the Paving Contractor. At completion of the paving project, inform the Consultant all tests were performed according to the Specifications and the Contractor's performance has been approved.
- .11 The Consultant will not entertain any credits for work either not performed or incorrectly performed by the contractor. If thicknesses or consistencies of sub-base are not as specified, or if asphaltic material is not as specified, then the Contractor shall remove the same at their expense and provide proper specified materials.

### **1.15. BUILDING THERMOGRAPHIC SCAN**

- .1 Upon completion of the Work, the Consultant and/or Owner may arrange for an independent agency to carry out a thermographic scan of the building to determine acceptability of thermal performance of the building envelope.
- .2 Consultant, prior to start of construction work, will designate a sample area of the building to include a portion of exterior wall and roof.
- .3 Consultant will implement a special inspection program for this sample area to be carried out as construction progresses. Contractor shall not cover any completed work until notifying the Consultant and receiving acceptance of completed work. Contractor shall remove and replace any work which is installed in contravention of this requirement.
- .4 Results of a thermographic scan of the entire building will be evaluated and compared to those of the sample area to determine acceptance or rejection of any part of the building envelope.
- .5 Contractor shall carry out remedial work as required to bring the quality of any rejected portion of the building envelope to that of the sample area. Contractor shall pay for costs of any follow-up thermographic scans required to determine acceptability of remedial work. This procedure shall be repeated until all parts of the building envelope have been accepted.

### **1.16. TESTS AND MIX DESIGNS**

- .1 Furnish test results and mix designs as may be requested.
- .2 The cost of tests and mix designs beyond those called for in Contract Documents or beyond those required by law of Place of Work shall be appraised by Consultant and may be authorized as recoverable.

### **1.17. MOCK-UP**

- .1 Prepare mock-up for Work specifically requested in specifications. Include for Work of all Sections required to provide mock-ups.
- .2 Prepare mock-ups for Consultants review with reasonable promptness and in an orderly sequence, so as not to cause any delay in Work.
- .3 Failure to prepare mock-ups in ample time is not considered sufficient reason for an extension of Contract Time and no claim for extension by reason of such default will be allowed.
- .4 If requested, Consultant will assist in preparing a schedule fixing dates for preparation.
- .5 Remove mock-up at conclusion of Work or when acceptable to the Consultant. Repair any damage and clean-up at place of mock-up.
- .6 Approved mock-up may remain as part of Work.

### **1.18. EQUIPMENT AND SYSTEMS**

- .1 Submit adjustment and balancing reports for mechanical and electrical systems to the consultant.
- .2 Refer to Sections 01 78 10 and 01 79 00 for definitive requirements.

**END OF SECTION**

## **01 51 00 – Temporary Utilities**

### **1.0 GENERAL**

#### **1.1. RELATED SECTIONS**

- .1 Section 01 52 00 - Construction Facilities.
- .2 Section 01 53 00 - Temporary Construction.
- .3 This Section describes requirements applicable to all Sections within Divisions 02 to 49.

#### **1.2. INSTALLATION AND REMOVAL**

- .1 Provide temporary utilities controls in order to execute work expeditiously.
- .2 Location of temporary facilities shall be subject to the Consultant's approval.
- .3 Salvage and assist in recycling products for potential reuse wherever possible.
- .4 Remove temporary facilities from the site when directed by the Consultant.

#### **1.3. DEWATERING**

- .1 Provide temporary drainage and pumping facilities to keep excavations and the site free from standing water. Provide necessary pumps (including spare pumps) and temporary drainage for keeping the Work free of water throughout the construction period. Locate sumps away from foundation elements. Control grading around excavation to prevent surface water from draining into excavation and from damaging adjoining property.

#### **1.4. WATER SUPPLY**

- .1 Provide continuous supply of potable water for construction use until such time as permanent municipal water supply is available.
- .2 Hose extensions to be provided by subcontractors requiring them.
- .3 For New Builds, arrange for connection with the appropriate utility company and pay all costs for installation, maintenance, removal, and usage costs until occupancy has been achieved.
- .4 For additions and renovations the contractor can use existing Board service unless noted otherwise.

#### **1.5. TEMPORARY HEATING AND VENTILATION**

- .1 Provide temporary heating required during construction period, including unit rental costs, maintenance.

- 
- .2 Provide temporary heating fuel, if not already available on site, until such time as a permanent natural gas line is installed, and thereafter fuel costs shall be borne by the Board. The Contractor shall provide all connections and piping between the permanent fuel source and the heating appliance(s).
  - .3 Provide temporary heat and ventilation in enclosed areas as required to:
    - .1 Facilitate progress of Work.
    - .2 Protect Work and products against dampness and cold.
    - .3 Prevent moisture condensation on surfaces.
    - .4 Provide ambient temperatures and humidity levels for storage, installation and curing of materials.
    - .5 Provide adequate ventilation to meet health regulations for a safe working environment.
  - .4 Maintain temperatures of minimum:
    - .1 10 degrees C in areas where construction is in progress, until takeover by the Board. Contractor to ensure temporary enclosures remain sealed and penetrations are repaired or closed in a timely fashion.
    - .2 16 degrees C in areas where finishes are in progress.
    - .3 16 degrees C in building once it is enclosed.
    - .4 Refer to other Sections for intermittent heating requirements up to 21 degrees C. Provide insulated tarp enclosures for openings as required to enclose the building after completion of main building shell components and roof.
    - .5 If the Contractor fails to ensure the temporary enclosures remained sealed (including temp doors when not in use) the Consultant and or the Board shall require the contractor to pay 40% of that months usage charge
  - .5 Use forced hot air heaters. Open-flame type heaters or salamanders are not permitted. Ventilate direct fired heating units to the outside.
  - .6 Uniformly distribute heat to avoid hot and cold areas and to prevent excessive drying.
  - .7 Early heating of the building shell will be required to expedite interior finishing to meet the project schedule.
  - .8 Ventilating:
    - .1 Prevent accumulations of dust, fumes, mists, vapours or gases in areas occupied during construction.
    - .2 Provide local exhaust ventilation to prevent harmful accumulation of hazardous substances into the atmosphere of occupied areas.
    - .3 Dispose of exhaust materials in a manner that will not result in harmful exposure to persons.

- .4 Ventilate storage spaces containing hazardous or volatile materials.
- .5 Ventilate temporary sanitary facilities.
- .6 Continue operation of ventilation and exhaust system for time after cessation of work process to assure removal of harmful contaminants.
- .7 Provide minimum 1 air change per hour for enclosed areas receiving architectural finishes.
- .8 Do not allow excessive build-up of moisture inside the building.
- .9 The permanent mechanical systems for the new building, when installed in safe operating conditions, may be used for temporary heating or cooling if approved in writing by the Consultant, without penalty to the warranty.
- .10 Follow the requirements of "Temporary Use of New Permanent Services and Equipment" if the permanent heating system installed under the contract is intended to be used for temporary heating during the construction.
- .11 Provide competent persons to operate and maintain permanent systems for the duration of temporary use period.
- .12 Perform required repairs and maintenance immediately after each inspection. Pay for operating costs. Upon termination of temporary use period, services and equipment shall be inspected, tested, adjusted, fitters replaced, balanced, cleaned and lubricated.
- .13 Permanent services and equipment shall be turned over to the Owner in new and perfect operating condition.
- .14 Use of permanent systems and equipment as temporary facilities shall not affect the guarantee conditions and guarantee period for such systems and equipment. Make due allowance to ensure Owner will receive full benefits of the equipment manufacturer's warranty from the date of Substantial Performance.
- .15 Ensure date of Substantial Performance of the Work and Warranties for heating system do not commence until entire system is in as near original condition as possible and is certified by Consultant.
- .16 Maintain strict supervision of operation of temporary heating and ventilating equipment to:
  - .1 Conform with applicable codes and standards.
  - .2 Enforce safe practices.
  - .3 Prevent abuse of services.
  - .4 Prevent damage to finishes.
  - .5 Vent direct-fired combustion units to outside.
- .17 Be responsible for damage to Work due to failure in providing adequate heat and protection during construction.

## **1.6. TEMPORARY POWER AND LIGHT**

- .1 Provide temporary electrical service and system including lighting and power system for use by all Sections.
- .2 Contractor will provide a source for, and pay the costs of temporary power during construction for temporary lighting and operating of power tools until such time as a permanent source is available.
- .3 Contractor to ensure that the use of power from a source provided by the Board shall not exceed the capacity of the current use required for the operation of any existing facility.
- .4 Install and maintain temporary electrical service and systems in accordance with Construction Safety Association's "Temporary Wiring Standards on Construction Sites", the Ontario Electrical Code and other authorities having jurisdiction.
- .5 Provide at least one temporary panel on each floor with service capacity suitable for construction requirements and to authorities and utilities approval.
- .6 Provide temporary wiring with lighting to all areas of each floor to provide adequate lighting.
  - .1 Lighting levels must be maintained at a minimum of 10 foot candles, or to suit the particular location or operation, whichever is greater.
  - .2 Do not use materials of the temporary service in permanent installation.
  - .3 Increase lighting levels equivalent to the final requirements when finishing operations are underway.
- .7 Extension cords, lights, etc., required by various subcontractors and run from above outlet positions will be supplied and maintained by the party or parties requiring the same.
- .8 Follow requirements of "Temporary Use of New Permanent Services and Equipment" if electrical power and lighting systems installed under the contract are intended to be used for temporary electricity and lighting during the construction.
- .9 Electrical power and lighting systems installed under this contract can be used for construction provided damages are made good and all lamps that have been used for more than two months are replaced with new lamps.
- .10 For New Builds, arrange for connection with the appropriate utility company and pay all costs for installation, maintenance, removal and usage costs until occupancy has been achieved.
- .11 For Additions and renovations the contractor can use existing Board service unless noted otherwise.
- .12 Provide and pay for temporary power for electric cranes and other equipment requiring temporary power in excess of above noted requirements.

**1.7. TEMPORARY COMMUNICATION FACILITIES**

- .1 Contractor to provide and pay for temporary Phone, e-mail and printer hook up, for the duration of contract until completion for use by the contractor.
- .2 The site superintendent is to have email access and a printer on site.

**END OF SECTION**

## **01 53 00 – Temporary Construction Facilities**

### **1.0 GENERAL**

#### **1.1. RELATED SECTIONS**

- .1 Section 01 51 00 - Temporary Utilities.
- .2 Section 01 35 23 – Health and Safety
- .3 This Section describes requirements applicable to all Sections within Divisions 02 to 49.

#### **1.2. INSTALLATION AND REMOVAL**

- .1 Provide temporary construction facilities in order to execute work expeditiously.
- .2 Remove temporary facilities from the site when directed by the Consultant.

#### **1.3. PROTECTION FOR OFF-SITE AND PUBLIC PROPERTY**

- .1 Protect surrounding private and public property from damage during performance of Work.
- .2 Be responsible for damage incurred.

#### **1.4. PROTECTION OF SURROUNDING WORK**

- .1 Provide protection for finished and partially finished Work from damage.
- .2 Provide necessary cover and protection.
- .3 Be responsible for damage incurred due to lack of or improper or inappropriate protection.

#### **1.5. ROOF AND STRUCTURE PROTECTION**

- .1 Ensure no part of Work or existing structures are subjected to a load, which will endanger its safety or will cause permanent deformation.
- .2 The Contractor when indicated by the Board Contact or Consultant shall provide roof protection. Ensure all precautions are taken to avoid liability for roof damage.
- .3 Typical roof protection shall consist of a layer of 1 inch rigid foam insulation set directly on the roof surface and a layer of 19 mm (3/4 inch) plywood in all places under scaffold legs, ladder legs and in areas of foot traffic or falling debris.

#### **1.6. WORK SITE ENCLOSURE & SAFETY BARRIERS**

- .1 Erect and maintain for the duration of the work:

- 
- .1 a minimum 1800mm high chain link fence or self-supporting, heavy duty, interconnected fence panels (commonly referred to as Insta-fence) for a temporary site enclosure (hoarding) completely around perimeter of work site,
  - .2 any temporary posts shall be completely removed by the contractor prior to occupancy,
  - .3 under no circumstance shall t-bar posts be used on Board property,
  - .4 any additional safety devices including full hoarding as required and noted on the drawings, to protect the students, staff, public and private property from injury and damage,
  - .5 any additional requirements as regulated by authorities having jurisdiction, local by-laws and zoning.
- .2 The Contractor is to assume full responsibility for any injury or damage caused due to failure to comply with Paragraph 1 above.
  - .3 Any hazardous conditions identified outside of the main fenced area will be barricaded with a fence complying to the above.
  - .4 Provide lockable truck entrance gate/gates and at least one (1) pedestrian door as directed and conforming to applicable traffic restrictions on adjacent streets. Equip gates with locks and keys with restricted availability, in the project office.
  - .5 Erect and maintain pedestrian walkways including roof and side covers, complete with signs and electrical lighting as required by law.
  - .6 Provide barriers around trees and plants designated to remain.
  - .7 Protect from damage by equipment and construction procedures.

### **1.7. TREE PROTECTION**

- .1 Protect all existing trees to remain from damage during construction period. Make good, at Contractor's expense, trees damaged during construction.
- .2 Confine movement of heavy equipment, storage of same, and storage of materials to a predetermined area. Do not store materials or place equipment over root systems of any existing trees to remain.
- .3 Install fencing or approved equal at limits of drip line of existing trees to remain unless directed otherwise. Where this case is not practical, and only if approved by the Consultant, the trunks shall be protected with an approved tree guard.
- .4 No rigging cables shall be wrapped around or installed in trees. Do not flush concrete trucks or cement mixing machines over root systems or near trees. Flush concrete trucks or cement mixing machines in areas approved by the Consultant.
- .5 Areas where root systems of trees are exposed directly adjacent to a structure will be backfilled with good loam only.

- .6 Whenever excavating is required within branch spread of trees that are to remain, the contractor shall contact the consultant for direction prior to the start of work.
- .7 If any existing tree to remain is injured and does not survive the following year, it will, as determined by the Board, be removed in its entirety and be replaced with a tree of similar size and value, as directed by the Consultant.
- .8 Should the destroyed tree be of such a size or shape that it cannot be feasibly replaced, the Contractor shall compensate the Owner for the minimum sum of five thousand dollars (\$5,000.00) per destroyed tree.

#### **1.8. GUARD RAILS AND BARRIERS**

- .1 Provide secure, rigid guard rails and barricades around deep excavations, open shafts, open stairwells, open edges of floors and roofs.
- .2 Erect and maintain for the duration of the Work, safety devices and barricades including hoarding, as required, to protect the staff, students, public and private property, from injury and damage.
- .3 The Contractor is to ensure that all requirements from authorities having jurisdiction and all requirements from the Owner are met.
- .4 The Contractor is to assume full responsibility for any damage caused due to his failure to comply with paragraph 2 above.
- .5 Hazardous conditions on the exterior shall be fenced.

#### **1.9. WEATHER ENCLOSURES**

- .1 Provide weather-tight closures to unfinished door and window openings, tops of shafts and other openings in floors and roofs.
- .2 Close off floor areas where walls are not finished; seal off other openings; enclose building interior work for temporary heat.
- .3 Design enclosures to withstand wind pressure.

#### **1.10. DUST TIGHT BARRIERS**

- .1 Provide dust tight barriers and screens or partitions to localize dust generating activities, and for protection of workers, finished areas of Work and public.
- .2 Maintain and relocate protection until such work is complete.
- .3 Where required, adjust air handling units to eliminate migration of dust.

### **1.11. SCAFFOLDING**

- .1 Erect scaffolding independent of walls and use in such a manner limiting interference with other work. When not in use, move scaffolding as necessary to permit installation of other work. Construct and maintain scaffolding in a rigid, secure and safe manner. Remove it promptly when no longer required. Protect the surface on which scaffolding is bearing.

### **1.12. SHORING, BRACING, PILING**

- .1 Provide shoring, bracing, piling, sheeting and sheet piling and underpinning required to support soil banks, existing work and property in accordance with Construction Safety Act and other applicable regulations. Maintain shoring until the building is strong enough and sufficiently braced to withstand pressure of backfilling. Make construction aids free of permanent work so they may be removed entirely when no longer required, without damaging the Work. Locate construction aids so adequate room is left for damp-proofing foundation walls, laying substructure drainage and other work.
- .2 Shoring and false work over one tier in height shall be designed and shall bear the stamp of a registered professional engineer, having experience in this field.

### **1.13. HOISTING**

- .1 Provide, operate and maintain services required for moving of workers, materials and equipment. Make financial arrangements with Subcontractors for use thereof.
- .2 Machinery shall be operated by qualified operator.

### **1.14. OVERHEAD LIFTING**

- .1 Any condition requiring the use of a crane or lifting device over a Board structure must follow the requirements of Health and Safety Section 01 35 23, Paragraph 1.15 Overhead Lifting.

### **1.15. ELEVATORS/LIFTS**

- .1 When elevators/lifts are to be used by construction personnel, provide protective coverings for finish surfaces of elevator cabs and entrances.
- .2 Coordinate use of elevator cabs with Consultant and the Board.

### **1.16. USE OF THE WORK**

- .1 Confine work and operations of employees by Contract Documents. Do not unreasonably encumber premises with Products.

- .2 Do not load or permit to load any part of Work with a weight or force that will endanger the Work.

#### **1.17. CONSTRUCTION PARKING**

- .1 Parking will be permitted at rear of site; quantity and location to be identified by the Board.
- .2 Permission to park vehicles on site does not imply any liability or responsibility for safe keeping of vehicles and contents thereof by the School Board.

#### **1.18. ACCESS TO SITE**

- .1 Provide and maintain adequate access to the project site.
- .2 Build and maintain temporary roads where necessary and provide snow removal within the area of work, and access to the work, during the period of Work. The area shall be restored to the satisfaction of the Board at the completion of the project.
- .3 If authorized to use existing roads for access to project site, maintain such roads for duration of Contract and make good damage resulting from Contractors' use of roads.
- .4 Clean roadways and taxi areas where used by Contractor's equipment.
- .5 Access to work area will be through exterior door to Classroom 507, while it is still available.

#### **1.19. SECURITY**

- .1 The Contractor shall ensure the security of the work site, contents, and built structures for the duration of the project.
- .2 The Contractor shall be responsible to provide and pay for security personnel to guard the site and contents of the site after working hours and during holidays as required.
- .3 Notify the Board of the use of security guards or systems.
- .4 The Board shall not be responsible for the loss, theft, or vandalism.

#### **1.20. OFFICES**

- .1 Provide and maintain, until completion of Contract, for Contractor's use, a temporary office, large enough to accommodate site administrative activities and site meetings, complete with light, heat, air conditioning, ventilation, table and chairs. Do not store materials in the office area; keep clean and tidy.
- .2 Provide a clearly marked and fully stocked first-aid case in a readily available location.

- .3 Subcontractors may provide their own offices as necessary. Direct location of these offices.

### **1.21. EQUIPMENT, TOOL AND MATERIALS STORAGE**

- .1 Provide and maintain, in a clean and orderly condition, lockable weatherproof sheds and platforms for storage of tools, equipment and materials.
- .2 Review storage areas on site with the Consultant. Store materials and equipment to ensure preservation of quality of product and fitness for the Work. Store materials and equipment on wooden platforms or other hard, clean surfaces, raised above the ground or in water tight storage sheds of sufficient size for storage of materials and equipment which might be damaged by storage in the open. Locate stored materials and equipment to facilitate prompt inspection.
- .3 Store packaged materials and equipment undamaged, in their original wrappings or containers, with manufacturer's labels and seals intact.
- .4 Locate materials not required to be stored in weatherproof sheds on site in a manner to cause least interference with work activities.
- .5 Storage sheds required by subcontractors shall be provided by them.

### **1.22. SANITARY FACILITIES**

- .1 Provide weatherproof temporary toilet/sanitary facilities for the work force in accordance with governing regulations and ordinances.
- .2 Service temporary toilet/sanitary facilities as required by authorities but not less than weekly.
- .3 Post notices and take such precautions as required by local health authorities.
- .4 The use of existing washroom facilities is not allowed unless specifically approved by the Board. The Contractor will be required to clean and maintain the existing washrooms to Board standards.
- .5 Except where connected to the municipal sewer system, periodically remove wastes from Site.
- .6 Keep toilet/sanitary facilities clean and sanitary and protect from freezing.
- .7 Keep sanitary facilities clean and fully stocked with the necessary supplies at all times.

**END OF SECTION**

## **01 54 00 – Materials and Equipment**

### **1.0 GENERAL**

#### **1.1. RELATED SECTIONS**

- .1 This Section describes requirements applicable to all Sections within Divisions 02 to 49

#### **1.2. PRODUCT AND MATERIAL QUALITY**

- .1 Products, materials, equipment and articles referred to as “Products”; throughout the specifications incorporated in the Work, shall be new, not damaged or defective, and of the best quality, compatible with specifications for the purpose intended. If requested, furnish evidence as to type, source and quality of products provided.
- .2 Defective products will be rejected, regardless of previous inspections. Inspection does not relieve responsibility, but is a precaution against oversight or error. Remove and replace defective products at own expense, and be responsible for delays and expenses caused by rejections.
- .3 Should any dispute arise as to the quality or fitness of products, the decision rests strictly with the Board contact, based upon requirements of the Contract Documents.
- .4 Current Material Safety Data Sheets shall be on file with the successful Contractor and shall be provided to the Board contact upon request, within twenty-four (24) hours.
- .5 Material safety data sheets are not required for products currently WHMIS exempt.

#### **1.3. EQUIPMENT/TOOL MATERIALS STORAGE, HANDLING, AND PROTECTION**

- .1 Handle and store products in a manner to prevent damage, adulterations, deterioration, and soiling, and in accordance with manufacturer’s instructions.
- .2 Store packaged or bundled products in original and undamaged condition, with manufacturer’s seals and labels intact.
- .3 Store products subject to damage from weather in weatherproof enclosures.
- .4 Provide and maintain tools, equipment and materials in a clean and orderly condition. Board tools, ladders, lifts, power cords, flashlights etc. are not to be used.
- .5 Materials are to be stored in a manner to cause the least interference with Work activities.

- .6 The Contractor shall determine with the Board contact, prior to ordering materials, those locations that are suitable for receiving and storage of materials and equipment.
- .7 All materials and equipment shall be kept in a secure area, at Contractor's expense, or removed from the job site when Work is not actually in progress.
- .8 Vehicles, trailers or other similar apparatus may not be stored or parked overnight at site without written authorization from Board contact. Written requests are to be forwarded directly to the Board contact.
- .9 Approval for parking does not imply any liability or responsibility for safe keeping by the Board.
- .10 The Contractor may use the existing electrical and water services, as required, for the Work, and the costs of these services shall be borne by the Board.

#### **1.4. WORKMANSHIP**

- .1 Workmanship shall be the best quality, executed by Workers experienced and skilled in the respective duties for which they are employed. Immediately notify the Consultant if required Work is such as to make it impractical to produce required results.
- .2 Do not employ any unfit persons or anyone unskilled in their required duties.
- .3 Decisions as to the quality or fitness of Workmanship in cases of dispute rest solely with the Board contact, whose decision is final.
- .4 All Contractor personnel are restricted to the job site and necessary access routes. No personnel shall visit other areas or buildings without specific authorization.
- .5 The Contractor shall make their own arrangements for emergency treatment of accidents.
- .6 Any accidents shall be reported immediately to the Board contact.
- .7 The Contractor agrees to hold the Board harmless of any and all liability of every nature and description, which may be suffered through bodily injuries, involving deaths of any persons, by reasons of negligence of the Contractor, his agents, employees, or his Subcontractors.
- .8 The Contractor shall supply constant on-site supervision in the form of a Project Superintendent. The Project Superintendent shall have within their authority to negotiate minor changes regarding scheduling, manpower and equipment.

**1.5. MANUFACTURER'S INSTRUCTIONS**

- .1 Unless otherwise indicated in the specifications, install, apply or erect products in accordance with manufacturer's instructions. Do not rely on labels or enclosures provided with products. Obtain written instructions directly from manufacturers.

**1.6. TOOLS OF THE TRADE**

- .1 The Board will not pay the Awarded Bidder a fee for tools and equipment that are considered "tools of the trade" that are required to perform the work in this Tender or any change orders.

**1.7. EXISTING EQUIPMENT**

- .1 Contractor shall demolish and dispose of all existing equipment specified to be removed and or replaced including obsolete services not being reused. The Board shall have first rights of refusal on all demolished equipment and or parts and the Contractor shall provide a minimum of (5) working days notice prior to disposal of the equipment, parts, or equipment and set aside same in a suitable location to be recovered by Board technicians.

**END OF SECTION**

## **01 61 00 – Product Requirements**

### **1.0 GENERAL**

#### **1.1. RELATED SECTIONS**

- .1 This Section describes requirements applicable to all Sections within Divisions 02 to 49.
- .2 Section 01 31 00 – Project Managing and Coordination

#### **1.2. TERMINOLOGY**

- .1 New: Produced from new materials.
- .2 Renewed: Produced or rejuvenated from an existing material to like-new condition to serve a new or existing service.
- .3 Defective: A condition determined exclusively by the Consultant.

#### **1.3. PRODUCT QUALITY**

- .1 The term 'new' in the following paragraph does not exclude re-manufactured products that have some or all of the materials recycled from other sources. Preference in recycling is for post-consumer recycled materials.
- .2 Products, materials, equipment, parts or assemblies (referred to as Products) incorporated in Work:
- .3 New Product, not damaged or defective, of best quality (compatible with specification requirements) for purpose intended. If requested, provide evidence as to type, source and quality of Products provided.
- .4 Defective Products, whenever identified prior to completion of Work, will be rejected, regardless of previous inspections. Inspection does not relieve responsibility, but is precaution against oversight or error. Remove and replace defective Products at own expense and be responsible for delays and expenses caused by rejection.
- .5 Should any dispute arise as to the quality or fitness of Products, decision rests strictly with Consultant.
- .6 Unless otherwise indicated in specifications, maintain uniformity of manufacture for any particular or like item throughout the building.

#### **1.4. AVAILABILITY**

- .1 Immediately upon receipt of the Board's Purchase Order, review Product delivery requirements and anticipate foreseeable supply delays for any items.

- .2 Immediately upon receipt of the Board's Purchase Order the Contractor shall issue Purchase Orders and or Contracts to all Sub-trades. Provide proof to the Consultant and the Board within 3 days. The Subcontractors shall identify in writing any delivery issues within 14 days of receiving the Contractor's purchase order or contract. The Schedule noted in 01-31 00 1.7.1 shall incorporate all deliveries and installation.
- .3 If delays in supply of Products are foreseeable, notify Consultant of such, in order that substitutions or other remedial action may be authorized in ample time to prevent delay in performance of Work.
- .4 In the event of failure to notify Consultant at commencement of Work and should it subsequently appear that Work may be delayed for such reason, Consultant reserves the right to substitute more readily available Products of similar character, at no increase in Contract Price or Contract Time.

#### **1.5. STORAGE AND PROTECTION**

- .1 Store and protect Products in accordance with manufacturers' written instructions.
- .2 Store with seals and labels intact and legible.
- .3 Store sensitive Products in weather tight, climate controlled, enclosures in an environment favourable to Product.
- .4 For exterior storage of fabricated Products, place on sloped supports above ground.
- .5 Cover Products subject to deterioration with impervious sheet covering. Provide ventilation to prevent condensation and degradation of Products.
- .6 Store loose granular materials on solid flat surfaces in a well-drained area. Prevent mixing with foreign matter.
- .7 Provide equipment and personnel to store Products by methods to prevent soiling, disfigurement, or damage.
- .8 Arrange storage of Products to permit access for inspection. Periodically inspect to verify Products are undamaged and are maintained in acceptable condition.

#### **1.6. TRANSPORTATION AND HANDLING**

- .1 Transport and handle Products in accordance with manufacturer's written instructions.
- .2 Promptly inspect shipments to ensure that Products comply with requirements, quantities are correct, and Products are undamaged.
- .3 Provide equipment and personnel to handle Products by methods to prevent soiling, disfigurement, or damage.
- .4 Suitably pack, crate and protect products during transportation to site to preserve their quality and fitness for the purpose intended.

- .5 Store products in original, undamaged condition with manufacturer's labels and seals intact until they are being incorporated into completed work.
- .6 Protect materials from damage by extreme temperatures or exposure to the weather.

### **1.7. EXISTING UTILITIES**

- .1 When breaking into or connecting to existing services or utilities, execute Work at times directed by local governing authorities, with minimum disturbance to the owner.
- .2 Protect, relocate or maintain existing active services. When services are encountered, cap off in a manner approved by authority having jurisdiction. Stake and record location of capped service.

### **1.8. MANUFACTURER'S WRITTEN INSTRUCTIONS**

- .1 Unless otherwise indicated in specifications, install or erect Products to manufacturer's written instructions. Do not rely on labels or enclosures provided with Products. Obtain written instructions directly from manufacturers.
- .2 Notify Consultant in writing, of conflicts between specifications and manufacturer's instructions, so that Consultant may establish course of action.
- .3 Improper installation or erection of Products, due to failure in complying with these requirements, authorizes Consultant to require removal and reinstallation at no increase in Contract Price or Contract Time.

### **1.9. QUALITY OF WORK**

- .1 Ensure Quality of Work is of highest standard, executed by workers experienced and skilled in respective duties for which they are employed. Immediately notify Consultant if required Work is such as to make it impractical to produce required results.
- .2 Do not employ anyone unskilled in their required duties. Consultant and or Board reserves right to require dismissal from site any workers deemed incompetent or careless.
- .3 Decisions as to standard or fitness of Quality of Work in cases of dispute rest solely with Consultant, whose decision is final.
- .4 Products, materials, systems and equipment shall be applied, installed, connected, erected, used, cleaned and conditioned in accordance with the applicable manufacturer's printed directions.

- .5 Where specified requirements are in conflict with manufacturer's written directions, follow manufacturer's directions. Where specified requirements are more stringent than manufacturer's directions, comply with specified requirements.

#### **1.10. COORDINATION**

- .1 Ensure cooperation of workers in laying out Work. Maintain efficient and continuous supervision.
- .2 Be responsible for coordination and placement of openings, sleeves and accessories.
- .3 Contractor is responsible to ensure suppliers or distributors of materials specified or alternatives accepted, which he intends to use, have materials with original schedule, and similarly it shall be the responsibility of all subcontractors and suppliers to so inform the Contractor.
- .4 Contractor shall contact Consultant immediately upon receipt of information indicating materials or items, will not be available on time, in accordance with the latest approved schedule, and similarly it shall be the responsibility of all subcontractors and suppliers to so inform the Contractor.
- .5 The above, in no way releases the Contractor, or their subcontractors and suppliers of their responsibility for ensuring timely ordering of materials and items required, including the necessary expediting, to complete the Work as scheduled in accordance with the Contract Documents including temp accommodations and or materials to ensure occupancy date is achieved.

#### **1.11. CONCEALMENT**

- .1 In finished areas, conceal pipes, ducts and wiring in floors, walls and ceilings, except where indicated otherwise.
- .2 Before installation, inform the Consultant if there is interference. Install as directed by the Consultant at no additional cost to the Board.

#### **1.12. REMEDIAL WORK**

- .1 Perform remedial work required to repair or replace parts or portions of Work identified as defective or unacceptable. Coordinate adjacent affected Work as required.
- .2 Perform remedial work by specialists familiar with materials affected. Perform in a manner to neither damage nor put at risk any portion of Work.

#### **1.13. LOCATION OF FIXTURES**

- .1 Inform Consultant of conflicting installation. Install as directed.

**1.14. FASTENINGS - EQUIPMENT**

- .1 Use fastenings of standard commercial sizes and patterns with material and finish suitable for service.
- .2 Use heavy hexagon heads, semi-finished unless otherwise specified. Use Type 304 or 316 stainless steel for exterior areas.
- .3 Bolts may not project more than one diameter beyond nuts.
- .4 Use plain type washers on equipment, sheet metal and soft gasket lock type washers where vibrations occur. Use resilient washers with stainless steel.

**1.15. PROTECTION OF WORK IN PROGRESS**

- .1 Prevent overloading of any part of the Project.
- .2 Do not cut, drill or sleeve any load bearing structural member, unless specifically indicated, without written approval of the Consultant.

**END OF SECTION**

## **01 70 00 – Examination and Preparation**

### **1.0 GENERAL**

#### **1.1. RELATED SECTIONS**

- .1 This Section describes requirements applicable to all Sections within Divisions 02 to 49.

#### **1.2. REFERENCES**

- .1 Owner's identification of existing survey control points and property limits.

#### **1.3. SUBMITTALS**

- .1 NOT APPLICABLE.

#### **1.4. QUALIFICATIONS OF SURVEYOR**

- .1 NOT APPLICABLE.

#### **1.5. SURVEY REFERENCE POINTS**

- .1 NOT APPLICABLE.

#### **1.6. SURVEY REQUIREMENTS**

- .1 NOT APPLICABLE.

#### **1.7. SUBSURFACE CONDITIONS**

- .1 Promptly notify Consultant in writing if discovered surface or subsurface conditions at Place of Work differ materially from those indicated in Contract Documents.
- .2 Advise the Consultant of a reasonable assumption of probable conditions when determined.
- .3 After prompt investigation, should Consultant determine that conditions do differ materially, instructions will be issued for changes in Work.

#### **1.8. EXAMINATION**

- .1 The Contractor is expected to be totally familiar with site conditions and shall assume full responsibility for the cost involved in repairing any damage to the building, site and services, city property, adjacent buildings, etc., during general construction, regardless of the extent of the damage.

- .2 Inspect existing conditions, including elements or adjacent Work subject to irregularities, damage, movement, including Work during cutting and patching.
- .3 The Contractor shall provide all equipment necessary to make a full and detailed site evaluation. This shall include but not be limited to ladders, flashlights and hand tools.
- .4 The Contractor expressly agrees that conditions above existing suspended acoustic ceilings, but below fixed structure, unless obscured by an additional ceiling above, shall be considered exposed conditions for the purposes of making findings under the provisions of the Contract. There shall be no claims for extra costs for extra Work in these areas.
- .5 After uncovering, inspect conditions affecting performance of the Work.
- .6 Beginning of cutting or patching means acceptance of existing conditions.

#### **1.9. PREPARATION**

- .1 Provide supports to assure structural integrity of surroundings; provide devices and methods to protect other portions of the project from damage.
- .2 Provide protection from elements for areas which may be exposed by uncovering work; maintain excavations free of water.

#### **1.10. EXISTING SERVICES**

- .1 Before commencing work, establish location and extent of service lines in the area of Work and notify the Consultant of findings.
- .2 Remove abandoned service lines running through existing and new structures. Cap or seal lines at cut-off points as directed by the Consultant.

#### **1.11. LOCATION OF EQUIPMENT AND FIXTURES**

- .1 Inform Consultant of conflicting installations, install as directed.
- .2 Locate equipment, fixtures and distribution systems to provide minimum interference and maximum usable space and in accordance with manufacturer's recommendations for safety, access and maintenance.
- .3 Inform Consultant of impending installation and obtain approval for actual location.
- .4 Submit field drawings to indicate relative position of various services and equipment when required by Consultant.

**1.12. SURVEY RECORD**

- .1 Maintain a complete, accurate log of control and survey work as it progresses.
- .2 On completion of foundations and major site improvements, prepare a certified survey showing dimensions, locations, angles and elevations of Work.
- .3 Record locations of maintained, re-routed and abandoned service lines.

**END OF SECTION**

## **01 73 30 – Execution and Cutting and Patching**

### **1.0 GENERAL**

#### **1.1. RELATED SECTIONS**

- .1 Section 01 32 00 - Construction Progress Documentation: Submittals and scheduling.
- .2 Section 01 61 00 - Product Requirements.
- .3 Section 01 70 00 – Examination and Preparation
- .4 Individual Product Specification Sections:
  - .1 Cutting and patching incidental to work of the Section.
  - .2 Advance notification to other sections of openings required in Work of those Sections.

#### **1.2. SUBMITTALS**

- .1 Submit written request in advance of cutting or alteration which affects:
  - .1 Structural integrity of any element of Project.
  - .2 Integrity of weather exposed or moisture resistant element.
  - .3 Efficiency, maintenance, or safety of any operational element.
  - .4 Visual qualities of sight exposed elements.
  - .5 Work of Owner or separate contractor.
- .2 Include in request:
  - .1 Identification of Project.
  - .2 Location and description of affected Work.
  - .3 Necessity for cutting or alteration.
  - .4 Description of proposed Work and Products to be used.
  - .5 Alternatives to cutting and patching.
  - .6 Effect on work of Owner or separate contractor.
  - .7 Written permission of affected separate contractor.
  - .8 Date and time work will be executed.

#### **1.3. TOLERANCES**

- .1 Monitor fabrication and installation tolerance control of Products to produce acceptable Work.
- .2 Do not permit tolerances to accumulate beyond effective or practical limits.
- .3 Comply with manufacturers' tolerances. In case of conflict between manufacturers' tolerances and Contract Documents, request clarification from the Consultant before proceeding.

- .4 Adjust Products to appropriate dimensions; position and confirm tolerance acceptability, before permanently securing Products in place.

## **2.0 PRODUCTS**

### **2.1. MATERIALS**

- .1 Primary Products: Those required for original installation.
- .2 Product Substitution: For any proposed change in materials, submit a request for substitution described in Section 01 33 00.

## **3.0 EXECUTION**

### **3.1. EXAMINATION**

- .1 Examine existing conditions prior to commencing Work, including elements subject to damage or movement during cutting and patching.
- .2 After uncovering existing Work, assess conditions affecting performance of work.
- .3 Beginning of cutting or patching means acceptance of existing conditions.

### **3.2. PREPARATION**

- .1 Provide temporary supports to ensure structural integrity of the Work. Provide devices and methods to protect other portions of the Project from damage.
- .2 Provide protection from elements for areas which may be exposed by uncovering work.
- .3 Maintain excavations free of water.

### **3.3. CUTTING**

- .1 Execute cutting and fitting as needed to complete the Work. Prior to any cutting and or coring of concrete floors the contractor shall confirm the area is free of services or rebar. Notify the Consultant of any interferences.
- .2 Uncover work to install improperly sequenced work.
- .3 Remove and replace defective or non-conforming work.
- .4 Remove samples of installed work for testing for Hazardous materials.
- .5 Provide openings in the Work for penetration of mechanical and electrical work.
- .6 Employ experienced installer to perform cutting for weather exposed and moisture resistant elements, and sight exposed surfaces.
- .7 Cut rigid materials using a masonry saw or core drill. Pneumatic tools are not allowed without prior approval.

- .8 Do all cutting, patching, and making good, to leave a finished condition and to make the several parts of the work come together properly. Coordinate work to keep cutting and patching to a minimum.
- .9 Make cuts with clean, true, smooth edges. Fit unit to tolerance established by test standard practice for applicable work. Make patches invisible in the final assembly.
- .10 Cutting shall be done in a manner to keep patching to minimum. Obtain Consultant's approval of method to be used to conceal new mechanical and electrical services before beginning cutting. Chasing of concrete surfaces is not permitted.
- .11 Cutting or coring of any structural concrete is to be reviewed and approved by the Consultant.
- .12 Do not endanger any work by cutting, digging or otherwise altering, and do not cut nor alter any load bearing element without written authorization by Consultant. Provide bracing, shoring and temporary supports as required to keep construction safely supported at all times
- .13 Any cost caused by omission or ill-timed work shall be borne by the party responsible thereof.
- .14 Regardless of which Section of work is responsible for any portion of cutting and patching, in each case tradesmen qualified in work being cut and patched shall be employed to ensure it is correctly done.

### **3.4. PATCHING**

- .1 Execute patching to complement adjacent Work.
- .2 Fit Products together to integrate with other Work.
- .3 Execute work by methods to avoid damage to other Work, and which will provide appropriate surfaces to receive patching and finishing.
- .4 Employ original installer to perform patching for weather exposed and moisture resistant elements, and sight-exposed surfaces.
- .5 Restore work with new Products in accordance with requirements of Contract Documents.
- .6 Fit work with adequate support to pipes, sleeves, ducts, conduit, and other penetrations through surfaces.
- .7 At penetrations of fire rated walls, partitions, ceiling, or floor construction, completely seal voids with firestop material.
- .8 Refinish surfaces to match adjacent finish. For continuous surfaces, refinish to the nearest intersection or natural break. For an assembly, refinish the entire unit.
- .9 Complete and tightly fit all construction to pipes, ducts and conduits which pass through construction to completely prevent the passage of air.

- .10 Patching and making good shall be done by trade specialists in material to be treated, and shall be made undetectable in finished work when viewed from a distance of 1.5m under normal lighting.

**END OF SECTION**

## **01 74 00 – Cleaning and Waste Management**

### **1.0 GENERAL**

#### **1.1. RELATED SECTIONS**

- .1 Common Work by All Trades
- .2 This Section describes requirements applicable to all Sections within Divisions 02 to 49.
- .3 Conduct cleaning and disposal operations to comply with local ordinances and environmental protection legislation.
- .4 Store volatile wastes in covered metal containers, and remove them from premises at the end of each working day.
- .5 Provide adequate ventilation during use of volatile or noxious substances. Use of building ventilation systems is not permitted for this purpose.

### **2.0 PRODUCTS**

#### **2.1. CLEANING PRODUCTS**

- .1 Cleaning Agents and Materials: Low VOC content wherever possible. The Consultant and the Board shall be notified prior to use of any exception.

### **3.0 EXECUTION**

#### **3.1. CLEANING DURING CONSTRUCTION**

- .1 Maintain the Work in tidy condition, free from accumulation of waste products and debris, other than that caused by the Owner or other Contractors.
- .2 Remove waste material and debris from the work areas and deposit in a waste container at the end of each working day.
- .3 Vacuum clean interior areas prior to the start of finishing work. Maintain areas free of dust and other contaminants during finishing operations.
- .4 Individual Subcontractors are responsible for the daily clean-up and removal of debris related to, or generated by, their own work. The overall responsibility for project cleanliness rests with the Contractor.
- .5 The Contractor shall be responsible for snow removal within the construction area.
- .6 Make arrangements with and obtain permits from authorities having jurisdiction for disposal of waste and debris.
- .7 Wherever possible recycle materials

- .8 Containers:
  - .1 Provide adequate number and sizes of on-site garbage and recycling containers within designated work site as required for collection of waste materials and debris on a daily basis.
  - .2 Provide additional waste containers when the extent of work warrants.
  - .3 Provide and use clearly marked, separate bins for recycling.
- .9 Dispose of waste materials and debris at registered waste disposal and recycling facility.
- .10 Remove oily rags, waste and other hazardous substances from premises at close of each day, or more often when required.
- .11 Schedule cleaning operations so that resulting dust, debris and other contaminants will not fall on wet, newly painted surfaces nor contaminate building systems.

### **3.2. WASTE MANAGEMENT**

- .1 Audit, separate and dispose of construction waste generated by new construction or by demolition of existing structures in whole or in part, in accordance with Ontario Regulations 102/94 and 103/94 made under the Environmental Protection Act.
- .2 Containers:
  - .1 Provide adequate number and sizes of on-site garbage and recycling containers within designated work site as required for collection of waste materials and debris on a daily basis.
  - .2 Provide additional waste containers when the extent of work warrants.
  - .3 Provide and use clearly marked, separate bins for recycling.
- .3 Fires, and burning of rubbish or waste on site is strictly prohibited.
- .4 Burying of rubbish or waste materials on site is strictly prohibited.
- .5 Disposal of waste or volatile materials such as mineral spirits, oil, gasoline or paint thinner into ground, waterways, or sewer systems is prohibited.
- .6 Empty waste containers on a regular basis to prevent contamination of site and adjacent properties by wind-blown dust or debris

### **3.3. PREPARATION FOR FINAL CLEANING**

- .1 Prior to final cleaning the General Contractor shall:
  - .1 remove all surplus products, tools, construction machinery and equipment not required for the performance of remaining work, and thereafter remove any remaining materials, equipment, waste and debris,
  - .2 replace all filters installed on any equipment in operation in the area of work,

- .3 remove all paint spots or overspray from all affected surfaces, and

### **3.4. FINAL CLEANING PRIOR TO ACCEPTANCE: INTERIOR**

- .1 Prior to applying for Substantial Performance of the Work, or, prior to Owner occupancy of the building or portion of the building affected by the Work, whichever comes first, conduct full and complete final cleaning operations for the areas to be occupied.
- .2 Final cleaning operations shall be performed by an experienced professional cleaning company, possessing equipment and personnel sufficient to perform full building cleaning operations. Contractors “broom cleaning” is not acceptable as a “Final Clean”. The cleaning contractor shall:
  - .1 clean interiors of all millwork and surfaces of any furniture and equipment present,
  - .2 use only cleaning materials recommended by the manufacturer of the surface to be cleaned,
  - .3 remove all stains, spots, scuff marks, dirt, dust, remaining labels, adhesives or other surface imperfections,
  - .4 clean and polish all glass and mirrors and remove remaining manufacturer's and safety "X" labels,
  - .5 clean and polish all finished metal surfaces such as enamelled or stainless steel, chrome, aluminum, brass, and bronze,
  - .6 clean and polish all vitreous surfaces such as plumbing fixtures, ceramic tile, porcelain enamel, or other such materials,
  - .7 clean all ceramic tile surfaces in accordance with the manufacturer's instructions,
  - .8 vacuum, clean and dust behind grilles, louvres and screens,
  - .9 steam clean all unprotected carpets immediately prior occupancy by Owner, and
  - .10 clean all equipment and fixtures to a sanitary condition.
- .3 For any areas to be occupied after the owner's initial occupancy, provide full cleaning operations as outlined above prior to turning over to Owner,
- .4 The Board's supplies and equipment must not be used for any cleaning operations including, but not limited to: garbage cans, mops, brooms, rags, ladders, chemicals etc.

**3.5. FINAL CLEANING PRIOR TO ACCEPTANCE: EXTERIOR**

- .1 For areas affected by construction final exterior cleaning operations shall be performed by the General Contractor or competent Subcontractor. Contractor's "broom cleaning" only is not acceptable.
- .2 Final exterior cleaning shall include:
  - .1 broom clean and wash exterior walkways, steps, and surfaces; rake clean other surfaces of grounds,
  - .2 remove dirt and other disfiguration from exterior surfaces,
  - .3 sweep and wash clean paved areas,
  - .4 replace filters of mechanical equipment for all equipment that was in use during construction,
  - .5 clean all roofs, gutters, downspouts, areaways, drywells, and drainage systems,
  - .6 remove debris and surplus materials from crawl areas and other accessible concealed spaces.
  - .7 remove overspray

**END OF SECTION**

## **01 78 10 – Closeout Submittals and Requirements**

### **1.0 GENERAL**

#### **1.1. RELATED SECTIONS**

- .1 Section 01 78 10 – WRDSB Warranty Card, Appendix 00 41 13A

#### **1.2. TAKE-OVER PROCEDURES**

- .1 Take over procedures will be in strict accordance with the requirements as set out in this Section.

#### **1.3. SUBSTANTIAL PERFORMANCE**

- .1 Prior to requesting a Substantial Performance deficiency inspection submit 2 hard copies, 1 digital copy of the Operating and Maintenance Manuals for Consultants approval.
- .2 Application for Substantial Performance must include:
  - .1 One (1) electronic copy of inspection and acceptance certificates required from regulatory agencies, including but not limited to.
    - .1 Certificates of Approval of the Work by the local Building Department.
    - .2 Electrical Inspection Certificate of Inspection.
    - .3 Fire Alarm Verification Certificate.
- .3 Advise Consultant in writing, when the project has been substantially completed. If Consultant agrees this stage has been reached, the Consultant shall prepare a complete list of deficiencies and submit copies of this list to Contractor and the Board.

#### **1.4. COMMENCEMENT OF LIEN PERIODS**

- .1 The date of publication of the Certificate of Substantial Performance of the Work, provided to the contractor by the Consultant, shall be the date for commencement of the lien period.

#### **1.5. TOTAL PERFORMANCE**

- .1 Prior to requesting a final inspection submit written certificate that the following have been performed:
  - .1 Work has been completed and inspected for compliance with Contract Documents and is ready for final inspection
  - .2 Defects have been corrected and deficiencies have been completed.

- 
- .3 Equipment and systems have been tested and are fully operational. Submit two copies of the balancing reports
  - .4 Certificates required by the contractor have been submitted.
  - .5 Operation of systems have been demonstrated to Owner's personnel.
  - .6 Submit Record drawings.
  - .7 Submit maintenance materials.
  - .8 Provide certified site survey
- .2 When items noted above are completed, request final inspection of Work by consultant, and building inspector. If Work is deemed incomplete by Consultant, complete outstanding items and request re-inspection.

**1.6. PAYMENT OF SUBSTANTIAL PERFORMANCE HOLDBACK**

- .1 Prior to the release of lien holdback provide one copy of the following by the Contractor and each subcontractor:
  - .1 Statutory Declaration or Declaration of Last supply
  - .2 Workplace Safety and Insurance Board "Certificate of Clearance".
- .2 The Contractor shall submit an application for payment of the holdback amount.
- .3 After the receipt of an application for payment which will include a Statutory Declaration and WSIB Clearance from the, the Consultant will issue a certificate for payment of the holdback amount.

**1.7. FINAL PAYMENT**

- .1 When the Contractor considers final deficiencies and defects have been corrected and it appears requirements of Contract have been completed, make application for final payment.
- .2 When the Consultant finds the Contractor's application for final payment valid, the Consultant will issue a final certificate of payment
- .3 The Board reserves the right to charge the Contractor for school access card(s) that have not been returned.
- .4 The cost to reprogram or replace the card(s) access system is estimated at \$50.00 (fifty dollars) for each card issued, \$30.00 (thirty dollars) for each keybox key, plus \$35.00 (thirty five dollars) administration fee.

**1.8. CLOSEOUT SUBMITTALS**

- .1 Prepare instructions and data using personnel experienced in maintenance and operation of described products and submit them to the Consultant for review.
- .2 Copy will be returned to the contractor with the Consultant's comments.

- 
- .3 Revise content of documents as required prior to final submission.
  - .4 Two (2) weeks prior to Substantial Performance of the Work, submit to the Consultant, the final copies of operating and maintenance manuals.
  - .5 Ensure spare parts, maintenance materials and special tools provided are new, undamaged or defective, and of same quality and manufacture as products provided in Work.
  - .6 If requested, furnish evidence as to type, source and quality of products provided.
  - .7 Defective products will be rejected, regardless of previous inspections. Replace products at own expense.
  - .8 Pay costs of transportation.

### **1.9. OPERATION AND MAINTENANCE MANUAL FORMAT**

- .1 Provide two copies of operating and maintenance data, prepared on 215 X 280mm sheets in printed or typewritten form, contained in 3-ring binders with soft vinyl covers for materials and equipment which require special maintenance or operating procedures.
- .2 When multiple binders are used, correlate data into related consistent groupings. Identify contents of each binder at the front of each volume.
- .3 Cover: Identify each binder with type or printed title 'Project Record Documents'; list title of project and identify subject matter of contents.
- .4 Arrange content by the divisions of the specifications under Section numbers and sequence of Table of Contents.
- .5 Provide tabbed fly leaf for each separate product and system, with typed description of product and major component parts of equipment.
- .6 Include the following in each manual:
  - .1 Complete list of subcontractors and suppliers, their addresses and telephone numbers. Provide 24 hour emergency telephone numbers for such subcontractors as Plumbing, Electrical, Sprinklers, Fire System, Heating, etc.
  - .2 Specified warranties for contractor, each subcontractor and supplier.
  - .3 WRDSB Project Asset and Warranty Card, Appendix 00 41 13A
  - .4 Copy of finish hardware list, complete with all amendments and revisions and lock manufacturer's descriptive and service literature.
  - .5 Schedule of paints and coatings. Include sufficient explanation to fully identify each surface with the applicable paint or coating used. Enclose a copy of the colour schedule.
  - .6 Maintenance instructions for finished surfaces.
  - .7 Brochures, cuts of equipment and fixtures.

- 
- .8 Operating and maintenance instructions for equipment.
  - .9 Submit copies of letters from manufacturers of equipment and systems indicating their technical representatives have inspected and tested systems and are satisfied with methods of installation, connection and operations. These letters shall state names of persons present at testing, methods used and list of functions performed.
  - .10 Submit one complete set of reviewed shop drawings of architectural, structural, mechanical and electrical items, folded to 215 x 280mm size, contained in heavy duty manila envelopes, numbered and labelled. Follow specification format with no more than one Section per envelope, hard copy and PDF.
  - .11 Relevant certificates issued by authorities having jurisdiction
  - .12 Computer disc or flash drive with all the above documentation in PDF format

#### **1.10. RECORDING ACTUAL SITE CONDITIONS**

- .1 Record information on a set of black line opaque drawings, and within the Project Manual.
- .2 Annotate with coloured felt tip marking pens, maintaining separate colours for each major system, for recording changed information.
- .3 Record information concurrently with construction progress. Do not conceal Work of the Project until required information is accurately recorded.
- .4 Contract drawings and shop drawings: legibly mark each item to record actual construction, including:
  - .1 Measured depths of elements of foundation in relation to finish first floor datum.
  - .2 Measured horizontal and vertical locations of underground utilities and appurtenances, referenced to permanent surface improvements.
  - .3 Measured locations of internal utilities and appurtenances, referenced to visible and accessible features of construction.
  - .4 Field changes of dimension and detail.
  - .5 Changes made by change orders.
  - .6 Details not on original Contract Drawings.
  - .7 References to related shop drawings and modifications.
- .5 Specifications: legibly mark each item to record actual construction, including:
  - .1 Manufacturer, trade name, and catalogue number of each product actually installed, particularly optional items and substitute items.
  - .2 Changes made by Addenda and change orders.

- .6 Other Documents: Maintain warranties, test reports and samples required by individual specifications sections.

#### **1.11. RECORD (AS-BUILT) DOCUMENTS AND SAMPLES**

- .1 Store AS-BUILT documents and samples in the field office apart from documents used for construction. Provide files, racks, and secure storage.
- .2 Label AS-BUILT documents and file in accordance with section number listings in List of Contents of the Project Manual. Label each document AS-BUILT DOCUMENTS in neat, large, printed letters.
- .3 Maintain AS-BUILT documents in clean, dry and legible condition. Do not use as-built documents for construction purposes.
- .4 Keep as-built documents and samples available for inspection by the Consultant.

#### **1.12. RECORD DRAWINGS**

- .1 Prior to Substantial Performance of the Work, update the marked up information from the AS-BUILT documents to a master set of drawing.
- .2 Submit one set of completed AS-BUILT documents to the Consultant for review.
- .3 Documents will be returned to the contractor with the Consultant's comments.
- .4 Revise content of documents as required prior to final submission.
- .5 After the review is completed resubmit to the Consultant for Consultant to produce electronic record drawings for the owner to use.

#### **1.13. SPARE PARTS**

- .1 Provide spare parts, in quantities specified in individual specification sections.
- .2 Provide items of same manufacture and quality as items in Work.
- .3 Receive and catalogue all items. Submit inventory listing to Consultant. Include approved listings in the Maintenance Manual.
- .4 Obtain receipt for delivered products and submit prior to final payment.

#### **1.14. REPLACEMENT (MAINTENANCE) MATERIALS**

- .1 Deliver to site, unload and store where directed, replacement (maintenance) materials as required elsewhere in these Specifications. Obtain a signed receipt from the Owner's Representative for delivered materials and include a copy of receipt in Operation and Maintenance manuals.
- .2 Package materials so they are protected from damage and loss of essential properties.
- .3 Label packaged materials for proper identification of contents.

**1.15. SPECIAL TOOLS**

- .1 Provide special tools, in quantities specified in the individual specification section.
- .2 Provide items with tags identifying their associated function and equipment.
- .3 Receive and catalogue all items. Submit inventory listing to Consultant. Include approved listings in Maintenance Manual

**1.16. FINAL SITE SURVEY**

- .1 NOT APPLICABLE.

**1.17. WARRANTIES AND BONDS**

- .1 Separate each warranty or bond with index tab sheets keyed to Table of Contents listing.
- .2 List subcontractor, supplier, and manufacturer, with name, address, and telephone number of responsible principal.
- .3 Except for items put into use with Owner's permission, leave the date of beginning of time of warranty until the Date of Substantial Performance is determined. The date of Substantial Performance of the Work shall be the date for commencement of the warranty period.
- .4 Verify that documents are in proper form, contain full information, and are notarized.
- .5 Co-execute submittals when required.
- .6 Retain warranties and bonds until time specified for submittals.

**END OF SECTION**

## **01 78 40 – Maintenance Requirements**

### **1.0 GENERAL**

#### **1.1. SECTION INCLUDES**

- .1 Equipment and systems.
- .2 Materials and finishes.
- .3 Spare parts
- .4 Maintenance manuals.
- .5 Special tools.
- .6 Storage, handling and protection.
- .7 This Section describes requirements applicable to all Sections within Divisions 02 to 49.

#### **1.2. RELATED SECTIONS**

- .1 Section 01 45 00 - Quality Control.
- .2 Section 01 78 40 – Maintenance Requirements.
- .3 This Section describes requirements applicable to all Sections within Divisions 02 to 49.

#### **1.3. EQUIPMENT AND SYSTEMS**

- .1 Each Item of Equipment and Each System: include description of unit or system, and component parts. Give function, normal operation characteristics, and limiting conditions. Include performance curves, with engineering data and tests, and complete
- .2 Panel board circuit directories: provide electrical service characteristics, controls, and communications.
- .3 Include installed colour coded wiring diagrams.
- .4 Operating Procedures: include start-up, break-in, and routine normal operating instructions and sequences. Include regulation, control, stopping, shut-down, and emergency instructions. Include summer, winter, and any special operating instructions.
- .5 Maintenance Requirements: include routine procedures and guide for trouble-shooting; disassembly, repair, and reassembly instructions; and alignment, adjusting, balancing, and checking instructions.
- .6 Provide servicing and lubrication schedule, and list of lubricants required.
- .7 Include manufacturer's printed operation and maintenance instructions.

- .8 Include sequence of operation by controls manufacturer.
- .9 Provide original manufacturer's parts list, illustrations, assembly drawings, and diagrams required for maintenance.
- .10 Provide installed control diagrams by controls manufacturer.
- .11 Provide coordination Drawings, with installed colour coded piping diagrams.
- .12 Provide charts of valve tag numbers, with location and function of each valve, keyed to flow and control diagrams.
- .13 Provide a list of original manufacturer's spare parts, current prices, and recommended quantities to be maintained in storage.
- .14 Include test and balancing reports as specified in Section 01 45 00.
- .15 Additional requirements: As specified in individual specification sections.

## **2.0 PRODUCTS**

### **2.1. MATERIALS AND FINISH**

- .1 Building Products, Applied Materials, and Finishes: include product data, with catalogue number, size, composition, and colour and texture designations.
- .2 Instructions for cleaning agents and methods, precautions against detrimental agents and methods, and recommended schedule for cleaning and maintenance.
- .3 Moisture-protection and Weather-exposed Products: include manufacturer's recommendations for cleaning agents and methods, precautions against detrimental agents and methods, and recommended schedule for cleaning and maintenance.
- .4 Building Envelope: include copies of drawings of building envelope components, illustrating the interface with similar or dissimilar items to provide an effective air, vapour and thermal barrier between indoor and outdoor environments. Include an outline of requirements for regular inspections and for regular maintenance to ensure that on-going performance of the building envelope will meet the initial building envelope criteria.
- .5 Additional Requirements: as specified in individual specifications sections.

### **2.2. SPARE PARTS**

- .1 Provide spare parts, in quantities specified in individual specification sections.
- .2 Provide items of same manufacture and quality as items in Work.
- .3 Receive and catalogue all items. Submit inventory listing to Consultant. Include approved listings in the Maintenance Manual.
- .4 Obtain receipt for delivered products and submit prior to final payment.

### **2.3. MAINTENANCE MATERIALS**

- .1 Provide maintenance and extra materials, in quantities specified in individual specification sections.
- .2 Provide items of same manufacture and quality as items in Work.
- .3 Receive and catalogue all items. Submit inventory listing to Consultant. Include approved listings in the Maintenance Manual.
- .4 Obtain receipt for delivered products and submit prior to final payment.

### **2.4. SPECIAL TOOLS**

- .1 Provide special tools, in quantities specified in the individual specification section.
- .2 Provide items with tags identifying their associated function and equipment.
- .3 Receive and catalogue all items. Submit inventory listing to Consultant. Include approved listings in the Maintenance Manual.

## **3.0 EXECUTION**

### **3.1. DELIVERY TO SITE**

- .1 Deliver to place of work and store.
- .2 General Contractor to receive and acknowledge delivery from contractors and subcontractors of all parts and materials assembled for maintenance requirements. Provide a summary inventory list to the Consultant and/or the Board after all materials are gathered and verification of location. Signatures of receipt will not be accepted from anyone except the General Contractor's representative.

### **3.2. STORAGE, HANDLING AND PROTECTION**

- .1 Consult with the Board to determine location for storage.
- .2 Store spare parts, maintenance materials, and special tools in manner to prevent damage or deterioration.
- .3 Store in original and undamaged condition with manufacturer's seal and labels intact.
- .4 Store components subject to damage from weather in weatherproof enclosures.
- .5 Store paints and freezable materials in a heated and ventilated room.
- .6 Remove and replace damaged products at own expense and to the satisfaction of the Consultant.

**END OF SECTION**

## **01 79 00 – Demonstration and Training**

### **1.0 GENERAL**

#### **1.1. SECTION INCLUDES**

- .1 Procedures for demonstration and instruction of Products, equipment and systems to Owner's personnel.
- .2 Seminars and demonstrations.

#### **1.2. RELATED SECTIONS**

- .1 This Section describes requirements applicable to all Sections within Divisions 02 to 49.

#### **1.3. DESCRIPTION**

- .1 At Substantial Performance, at a time acceptable to Owner and Consultant, but not before operations and maintenance manual have been reviewed and accepted by the consultant; contractor shall give a complete demonstration in the presence of consultant; Sub-consultants, Owner and Owner's personnel of operation and maintenance of systems and equipment once they are 100% complete.
- .2 Owner will provide a list of personnel to receive instructions and will coordinate their attendance at agreed-upon times.

#### **1.4. COMPONENT DEMONSTRATION**

- .1 Manufacturer to provide authorized representative to demonstrate operation of equipment and systems.
- .2 Instruct Owner's personnel, and provide written report that demonstration and instructions have been completed.

#### **1.5. SUBMITTALS**

- .1 Submit schedule of time and date for demonstration of each item of equipment and each system one (1) week prior to designated dates, for Consultant's approval.
- .2 Submit reports within forty eight (48) after completion of demonstration, that demonstration and instructions have been satisfactorily completed.
- .3 Give time and date of each demonstration, with a list of persons present.

## **1.6. CONDITIONS FOR DEMONSTRATIONS**

- .1 Equipment has been inspected and put into operation in accordance with manufacturer's instructions and contract requirements.
- .2 Testing, adjusting, and balancing have been performed in accordance with manufacturer's instructions and contract requirements, and equipment and systems are fully operational.
- .3 Provide information packages as required for use in demonstrations and instructions.

## **2.0 PRODUCTS**

### **2.1. NOT USED**

- .1 Not used.

## **3.0 EXECUTION**

### **3.1. PREPARATION**

- .1 Verify that suitable conditions for demonstration and instructions are available.
- .2 Verify that designated personnel are present.
- .3 Prepare agendas and outlines.
- .4 Establish seminar organization.
- .5 Explain component design and operational philosophy and strategy.
- .6 Develop equipment presentations.
- .7 Present system demonstrations.
- .8 Accept and respond to seminar and demonstration questions with appropriate answers.

### **3.2. PREPARATION OF AGENDAS AND OUTLINES**

- .1 Prepare agendas and outlines including the following:
  - .1 Equipment and systems to be included in seminar presentations.
  - .2 Name of companies and representatives presenting at seminars.
  - .3 Outline of each seminar's content.
  - .4 Time and date allocated to each system and item of equipment.
  - .5 Provide a separate agenda for each system.

### **3.3. SEMINAR ORGANIZATION**

- .1 Coordinate content and presentations for seminars.

- .2 Coordinate individual presentations and ensure representatives scheduled to present at seminars are in attendance.
- .3 Arrange for presentation leaders familiar with the design, operation, maintenance and troubleshooting of the equipment and systems. Where a single person is not familiar with all aspects of the equipment or system, arrange for specialists familiar with each aspect.
- .4 Coordinate proposed dates for seminars with Owner and select mutually agreeable dates.

### **3.4. EXPLANATION OF DESIGN STRATEGY**

- .1 Explain design philosophy of each system. Include following information:
  - .1 An overview of how the system is intended to operate.
  - .2 Description of design parameters, constraints and operational requirements.
  - .3 Description of system operation strategies.
  - .4 Information to help in identifying and troubleshooting system problems.

### **3.5. DEMONSTRATION AND INSTRUCTIONS**

- .1 Demonstrate start-up, operation, control, adjustment, trouble-shooting, servicing, and maintenance of each item of equipment.
- .2 Instruct personnel in all phases of operation and maintenance using operation and maintenance manuals as the basis of instruction.
- .3 Instruct personnel on control and maintenance of sensory equipment and operational equipment associated with maintaining energy efficiency and longevity of service.
- .4 Review contents of manual in detail to explain all aspects of operation and maintenance.
- .5 Prepare and insert additional data in operations and maintenance manuals when the need for additional data becomes apparent during instructions.

**END OF SECTION**

---

## **PART 1 - GENERAL**

### 1.1 General

- .1 Conform to Division 01 - General Requirements.

### 1.2 Related Sections

- .1 Section 01 35 43 – Hazardous Materials
- .2 Section 01 35 43A - Asbestos Audit Report.

### 1.3 Existing Conditions

- .1 Assume responsibility for demolition of structures in the condition they are at time notified of award of contract.
- .2 Inspect adjacent existing rooms and buildings to extent possible to ensure that its condition and stability is recorded in a manner suitable for evaluation of possible damage caused by work of this Section.

### 1.4 Designated Substances

- .1 Designated Substances to be removed prior to demolition by qualified trades following all regulatory requirements.

### 1.5 Work Included

- .1 Refer to Demolition Drawings for extent and scope of demolition work.

### 1.6 Protection

- .1 Demolition work shall be performed with adequate care being taken to prevent damage to surrounding work or material which is to remain the property of the Owner.
- .2 Prevent movement, settlement or damage of adjacent structures, services, existing elements to remain. Provide bracing, shoring, underpinning, as required. Make good all damage caused by demolition.
- .3 Take precautions to support affected structures, and if safety of building being demolished or adjacent structures or services appears to be endangered, cease operations and notify Consultant.
- .4 Prevent debris from blocking surface drainage system and mechanical and electrical systems which must remain in operation.
- .5 Provide protection from elements for all interior parts affected by demolition.
- .6 Fires and burning of waste or materials are not permitted.
- .7 **Do not bury waste or materials on site.**
- .8 Do not dispose of waste or volatile materials such as: mineral spirits, oil, petroleum based lubricants, or toxic cleaning solutions into watercourses, storm or sanitary sewers. Ensure proper disposal procedures are maintained throughout project.
- .9 Do not pump water containing suspended materials into watercourses, storm or sanitary sewers, or onto adjacent properties.
- .10 Control disposal or runoff of water containing suspended materials or other harmful substances in accordance with local authorities.
- .11 Protect trees, plants and foliage on site and adjacent properties where indicated.
- .12 Prevent extraneous materials from contaminating air beyond application area, by providing temporary enclosures during demolition work.
- .13 Cover or wet down dry materials to prevent blowing dust and debris. Control dust on all temporary roads.

1.7 Scheduling of Work

- .1 Demolition of structure and appurtenances as indicated on the Drawings is to be undertaken at times and dates as directed by the Consultant or as otherwise listed in this Specification.
- .2 Cooperation with subcontractors is necessary to prevent delays.

1.8 Subcontractor Qualifications

- .1 Execute the work of this Section by a subcontractor who has adequate plant, equipment and skilled tradespeople to perform the work expeditiously and who is known to have been responsible for similar satisfactory work.
- .2 Performance of all demolition work shall be in accordance with all regulations under the Ministry of Labour, including the Occupational Health and Safety Act, Ministry of the Environment and the Ontario Building Code.

**PART 2 - PRODUCTS**

2.1 Equipment

- .1 Equipment and heavy machinery to meet or exceed all applicable emission requirements.
- .2 Leave machinery running only while in use, except where extreme temperatures prohibit shutting machinery down.

**PART 3 - EXECUTION**

3.1 Examination

- .1 Before commencing any demolition, ensure thorough examination of the site and work to be demolished so that all possible factors concerning demolition are investigated and that the following are known:
  - .1 Methods and means available for materials handling, disposal, storage and transportation.
  - .2 Construction of structures to be demolished.

3.2 Preparation

- .1 Install protection consisting of barricades, signs and substantial constructions to provide physical protection.
- .2 Erect shoring and other structures to prevent collapse, settlement and movement.
- .3 Post danger signs. Barricade all access by unauthorized persons to areas in which demolition is in progress.
- .4 Re-route electrical and mechanical services entering/ leaving the building and which are to be reconnected. Post warning signs and erect barricades on electrical lines and equipment which may remain energized to serve parts of the buildings during period of demolition. Refer to Drawings.
- .5 Do not disrupt active or energized utilities traversing premises.
- .6 Employ rodent and vermin control and comply with health regulations during any such control procedures.

---

3.3 General

- .1 Perform all demolition under the direction of a competent foreman at all times.
- .2 Water down debris frequently to prevent the spread of dust.
- .3 Provide for complete and safe access at all times to areas adjacent to demolition work.

3.4 Demolition

- .1 Demolish complete structures as indicated and remove existing equipments and services as indicated. Carefully review Architectural, Structural, Mechanical and Electrical Drawings for specific requirements for demolition. **Contractors are required to view prior to Bidding.**
- .2 Carefully remove materials and equipment, and store, protect, and reinstall in building, using qualified tradesmen those items designated in the specifications or on Drawings to be reinstalled.
- .3 Carefully remove materials and equipment to be retained by the Owner as indicated on Drawings. Refer also to Mechanical and Electrical Sections of the Specifications and Drawings for equipment to be handed over to the Owner.
- .4 At the end of each day's work, leave work in a safe condition so that no part is in danger of collapse or falling.
- .5 Demolish masonry and concrete walls in small sections. Carefully remove and lower structural framing and other heavy or large objects.
- .6 Stockpile materials in a location within the Project Area which will not impede demolition activity. Eliminate double handling where possible.
- .7 Selling or burning of materials on site is not permitted.

3.5 Disposal

- .1 Unless otherwise specified in this Section, remove completely from the site, all debris resulting from demolition.
- .2 Designate an area on site for the separation and storage of waste materials. Allow enough space for multiple bins.
- .3 At a minimum, provide storage bins onsite for concrete, metal, wood, cardboard, plastic, gypsum board and mixed waste. Land clearing debris, asphalt and concrete can be stockpiled onsite, for further processing.
- .4 Remove debris daily, or as it accumulates. Do not overload trucks, take means to prevent spillage.
- .5 Remove contaminated or dangerous materials from site and dispose of in a safe manner to minimize danger on site or at any time during disposal.

3.6 Clean Up

- .1 Upon completion of work, remove debris, trim surfaces and leave work site clean.
- .2 Use only cleaning solutions and procedures which are not harmful to health, are not injurious to plants, and do not endanger wildlife, adjacent watercourses or ground water.

END OF SECTION

---

## **PART 1 - GENERAL**

### 1.1 General

- .1 Conform to Division 01 – General Requirements.

### 1.2 Related Sections

- .1 Section 04 05 12 – Masonry Mortar and Grout.
- .2 Section 04 05 19 – Masonry Anchorage and Reinforcing.
- .3 Section 04 05 23 – Masonry Accessories.
- .4 Section 04 21 13 – Brick Masonry.
- .5 Section 04 22 00 – Concrete Unit Masonry.
- .6 Section 07 92 00 – Joint Sealing.

### 1.3 References

- .1 Canadian Standards Association (CSA)
  - .1 CSA A179-14, Mortar and Grout for Unit Masonry.
  - .2 CSA-A371-14, Masonry Construction for Buildings.

### 1.4 Samples

- .1 Submit samples in accordance with Section 01 33 00 - Submittal Procedures.
- .2 Submit samples:
  - .1 Two of each type of masonry unit specified.
  - .2 One of each type of masonry accessory specified.
  - .3 One of each type of masonry reinforcement, tie and connector proposed for use.
  - .4 As required for testing purposes.

### 1.5 Test Reports

- .1 Submit laboratory test reports certifying compliance of masonry units and mortar ingredients with specification requirements.

### 1.6 Delivery, Storage and Handling

- .1 Deliver, store, handle and protect materials in accordance with Section 01 60 00 - Basic Product Requirements.
- .2 Deliver materials to job site in dry condition.
- .3 Keep materials dry until use except where wetting of bricks is specified.
- .4 Store under waterproof cover on pallets or plank platforms held off ground by means of plank or timber skids.
- .5 Note that there are restrictions for the new floors with respect to the type of equipment used to move materials and the weight of the materials being moved. Refer to Structural Drawings for additional details.

### 1.7 Environmental Requirements

- .1 Cold weather requirements:
  - .1 Supplement Clause 6.7.2 of CSA A371-14 with following requirements:
    - .1 Maintain temperature of mortar between 5°C and 50°C until batch is used.
  - .2 When air temperature is below 5°C the requirements for masonry construction shall be in accordance with CSA A371-14 Section 6.7.2.
  - .3 Maintain dry beds for masonry and use dry masonry units only. Do not wet masonry units in cold weather.

- 
- .4 Completed masonry or sections not being worked on shall be protected in accordance with CSA A371-14 Section 6.7.3.
  - .2 Hot weather requirements to be in accordance with Clause 6.7.4 of a CSA A371-14:
    - .1 Protect freshly laid masonry from drying too rapidly, by means of waterproof, non-staining coverings.
    - .2 Keep masonry dry using waterproof, non-staining coverings that extend over walls and down sides sufficient to protect walls from wind driven rain, until masonry work is completed and protected by flashings or other permanent construction.
- 1.8 Protection
- .1 Keep masonry dry using waterproof, non-staining coverings that extend over walls and down sides sufficient to protect walls from wind driven rain, until masonry work is completed and protected by flashings or other permanent construction.
  - .2 Protect masonry and other work from marking and other damage. Protect completed work from mortar droppings. Use non-staining coverings.
  - .3 Provide temporary bracing of masonry work during and after erection until permanent lateral support is in place.

## **PART 2 - PRODUCTS**

### 2.1 Materials

- .1 Masonry materials are specified in related Sections indicated in 1.2.

## **PART 3 - EXECUTION**

### 3.1 Installation

- .1 Do masonry work in accordance with CSA-A371 except where specified otherwise.
- .2 Build masonry plumb, level, and true to line, with vertical joints in alignment.
- .3 Layout coursing and bond to achieve correct coursing heights, and continuity of bond above and below openings, with minimum of cutting.

### 3.2 Construction

- .1 Exposed masonry
  - .1 Remove chipped, cracked, and otherwise damaged units in exposed masonry and replace with undamaged units.
  - .2 Exposed block masonry to be reviewed upon application of first coat of paint.
- .2 Jointing
  - .1 Allow joints to set just enough to remove excess water, then tool with round jointer to provide smooth, joints true to line, compressed, uniformly concave joints where concave joints are indicated.
  - .2 Rake joints uniformly to 6mm depth and compress with square tool to provide smooth, compressed, raked joints of uniform depth where raked joints are indicated.
  - .3 Strike flush all joints concealed in walls and in walls to receive gypsum board, plaster, tile, insulation, stucco, or other applied material except paint or similar thin finish coating.

- 
- .3 Joining of work
    - .1 Where necessary to temporarily stop horizontal runs of masonry, and in building corners:
      - .1 Step-back masonry diagonally to lowest course previously laid.
      - .2 Do not "tooth" new masonry.
      - .3 Fill in adjacent courses before heights of stepped masonry reach 1200mm.
  - .4 Cutting
    - .1 Cut out for electrical switches, outlet boxes, and other recessed or built-in objects.
    - .2 Make cuts straight, clean, and free from uneven edges.
  - .5 Building-In
    - .1 Build in items required to be built into masonry.
    - .2 Prevent displacement of built-in items during construction. Check plumb, location and alignment frequently, as work progresses.
    - .3 Brace door jambs to maintain plumb. Fill spaces between jambs and masonry with mortar.
  - .6 Wetting of bricks
    - .1 Except in cold weather, wet bricks having an initial rate of absorption exceeding 1 g/minute/1000 mm<sup>2</sup>: wet to uniform degree of saturation, 3 to 24 hours before laying, and do not lay until surface dry.
    - .2 Wet tops of walls built of bricks qualifying for wetting, when recommencing work on such walls.
  - .7 Support of loads
    - .1 Use concrete of strength(s) indicated in Section 03 30 00 - Cast-in-Place Concrete, where concrete fill is used in lieu of solid units.
    - .2 Use grout to CSA A179 where grout is used in lieu of solid units.
    - .3 Install building paper below voids to be filled with concrete or grout; keep paper 25mm back from faces of units.
  - .8 Provision for movement
    - .1 Except for walls designated as shear walls on the Structural Drawings, where no space for movement is to be provided;
      - .1 Leave 3mm space below shelf angles.
      - .2 Leave 6mm space between top of non-load bearing walls and partitions and structural elements. Do not use wedges.
    - .2 Build masonry to tie in with stabilizers, with provision for vertical movement.
  - .9 Loose steel lintels
    - .1 Install loose steel lintels at all openings greater than one masonry unit length. Centre over opening width; provide 200mm bearing each side.
  - .10 Control joints
    - .1 Except for walls designated as shear walls on the Structural Drawings, where no control joints are to be provided:
      - .1 Construct continuous control joints as indicated, and:
        - .1 at intersections of interior block walls with exterior block walls.
        - .2 at locations between walls on foundations and walls on thickened slabs
        - .3 over window and door jambs.
    - .2 Block reinforcement to be continuous at exterior control joints and at intersections of interior block walls with exterior block walls, non-continuous at interior control joints.
    - .3 Rake joints full height 10mm x 20mm and caulk to Section 07 92 00.
  - .11 Penetration of masonry
    - .1 Fill voids of masonry to within 19mm of structural members, pipes, ducts and conduit that penetrate masonry walls and partitions, unless otherwise indicated.
    - .2 Keep masonry units similarly clear of such penetrations.
    - .3 Finish mortar smooth at face of masonry.

- .4 Pack remainder of annular void surrounding penetrating items with fire separation packing to within 12.7mm of face of masonry. Install sealant to maintain fire ratings where required.
- .12 Adjustment and cleaning
  - .1 Patch damaged masonry walls which have been rejected.
  - .2 Point all holes in mortar joints except weepholes.
  - .3 Point all voids in concrete unit masonry faces.
  - .4 Cut out defective mortar joints to a minimum depth of 13mm and repoint.
  - .5 Wash down and brush masonry to remove mortar and stains. Use only detergents, or proprietary masonry cleaners as recommended by masonry manufacturer.

### 3.3 Site Tolerances

- .1 Tolerances CSA A371-14 apply:
  - .1 Clause 6.2 for surfaces and lines;
  - .2 Clause 7.1.2.2. for bed joints below the first course of masonry;
  - .3 Clause 13.2.2. for width of air space in cavity and veneer systems.

END OF SECTION

## **PART 1 - GENERAL**

### 1.1 General

- .1 Conform to Division 01 - General Requirements.

### 1.2 Related Sections

- .1 Section 04 05 10 – Common Work Results for Masonry.

### 1.3 References

- .1 Canadian Standards Association (CSA)
  - .1 CSA A179-14, Mortar and Grout for Unit Masonry.

## **PART 2 - PRODUCTS**

### 2.1 Materials

- .1 Use same brands of materials and source of aggregate for entire project.
- .2 Mortar and grout: CSA A179-14.
- .3 Dirt resistant additives: Aluminum tristearate, calcium stearate or ammonium stearate.
- .4 Use aggregate passing 1.18mm sieve where 6mm thick joints are indicated.
- .5 All mortar to be prepared based on property specifications, as per CSA A179.
- .6 Mortar for exterior masonry above grade:
  - .1 Loadbearing: Type S.
  - .2 Non-loadbearing: Type N.
  - .3 Parapet walls, chimneys, unprotected walls: Type S.
- .7 Mortar for interior masonry:
  - .1 Loadbearing: Type S.
  - .2 Non-loadbearing: Type N.
- .8 The following applies regardless of mortar types and uses specified above:
  - .1 Mortar for grouted reinforced masonry: Type S.
  - .2 Mortar for pointing: Type S.
- .9 Non-staining mortar: use non-staining masonry cement for cementitious portion of specified mortar type.
- .10 Type S mortar should be proportioned to meet the property specification minimum strength requirements but be less strength than the block strength of 20 MPa.

### 2.2 Mixes

- .1 Colour and admixtures: Mix grout to semi-fluid consistency.
- .2 Pointing mortar: Prehydrate pointing mortar by mixing ingredients dry, then mix again adding just enough water to produce damp unworkable mix that will retain its form when pressed into ball. Allow to stand for not less than 1 hour nor more than 2 hours then remix with sufficient water to produce mortar of proper consistency for pointing.

## **PART 3 - EXECUTION**

### 3.1 Construction

- .1 Do masonry mortar and grout work in accordance with CSA A179 except where specified otherwise.

END OF SECTION

---

## **PART 1 - GENERAL**

### 1.1 General

- .1 Conform to Division 01 - General Requirements.

### 1.2 Related Work

- .1 Section 04 05 10 – Common Work Results for Masonry.
- .2 Section 04 05 12 – Masonry Mortar and Grout.
- .3 Section 04 05 23 – Masonry Accessories.
- .4 Section 04 21 13 – Brick Masonry.
- .5 Section 04 22 00 – Concrete Unit Masonry.

### 1.3 References

- .1 Canadian Standards Association (CSA)
  - .1 CSA-A23.1-M14, Concrete Materials and Methods of Concrete Construction.
  - .2 CSA-A370-M14, Connectors for Masonry.
  - .3 CSA-A371-M14, Masonry Construction for Buildings.
  - .4 Withdrawn - Replaced by CSA G30.14-M1983 (R1998), Formed Steel Wire For Concrete Reinforcement.
  - .5 CSA G30.18-M92, Billet-Steel Bars for Concrete Reinforcement.
  - .6 CSA-S304-.1M14, Masonry Design for Buildings.
  - .7 CSA W186-M1990, Welding of Reinforcing Bars in Reinforced Concrete Construction.
  - .8 CSA A179-14, Mortar and Grout for Unit Masonry.

### 1.4 Source Quality Control

- .1 Provide Consultant with certified copy of mill test report of reinforcement steel and connectors, showing physical and chemical analysis, prior to commencing reinforcement work.
- .2 Inform Consultant of proposed source of material to be supplied.

### 1.5 Shop Drawings

- .1 Submit shop drawings in accordance with Section 01 33 00 - Submittal Procedures.
- .2 Shop drawings consist of bar bending details, lists and placing drawings.
- .3 On placing drawings, indicate sizes, spacing, location and quantities of reinforcement and connectors.

## **PART 2 - PRODUCTS**

### 2.1 Materials

- .1 Bar reinforcement: to CSA-A371-14 and CSA G30.18, Grade 400MPa.
  - .1 Vertical reinforcing bars as indicated on Structural Drawings.
- .2 Wire reinforcement: to CSA-A371-14 and CSA G30.14:
  - .1 Concrete Block for non-load bearing interior masonry walls: Standard 3.7mm hot dipped galvanized two-wire ladder of truss type reinforcing by Blok-Lok or Hohmann & Barnard. BL30 by Blok Lok, or 120 Truss-Mesh by Hohmann & Barnard.

- .2 Concrete Block for interior wythe of non-load bearing exterior cavity walls: Standard 3.7mm hot dipped galvanized two-wire ladder of truss type reinforcing by Blok-Lok or Hohmann & Barnard. BL30 by Blok Lok, or 120 Truss-Mesh by Hohmann & Barnard
- .3 Load Bearing Concrete Block at either interior or exterior masonry walls: Heavy Duty hot dipped galvanized two-wire ladder of truss type reinforcing with 4.66mm longitudinal wires and 3.66mm diagonal wires by Blok-Lok or Hohmann & Barnard. BL30 by Blok Lok, or 120 Truss-Mesh by Hohmann & Barnard
- .4 Provide prefabricated corners and tees to match wire size and truss arrangement in item 2.1.2.1 to 2.1.2.3 above.
- .5 Extra wire reinforcing is required in all stack bond veneers: Provide a hot dipped galvanized 3.66mm diameter wire centred in the brick veneer. Provide Hohmann & Barnard DW-10HS Seismic veneer anchor to anchor veneer tie to single wire reinforcing.
- .3 All Connectors to be in accordance with CSA-A370-14 and CSA-S304.
  - .1 For masonry connectors which connect masonry veneers to concrete walls or concrete column back-up provide: Stainless Steel Fero Holed L-plate by Fero Corporation, or approved alternate.
  - .2 For masonry connectors which connect masonry veneers to concrete block back-up provide: Stainless Steel Fero Block Shear Connectors by Fero Corporation. or approved alternate. Refer to Structural typical detail 4-H.
  - .3 For masonry connectors which connect masonry veneers to steel stud back up provide: Stainless Steel Fero Side Mounting Rap Tie or approved alternate. Provide dielectric between connector and steel stud.
- .4 Ties from masonry connectors to masonry veneer:
  - .1 Ties from Fero Holed L-plate to masonry veneer: provide stainless steel 4.67mm diameter v-tie of sufficient length to extend to middle of brick veneer as manufactured by Fero Corporation or approved equal.
  - .2 Ties from Fero Block Shear Connector to masonry veneer: provide stainless steel 4.67mm diameter v-tie of sufficient length to extend to middle of brick veneer as manufactured by Fero Corporation or approved equal.
  - .3 Ties from steel stud bayonet connectors as supplied be light gauge structural steel stud contractor to masonry veneer: provide stainless steel 4.67mm diameter v-tie of sufficient length to extend to middle of brick veneer as manufactured by Fero Corporation or approved equal.
- .5 General ties between masonry items or ties to structural steel items.
  - .1 Ties from built in structural steel items as indicated in structural typical detail 4-A: provide hot dipped galvanized 6mm diameter v-tie of sufficient length as indicated in typical details. Fero Vee Ties as manufactured by Fero Corporation, or BYNA-Tie as manufactured by Hohmann & Barnard.
  - .2 Z-ties to connect between masonry items. Provide standard 6mm diameter hot dipped galvanized 'Z' ties. Unless noted otherwise provide minimum of 200mm embedment in each masonry component.
- .6 Bolts and Anchors: to CAN3-A370-M14.

## 2.2 Fabrication

- .1 Fabricate reinforcing in accordance with CSA-A23.1 and Reinforcing Steel Manual of Standard Practice by the Reinforcing Steel Institute of Ontario.
- .2 Fabricate connectors in accordance with CSA-A370.
- .3 Obtain Consultant's approval for locations of reinforcement splices other than shown on placing drawings.
- .4 Upon approval of Consultant, weld reinforcement in accordance with CSA W186.
- .5 Ship reinforcement and connectors, clearly identified in accordance with drawings.

**PART 3 - EXECUTION****3.1 General**

- .1 Supply and install masonry connectors and reinforcement in accordance with CSA-A370, CSA-A371, CSA-A23.1 and CSA-S304.1 unless indicated otherwise.
- .2 Prior to placing mortar, obtain Consultant's approval of placement of reinforcement and connectors.

**3.2 Horizontal Reinforcing**

- .1 Install in each wythe of masonry elements at 400mm maximum, horizontal reinforcement, each rod centred on narrowest face shell and lapped 20mm at splices. At exterior masonry walls with masonry veneer alternate horizontal reinforcing with Fero ties.

**3.3 Bonding and Tying**

- .1 Bond walls of two or more wythes using metal connectors in accordance with CSA-A371-M14.
- .2 Tie masonry veneer to backing in accordance with NBC, CSA-S304.1, CSA-A371 and as follows:
  - .1 Tie masonry veneer to backing at 400mm o.c. horizontally and 600mm o.c. vertically, unless noted otherwise on Structural Drawings.
  - .2 Provide ties 200mm from openings.
  - .3 Provide veneer anchors as detailed on Structural Drawings.
  - .4 Provide ties top and bottom of soldier courses and precast band courses.

**3.4 Reinforced Lintels and Bond Beams**

- .1 Reinforce masonry lintels and bond beams as indicated.
- .2 Place and grout reinforcement in accordance with CSA-S304.1, CSA-A371, and CSA-A179 and as indicated.

**3.5 Grouting**

- .1 Grout masonry in accordance with CSA-S304.1, CSA-A371 and CSA-A179 and as indicated.

**3.6 Anchors**

- .1 Supply and install metal anchors as indicated on Structural Drawings.

**3.7 Lateral Support and Anchorage**

- .1 Supply and install lateral support and anchorage in accordance with CSA-S304.1 and as indicated on Structural Drawings.

**3.8 Movement Joints**

- .1 Reinforcement will not be continuous across movement joints unless otherwise indicated.

**3.9 Field Bending**

- .1 Do not field bend reinforcement and connectors except where indicated or authorized by Consultant. Provide prefabricated corners and tees at all block intersections.

- .2 When field bending is authorized, bend without heat, applying a slow and steady pressure.
  - .3 Replace bars and connectors which develop cracks or splits.
- 3.10 Field Touch-up
- .1 Touch up damaged and cut ends of epoxy coated or galvanized reinforcement steel and connectors with compatible finish to provide continuous coating.

END OF SECTION

---

## **PART 1 - GENERAL**

### 1.1 General

- .1 Confirm to Division 01 – General Requirements.

### 1.2 Related Sections

- .1 Section 04 05 10 – Common Work Results for Masonry.
- .2 Section 04 05 19 – Masonry Anchorage and Reinforcing.

### 1.3 References

- .1 American Society for Testing and Materials (ASTM)
  - .1 ASTM D 2240-15e1, Standard Test Method for Rubber Property - Durometer Hardness.
- .2 Canadian Standards Association (CSA)
  - .1 CAN3-A371-14, Masonry Construction for Buildings.

## **PART 2 - PRODUCTS**

### 2.1 Materials

- .1 Backing rod: neoprene, to suit width of control joint.
- .2 Control joint filler: purpose-made elastomer durometer hardness to ASTM D 2240 of size and shape indicated.
- .3 Lap adhesive: recommended by masonry flashing manufacturer.
- .4 Weep hole vents: purpose-made polyvinyl chloride designed to drain cavities to exterior, size to suit height of masonry units; Goodco PVC; colour: black.
- .5 Nailing inserts: 0.6mm thick purpose made galvanized steel inserts for setting in mortar joints.
- .6 Masonry flashings:
  - .1 Dampproof: polyethylene; 0.15mm thick; black.
  - .2 Flashing membrane: 1.00mm minimum thickness, reinforced membrane: Sopraseal 3000 by Soprema; Sealtight MEL-ROL as manufactured by W.R. Meadows, or Blueskin TWF as manufactured by Bakor. Install in width to suit wall thickness.
  - .3 Flashing adhesive as recommended by manufacturer.
- .7 Flashing support:
  - .1 Rigid insulation; 38mm minimum thickness as per Section 07 21 13.
  - .2 Sheet metal: 0.55mm cold rolled to meet ASTM Specification B370, formed with 75mm wide flanges with hemmed or offset edges to form anchorage in mortar joint (at high/low roof transitions).
- .8 Mortar dropping control devices: high density polypropylene designed to control mortar droppings to ensure clear air space in cavity walls; MORTAR NET DA1008 by Dur-O Wal.
- .9 Joint packing at walls:
  - .1 Fire separation packing: To CAN/ULC-S115; "A/D Firebarrier" mineral wool firestopping by A/D Distributors Ltd., "RXL SAFE" mineral wool by Roxul Inc., "Fire-Bloc" by M.W. McGill & Associates Ltd.
  - .2 Expansion joint packing: Glass fibre insulation, rigid board, density of 48kg/m<sup>3</sup>.
  - .3 Sealant: single component silicone to CAN/ULC-S115; A/D Silicone Firebarrier Sealant, "Fyresil-SL" by Tremco Ltd.

---

### **PART 3 - EXECUTION**

#### 3.1 Installation

- .1 Install continuous control joint fillers in control joints at locations indicated on Drawings.
- .2 Install weep hole vents in vertical joints immediately over flashings in, and at tops of exterior wythes of cavity wall and masonry veneer wall construction, at maximum horizontal spacing of 600mm o.c., and as shown on Drawings.

#### 3.2 Construction

- .1 Build in flashings in masonry in accordance with CAN3-A371-14, and as follows:
  - .1 Install dampproof flashing under exterior masonry bearing on foundation walls prior to commencing laying of masonry wall.
  - .2 Install flashings, slabs, shelf angles, and steel angles over openings. Install flashings under weep hole courses and as indicated.
  - .3 In cavity walls and veneered walls, carry flexible flashings from front edge of masonry, under outer wythe, then up backing not less than 300mm, and as follows:
    - .1 For masonry backing, embed flashing 25mm in masonry joint, install remainder of flashing just prior to installation of insulation and behind the embedded flashing, remove backing paper from embed flashing and adhere to base flashing.
    - .2 For concrete backing, insert flashing into reglets.
    - .3 For gypsum board backing, bond to wall using manufacturer's recommended adhesive.
  - .4 Where walls pass roofing construction details:
    - .1 Install air/ vapour transition strip from roof deck to underside of metal through-wall flashing into reglet. Roofing contractor to install metal through-wall flashing out over roof membrane. Install flexible through-wall flashing to be interlocked and have folded top edge, fastened at 610mm o.c. through folded edge. Provide mastic bead along top edge.
    - .5 Lap joints 150mm and seal with adhesive.
    - .6 At steps, extend flashings 150mm beyond step below.
- .2 Mortar control dropping devices: Install in exterior wythe horizontal masonry joints 100mm and 200mm above top of foundation, elevated floor lines and opening head flashings, in strict accordance with manufacturer's written instructions.
- .3 Fire separations:
  - .1 Construct fire separation walls tightly to construction at perimeter, and without openings or voids.
  - .2 Do not reduce the thickness of masonry separations to less than the thickness indicated for the required fire separation rating.
  - .3 Install fire separation packing in openings less than 75mm high at top of walls.
  - .4 Install sealant on each side of fire separation packing where required to maintain integrity of fire rating of wall/ floor.
  - .5 Submit ULC approval of system upon request of the Consultant.

END OF SECTION

## **PART 1 - GENERAL**

### 1.1 General

- .1 Conform to Division 01 – General Requirements.

### 1.2 Related Sections

- .1 Section 04 05 10 – Masonry Procedures.
- .2 Section 04 05 12 – Masonry Mortar and Grout.
- .3 Section 04 05 19 – Masonry Anchorage and Reinforcing.
- .4 Section 04 05 23 – Masonry Accessories.
- .5 Section 04 22 00 – Concrete Masonry Units.
- .6 Section 07 92 00 – Joint Sealers.

### 1.3 References

- .1 American Society for Testing and Materials (ASTM)
  - .1 ASTM C 126-09, Standard Specification for Ceramic Glazed Structural Clay Facing Tile, Facing Brick, and Solid Masonry Units.
- .2 Canadian Standards Association (CSA)
  - .1 CAN/CSA-A82-06 (R2011), Burned Clay Brick (Solid Masonry Units Made From Clay or Shale).

## **PART 2 - PRODUCTS**

### 2.1 Manufactured Units

- .1 Face brick.
  - .1 Use salvaged brick.

## **PART 3 - EXECUTION**

### 3.1 Installation

- .1 Bond: running stretcher – refer to Drawings. Match existing brick pattern.
- .2 Coursing height (running bond): 200mm +/- for three bricks and three joints.
- .3 Jointing: concave exterior, raked interior where exposed.
- .4 Mixing and blending: mix units within each pallet and with other pallets to ensure uniform blend of colour and texture.
- .5 Clean unglazed clay masonry as work progresses.

3.2 Cleaning

- .1 Clean unglazed clay masonry: mock up panel specified in Section 04 05 10 - Masonry procedures as directed below and leave for one week. If no harmful effects appear and after mortar has set and cured, protect windows, sills, doors, trim and other work, and clean brick masonry as follows:
  - .1 Remove large particles with wood paddles without damaging surface. Saturate masonry with clean water and flush off loose mortar and dirt.
  - .2 Scrub with solution of 25 mL trisodium phosphate and 25 mL household detergent dissolved in 1 L of clean water using stiff fibre brushes, then clean off immediately with clean water using hose. Alternatively, use proprietary compound recommended by brick masonry manufacturer in accordance with manufacturer's directions.
  - .3 Repeat cleaning process as often as necessary to remove mortar and other stains.
  - .4 Use acid solution treatment for difficult to clean masonry as described in Technical Note No.20 published by Brick Institute of America dated Sept./Oct. 1977.

END OF SECTION

---

## **PART 1 - GENERAL**

### 1.1 General

- .1 Conform to Division 01 – General Requirements.

### 1.2 Related Sections

- .1 Section 04 05 10 – Common Work Results for Masonry.
- .2 Section 04 05 12 – Masonry Mortar and Grout.
- .3 Section 04 05 19 – Masonry Anchorage and Reinforcing.
- .4 Section 04 05 23 – Masonry Accessories.
- .5 Section 04 21 13 – Brick Masonry.
- .6 Refer to Structural Drawings.

### 1.3 References

- .1 A165 Series-04 CSA Standard on Concrete Masonry Units.

## **PART 2 - PRODUCTS**

### 2.1 Materials

- .1 Standard concrete block units (CB): to CSA CAN3-A165.1 standards.
  - .1 Classification: H/15/A /M.
  - .2 Size: imperial.

## **PART 3 – EXECUTION**

### 3.1 Installation

- .1 Concrete block units.
  - .1 Bond: running.
  - .2 Coursing height: 200mm +/- for one block and one joint.
  - .3 Jointing: concave where exposed or where paint or other finish coating is specified.
- .2 When patching/ repairing openings in existing walls, tooth-in concrete block using salvage block where possible or imperial block, **so that are no cut blocks left as a result of the repair. Match existing mortar joints, both in level and size.**

### 3.2 Cleaning

- .1 Allow mortar droppings on masonry to partially dry then remove by means of trowel, followed by rubbing lightly with small piece of block and finally by brushing.

END OF SECTION

---

**PART 1 - GENERAL**

1.1 General

- .1 Conform to Division 01 - General Requirements.

1.2 Related Sections

- .1 Section 07 92 10 - Joint Sealers.

1.3 Quality Assurance

- .1 Sub-contractor Qualifications
  - .1 Provide metal fabrications specified in this Section only by a fabricator who has adequate plant, equipment and skilled tradesmen to fabricate and install metal fabrications expeditiously and is known to have been responsible for satisfactory installations similar to that specified during a period of at least the immediate past five (5) years.
  - .2 Welder Qualifications
    - .1 Weld structural components as follows:
      - .1 Steel; to conform to requirements of CSA Standard W59 and by a fabricator fully certified by the Canadian Welding Bureau to conditions of CSA Standard W47.1 and W55.3.
      - .2 Aluminum; by a fabricator fully certified by the Canadian Welding Bureau to requirements of CSA Standard W47.2.

1.4 Requirements of Regulatory Agencies

- .1 Metal fabrications which function to resist forces imposed by dead and live loads shall conform to requirements of jurisdictional authorities.
- .2 Submit shop drawings to authorities when requested.

1.5 References

- .1 American Society for Testing and Materials (ASTM)
  - .1 ASTM A 53/A53M-99b, Specification for Pipe, Steel, Black and Hot-Dipped, Zinc Coated Welded and Seamless.
  - .2 ASTM A 269-98, Specification for Seamless and Welded Austenitic Stainless Steel Tubing for General Service.
  - .3 ASTM A 307-97, Specification for Carbon Steel Bolts and Studs, 60,000 PSI Tensile Strength.
  - .4 ASTM A780-80, Standard Practice for Repair of damaged Hot Dip Coatings.
- .2 Canadian General Standards Board (CGSB)
  - .1 CAN/CGSB-1.40-97, Anti-corrosive Structural Steel Alkyd Primer.
  - .2 CAN/CGSB-1.108-M89, Bituminous Solvent Type Paint.
  - .3 CAN/CGSB-1.181-92, Ready-Mixed, Organic Zinc-rich coating.
- .3 Canadian Standards Association (CSA)
  - .1 CAN/CSA-G40.20/G40.21-98, General Requirements for Rolled or Welded Structural Quality Steel.
  - .2 CAN/CSA-G164-M92(R1998), Hot Dip Galvanizing of Irregularly Shaped Articles.
  - .3 CAN/CSA-S16.1-94, Limit States Design of Steel Structures.
  - .4 CSA W47.1-92, Certification of Companies for Fusion Welding of Steel Structures.

- 
- .5 CSA W55.3-1965, Resistance Welding Qualification Code for Fabricators of Structural Members used in Buildings.
  - .6 CSA W59-M1998, Welded Steel Construction.
- 1.6 Shop Drawings
- .1 Submit shop drawings in accordance with Section 01 33 00 - Submittal Procedures.
  - .2 Indicate materials, core thicknesses, finishes, connections, joints, method of anchorage, number of anchors, supports, reinforcement, details and accessories.
- 1.7 Delivery, Storage and Handling
- .1 Deliver, store, handle and protect materials in accordance with Section 01 61 00 - Product Requirements.
  - .2 Label, tag or otherwise mark metal fabrications supplied for installation by other sections to indicate their function, location in building and shop drawing designation.
  - .3 Protect metal fabrications from damage during delivery, storage and handling. Protect prime painted and galvanized surfaces from damage.
  - .4 Cover exposed surfaces of stainless steel or prefinished metal which does not receive site finishing, with protective coatings or wrappings, prior to shipping to job site. Use materials recommended by finishers or manufacturers of metals, to ensure that method is sufficiently protective, easily removed and harmless to the finish.
  - .5 Leave protective covering in place until final cleaning of building. Provide instructions for removal of protective covering.

## **PART 2 - PRODUCTS**

### 2.1 Materials

- .1 Include all materials, products, accessories and supplementary parts necessary to complete assembly and installation of metal fabrications specified in this Section.
- .2 Incorporate only metals that are free from defects which impair strength or durability or which are visible.
- .3 Install only new materials of best quality and free from rust, waves and buckles, that are clean, straight with sharply defined profiles conforming to requirements of the following standards and specifications:
  - .1 Steel sections and plates: to CAN/CSA-G40.20/G40.21, Grade 300W.
  - .2 Hollow Structural Sections: to CAN/CSA G40.21, Grade 350W.
  - .3 Welding materials: to CSA W59-M1998.
  - .4 Bolts and anchor bolts: to ASTM A 307.
  - .5 Galvanizing: hot dipped galvanizing with zinc coating of 600 g/m<sup>2</sup> to CAN/CSA-G164.
  - .6 Shop coat primer: to CAN/CGSB-1.40.
  - .7 Galvanized primer: zinc-rich, ready mix to CAN/CGSB-1-181.
  - .8 Bituminous paint: to CAN/CGSB-1.108.
  - .9 Grout: non-shrink, non-metallic, flowable, 15 MPa at 24 hours.

### 2.2 Fabrication

- .1 Fabricate work specified in this Section with machinery and tools specifically designed for the intended manufacturing processes and by skilled tradesmen.
- .2 Fabricate work with materials, component sizes, metal gauges, reinforcing, anchors and fastenings of adequate strength to withstand intended use and within allowable design factors imposed by jurisdictional authorities.

- .3 Fabricate work square, straight and accurate to required size, with joints closely fitted and properly secured.
- .4 Incorporate means for fastening of other installations secured to metal fabrications. Pre-punch holes in members to allow for installation of mechanical and/ or electrical items.
- .5 Ensure that metal fabrications will remain free of warping, buckling, opening of joints and seams, distortion and permanent deformation.
- .6 Provide for differential movement within assemblies and at junctions of assemblies with surrounding construction.
- .7 Cleanly and smoothly finish exposed edges of materials including holes. Machine or grind components to ensure level bearings.
- .8 Cap open ends of sections exposed to view, such as pipes, channels, angles and other similar members.

### 2.3 Assembly

- .1 Where possible, fit and shop assemble work, ready for erection.
- .2 Accurately cut, machine and fit joints, corners, copes and mitres so that junctions between components fit together tightly and in true planes.
- .3 Conceal fastenings from view unless otherwise indicated on Drawings.
- .4 Weld all connections where possible; bolt where not possible and cut off bolts flush with nuts. Countersink bolt heads and provide method to prevent loosening of nuts.
- .5 Use self-tapping shakeproof countersunk flat headed screws on items requiring assembly by screws or as indicated on Drawings.
- .6 Weld joints tight, flush and in true planes with base metals. Ensure exposed welds are continuous for length of each joint. File or grind exposed welds smooth and flush where exposed to view.

### 2.4 Finishing

- .1 Clean all loose mill scale, rust, dirt, weld flux and spatter from work after fabrication. Grind smooth sharp projections.
- .2 Unless otherwise specified, apply one (1) coat of shop primer to all metal items, with the exception of those to be field welded, galvanized or concrete encased. Give surfaces that are inaccessible to finish field painting, two (2) coats of primer.
- .3 Paint steel members under cover in shop and keep them under cover until paint has dried. Use primer unadulterated, as prepared by manufacturer. Force paint into corners and cover open areas smoothly with a uniform coating.
- .4 Deliver metal fabrications to site with primer undamaged.

### 2.5 Galvanizing

- .1 After fabrication galvanize all exterior work unless noted otherwise.
- .2 Fabricate items to be galvanized as recommended in Appendix A and B of CSA G164.
- .3 Hot dip galvanize assemblies following their fabrication except where impossible.
- .4 Paint galvanized surfaces that are cut, welded or threaded with zinc rich paint to ensure a minimum coating thickness of 0.102mm, immediately following damage to galvanized protection. Prepare and repair surfaces to meet specified requirements of ASTM A780.

### 2.6 Isolation Coating

- .1 Isolate aluminum from following components, by means of bituminous paint:
  - .1 Dissimilar metals except stainless steel, zinc or white bronze of small area.
  - .2 Concrete, mortar and masonry.
  - .3 Wood.

---

### **PART 3 - EXECUTION**

#### 3.1 Installation

- .1 Install metal fabrications plumb, true, square, straight, level and accurately and tightly fitted together and to surrounding construction.
- .2 Provide suitable means of anchorage acceptable to the Consultant such as anchor bolts, bolts with washers and nuts, lag screws, expansion shields, toggles, straps, sleeves, brackets, clips and other items necessary for secure installation as required by loading and jurisdictional authorities.
- .3 Make field connections with bolts to CAN/CSA-S16.1 or weld in accordance with CSA W59.
- .4 Exposed fastening devices to match finish and be compatible with material through which they pass.
- .5 Attach metal fabrications to masonry with lead plugs and galvanized steel or other corrosion resistant fastenings to support load with a safety factor of three (3).
- .6 Grout metal posts, pickets, balusters, etc. in metal sleeves cast into concrete with sulphur, molten lead or quick setting anchor cement, unless detailed otherwise. Fabricate sleeves to 150mm minimum depth.
- .7 Countersink pilot holes provided for wood screws where wood is attached to metal fabrications.
- .8 Insulate between dissimilar metals; or between metal and masonry or concrete with bituminous paint to prevent electrolysis.
- .9 Caulk to Section 07 92 10 - Joint Sealing between components installed by this Section to seal joints against passage of air, water or both.
- .10 Hand items over for casting into concrete or building into masonry to appropriate trades together with setting templates.

#### 3.2 Adjustment and Cleaning

- .1 After installation, touch-up primed surfaces that are burnt, scratched or otherwise damaged with prime paint to match shop coat.
- .2 Repair areas of bare metal and welds on galvanized surfaces with zinc rich paint.
- .3 Do not field paint when air temperature is below 7°C.
- .4 Remove damaged, dented, defaced, defectively finished or tool marked components and replace with new.
- .5 Refinish shop applied finishes in field only with prior approval from Consultant.
- .6 Clean off dirt on surfaces resulting from installation.

#### 3.3 Schedule of Metal Fabrications

- .1 General
  - .1 Ensure that all Drawings and Specification sections including those for structural, mechanical and electrical work are consulted to establish the limits of metal fabrication installations included in this Section.
- .2 Angle Lintels
  - .1 Supplied by Structural Steel – refer to Structural Drawings.
- .3 Guard Rail
  - .1 Railings and balustrades: round galvanized steel formed to shapes and sizes as detailed on Drawings.
  - .2 Set railing standards in concrete with heated liquid sulphur to fill hole where indicated. Remove overflow immediately.

- .4 Curtain Wall Supports
  - .1 Provide hot-dipped galvanized curtain wall supports at sill of curtain wall, as detailed on Drawings.
    - .1 Sill supports to be 4.8mm thickness.

END OF SECTION

## **PART 1 - GENERAL**

### 1.1 General

- .1 Conform to Division 01 – General Requirements.

### 1.2 Related Sections

- .1 Miscellaneous wood blocking, furring – Divisions 06, 07, 08, 09, 10.

### 1.3 References

- .1 Canadian Standards Association (CSA)
  - .1 CSA B111, Wire Nails, Spikes and Staples.
  - .2 CAN/CSA-G164-M, Hot Dip Galvanizing of Irregularly Shaped Articles.
  - .3 CSA O121-M, Douglas Fir Plywood.
  - .4 CAN/CSA-O141, Softwood Lumber.
  - .5 CSA O151-M, Canadian Softwood Plywood.
  - .6 CAN/CSA-O325.0, Construction Sheathing.
- .2 National Lumber Grades Authority (NLGA)
  - .1 Standard Grading Rules for Canadian Lumber.

### 1.4 Quality Assurance

- .1 Lumber identification: by grade stamp of an agency certified by Canadian Lumber Standards Accreditation Board.
- .2 Plywood identification: by grade mark in accordance with applicable CSA standards.
- .3 Plywood, OSB and wood based composite panel construction sheathing identification: by grademark in accordance with applicable CSA standards.

## **PART 2 - PRODUCTS**

### 2.1 Lumber Material

- .1 Lumber: unless specified otherwise, SPF species softwood, S4S, moisture content 19% or less in accordance with following standards:
  - .1 CAN/CSA O141.
  - .2 NLGA Standard Grading Rules for Canadian Lumber.
- .2 Furring, blocking, nailing strips, grounds, rough bucks, cants, curbs, fascia backing and sleepers:
  - .1 S2S.
  - .2 Board sizes: "Standard" or better grade.
  - .3 Dimension sizes: "Standard" light framing or better grade.

### 2.2 Panel Materials

- .1 Panel standards: type, grade and thickness as indicated, in accordance with following standards:
  - .1 Douglas fir plywood (DFP): to CSA O121, standard construction, exterior grade.
  - .2 Canadian softwood plywood (CSP): to CSA O151, standard construction.
  - .3 Poplar plywood (PP): to CSA O153, standard construction.
  - .4 Waferboard and strandboard: to CAN3-O437.

---

2.3 Pressure Treated Lumber and Plywood

- .1 Pressure treated lumber: to CSA O80.1 - "Preservative Treatment of all Timber Products by Pressure Processes".

2.4 Fasteners

- .1 Nails, spikes and staples: to CSA B111.
- .2 Bolts: 12.7mm diameter unless indicated otherwise, complete with nuts and washers.
- .3 Proprietary fasteners: toggle bolts, expansion shields and lag bolts, screws and lead or inorganic fibre plugs, explosive actuated fastening devices, recommended for purpose by manufacturer.
- .4 Galvanizing: to CSA G164, use galvanized fasteners for exterior work, interior highly humid areas, and pressure-preservative treated lumber.

2.5 Accessories

- .1 Polyethylene film: to CAN 2-51.33 Type 1, 0.15mm thickness.

2.6 Wood Preservative

- .1 Surface applied wood preservative: copper naphthenate or 5% pentachlorophenol solution, water repellent preservative.

**PART 3 - EXECUTION**

3.1 Preparation

- .1 Treat surfaces of material with wood preservative, before installation.
- .2 Apply preservative by dipping, or by brush to completely saturate and maintain wet film on surface for minimum 3 minute soak on lumber and one minute soak on plywood.
- .3 Re-treat surfaces exposed by cutting, trimming or boring with liberal brush application of preservative before installation.
- .4 Treat material as indicated as follows:
  - .1 Wood cants, fascia backing, curbs, nailers, sleepers on roof deck.
  - .2 Wood furring for on outside surface of exterior masonry and concrete walls.

3.2 Installation

- .1 Comply with requirements of NBC, supplemented by the following paragraphs.
- .2 Install furring and blocking as required to space-out and support casework, cabinets, wall and ceiling finishes, facings, fascia, soffit, siding, washroom accessories and other work as required. Install required provisions for fastening located and secured to suit site conditions, and adequate for intended support.
- .3 Align and plumb faces of furring and blocking to tolerance of 1:600.
- .4 Install rough bucks, nailers and linings to rough openings as required to provide backing for frames and other work.
- .5 Except when indicated otherwise, use material at least 38mm thick and secured with 9mm bolts located within 300mm from ends of members and uniformly spaced at 1200mm between.

3.3 Erection

- .1 Frame, anchor, fasten, tie and brace members to provide necessary strength and rigidity.
- .2 Countersink bolts where necessary to provide clearance for other work.

3.4 Schedules

- .1 Provide electrical equipment backboards for mounting electrical equipment as indicated. Use 19mm thick plywood on 19mm x 38mm furring around perimeter and at maximum 300mm intermediate. Paint before installation.

END OF SECTION

---

**PART 1 - GENERAL**

1.1 General

- .1 Conform to Division 01, General Requirements.
- .2 REPORT IN WRITING TO THE WATERLOO REGION DISTRICT SCHOOL BOARD ANY DEFECTS OF SURFACES OR WORK PREPARED BY OTHER TRADES WHICH AFFECT THE QUALITY OR DIMENSIONS OF THIS CONTRACTOR'S WORK SHALL IMPLY COMPLETE ACCEPTANCE OF ALL WORK BY OTHER TRADES OR OF EXISTING ROOM CONDITIONS AND LOCATIONS.

1.2 Reference Standards

- .1 Standard of finished carpentry, metalwork and cabinet work in accordance with the "Millwork Standards" of the Architectural Woodwork Manufacturers Association of Canada (AWMAC).

1.3 Qualifications

- .1 The work of this trade shall be executed by a company having proven first class experience in this type of work and having adequate equipment and skilled personnel.

1.4 Work Included

- .1 Provide all millwork and casework as shown on the drawings, including but not limited to the following: provide prefinished cabinets, display cases, shelving units, counters, vanities, window sills, panelling, wood ceiling systems and similar items where shown on Drawings as specified herein, and as needed for a complete and proper installation.
- .2 Provision of rough hardware, including fastening devices required to secure in place items of carpentry and millwork.
- .3 Supply and installation of finishing hardware for millwork by this millwork contractor section 06 40 00.
- .4 Supply and installation of grilles, etc. on millwork items.
- .5 Installation of all miscellaneous metals for millwork items including but not limited to vanities.
- .6 Supply and installation miscellaneous trims, scribes, filler panels.
- .7 Provide cutouts in the counter tops for the sinks, electrical outlets and all other necessary cutouts regarding the millwork.

1.5 Shop Drawings

- .1 Shop drawings only required where not detailed by "AW" drawing. Copies of "AW" are to be marked up to indicate changes. "AW" drawings refer to WRDSB Millwork Standards drawings contained in Specifications/ Drawings.
- .2 Before shop drawings and fabrication is started, take critical measurements at the site to facilitate installation, fitting of work and access required to move millwork into final location. Take such measurements prior to fabrication of the work of this Section and in ample time to avoid delays in the work.
- .3 Draw Shop Drawings in related and/ or dimensional positions with sections. Scale minimum 1:10.
- .4 Shop Drawings shall show fabrication details, materials, jointing, description of anchorage and hardware.
- .5 Do not commence work until reviewed shop drawings have been returned as approved by Consultant and WRDSB.
- .6 The drawings are to be photocopied, confirmed, to fit openings and sizes, mark up, in red, and returned for approval.

1.6 Delivery and Storage

- .1 Give Painter sufficient notice so that untreated or unprimed carpentry items or materials can be primed immediately upon delivery to site.
- .2 No equipment shall be delivered to the site until portion of the building in which it is to be installed is completely ready for equipment as approved by Consultant.
- .3 Store finished work properly and keep under cover both in transit and at site. Finish woodwork shall not be delivered to site until concrete and masonry work has dried out.
- .4 Cover all plastic laminate and prefinished top surfaces at shop with heavy Kraft Paper.
- .5 Carefully protect from damage of any kind.

1.7 Related Sections

- .1 Section 06 10 10 – Rough Carpentry.
- .2 Section 09 21 16 – Gypsum Board Assemblies.
- .3 Section 09 91 10 – Painting.
- .4 Mechanical – refer to Mechanical Drawings.
- .5 Electrical – refer to Electrical Drawings.

1.8 Shop Finish

- .1 All cabinet work, including wood all other cabinet trims, to be shop finished by this Section and per Section 09 91 10.

1.9 Samples

- .1 Samples melamine 305x305mm, plastic laminate, edging, hinges, pulls, bumpers, drawer slides, and shelf clip.
- .2 Submit duplicate 300mm long samples of each type of moulding.
- .3 Submit samples of construction methods and of all hardware.

1.10 Intent

- .1 The intent of this Section is that casework shall be manufactured and finished at the plant, delivered to the Site and immediately installed by this Section including provision of necessary strapping, backings, bearers, rough hardware and finish hardware and miscellaneous support metals and stainless steel metal components. Touch up finish immediately prior to completion of the Work and leave in perfect condition.

1.11 Cooperation

- .1 Water, drainage and air piping, faucets, hose cocks, retort rod and bases, traps, ventilation ducts, sinks, electric receptacles and wiring are supplied and installed by the Mechanical and Electrical Sections at all rooms. Coordinate the work with these trades and make provision in the construction of the fitments to accommodate this work. Methods of construction shall be such as to permit mechanical and electrical work being concealed in the fitments, cut and frame accordingly, provide removal access panels in the units or provide proper access for installation and repairs.
- .2 Cabinet hardware, pilaster strips, locks, and finishing hardware will be supplied by this Section. Miscellaneous metals used in this section will be supplied and installed by miscellaneous metals contractor unless otherwise noted.
- .3 Woodwork, not shop primed, will be primed and back painted as per painting section immediately upon delivery to the site. Care shall be taken that all surfaces cut after priming are brush coated with an approved primer before installation.

1.12 Maintenance

- .1 Provide Owner with printed instructions for "Care and Maintenance of Plastic Laminate" and millwork finishes.

1.13 Warranty

- .1 Warranty workmanship against manufacturing defects, including warpage or delamination, for a period of five (5) years from date of acceptance of the completed installation. Make good or replace work showing defects in this period, as requested, at no expense to the Owner.

**PART 2 - PRODUCTS**

2.1 Materials

- .1 Finishing Work: Materials used for finish work shall be sound, free from defects that would mar finished appearance, well seasoned and air dried and of good quality for intended purposes. Wood laminates pressure bonded.
- .2 Plywoods:
  - .1 Select Plain Sliced Maple Architectural Grade 'A' No. 1 Face grade; as in compliance with C.S.A. 0115-M1982 with a minimum 5 ply plywood veneer waterproof core, laminated with waterproof adhesive. Plywood shall be good both sides except where concealed by construction. Exposed faces to be natural grade per AWMAC. Interior of doors to be classified as exposed.
- .3 Melamine Faced Particleboard: to CAN3-0.188.1-M78, grade "H" particleboard sanded faces, 13mm, 16mm, 19mm, 28.6mm and 32mm thickness, faced with laminated plastic. Melamine resin impregnated cover sheet with coloured and/or patterned paper inner layer. Melamine shall be thermally fused to rigid particle board substrate. Melamine faces shall be 120 gram weight paper. Colour to be **992 Hardrock Maple (Uniboard)**.
  - .1 Acceptable Material: Flakeboard, Uniboard or approved equal.
- .4 Particleboard: CSA-0118-1975 Type 11, Grade R, minimum 690 K8/m<sup>3</sup>, 4.5 to 8% moisture content.
- .5 Hardwood: shall be selected Hard White Maple, all shall be Architectural Grade (knots will not be accepted). It shall be selected for colours and graining when used for stain work.
- .6 Wood Edging: 6mm hardwood to match plywood unless indicated otherwise (if maple, use hard white maple).
- .7 Melamine Faced Particle Board Edge Banding: solid polyvinylchloride (PVC), 3mm thickness x full width of board, wood core, wood grain type or colour to match melamine face. Edging to be rigid PVC with a measured degree of hardness of "95 shore D" and thickness of "3mm (+0.15mm, -0.2mm)" with the primer side having a concave measuring 0.10 to 0.25mm.  
Edging adhesive: ethylene vinylacetate thermalset adhesive with a temperature resistance of not less than 100°C; A Processing range of 190° - 200°C and natural in colour.  
Edging is to be applied using only equipment designed for the application of thick PVC in strict accordance with the specifications of both the thick PVC and hot-melt adhesive manufactures. All edges and all corners of this 3mm PVC edgebanding are to be machined to a 3mm radius for all cabinet parts.  
Care should be taken during application to achieve the thinnest glue line consistent with a good bond without causing skips or unspread areas. Final colour by Consultant.
- .8 Plywood Concealed by Construction: Douglas Fir plywood shall be veneer core, waterproof, bonded, sanded, complying with C.S.A. 0121-M1978. Solid grade where concealed by construction.

- 
- .9 Concealed Framing Lumber: N.L.G.A.C. select eastern white pine, kiln dried to a 5% moisture content.
- .10 Unexposed Plywood for Framing: Waterproof fir plywood minimum 12.7mm thickness unless indicated otherwise.
- .11 Adhesive:
- .1 Waterproof synthetic resinous glue of approved general type conforming to CSA O112.
  - .2 For plastic laminate - as recommended by plastic laminate manufacturer and to conform to CSA O112.
  - .3 Approved waterproof type.
- .12 Plastic Laminate:
- .1 Laminated Plastic for Flatwork: 1.27mm thick decorative, melamine surfaced, high pressure laminated plastic sheeting in suede finish to conform to CAN3-A172-M79 (R1996) Grade G.P., Type 1. Manufacturer shall thoroughly sand back of sheet to form a homogeneous bonding surface. Plastic laminates shall be as manufactured by Arborite, Formica, Wilsonart or Nevamar. Backing sheet 0.5mm thick, sanded one side. Products may be selected based upon manufacturer's full standard range of colours and patterns. The finish will be suede; the colour will be non-stock.
  - .2 Laminated plastic for postforming work and preforming work: to CAN3-A172-M79 (R1996) Grade P.F., Type 3, 1.25mm thick, based on standard colours with suede finishes as selected by Consultant. Plastic laminates shall be as noted in 1. The colour will be non-stock.
- .13 PVC edging for plastic laminate work: solid polyvinylchloride (PVC), 3mm thickness x full width of board, colour to match plastic laminate face by Canada Wood tape or approved colour equal. Edging to be rigid PVC with a measured degree of hardness of "95 shore D" and thickness of "3mm (+0.15mm, -0.2mm)" with the primer side having a concave measuring 0.10 to 0.25mm.  
Edging adhesive Ethylene vinylacetate thermalset adhesive with a temperature resistance of not less than 100°C; A Processing range of 190° - 200°C and natural in colour.  
Edging is to be applied using only equipment designed for the application of thick PVC in strict accordance with the specifications of both the thick PVC and hot-melt adhesive manufactures. All edges and all corners of this 3mm PVC edgebanding are to be machined to a 3mm radius for all cabinet parts.
- .14 Stainless steel:
- .1 Type 302 or 304 alloy conforming to ASTM A167, No. 4 finish, 1.59mm (16ga) thick, suitable for lamination to veneer core plywood, back surface with special lacquer coating to prevent chemical interaction of the stainless steel and laminating adhesive.
- .15 Nails and Staples: To C.S.A. Bill-1974. Use spiral threaded nails and barbed staples.
- .16 Architectural Woodwork Finish: Refer to Section 09 91 10.
- .17 Shelves: adjustable shelves longer than 950mm and fixed shelves without centre supports longer than 950mm to be 28.6mm thick wood veneer plywood or melamine faced particleboard as detailed. Shelves shorter than lengths specified above are to be 19mm thick wood veneer plywood core and melamine faced particleboard for alternate price items. Front edges of adjustable shelves to be edge-banded. Front edges of fixed shelves to edge banded, rear edge to be secured to cabinet back panel.
- .18 Exposed Fasteners: All millwork units secured to walls shall be secured with Tapcon screws and cup washers. All specialty fasteners such as acorn head bolts shall be supplied and installed by this section. Submit samples for Consultant's approval.
- .19 Aluminum Grilles: Brush finished aluminum size as indicated on Drawings. **Supply and installation of grilles, etc. by this Section.**
- .20 Countertops: to be to be stainless steel on veneer core waterproof plywood or plastic laminate postformed on particleboard or veneer core plywood or as noted on the Drawings. Adhesives: to CSA 0112.5M, waterproof type. Counter tops are postformed D profile.

- .21 Backer standard: to be 0.028 thick. Panels shown to have backer panel shall be balanced with 0.5mm backing sheet manufactured by the same manufacturer as the facing sheet. Core CSA O115-M1982 (R2001) (G/SO) or CSA O121-17 Grade "B" or CSA CAN3-O188.1-M78, Grade R.

## 2.2 Hardware

- .1 The cabinet work manufacturer shall furnish and install cabinet hardware. Finish of hardware shall be used US26D or US28 depending on base material. Hardware shall be manufactured as follows or approved equal:
- .1 Pulls - door and drawer, Canadian Building Hardware CBH 255 x C26D.
  - .2 Hinges - Blum model 170BL91-653 with Blum mounting plate BL175.810 or approved equal, or specified other on Drawings. Or Hafela Aximat hinges self-closing 270° if noted on Drawings.
  - .3 Cabinet locks door and drawer - National # C8053-5 or approved equal. All cupboard doors in a room to be keyed the same. Each room to be keyed different. Provide 6 master keys for cupboard locks.
  - .4 Shelf support - Richelieu - # 5834-180 for 32mm spaced holes in all gables or recessed pilaster strips see drawings.
  - .5 Door Bumper - Richelieu # AMP5312-11.
  - .6 Elbow Catch - Richelieu # BP3675-2G.
  - .7 Toe Kick Vent - Richelieu # 010533-30.
  - .8 Drawer slides - Blum Metabox 320M integrated runner system using epoxy steel carcasses, adjustable front fixing brackets and 12mm Melamine with 3mm PVC on all exposed edges for bottoms and back panels. Install screws to all pre-drilled holes. Use deepest Metabox possible for space available or approved equal. See Drawings for other slides called for specific locations.
  - .9 Rough Hardware - Nails, screws, bolts, lag screws, anchors, special fastening devices and supports required for erection of carpentry components. Use galvanized components if exposed to exterior atmosphere. Galvanize in accordance with the requirements of CSAG164-M1981. Install all hardware to manufacturer specifications.
  - .10 Slide Bolts: Gallery 73 - 75mm or approved equal.
  - .11 Closet rod: Metal rod chrome 26mm dia. #122.108.140 and matching flanges #8332-140, by Richelieu
  - .12 Coat Hooks: Henkel Hook from Henkel Diversified Inc (519-641-5872).

## 2.3 Fabrication

- .1 General
- .1 Fitments shall be machined, assembled in mill where possible and delivered to job in units. Construct in accordance with details using first class cabinet construction with joints dowelled, glued and properly fastened. Machine all surfaces of finished woodwork to an even smooth surface; fit all joints and miters accurately. Frame materials with tight joints held in place. Conceal joints and connections where possible. Joints made on site shall be equal in quality of work to joints made in the shop.
  - .2 Check job dimensions and conditions and notify the Consultant in writing of unacceptable conditions. Design construction methods for expansion. Do not proceed until remedial instructions are received.
  - .3 Deliver work to the job ready for installation. Leave ample allowance for fitting and scribing on the job. Shop assemble work for delivery to site in size easily handled and to ensure passage through building openings, Design units to fit together if site assembly is required.
  - .4 Fabricate work square and to the required lines. Recess and conceal fasteners and anchor heads. Fill with matching wood plugs.

- 
- .5 Comply with glue manufacturer's recommendations for lumber moisture content, glue life, pot life, working life, mixing spreading, assembly time, time under pressure and ambient temperature.
  - .6 The interior of counters, cupboards, shelving units, desks, shall be considered "exposed". Finish all exposed edges with 3mm thick PVC edge banding material, applied by an Edge-Bander using Hot Melt adhesive. Colour to match the melamine. Radius all exposed edges and corners (PVC edging or Wood edging). Counter tops which are to receive plastic laminate coverings may be 3/4" (19mm) thick sanded veneer core plywood where specified. Particle core shall be used for shelving and gables, countertops specifically called for as solid material or as otherwise specified. Include all filler strips and to match the face colour.
  - .7 Refer to Drawings and Architectural Detail Sheets for location, details, number of units required and location of fittings.
  - .8 Interior fitments shall be complete in every respect with special fittings required and hardware.
  - .9 Provide exposed end grain of solid members and edges of exposed plywood with matching solid hardwood edging at least 6mm thick and thicker where specified. At melamine faced particle board provide 3mm P.V.C. edging complete with 3 mm radius on all exposed edges and corners as per millwork sections. Edging to melamine faced particle board shall be applied with an Edge-Bander using hot melt adhesive.
  - .10 Make all necessary cut-outs in the furniture for sinks, gas cocks, appliances, and electrical switch and outlet boxes and pre-drill all mounting holes for faucets, fittings and outlet boxes. Refer to electrical and mechanical drawings and specifications.
  - .11 Provide and install pipe covers, scribing pieces, top, bottom and/or closures and filler panels where necessary, including wherever units require furring out or blocking to existing conduits, pipes, etc.
  - .12 Service cover panels to be provided at all kneehole drawer units, kneehole front rails and knee drawer table assemblies. End closing panels to be provided at all exposed ends of service strips and island/peninsula assemblies. Front filler panels to be provided where called for on Drawings and as required by field conditions.
  - .13 Telephone and electrical receptacles and wiring are specified under Electrical Division. Coordinate work of this trade, make provision to accommodate this work and cut tops for and provide wood bearers for support.
  - .14 Cooperate with others engaged in work on the building to the end that proper unity of action will assure the orderly progress of the work. Do necessary boxing and protecting of sills, jambs, and the like. Construct scaffold, ramps, and other temporary staging necessary.
  - .15 Provide 19mm plywood adjustable or fixed shelving where detailed. Maximum unsupported span for shelving shall be 900mm. Fixed shelves shall be dowelled into gables and divisions. Where shelves are set on clips only, gables shall be drilled 32mm o.c. for total height of gables.
  - .16 The plywood used in interior fitments throughout regardless of whether for paint or stain finish, shall have exposed edges edged with solid strips 6mm wide, unless noted otherwise by full thickness of plywood. No exposed edges of plywood will be permitted. Strips shall be glued and accurately fixed to edges. Adjustable shelves shall have strips applied to front edge.
  - .17 Exposed framing members and trim shall be solid hard maple.
  - .18 Plastic laminate coverings to fitments, cupboards and counters shall be in colours selected by Consultant and applied in accordance with manufacturer's directions. Where plastic laminate occurs, exposed edges and edges around cut-outs such as sinks shall be edged in the same material. Seal remaining exposed edges of surfaces with heavy Kraft paper prior to shipment. Paper shall not be removed

- until final cleaning. When cutting holes in plastic laminate work, corners shall be rounded and filed smooth.
- .19 When cutting holes in plastic laminate work, corners shall be rounded and filed smooth.
- .20 Protection erected by this trade shall be removed, damage to this work and adjoining work due to the lack or failure of such protection, made good and debris, surplus materials, plant and equipment removed and premises and the whole left clean and tidy to Consultant's satisfaction.
- .21 Melamine on all surfaces unless noted otherwise.
- .22 Fabricate all plywood and melamine faced particle board backs, gables and bottoms of millwork units together by means of 8mm x 25mm hardwood dowels or with hardwood biscuits. All backs to be 12.7mm stock. Dowel all panel cabinet components using 5mm x 25mm hardwood dowels or biscuits at maximum 100mm o.c. All drawer bottoms and backs are 12.7mm stock or greater. All exposed edges on all melamine faced particle board units to be edged with solid 3mm PVC C/W 3mm radius edges and corners including drawer parts and with 6mm matching hardwood edge banding at Maple and Birch units. Kick material for normal application shall be 19mm waterproof spruce/fir plywood to be used. Resilient base by Section 09 65 16 and porcelain tile base by Section 09 30 15.
- .2 Counters, Cupboards, Shelving etc.
- .1 Adjustable shelves c/w clips and drilled holes at 32mm centers. Base cabinet's c/w 1 shelf, wall cabinet's c/w 2 shelves, and tall cabinet's c/w 5 shelves, the centre shelf is fixed unless Drawings show otherwise. Factory install all hardware firmly into position for long life under hard use. Install 2 hinges on doors up to 1 metre in height, 3 hinges to 1.5 metre in height and 4 hinges for doors greater than 1.5 metres in height or shown otherwise.
- .2 Frame as detailed with 19mm thick, or as noted otherwise, plywood gables, tops and bottoms. House intermediate dividers and plywood backs, into gables and top and bottom shelves, for all fitments. Plywood shall be birch or oak as called for in this Section unless otherwise indicated. Cabinet backs to be 12.7mm plywood.
- .3 Where melamine specified: horizontal and vertical gables; and shelving to be 19mm particle core with melamine, good 2 sides. Cabinet backs to be 13mm particle core with melamine, good 1 side.
- .4 Fabricate cabinet carcass, the 32-millimeter system from 19mm thick melamine composite panel using flush frameless construction and exposed edges, to AWMAC Standard " Custom grade" c/w 3mm thick PVC edge banding on exposed edges. All exposed edge banding c/w 3mm radiuses edges and corners. Do not exceed 800mm a maximum width of cabinet without a divider or specified otherwise.  
Carcass construction- Backs 16mm, bottoms, rails, doors, drawer fronts 19mm of melamine composite panels, assembled with glued hardwood dowels 8x30mm or wafers.
- .5 Cut countertops for sinks and provide bearers. Provide backsplash at back of sink for entire length of the unit and at return ends where walls or other vertical surface occur within 600mm of sink or other wet location.
- .6 Countertop and backsplash will be plastic laminate unless noted otherwise.
- .7 Provide removable plywood access panels, screwed in place, where necessary for access to concealed wiring.
- .8 Fit trim and scribe moulds to fitments as shown and as required to hide voids at walls, partitions and ceilings.
- .9 Provide cut-outs for inserts, outlets, grilles, appliances, etc. occurring in fitments.
- .10 Bottom of units blocked up to form a 100mm high x 75mm deep toe space and fabricated from 19mm waterproof veneer core plywood of fir or spruce
- .11 Fit fillers between fitments, of same material as fitments, where necessary to fill voids between fitments and walls.

- .12 Lighting fixtures and outlets to be supplied and installed under Division 26.
- .13 Provide cutouts and access panels where required for Divisions 22-23 and covers over ductwork (stove exhaust fans) or piping that run exposed above counters and upper shelves.
- .14 Provide extended top, bottom, and exposed gables where furring out of upper cupboards is required due to pipes, conduits, and the like behind to provide a flush face at walls.
- .15 Plastic Laminate Work:
  - .1 Comply with CAN3-A172-M79, Appendix "A".
  - .2 Veneer laminated plastic to core material in accordance with adhesive manufacturer's instructions. Ensure core and laminate profiles coincide to provide continuous support and bond over entire surface. Provide cores of not less than 19mm nominal thickness solid face Douglas Fir.
  - .3 Form shaped profiles and bends as indicated, using postforming grade laminate to laminate manufacturer's instructions.
  - .4 Use straight self-edging laminate strip 1.6mm thick for flatwork to cover exposed edge of core material. Chamfer exposed edges uniformly at approximately 20°. Do not mitre laminate edges. Curved self edging shall be postformed material or bending grade.
  - .5 Apply laminate backing sheet to reverse side of core of plastic laminate work where specified. Provide backing sheet of sufficient thickness to compensate for stresses caused by the facing sheet.
  - .6 Locate joints where indicated, where not indicated at approximately 2440mm or 3660mm centres also include joints at corners, and changes in superficial area.
  - .7 Accurately fit decorative laminate together to provide tight, flush, butt joints. Joints in cored panels shall be made with 6mm blind splines and draw bolts, one draw bolt for widths up to 150mm two or more draw bolts at maximum 450mm o.c. for widths exceeding 150mm.
  - .8 Keep joints min. 600mm from sink cutouts.
  - .9 Seal the core at joints and exposed edges with sealer.
  - .10 Counter tops apply Tremco Tremsil 200 silicone sealant at junction of plastic laminate or phenolic tops when tops are joined. All joints to be over a gable or supported otherwise.
  - .11 Use draw bolts in counter top joints.
  - .12 Apply a small bead of mildew-resistant paintable silicone sealant at junction of plastic laminate counter back and adjacent wall finish.

### **PART 3 - EXECUTION**

#### **3.1 Workmanship**

- .1 Fabricate and install work in accordance with the best practice. Finished work shall be free from drag, feathers, slivers or roughness of any kind. Remove machine marks by sanding. Give finished work smooth surfaces, ready for painting or varnish application.
- .2 Mortise and tenon joints shall be glued and pinned. All panels shall be secured together with specified glued and dowelled method. Glue blind screw all fabricated component work unless otherwise specified. Set surface nails and plug countersunk screws with matching wood plugs. Use screws with cap washers where units with doors are secured to walls behind.
- .3 Finished woodwork shall be free from bruises, blemishes, mineral marks, knots, shakes and other defects.
- .4 All metal items such as grilles, tracks, supports, legs, brackets, etc. supplied by other trades shall be built into fitments, panelling, wood doors, etc., in strict accordance with directions of trades supplying such.

- .5 Furnish rough hardware, nails, expansion shields, screws, brackets and incidentals required to assemble and install the fitments in their proper locations.
- .6 Fit small scribe moulds or fillers of same materials as fitment to hide or fill voids at walls, partitions ceilings, furrings, exposed tops of millwork units, at base locations where rubber base occurs.
- .7 Plywood Edging: all exposed 19mm plywood edges shall be covered with glued on 6mm thick hardwood strips.

### 3.2 Millwork Workmanship

- .1 Fitments shall have joints dowelled and all joints shall be glued and nailed or screwed. All cabinet bases shall be of 19mm plywood, blocked at 900mm O.C. maximum and at corners.
- .2 Counter tops shall have splash backs where sinks occur.
- .3 Shelving shall be 19mm plywood, adjustable or fixed as detailed. Maximum unsupported span for shelving shall be 900mm. Adjustable shelves shall be set on angle clips or metal pilaster strips. Loose shelves shall have PVC edges on front edge.
- .4 Laminates shall be pressure bonded to back-up board. Counter tops shall be self edged and have plastic laminate covered back splash. Back-up material for counter tops shall be particle core unless otherwise noted.
- .5 Plastic laminate surface shall be level, without bubbles and core ghosting. Core edges in counter cut outs shall be sealed with asphalt compound. All exposed plastic edges shall be matched and sanded.

### 3.3 Installation

- .1 Commencement of work implies total acceptance of surface and site conditions.
- .2 Set and secure all materials and components in place, rigid plumb and square.
- .3 Provide all furring strips and strapping required fixing millwork and casework to walls, etc.
- .4 Provide all filler strips to seal any openings or joints at adjacent surfaces.
- .5 After installation, fit and adjust operating hardware to align all doors and drawers.
- .6 Clean up as the work proceeds and upon completion remove all rubbish and surplus materials resulting from the foregoing work.
- .7 Plumbing
  - .1 Sink installation:
    - .1 Cut hole, clean the counter top with alcohol.
    - .2 Use Tremco, Tremsil #200 a silicone sealant that gives protection against fungi and bacteria.
    - .3 Install Tremsil around the cuts, and then place a bead of Tremsil on the top before installing the sink.
    - .4 Millwork Contractor to ensure the Plumber installs as specified.
- .8 Installation and assembly work on the job shall be executed by skilled forces under supervision of a competent joinery foreman.
- .9 Furnish rough hardware, nails, expansion shields, screws, brackets and incidentals required to assemble and install fitments in proper locations. Units shall be adequately fastened and secured in place with concealed fixings wherever possible. Include grounds and furring where required.
- .10 Fitments shall be installed level, plumb and true and complete in all respects.
- .11 Provide smooth surfaces with fastenings sunk and filled over to receive stain and sealer.
- .12 Use draw bolts in countertop joints.
- .13 At junction of plastic laminate counter, back splash and adjacent wall finish, apply small bead of silicone sealant as per Section 07 92 10 in colour as selected by Consultant.
- .14 Apply water resistant building paper over wood framing members in contact with masonry or cementitious construction.

3.4 Resilient Base

- .1 Supply and installation of resilient base at millwork units as indicated is by Section 09 65 16 for rubber base locations.

END OF SECTION

# ELEVATIONS / SECTIONS

## MATERIAL LEGEND:

### MATERIALS LEGEND

- ① DISPLAY CASE
- ② 100 HIGH RUBBER BASE TOE KICK ON 19 VENEER CORE PLYWOOD
- ③ 19mm MELAMINE PANEL OPEN STORAGE c/w 5 ADJUSTABLE SHELVES
- ④ 19mm MELAMINE PANEL DRAWER FRONT c/w 3mm PVC EDGES. REFER TO SPEC FOR DRAWER SLIDERS AND DRAWER CONSTRUCTION (METABOX)
- ⑤ 19mm MELAMINE GABLE PANEL c/w 3mm PVC ON ALL EXPOSED EDGES AND PIN HOLES FOR 19mm ADJUSTABLE SHELVES AS SHOWN
- ⑥ 19mm MELAMINE PANEL BANK OF 4 DRAWERS
- ⑦ POST FORMED PLASTIC LAMINATE COUNTERTOP c/w 76 HIGH BACKSPLASH ON STOCK
- ⑧ GYPSUM BOARD BULKHEAD
- ⑨ 19mm MELAMINE PANEL UPPER CABINETS c/w FINISHED END GABLES WHERE REQUIRED AND ADJUSTABLE SHELVES AS SHOWN
- ⑩ 80 HIGH MELAMINE PANEL VALANCE x 19mm
- ⑪ STAINLESS STEEL SINGLE SINK
- ⑫ PLASTIC LAMINATE SEPARATE BACKSPLASH ON 19mm PLYWOOD
- ⑬ 19mm MELAMINE COUNTERTOP C/W 3mm PVC ON ALL EXPOSED EDGES AND BETWEEN BUTT JOINT EDGES
- ⑭ DISHWASHER
- ⑮ 19mm MELAMINE ADJUSTABLE SHELF WITH 3mm PVC EDGES
- ⑯ 16mm MELAMINE BACK c/w 3mm PVC EDGE WHERE EXPOSED
- ⑰ 19mm MELAMINE TOP, BOTTOM c/w 3mm PVC EDGE
- ⑱ ENAMELED STEEL VANITY LAVATORY
- ⑲ LOCKABLE CASTERS REFER TO SPEC.
- ⑳ PLASTIC LAMINATE POST FORMED WORK SURFACE ON MELAMINE PANEL INTERMEDIATE GABLES
- ㉑ PLASTIC LAMINATE POST FORMED COUNTERTOP AND MELAMINE PANEL OPEN STORAGE c/w FINISHED GABLE END WHERE REQUIRED AND ADJUSTABLE SHELVES AS SHOWN
- ㉒ 19mm MELAMINE FIXED SHELF c/w 3mm PVC EDGE
- ㉓ 19mm MELAMINE DOOR c/w 3mm PVC EDGE ON ALL EXPOSED EDGES
- ㉔ 19mm MELAMINE PANEL c/w 3mm PVC EDGE ON ALL EXPOSED EDGES
- ㉕ 16mm MELAMINE PANEL c/w 3mm PVC EDGE ON ALL EXPOSED EDGES FRAME
- ㉖ 16mm FIXED MELAMINE PANEL/SHELF c/w 3mm PVC EDGE ON ALL EXPOSED EDGES
- ㉗ PLASTIC LAMINATE POST FORMED COUNTERTOP AND MELAMINE PANEL GABLES
- ㉘ PLASTIC LAMINATE ON 19mm PLYWOOD
- ㉙ 25mm MELAMINE WITH PVC EDGE AT FRONT FACE AND EACH FACE OF THE JOINTS IN THE COUNTER TOP
- ㉚ 38mm X 89mm SOLID HARDWOOD SUPPORT
- ㉛ SINGLE 19mm MELAMINE GABLE C/W 1/8" PVC EDGE
- ㉜ TRIPLE 19mm MELAMINE GABLE SUPPORT C/W 3mm PVC EDGE ON FRONT AND FLOOR EDGE AT APPROX. 910mm O.C. MAX. WAFER AND SCREW TOGETHER.
- ㉝ ADJUSTABLE FEET SEE SPEC.
- ㉞ 51mm X 102mm OR 19mm PLYWOOD CONTINUOUS BLOCKING ON WALL, PROVIDE WOOD BLOCKING AT ALL EDGE END WALL CONDITIONS.
- ㉟ 19mm HARDWOOD SCREW STRIP BETWEEN MELAMINE GABLES.
- ㊱ PLYWOOD PANEL FILLER 19mm
- ㊲ 19mm VENEER CORE PLYWOOD CONTINUOUS JOINTS TO BE AT GABLE LOCATIONS.
- ㊳ TEMPERED GLASS PANEL FILLER IN 19mm MELAMINE DOOR c/w 3mm PVC EDGE ON ALL EXPOSED EDGES

# Waterloo-Oxford District Secondary School

1206 Snyder's Rd W, Baden, ON N3A 1A4)OW REPLACEMENTS, INTERIOR ALTERATIONS AND HVAC UPGRADES

Project No.:

1167A

MILLWORK LEGEND

Plot Date:

2026-03-26

**CORNERSTONE**  
ARCHITECTURE

102-320 Thamees St. London ON Canada N6A 0E1  
P 519 432 6644 F 519 432 6737  
cornerstonearchitecture.ca

© 2025 Cornerstone Architecture Incorporated. All Rights Reserved.

**AW001**

COORDINATE w/ M&E SHOP DRAWINGS  
FOR EQUIPMENT SIZES AND ROUGH-INS

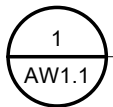
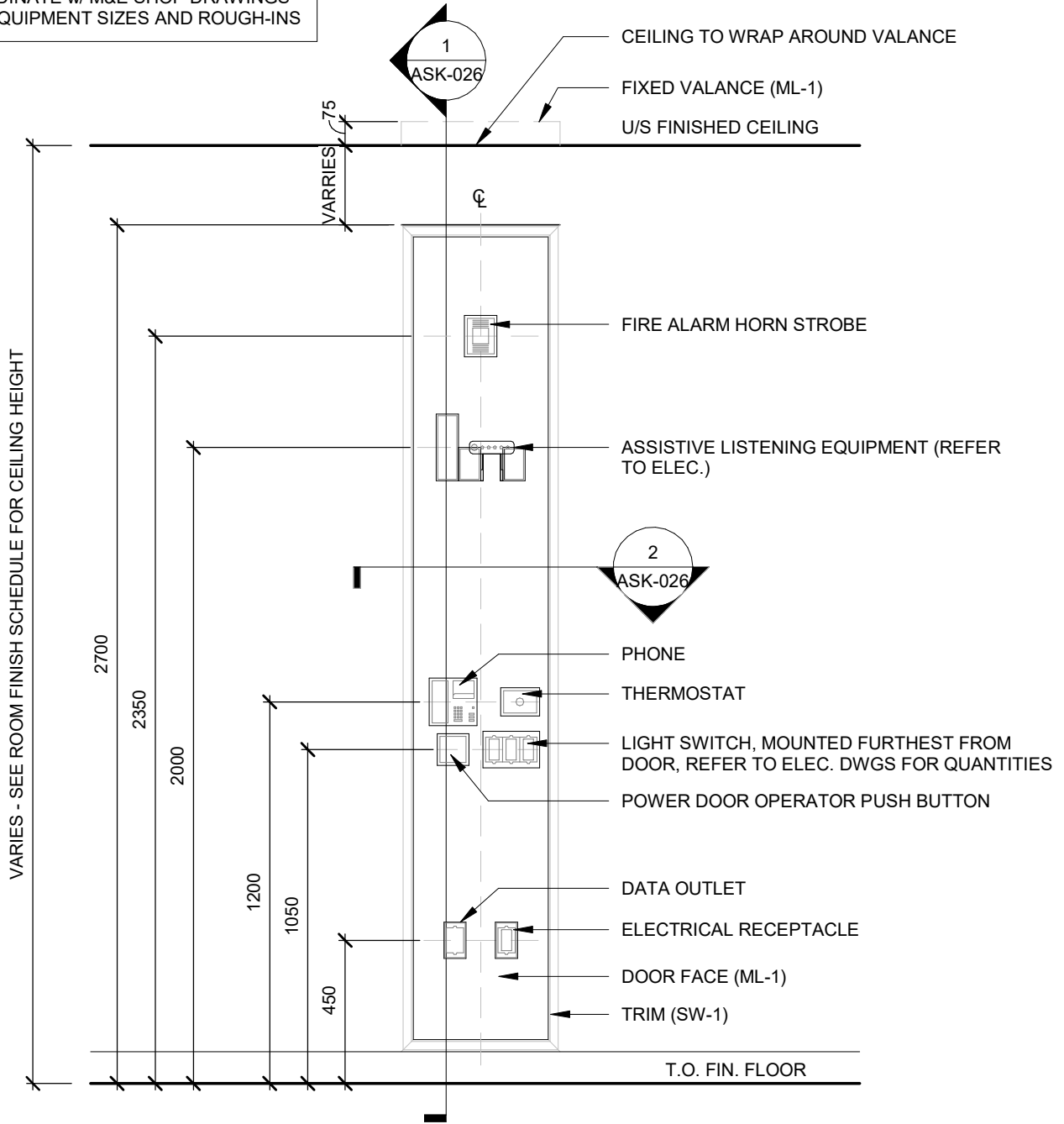

ELEVATION

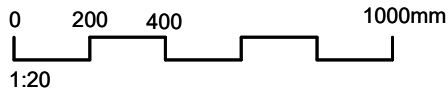

# Waterloo-Oxford District Secondary School

1206 Snyder's Rd W, Baden, ON N3A 1A4)OW REPLACEMENTS, INTERIOR ALTERATIONS AND HVAC UPGRADES

Project No.:

1167A

CONSOLE UNIT - ELEVATION

Plot Date:

2026-03-26

**CORNERSTONE**  
ARCHITECTURE

102-320 Thamees St. London ON Canada N6A 0E1  
P 519 432 6644 F 519 432 6737  
cornerstonearchitecture.ca

AW1.1

© 2025 Cornerstone Architecture Incorporated. All Rights Reserved.

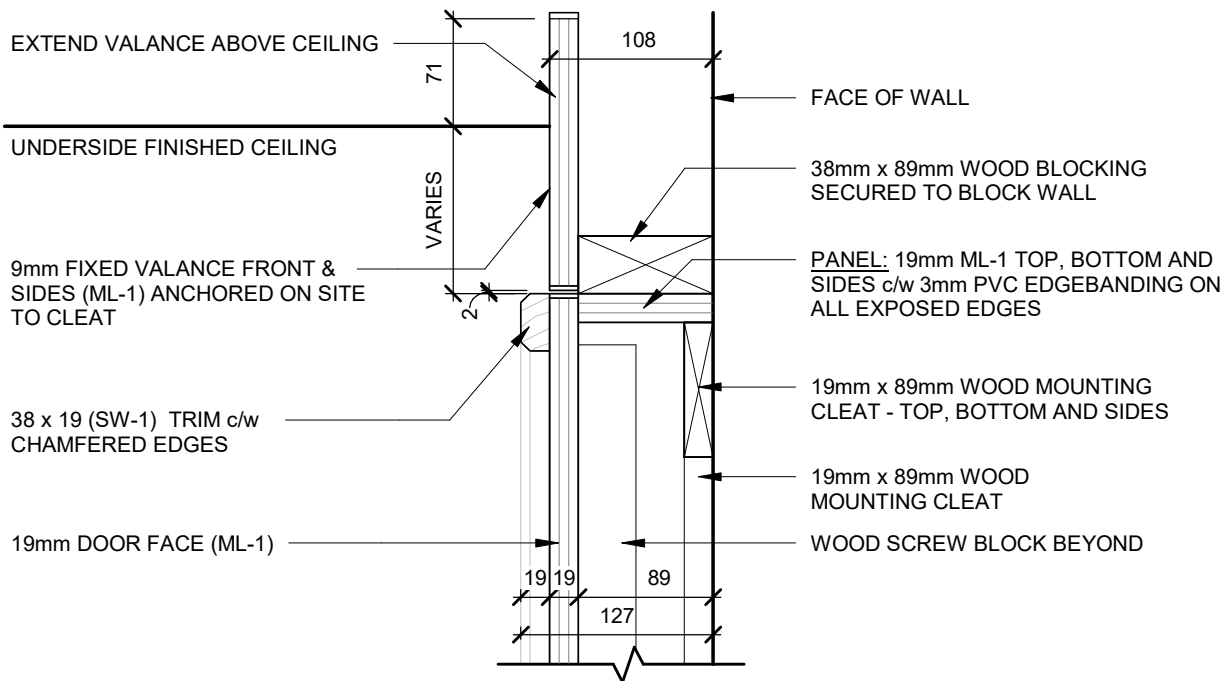

1  
AW1.2

SECTION DETAIL

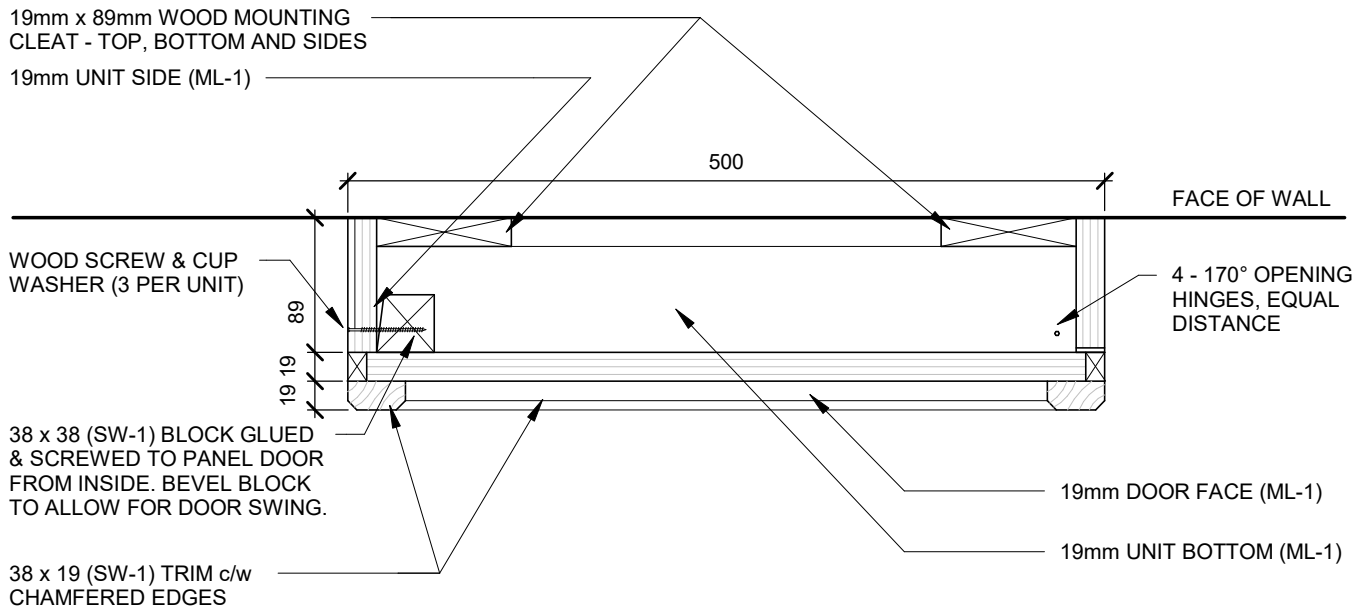
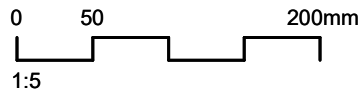

2  
AW1.2

PLAN DETAIL

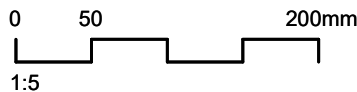

# Waterloo-Oxford District Secondary School

1206 Snyder's Rd W, Baden, ON N3A 1A4)OW REPLACEMENTS, INTERIOR ALTERATIONS AND HVAC UPGRADES

Project No.:

1167A

CONSOLE UNIT - DETAILS

Plot Date:

2026-03-26

**CORNERSTONE**  
ARCHITECTURE

102-320 Thamees St. London ON Canada N6A 0E1  
P 519 432 6644 F 519 432 6737  
cornerstonearchitecture.ca

AW1.2

© 2025 Cornerstone Architecture Incorporated. All Rights Reserved.

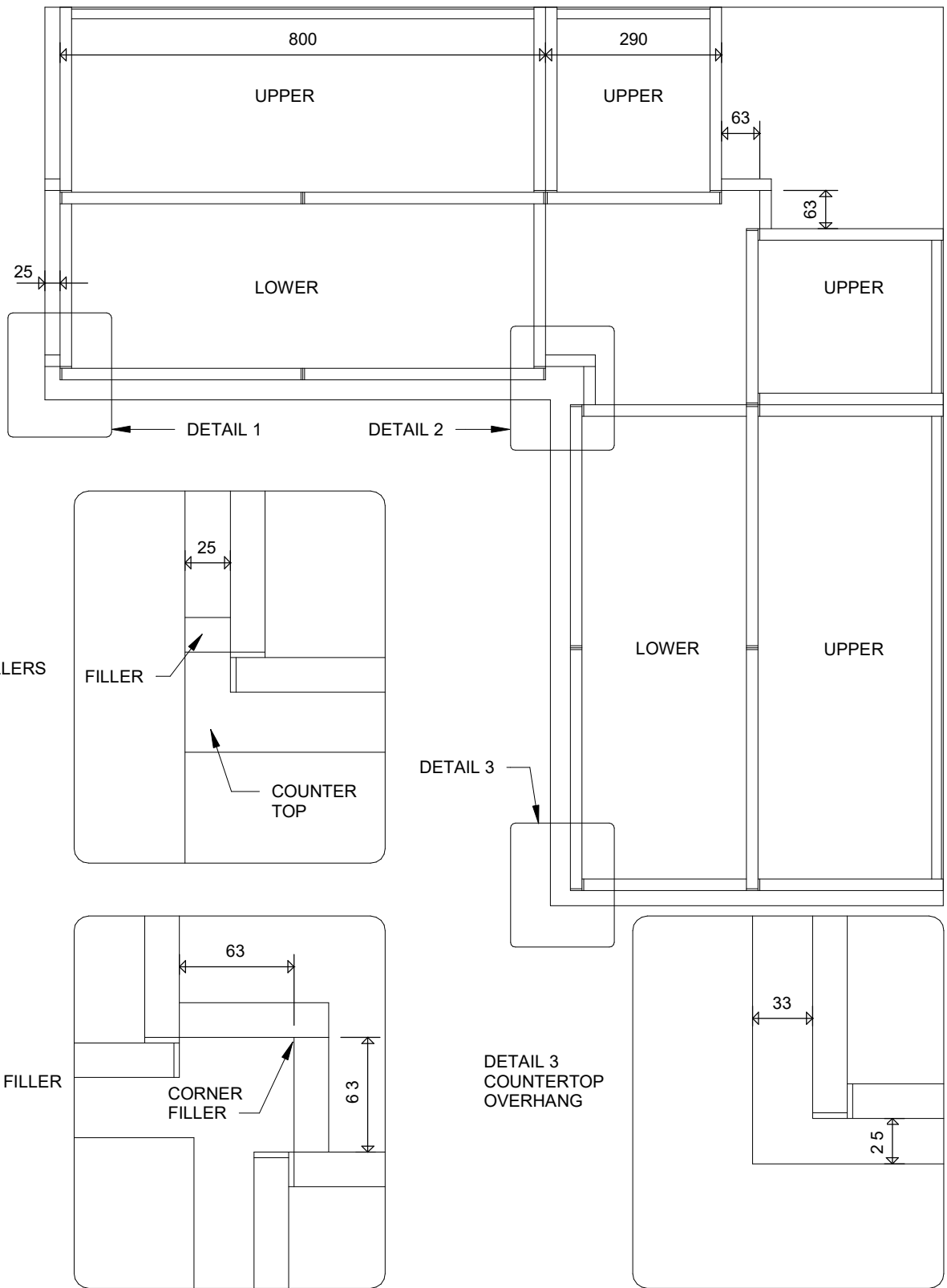

DETAIL 1  
WALL FILLERS

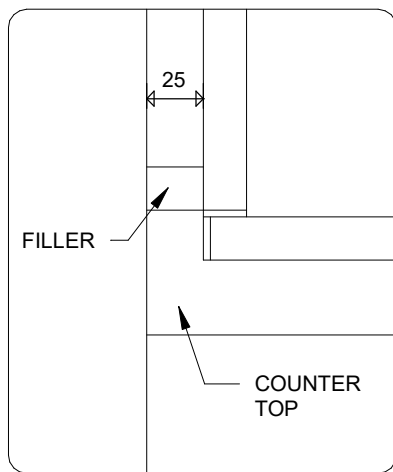

DETAIL 3

DETAIL 3  
COUNTERTOP  
OVERHANG

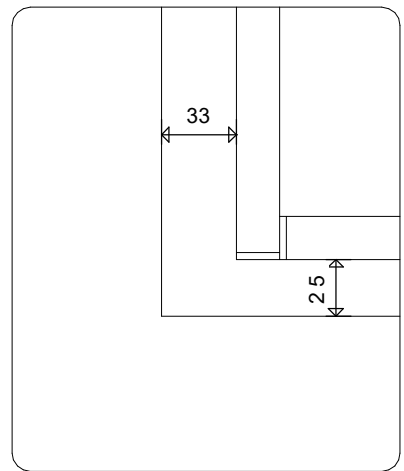

DETAIL 2  
CORNER FILLER

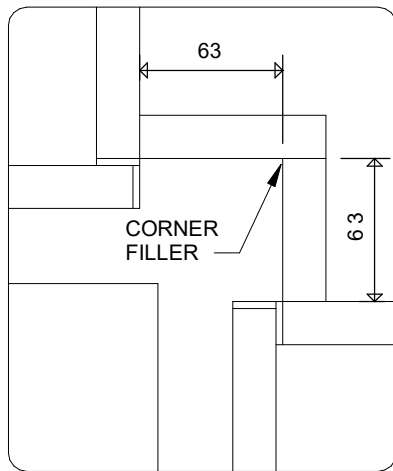

# Waterloo-Oxford District Secondary School

1206 Snyder's Rd W, Baden, ON N3A 1A4)OW REPLACEMENTS, INTERIOR ALTERATIONS AND HVAC UPGRADES

TYPICAL FILLERS AND COUNTER OVERHANG

Project No.:

1167A

Plot Date:

2026-03-26

**CORNERSTONE**  
ARCHITECTURE

102-320 Thamees St. London ON Canada N6A 0E1  
P 519 432 6644 F 519 432 6737  
cornerstonearchitecture.ca

© 2025 Cornerstone Architecture Incorporated. All Rights Reserved.

**AW002**

SAMPLE SETBACKS OF PANELS  
AND SHELVES (STEPPED TO  
MATCH PVC EDGING)

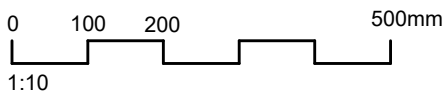
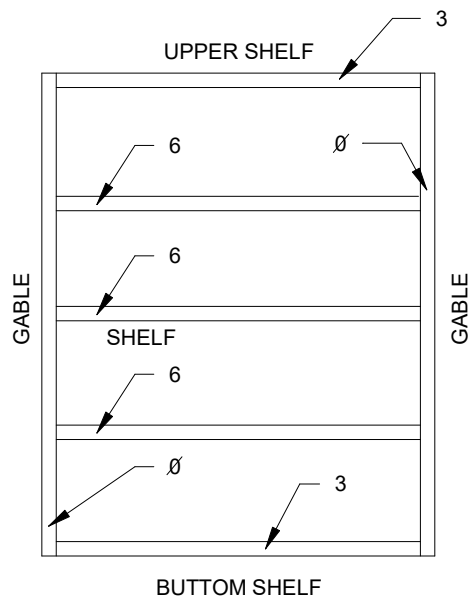
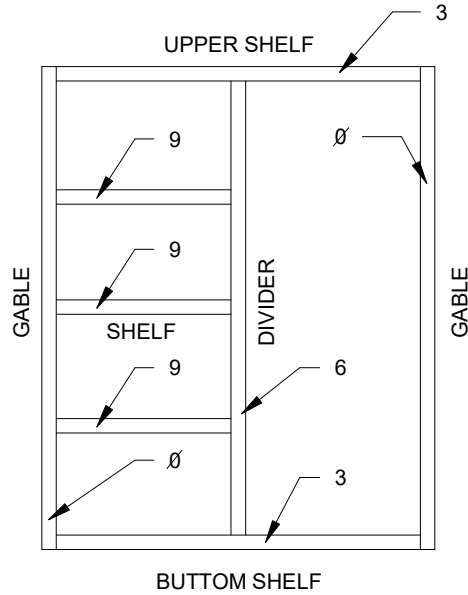

# Waterloo-Oxford District Secondary School

1206 Snyder's Rd W, Baden, ON N3A 1A4

WINDOW REPLACEMENTS, INTERIOR ALTERATIONS  
AND HVAC UPGRADES

Project No.:

1167A

TYPICAL SHELF AND GABLE SETBACKS

Plot Date:

2026-03-26

**CORNERSTONE**  
ARCHITECTURE **E**

102-320 Thamees St. London ON Canada N6A 0E1  
P 519 432 6644 F 519 432 6737  
cornerstonearchitecture.ca

**AW003**

© 2025 Cornerstone Architecture Incorporated. All Rights Reserved.

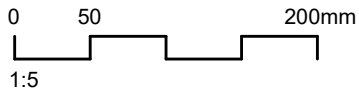
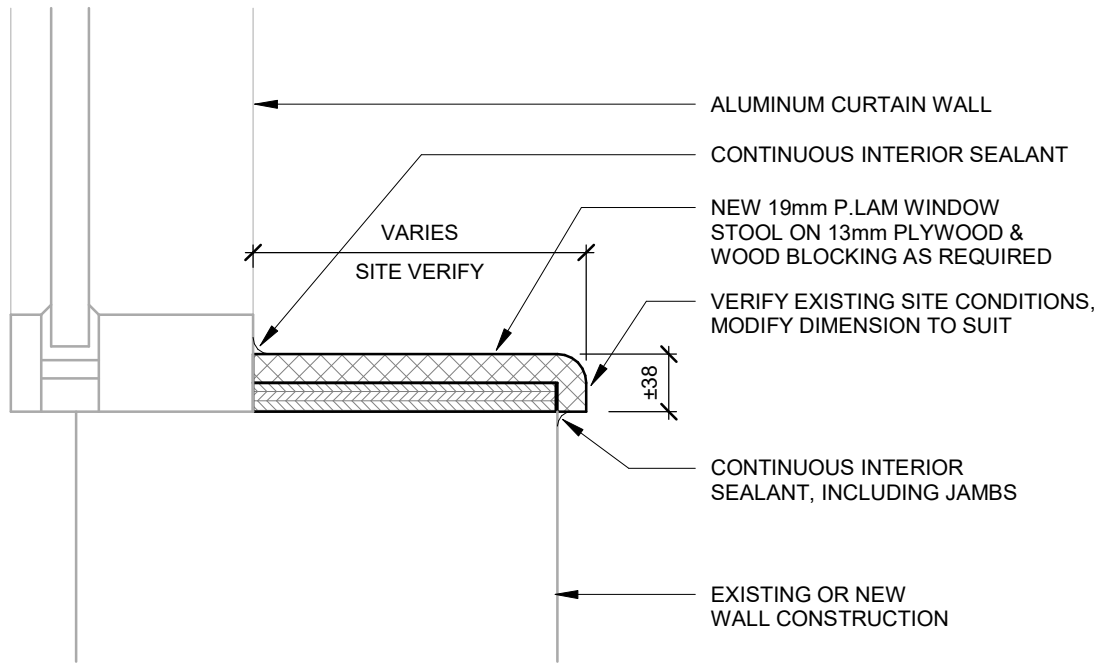

# Waterloo-Oxford District Secondary School

1206 Snyder's Rd W, Baden, ON N3A 1A4)OW REPLACEMENTS, INTERIOR ALTERATIONS AND HVAC UPGRADES

Project No.:

1167A

TYPICAL WINDOW STOOL MILLWORK DETAIL

Plot Date:

2026-03-26

**CORNERSTONE**  
ARCHITECTURE

102-320 Thamees St. London ON Canada N6A 0E1  
P 519 432 6644 F 519 432 6737  
cornerstonearchitecture.ca

**AW004**

© 2025 Cornerstone Architecture Incorporated. All Rights Reserved.

39mm SPACET WITH FLUSH  
TOP CONTINUOUS TO WALL

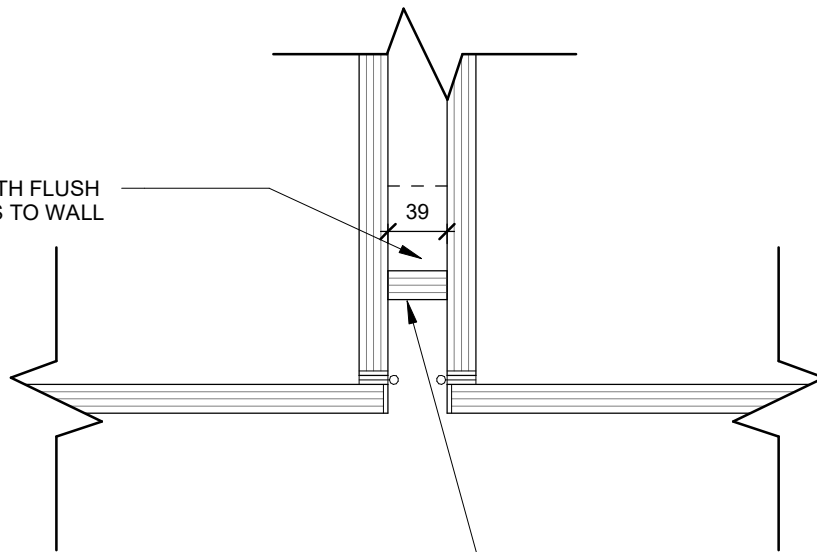

39mm SPACER SETBACK 50mm  
FROM HINGES c/w 3mm PVC  
EDGING ON EXPOSED EDGES

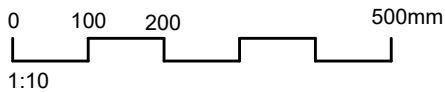

# Waterloo-Oxford District Secondary School

1206 Snyder's Rd W, Baden, ON N3A 1A4)OW REPLACEMENTS, INTERIOR ALTERATIONS AND HVAC UPGRADES

Project No.:

1167A

TEACHERS CLOSET SPACER DETAIL

Plot Date:

2026-03-26

**CORNERSTONE**  
ARCHITECTURE

102-320 Thamees St. London ON Canada N6A 0E1  
P 519 432 6644 F 519 432 6737  
cornerstonearchitecture.ca

**AW009**

© 2025 Cornerstone Architecture Incorporated. All Rights Reserved.

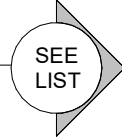

AW202  
AW202A

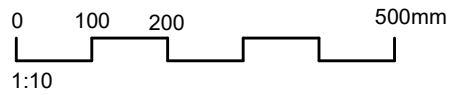
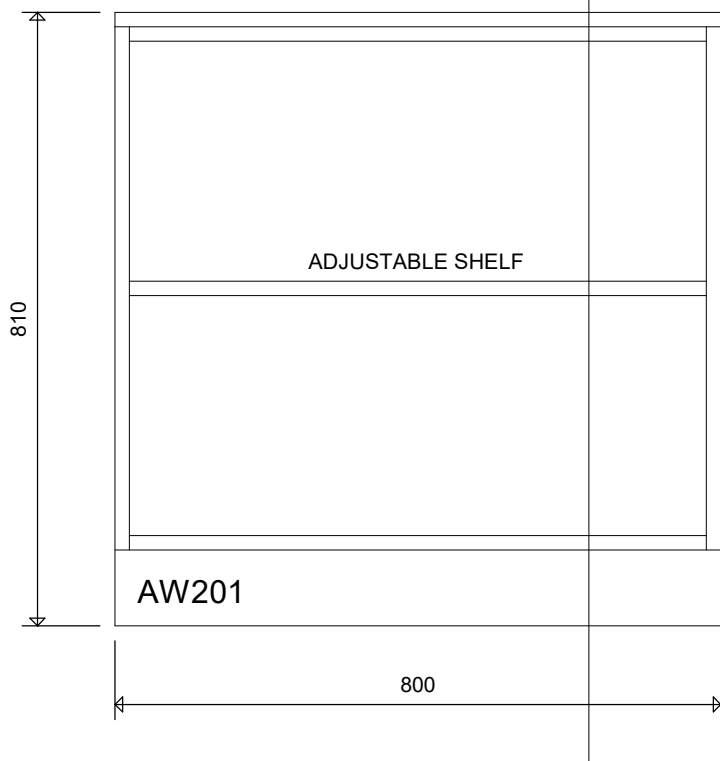

# Waterloo-Oxford District Secondary School

1206 Snyder's Rd W, Baden, ON N3A 1A4

WINDOW REPLACEMENTS, INTERIOR ALTERATIONS  
AND HVAC UPGRADES

Project No.:  
**1167A**

LOW BOOKSHELF - ELEVATION

Plot Date:  
2026-03-26



102-320 Thamees St. London ON Canada N6A 0E1  
P 519 432 6644 F 519 432 6737  
cornerstonearchitecture.ca

**AW201**

© 2025 Cornerstone Architecture Incorporated. All Rights Reserved.

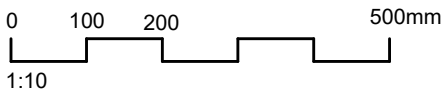
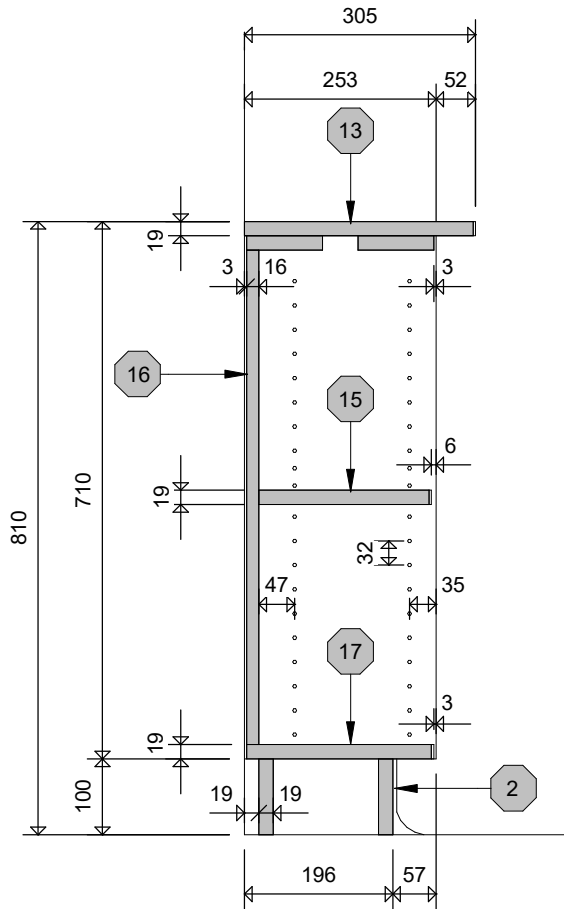

# Waterloo-Oxford District Secondary School

1206 Snyder's Rd W, Baden, ON N3A 1A4)OW REPLACEMENTS, INTERIOR ALTERATIONS AND HVAC UPGRADES

LOW BOOKSHELF - SECTION

Project No.:

1167A

Plot Date:

2026-03-26

**CORNERSTONE**  
ARCHITECTURE

102-320 Thamees St. London ON Canada N6A 0E1  
P 519 432 6644 F 519 432 6737  
cornerstonearchitecture.ca

© 2025 Cornerstone Architecture Incorporated. All Rights Reserved.

**AW202**

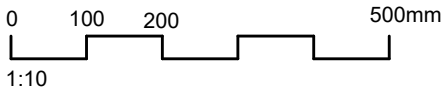
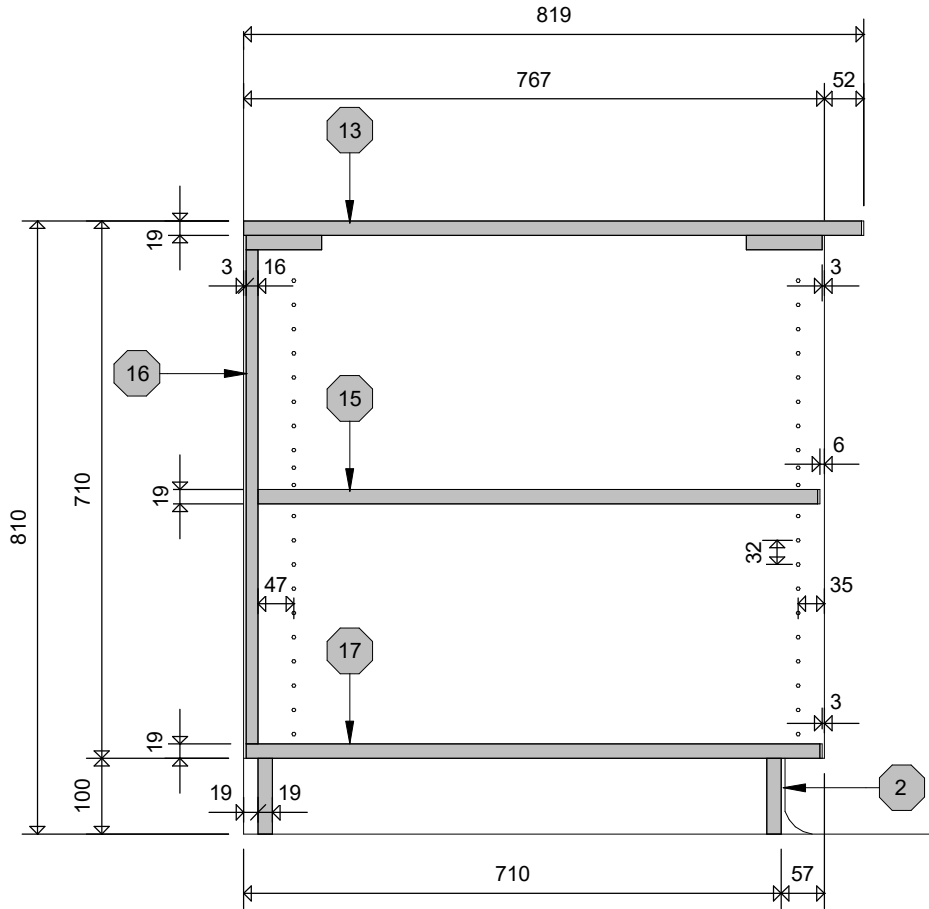

# Waterloo-Oxford District Secondary School

1206 Snyder's Rd W, Baden, ON N3A 1A4)OW REPLACEMENTS, INTERIOR ALTERATIONS AND HVAC UPGRADES

DEEP LOW BOOKSHELF - SECTION

Project No.:

1167A

Plot Date:

2026-03-26

**CORNERSTONE**  
ARCHITECTURE

102-320 Thamees St. London ON Canada N6A 0E1  
P 519 432 6644 F 519 432 6737  
cornerstonearchitecture.ca

© 2025 Cornerstone Architecture Incorporated. All Rights Reserved.

**AW202A**

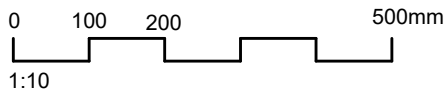
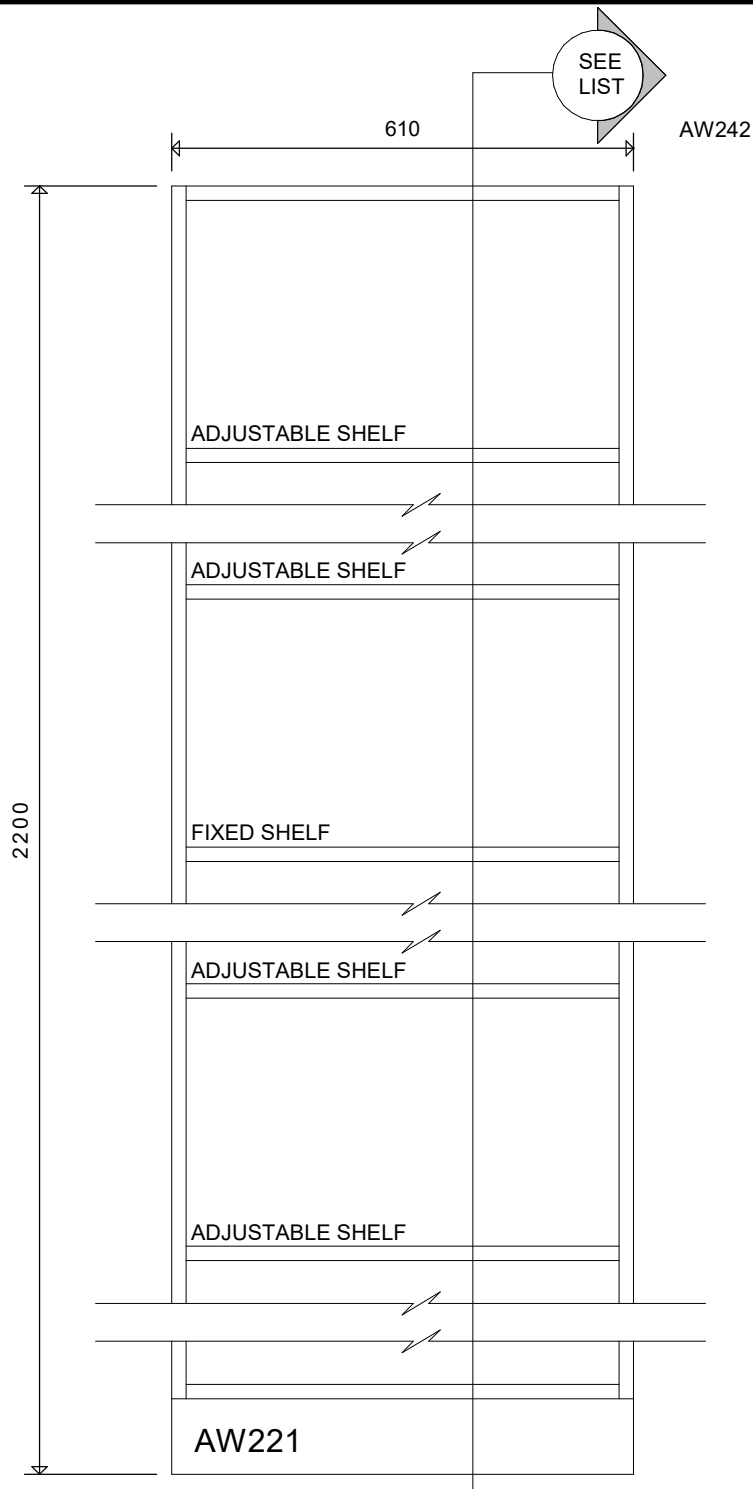

# Waterloo-Oxford District Secondary School

1206 Snyder's Rd W, Baden, ON N3A 1A4)OW REPLACEMENTS, INTERIOR ALTERATIONS AND HVAC UPGRADES

Project No.:

1167A

TALL BOOKSHELF - ELEVATION

Plot Date:

2026-03-26

**CORNERSTONE**  
ARCHITECTURE

102-320 Thamees St. London ON Canada N6A 0E1  
P 519 432 6644 F 519 432 6737  
cornerstonearchitecture.ca

**AW221**

© 2025 Cornerstone Architecture Incorporated. All Rights Reserved.

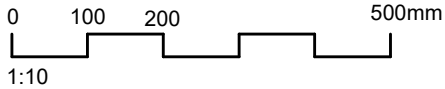
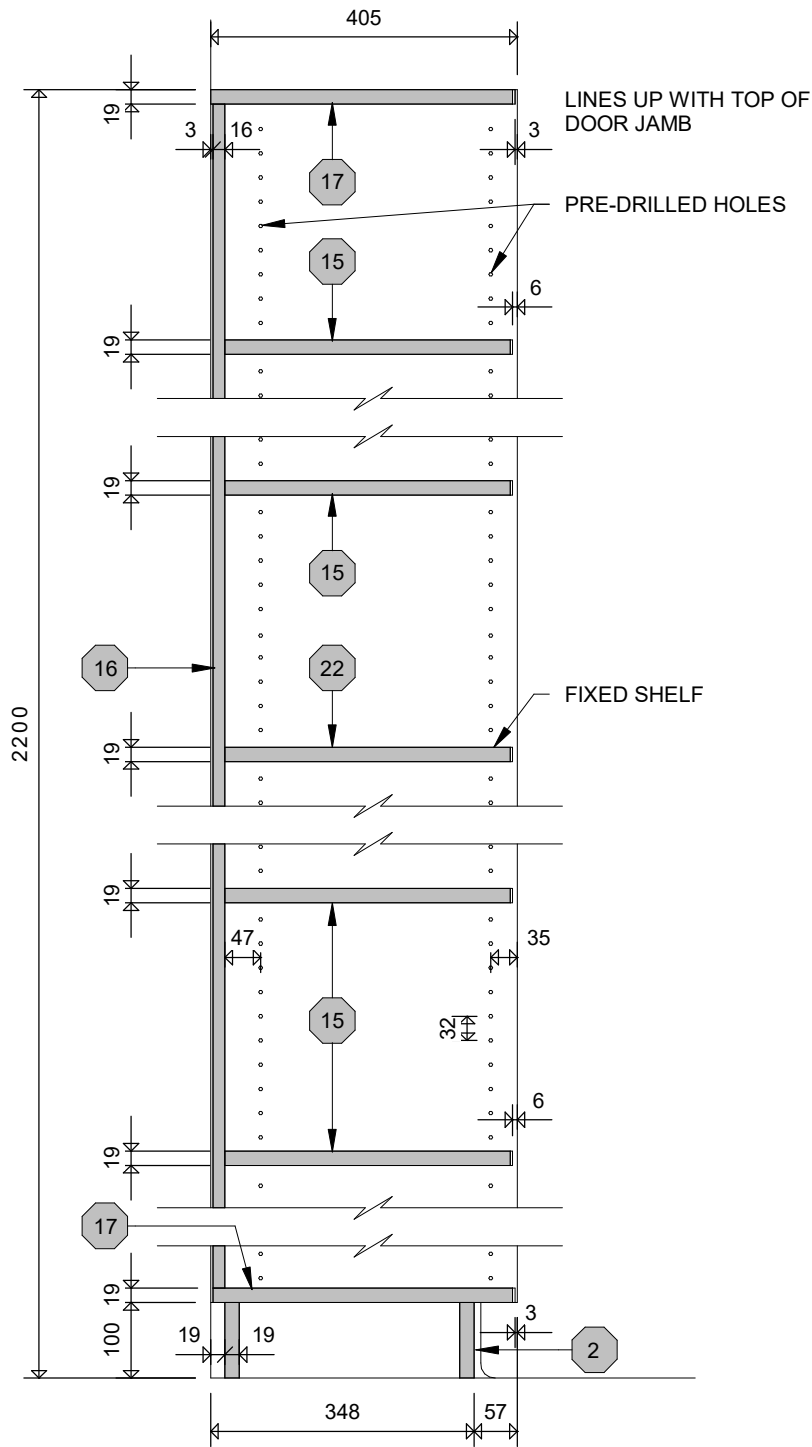

# Waterloo-Oxford District Secondary School

1206 Snyder's Rd W, Baden, ON N3A 1A4

WINDOW REPLACEMENTS, INTERIOR ALTERATIONS  
AND HVAC UPGRADES

Project No.:

1167A

TALL BOOKSHELF - SECTION

Plot Date:

2026-03-26

**CORNERSTONE**  
ARCHITECTURE **E**

102-320 Thamees St. London ON Canada N6A 0E1  
P 519 432 6644 F 519 432 6737  
cornerstonearchitecture.ca

**AW242**

© 2025 Cornerstone Architecture Incorporated. All Rights Reserved.

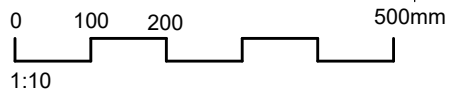
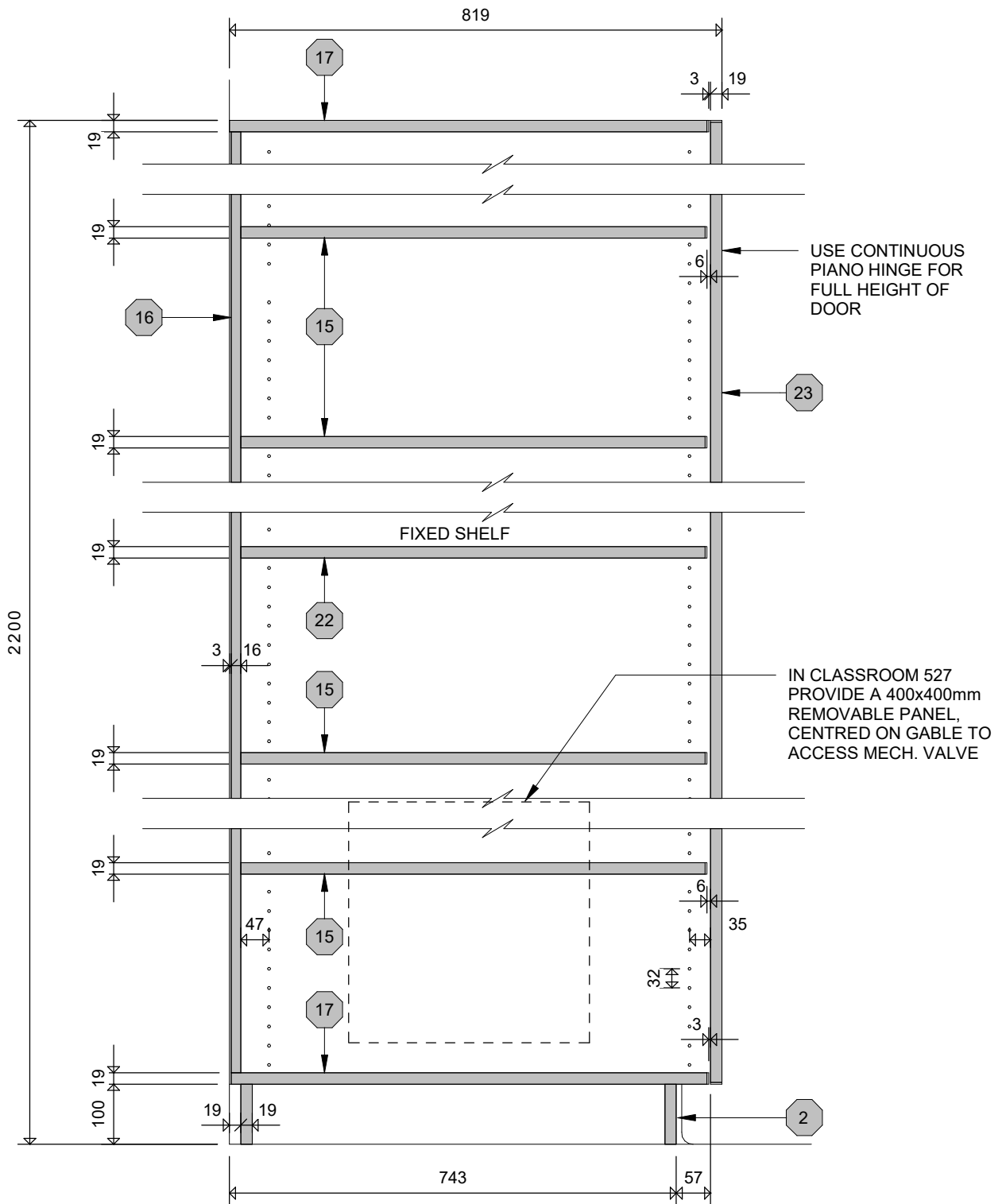

REFER TO SPECIFICATIONS FOR LOCKING REQUIREMENTS

# Waterloo-Oxford District Secondary School

1206 Snyder's Rd W, Baden, ON N3A 1A4)OW REPLACEMENTS, INTERIOR ALTERATIONS AND HVAC UPGRADES

5 SHELF STORAGE CABINET

Project No.:  
**1167A**

Plot Date:  
2026-03-26

**CORNERSTONE**  
ARCHITECTURE

102-320 Thamees St. London ON Canada N6A 0E1  
P 519 432 6644 F 519 432 6737  
cornerstonearchitecture.ca

**AW306**

© 2025 Cornerstone Architecture Incorporated. All Rights Reserved.

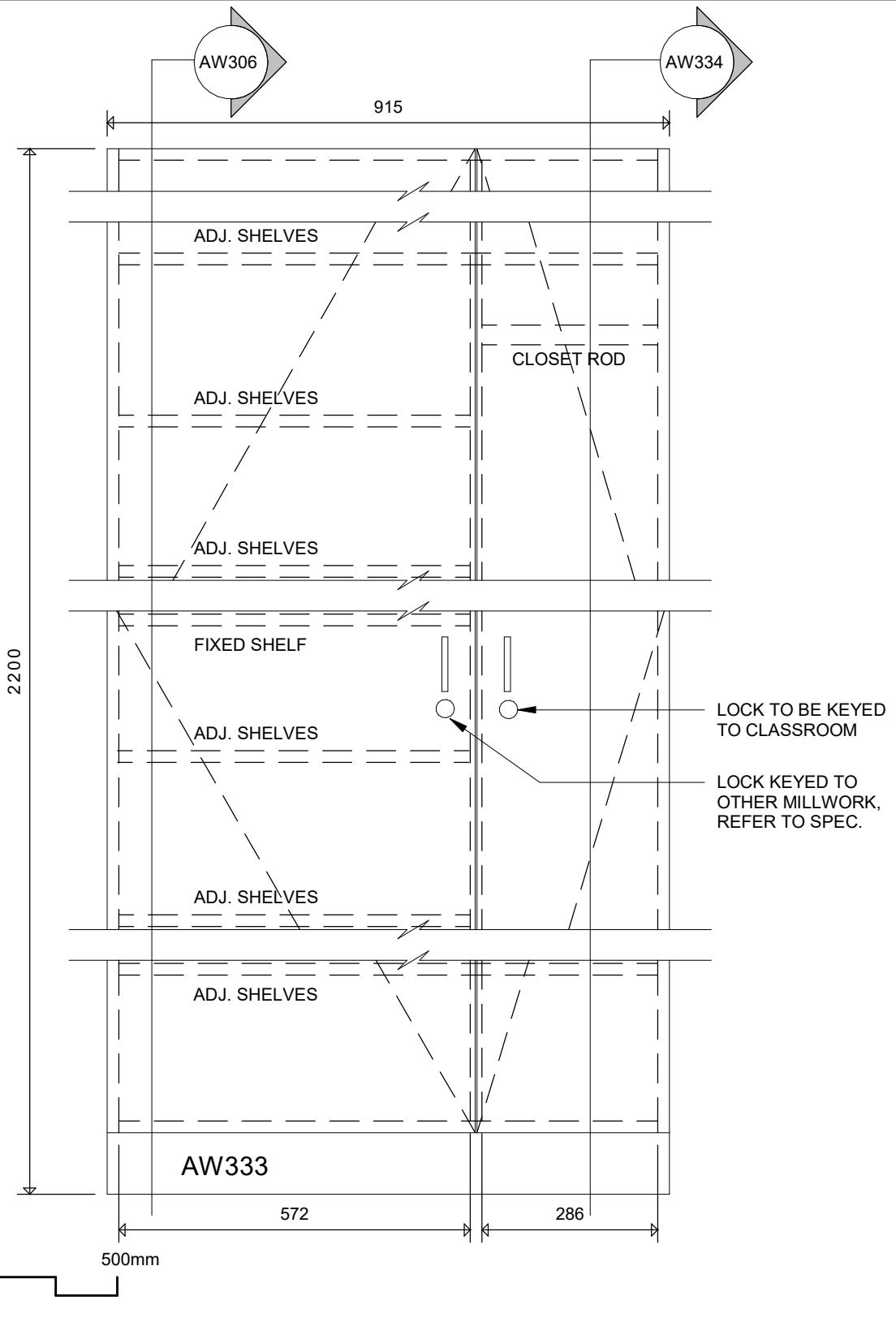

# Waterloo-Oxford District Secondary School

1206 Snyder's Rd W, Baden, ON N3A 1A4

WINDOW REPLACEMENTS, INTERIOR ALTERATIONS  
AND HVAC UPGRADES

Project No.:

1167A

TEACHERS CLOSET - TYPE 4 - ELEVATION

Plot Date:

2026-03-26

**CORNERSTONE**  
ARCHITECTURE **E**

102-320 Thamees St. London ON Canada N6A 0E1  
P 519 432 6644 F 519 432 6737  
cornerstonearchitecture.ca

**AW333**

© 2025 Cornerstone Architecture Incorporated. All Rights Reserved.

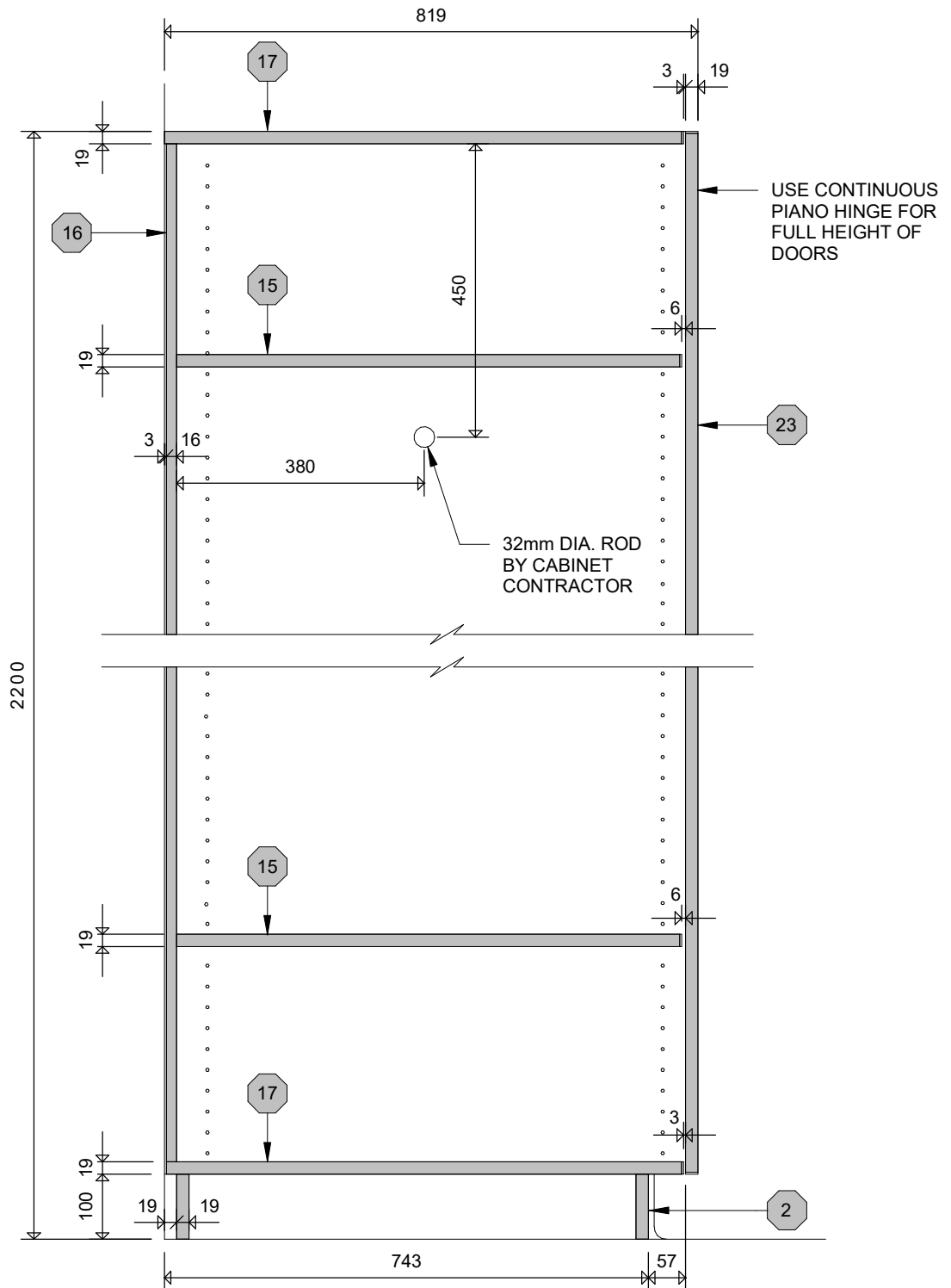

THIS CABINET TO RECIEVE LOCK SET  
TO BE KEYABLE TO CLASSROOM DOOR

# Waterloo-Oxford District Secondary School

1206 Snyder's Rd W, Baden, ON N3A 1A4

WINDOW REPLACEMENTS, INTERIOR ALTERATIONS  
AND HVAC UPGRADES

Project No.:

1167A

TEACHERS CLOSET - TYPE 4 - SECTION

Plot Date:

2026-03-26

**CORNERSTONE**  
ARCHITECTURE **E**

102-320 Thamees St. London ON Canada N6A 0E1  
P 519 432 6644 F 519 432 6737  
cornerstonearchitecture.ca

**AW334**

© 2025 Cornerstone Architecture Incorporated. All Rights Reserved.

NOTE: REFER TO AW001 AND THE SPECIFICATIONS FOR APPROPRIATE PRODUCTS

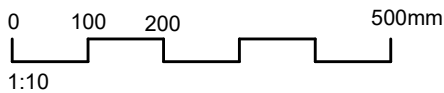
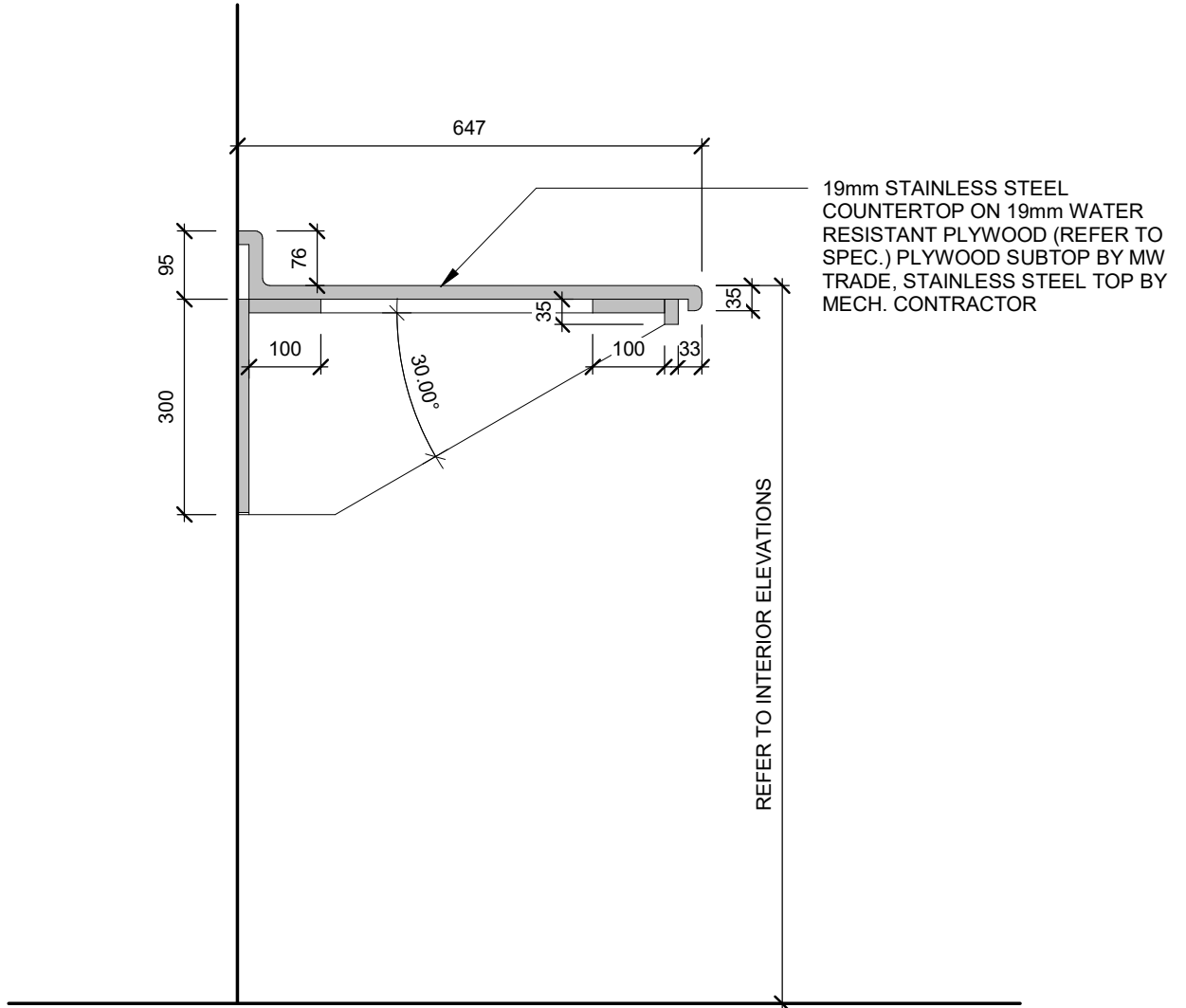

# Waterloo-Oxford District Secondary School

1206 Snyder's Rd W, Baden, ON N3A 1A4

WINDOW REPLACEMENTS, INTERIOR ALTERATIONS  
AND HVAC UPGRADES

Project No.:

1167A

OPEN SHELF - SECTION

Plot Date:

2026-03-26

**CORNERSTONE**  
ARCHITECTURE **E**

102-320 Thamees St. London ON Canada N6A 0E1  
P 519 432 6644 F 519 432 6737  
cornerstonearchitecture.ca

**AW402**

© 2025 Cornerstone Architecture Incorporated. All Rights Reserved.

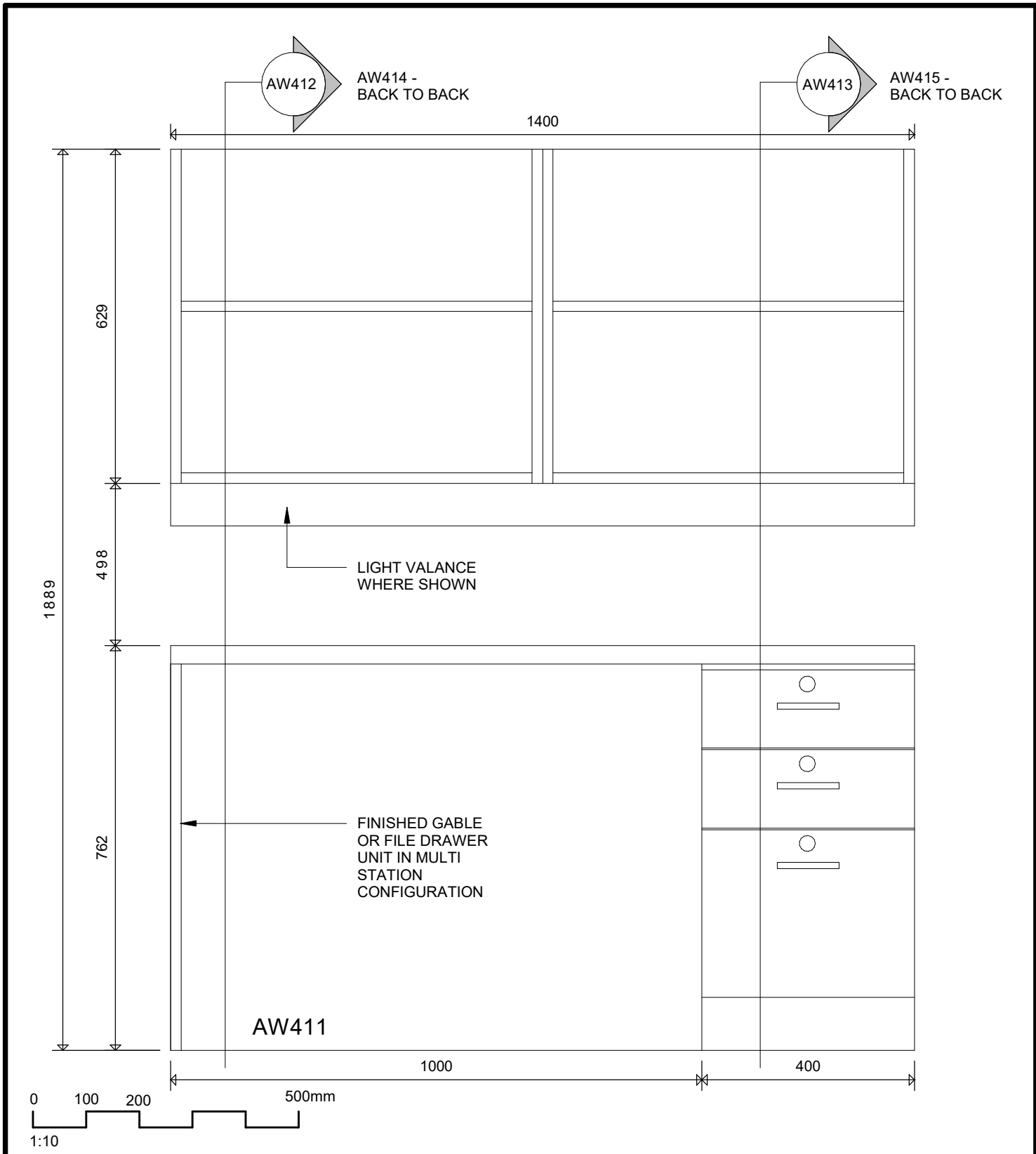

# Waterloo-Oxford District Secondary School

1206 Snyder's Rd W, Baden, ON N3A 1A4

WINDOW REPLACEMENTS, INTERIOR ALTERATIONS  
AND HVAC UPGRADES

Project No.:

1167A

TEACHERS WORKSTATION

Plot Date:

2026-03-26

**CORNERSTONE**  
ARCHITECTURE **E**

102-320 Thamees St. London ON Canada N6A 0E1  
P 519 432 6644 F 519 432 6737  
cornerstonearchitecture.ca

**AW411**

© 2025 Cornerstone Architecture Incorporated. All Rights Reserved.

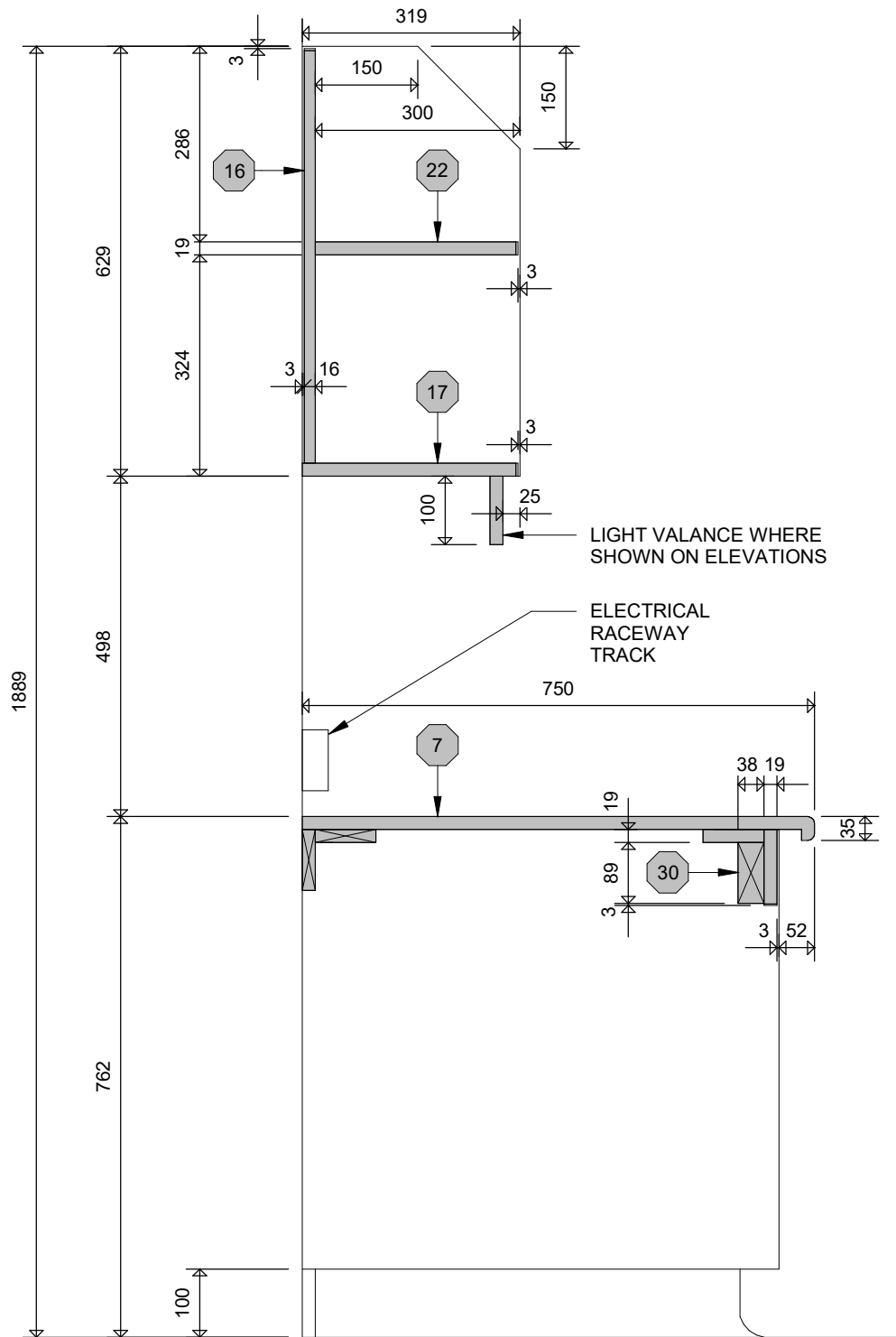

LIGHT VALANCE WHERE SHOWN ON ELEVATIONS

ELECTRICAL RACEWAY TRACK

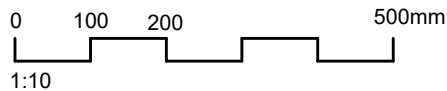

# Waterloo-Oxford District Secondary School

1206 Snyder's Rd W, Baden, ON N3A 1A4)OW REPLACEMENTS, INTERIOR ALTERATIONS AND HVAC UPGRADES

TEACHER WORKSTATION - SECTION 1

Project No.:

1167A

Plot Date:

2026-03-26

**CORNERSTONE**  
ARCHITECTURE

102-320 Thamees St. London ON Canada N6A 0E1  
P 519 432 6644 F 519 432 6737  
cornerstonearchitecture.ca

AW412

© 2025 Cornerstone Architecture Incorporated. All Rights Reserved.

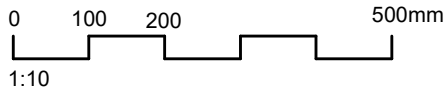
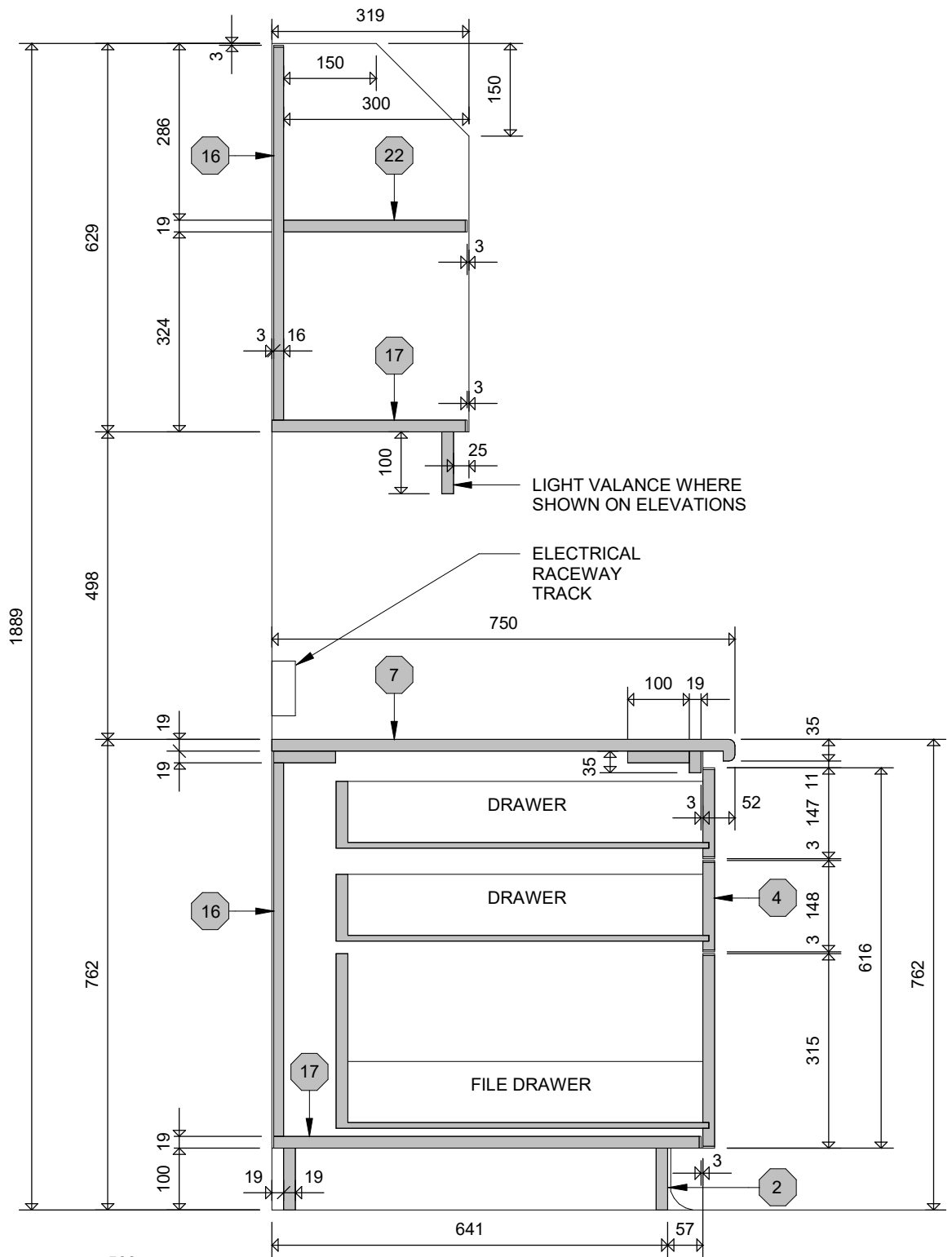

# Waterloo-Oxford District Secondary School

1206 Snyder's Rd W, Baden, ON N3A 1A4

WINDOW REPLACEMENTS, INTERIOR ALTERATIONS  
AND HVAC UPGRADES

Project No.:

1167A

TEACHERS WORK STATION - SECTION 2

Plot Date:

2026-03-26

**CORNERSTONE**  
ARCHITECTURE **E**

102-320 Thamees St. London ON Canada N6A 0E1  
P 519 432 6644 F 519 432 6737  
cornerstonearchitecture.ca

**AW413**

© 2025 Cornerstone Architecture Incorporated. All Rights Reserved.

## **PART 1 - GENERAL**

### 1.1 General

- .1 Conform to Division 01 – General Requirements.

### 1.2 Related Sections

- .1 Section 07 26 00 – Vapour Retarders.
- .2 Section 07 27 10 – Air Barriers.

### 1.3 References

- .1 American Society for Testing and Materials (ASTM)
  - .1 ASTM E96/ E96M -16, Test Methods for Water Vapor Transmission of Materials.
  - .2 ASTM C726-17, Standard Specification for Mineral Fiber Roof Insulation Board.
- .2 Canadian Gas Association (CGA)
  - .1 CAN/CGA-B149.1-15, Natural Gas Installation Code.
  - .2 CAN/CGA-B149.2-15, Propane Installation Code.
- .3 Canadian General Standards Board (CGSB)
  - .1 CAN/CGSB 51.11-92, Rigid Insulation.
- .4 Underwriters Laboratories of Canada (ULC)
  - .1 CAN/ULC-S701-11, Thermal Insulation, Polystyrene, Boards and Pipe Coverings.
  - .2 CAN/ULC-S702-14, Thermal Insulation, Mineral Fibre, for Buildings.

## **PART 2 - PRODUCTS**

### 2.1 Insulation

- .1 Rigid cellular polystyrene; cavity wall insulation: to CAN/ULC-S701-05, type 3:
  - .1 Acceptable material
    - .1 Styrofoam Brand CavityMate Plus XPS Ultra by Dupont.
    - .2 Foamular NGX C-200 by Owens Corning Canada Inc.

### 2.2 Adhesive

- .1 Adhesive: as recommended by manufacturer for fully adhered application.

## **PART 3 - EXECUTION**

### 3.1 General

- .1 Install materials in accordance with manufacturer's installation instructions.

### 3.2 Examination

- .1 Examine substrates and immediately inform Consultant in writing of defects.
- .2 Take measurements of the Place of Work to ensure that work is fabricated to fit structure, surrounding construction, around obstructions and projections in place, or as indicated; and to suit locations of services.

- .3 Verify that backup construction is aligned for proper installation of Work before commencing erection.

### 3.3 Installation - General

- .1 Surfaces to receive insulation shall be dry and free of dew, frost, voids, loose material, oil, grease, asphalt curing compounds and other matter detrimental to bond of adhesive. Adhesive shall be compatible with all substrate materials.
- .2 Apply adhesives and install insulation in accordance with manufacturer's printed recommendations. Apply at rate as required to prevent displacement of insulation boards during construction operations.
- .3 Butt joints tightly and offset vertical and horizontal joints in multi-layer applications to form an unbroken thermal envelope. Use only insulation boards free from chipped or broken edges. Use largest possible dimensions to reduce number of joints.
- .4 Apply insulation to ensure total and complete coverage of surfaces indicated to be insulated, and in direct contact with such surfaces. Unless otherwise specified, apply insulation in single layer of thickness indicated.
- .5 Ensure integrity and continuity of insulation at juncture with different types of materials and seal in an acceptable manner.
- .6 Do not enclose insulation until it has been reviewed and accepted by Consultant.

### 3.4 Above Grade Insulation

- .1 Secure rigid insulation boards to substrate at rate of 6 each per 610mm x 1220mm board minimum, with corrosion resistant mechanical fasteners complete with 25mm plastic washers.
- .2 Apply rigid insulation at through-wall flashings as indicated on Drawings and as follows:
  - .1 Over through-wall flashings at grade, prior to application of sprayed foam insulation.
  - .2 Under elevated through-wall flashings, full thickness of cavity.
  - .3 Over elevated through-wall flashings, prior to application of sprayed foam insulation.

END OF SECTION

## **PART 1 - GENERAL**

### 1.1 General

- .1 Conform to Division 01 – General Requirements.

### 1.2 References

- .1 Canadian General Standards Board (CGSB)
  - .1 CAN/CGSB-51.34-M86, Vapour Barrier, Polyethylene Sheet, for Use in Building Construction.
- .2 Canadian Standards Association (CSA)
  - .1 CAN/CSA-ISO 9001, Requirements for Quality Assurance, Parts 1, 2 and 3.

### 1.3 Submittals

- .1 Submit proof of manufacturer's CCMC Listing and listing number to Consultant.
- .2 Manufacturer's Instructions: Provide to indicate special handling criteria, installation sequence, and cleaning procedures.

### 1.4 Product Data

- .1 Submit product data in accordance with Section 01 33 00 - Submittal Procedures.
- .2 Submit WHMIS MSDS - Material Safety Data Sheets in accordance with Section 01 33 00 Submittal Procedures.
- 
- .3 Submit product data sheets for sheet vapour retarders. Include:
  - .1 Product characteristics.
  - .2 Performance criteria.
  - .3 Limitations.

### 1.5 Mock-Ups

- .1 Submit mock-ups in accordance with Section 01 33 00 – Submittal Procedures.
- .2 Construct mock-up of sheet vapour barrier installation including one lap joint, one inside corner and at one electrical box. Mock-up may be part of finished work.
- .3 Allow 24 hours for inspection of mock-up by Consultant before proceeding with vapour barrier work.

## **PART 2 - PRODUCTS**

### 2.1 Sheet Vapour Barrier

- .1 Polyethylene film: to CAN/CGSB-51.34, 0.15mm thick, except under slabs on grade, as Specified under Section 03 30 00.

### 2.2 Accessories

- .1 Joint sealing tape: air resistant pressure sensitive adhesive tape, type recommended by vapour barrier manufacturer, 50mm wide for lap joints and perimeter seals, 25mm wide elsewhere.

- .2 Sealant: To Section 07 92 10 - Joint Sealing.
- .3 Staples: minimum 6mm leg.
- .4 Moulded box vapour barrier: factory-moulded polyethylene box for use with recessed electric switch and outlet device boxes.

### **PART 3 - EXECUTION**

#### 3.1 Installation

- .1 Ensure services are installed and inspected prior to installation of retarder.
- .2 Install sheet vapour retarder on warm side of exterior wall and ceiling assemblies prior to installation of gypsum board to form continuous retarder.
- .3 Use sheets of largest practical size to minimize joints.
- .4 Inspect for continuity. Repair punctures and tears with sealing tape before work is concealed.

#### 3.2 Exterior Surface Openings

- .1 Cut sheet vapour retarder to form openings and ensure material is lapped and sealed to frame.

#### 3.3 Perimeter Seals

- .1 Seal perimeter of sheet vapour barrier as follows:
  - .1 Apply continuous bead of sealant to substrate at perimeter of sheets.
  - .2 Lap sheet over sealant and press into sealant bead.
  - .3 Install staples through lapped sheets at sealant bead into wood substrate.
  - .4 Ensure that no gaps exist in sealant bead. Smooth out folds and ripples occurring in sheet over sealant.

#### 3.4 Lap Joint Seals

- .1 Seal lap joints of sheet vapour barrier as follows:
  - .1 Attach first sheet to substrate.
  - .2 Apply continuous bead of sealant over solid backing at joint.
  - .3 Lap adjoining sheet minimum 150mm and press into sealant bead.
  - .4 Install staples through lapped sheets at sealant bead into wood substrate.
  - .5 Ensure that no gaps exist in sealant bead. Smooth out folds and ripples occurring in sheet over sealant.

#### 3.5 Electrical Boxes

- .1 Seal electrical switch and outlet device boxes that penetrate vapour barrier as follows:
  - .1 Install moulded box vapour barrier.
  - .2 Apply sealant to seal edges of flange to main vapour barrier and seal wiring penetrations through box cover.

END OF SECTION

## **PART 1 - GENERAL**

### 1.1 General

- .1 Conform to Division 01 – General Requirements.

### 1.2 Section Includes

- .1 Materials and installation methods providing primary air/ vapour barrier materials and assemblies.
- .2 Air/ vapour barrier materials to provide continuous seal between components of building envelope and building penetrations.

### 1.3 Related Sections

- .1 Section 04 22 00 – Concrete Unit Masonry.
- .2 Section 07 21 13 – Board Insulation.
- .3 Section 07 26 00 – Vapour Retarders
- .4 Section 07 92 10 – Joint Sealing.
- .5 Section 09 21 16 – Gypsum Board Assemblies.

### 1.4 References

- .1 Canadian Construction Documents Committee
  - .1 CCDC 2 - Stipulated Price Contract.
- .2 Canadian General Standards Board (CGSB)
  - .1 CAN/CGSB-19.13M-M87, Sealing Compound, One Component, Elastomeric Chemical Curing.
  - .2 CAN/CGSB-19.18M-M87, Sealing Compound, One Component, Silicone Base Solvent Curing.
  - .3 CAN/CGSB-19.24M-M90, Multi-Component, Chemical Curing Sealing Compound.
  - .4 CGSB 19-GP-14M-12, Sealing Compound, One Component, Butyl-Polyisobutylene Polymer Base, Solvent Curing.
- .3 NBCC 2015; Part 5 - Environmental Separation
- .4 Sealant and Waterproofer's Institute - Sealant and Caulking Guide Specification.

### 1.5 Submittals

- .1 Submit shop drawings in accordance with Section 01 33 00 - Submittal Procedures.
  - .1 Provide drawings of special joint conditions.
- .2 Submit manufacturer's product data sheets in accordance with Section 01 33 00 - Submittal Procedures.
- .3 Submit manufacturer's installation instructions in accordance with Section 01 33 00 - Submittal Procedures.

### 1.6 Quality Assurance

- .1 Perform Work in accordance with Sealant and Waterproofer's Institute - Sealant and Caulking Guide Specification requirements for materials and installation.
- .2 Perform Work in accordance with National Air Barrier Association - Professional Contractor Quality Assurance Program and requirements for materials and installation.
- .3 Maintain one copy of documents on site.

1.7 Qualifications

- .1 Applicator: Company specializing in performing work of this Section with experience in the installation of air/vapour barrier systems. Completed installation must be approved by the material manufacturer.

1.8 Mock-Up

- .1 Construct typical exterior wall panel, 5m long by 5m wide, incorporating window, frame and sill, insulation, building corner condition, junction with roof system; illustrating materials interface and seals.
- .2 Locate where directed.
- .3 Mock-up may remain as part of the Work.
- .4 Allow 24 hours for inspection of mock-up by Consultant before proceeding with air/vapour barrier Work.

1.9 Delivery, Storage and Handling

- .1 Deliver, store and handle materials in accordance with Section 01 61 00 - Basic Product Requirements.
- .2 Deliver, store and handle materials in accordance with manufacturer's written instructions.
- .3 Clean spills and leave area as it was prior to spill.

1.10 Project Environmental Requirements

- .1 Maintain temperature and humidity recommended by materials manufactures before, during and after installation.

1.11 Sequencing

- .1 Sequence work to permit installation of materials in conjunction with related materials and seals.
- .2 Schedule installation of air barriers to coincide with the application of insulation as closely as possible. Avoid leaving air barriers exposed for long periods of time.

1.12 Warranty

- .1 Provide a three year warranty under provisions of Section 01 78 00 - Closeout Submittals.
- .2 Warranty: Include coverage of installed sealant and sheet materials which fail to achieve air tight and watertight seal, exhibit loss of adhesion or cohesion, or do not cure.

**PART 2 - PRODUCTS**

2.1 Membrane Air Barrier

- .1 Sheet membrane: 40 mil self-adhering membrane air barrier consisting of SBS rubberized asphalt compound cross laminated to a polyethylene film.
  - .1 When air and/or surface temperature is above 0°C; "Blueskin SA" by Bakor, "Sealtight Air-Shield" by W.R. Meadows of Canada, "PERM-A-BARRIER" by Grace Construction Products and "Soprseal Stick 1100" by Soprema are acceptable products.

- .2 When air and/or surface temperature drops below 0°C use low temperature products, "Blueskin SA LT" by Bakor, "PERM-A-BARRIER Low Temperature Membrane" by Grace Construction Products or "Sopraseal Stick 1100 Winter Grade" by Soprema.
  - .3 Install in widths to suit wall condition and to minimize joints.
  - .2 Lap adhesive; single component rubberized mastic as recommended by manufacturer.
  - .3 Primer; as recommended by manufacturer.
- 2.2 Sealants
- .1 Sealants in accordance with Section 07 92 10 - Joint Sealing.
- 2.3 Accessories
- .1 Thinner and cleaner for Sheet Seal: As recommended by sheet material manufacturer.

### **PART 3 - EXECUTION**

- 3.1 Examination
- .1 Verify that surfaces and conditions are ready to accept the Work of this Section.
  - .2 Ensure all surfaces are clean, dry, sound, smooth, continuous and comply with air barrier manufacturer's requirements.
  - .3 Report any unsatisfactory conditions to the Consultant in writing.
  - .4 Do not start work until deficiencies have been corrected. Commencement of Work implies acceptance of conditions.
- 3.2 Preparation
- .1 Remove loose or foreign matter which might impair adhesion of materials.
  - .2 Ensure all substrates are clean of oil or excess dust; all masonry joints struck flush, and open joints filled; and all concrete surfaces free of large voids, spalled areas or sharp protrusions.
  - .3 Ensure all substrates are free of surface moisture prior to application of self-adhesive membrane and primer.
  - .4 Ensure metal closures are free of sharp edges and burrs.
  - .5 Fill voids in masonry substrate smaller than 6mm with a trowel application of liquid air barrier. Voids larger than 6mm to be covered by sheet seal.
  - .6 Prime substrate surfaces to receive sheet seal in accordance with manufacturer's instructions.
- 3.3 Membrane Air Barrier Installation
- .1 Install materials in accordance with manufacturer's instructions. Ensure flashing materials are consistent with manufacturer's recommendations for temperature range expected during installation.
  - .2 Do not install sheet membrane air barrier materials when air and/or surface temperatures drop below -10°C.
  - .3 Install sheet membrane air barriers only in dry, fair weather when there is no threat of precipitation.
  - .4 Prime all surfaces to receive membrane air barriers just prior to application of membrane in strict accordance with manufacturers instructions. Reprime surfaces if contaminated with dust.

- .5 Secure sheet seal to masonry and concrete materials. Ensure that all primed surface receive membrane in same day. Lap joints 50mm minimum and seal with mastic. Position lap seal over firm bearing.
- .6 Press membrane firmly into place by means of a hand roller with sufficient pressure to ensure continuous and intimate contact with substrate. Take care to avoid blisters, wrinkles, or folds in membrane.
- .7 Apply sheet seal over exterior surfaces/voids, lapping masonry by a minimum of 100mm.
- .8 Apply sheet seals over wall infill areas.
- .9 Install sheet seal around all window, door openings, canopies/ overhangs and mechanical and electrical openings and other protrusions or wall penetrations in masonry walls.
- .10 Install sheet seal at all parapet details to bridge roofing air barrier and exterior wall air barrier.
- .11 Install sheet seal to bridge over all exposed steel in exterior masonry walls.

3.4 Protection of Work

- .1 Protect finished Work in accordance with Section 01 61 00 - Basic Product Requirements.
- .2 Do not permit adjacent work to damage work of this Section.
- .3 Ensure finished Work is protected from climatic conditions.

END OF SECTION

---

## **PART 1 - GENERAL**

### 1.1 General

- .1 Conform to Division 01 – General Requirements.

### 1.2 Related Sections

- .1 Section 07 27 10 – Air Barriers.
- .2 Section 07 62 00 – Sheet Metal Flashing and Trim.
- .3 Section 07 92 10 – Joint Sealing.

### 1.3 References

- .1 American Society for Testing and Materials (ASTM)
  - .1 ASTM A446/ A446 - 93, Specification for Steel Sheet, Zinc-Coated (Galvanized) by the Hot-Dip Process, General Requirements.
  - .2 ASTM A525 - 93, Specification for Steel Sheet Zinc Coated (Galvanized) by the Hot Dipped Process, General Requirements.
  - .3 ASTM A780/ A780M – 09 (2015), Standard Practice for Repair of Damaged Hot-Dip Coatings.
- .2 Canadian General Standards Board (CGSB)
  - .1 CGSB Specification 19-GP-5M, Sealing Compound, One Component, Acrylic Base, Solvent Curing.
  - .2 CAN/CGSB-19.24-M90, Sealing Compound, Multi-Component, Chemical Curing.
- .3 Canadian Standards Association (CSA)
  - .1 CSA Standard G 164-M92 (R2003), Hot Dip Galvanizing of Irregularly Shaped Articles.
  - .2 CAN/CSA-S136-16, Cold Formed Steel Structural Members.
- .4 Meet specified requirements of CAN/CSA-S136-M89, Cold Formed Steel Structural Members and requirements of applicable jurisdictional authorities for each preformed metal system.
- .5 Requirements specified in this Section are intended to modify, supplement, or clarify specifications contained in CAN/CSA-S136-16.
- .6 Recommendations contained in Standard Specifications and Technical Bulletins of the Canadian Sheet Steel Building Institute for materials and performance of system will establish minimum standards for work not specified in CAN/CSA-S136-16, by jurisdictional authorities, or in this Section.

### 1.4 Quality Assurance

- .1 Mock-Up
  - .1 Construct a 1200mm x 1200mm mock-up of total preformed metal siding system.
  - .2 Include all components and examples of all mitred corners.
  - .3 Allow 24 hours for inspection of mock-up by Consultant before proceeding with preformed metal siding work.

### 1.5 Samples

- .1 Submit samples in accordance with Section 01 33 00 - Submittal Procedures.
- .2 Submit duplicate 300mm 300mm samples of siding material, of colour and profile specified.

### 1.6 Shop Drawings

- .1 Submit shop drawings in accordance with Section 01 33 00 - Submittal Procedures.

- .2 Indicate dimensions, profiles, attachment methods, schedule of wall elevations, trim and closure pieces, and related work.
- 1.7 Delivery, Storage and Handling
- .1 Package materials to protect finished surfaces of siding from staining and marring.
  - .2 Store materials flat at site under protection to prevent staining from the ground or from collection of water on material, or both; and secured against wind damage.
  - .3 Store insulation and adhesives in dry areas, heated as required to prevent damage to adhesives.
- 1.8 Warranty
- .1 Extended Warranty
    - .1 Warranty contained in GC 12.3 is, with respect to Section 07 46 13, extended from two (2) years to five (5) years. Without restricting generality of warranty, defects shall include leaking, failure to stay in place under expansion, lifting, deformation, deterioration, etc.
    - .2 Contractor hereby warrants that system is suitable for use in this type of installation.

## **PART 2 - PRODUCTS**

### 2.1 Siding System

- .1 Siding system shall be one system, applied to vertical surfaces.
- .2 System shall consist of exterior preformed metal skin on galvanized framing and shall include all flashings, trims and closures.

### 2.2 Materials

- .1 Metals
  - .1 Steel: to meet specified requirements of ASTM A446, Grade A.
  - .2 Galvanizing
    - .1 Zinc Coated Sheet: To meet specified requirements of ASTM Specification A525, zinc coating designation Z275.
    - .2 Accessories and Hardware: Zinc coating to meet specified requirements of CSA G 164, including Appendix A.
- .2 Finishes
  - .1 Precoated Metal: Two coats of acrylic enamel, each baked, applied by a continuous sheet steel coating plant.
    - .1 WeatherX™ coating system, as provided with VicWest products.
    - .2 Pre-coat 8000 Series.
  - .2 Exterior Sheet: 0.025mm thick on exposed face, 0.00075mm thick on unexposed face.
  - .3 Colour: To be selected by Consultant from manufacturer's full stock colour range.
- .3 Preformed Metal Siding
  - .1 Precoated and preformed metal wall cladding panels with base metal thickness of 0.76mm;
    - .1 AD-300 profile.
- .4 Miscellaneous Framing, Flashings and Exposed Trim
  - .1 Girts and Subgirts: Minimum 0.12mm thick zinc coated in depths and configurations noted on the Drawings; clip and girt system, separated by cork gasket as required and shall be designed to accommodate expansion and contraction, dynamic movements and design load requirements.

- 
- .1 Approved product: Enviroclip, as manufactured by Ontario Panelization, or approved alternate.
  - .2 Closures: Minimum 0.76mm thick galvanized sheet steel where not exposed to view.
  - .3 Flashings and Exposed Trim: Minimum 0.46 thick precoated sheet steel in colour to match siding, where exposed to view.
  - .5 Membrane Flashings
    - .1 Sheet Membrane: 40 mil self-adhering membrane flashing consisting of SBS rubberized asphalt compound cross laminated to a polyethylene film.
      - .1 When air and/or surface temperature is above 0°C; "Blueskin SA" by Bakor, "Sealtight Air-Shield" by W.R. Meadows of Canada, "PERM-A-BARRIER" by Grace Construction Products and Sopraseal Stick 1100 by Soprema are acceptable products.
      - .2 When air and/or surface temperature drops below 0°C use low temperature products, "Blueskin SA LT" by Bakor, "PERM-A-BARRIER Low Temperature Membrane" by Grace Construction Products or "Sopraseal Stick 1100 Winter Grade" by Soprema.
      - .3 Install in width to suit wall thickness.
    - .2 Lap adhesive: single component rubberized mastic as recommended by manufacturer.
    - .3 Primer: as recommended by manufacturer.
  - .6 Sealant
    - .1 Acrylic Solvent Release, One Part Sealant: To meet specified requirements of CGSB Specification 19-GP-5.
    - .2 Two Part Polysulphide Sealant: To meet specified requirements of CAN/CGSB-19.24-M90.
    - .3 Polybutene Compound: To meet fabricator's recommendations.
- 2.3 Accessories
- .1 Exposed trim: inside corners, outside corners, cap strip, drip cap, undersill trim, starter strip and window/door trim of same material, as cladding, with fastener holes pre-punched.
- 2.4 Fasteners
- .1 Self-drilling, Type 304 stainless steel.
  - .2 Head finish:
    - .1 Type 304 stainless steel
    - .2 Pre-painted metal, in colour to match prefinished metal panels in exposed locations.
    - .3 Dissimilar materials to be separated/ isolated.
- 2.5 Fabrication
- .1 Roll form profiled panels and other shapes unless impossible because of special design. Use other forming methods only with approval.
  - .2 Form metal panels with bends sharp and true.
  - .3 Fabricate to conform to shop drawings and to allow for structural movements within the systems.
  - .4 Fabricate systems for use with concealed fasteners wherever possible. Where exposed fasteners are required use fasteners with coloured screw heads to match siding colour.
  - .5 Fabricate miscellaneous framing members of specified materials as required to support metal siding.
  - .6 Fabricate systems to prevent entry of water into building and from collection within system assembly and to prevent infiltration of air through system.

- .7 Join intersecting parts together to provide tight, accurately fitted joints with adjoining surfaces in true planes.
- .8 Fabricate system to conform to requirements of reference standards specified.
- .9 Cooperate with applicable Sections to ensure required coordination for installations specified in this Section in conjunction with masonry, structural steel framing, metal deck, sprayed foam insulation, air barriers, membrane roofing, sheet metal work, drywall and steel studs and similar installations by other Sections.

### **PART 3 - EXECUTION**

#### 3.1 Examination

- .1 Take site measurements to ensure that fabrications are provided to fit structure; surrounding construction; around obstructions and projections in place or as shown on Drawings and to suit locations of services.
- .2 Verify backup and support construction is aligned for proper installation of preformed metal system before commencing erection of metal siding.
- .3 Before proceeding with application, ensure that:
  - .1 Metal support is constructed smoothly, in true planes and to match whatever is the design intent.
  - .2 Edges of metal are supported to prevent deflection.
  - .3 Adjacent construction and installation of other work to be incorporated is complete.
  - .4 Work which penetrates system has been installed.

#### 3.2 Erection of Preformed Metal

- .1 Erect systems complete with flashings forming part of system, sub-girts, clips, fasteners, closures and caulking to meet same design criteria as specified for fabrication.
- .2 Cut and flash system penetrations.
- .3 Erect panels in straight lines that are true, level and plumb.
- .4 Provide for differential thermal and structural movement between systems and structure as well as between elements of system.
- .5 Attach systems to supporting structure and to other siding components with fasteners of the same material and colour as the exterior panels except where other materials are approved.
- .6 Install cap flashings, drip flashings, internal flashings, copings, closures and corners, of same material and finish as cladding, brake formed to shape. Close all flute ends.
- .7 Seal joints within system watertight.
- .8 Caulk between preformed metal specified in this Section and installations of other Sections to meet requirements of Section 07 92 10 and to provide a watertight installation.
- .9 Fasteners: concealed fasteners.
- .10 Apply a continuous bead of sealant to the face of the supports at the top and bottom of the girts and perimeter of openings.
- .11 Erect systems by its fabricator or approved agent.

#### 3.3 Metal Cladding Installation Tolerances

- .1 Maintain the following installation tolerances:
  - .1 Maximum variation from plane or location shown on reviewed shop drawings: 20mm/ 10m of length and up to 30mm/ 10m maximum.
  - .2 Maximum offset from true alignment between two adjacent members abutting end to end, in line: 1mm.

3.4 Adjustment and Cleaning

- .1 After erection, touch up galvanized coatings removed or damaged during erection.
- .2 Remove damaged, dented, defaced, defectively finished or tool marked components and replace with new.
- .3 Refinish shop applied finishes in field only with written approval from Consultant.
- .4 Clean of dirt resulting from erection from surfaces exposed to view.

END OF SECTION

---

**PART 1 - GENERAL**

## 1.1 General

- .1 Conform to Division 01 – General Requirements.

## 1.2 Related Sections

- .1 Section 06 10 10 – Rough Carpentry.
- .2 Section 07 46 13 – Preformed Metal Siding.
- .3 Section 07 92 10 – Joint Sealing.

## 1.3 References

- .1 Aluminum Association
  - .1 Aluminum Sheet Metal Work in Building Construction.
  - .2 Designation System for Aluminum Finishes.
- .2 American Society for Testing and Materials (ASTM)
  - .1 ASTM A 167 - 99(2004), Specification for Stainless and Heat-Resisting Chromium-Nickel Steel Plate, Sheet, and Strip.
  - .2 ASTM A591/ A591M - 98, Specification for Steel Sheet, Electrolytic Zinc-Coated, for Light Coating Mass Applications.
  - .3 ASTM A 606-04, Specification for Steel, Sheet and Strip, High-Strength, Low-Alloy, Hot-Rolled and Cold-Rolled, with Improved Atmospheric Corrosion Resistance.
  - .4 ASTM A653/ A653 M - 17, Specification for Steel Sheet, Zinc-Coated (Galvanized) or Zinc-Iron Alloy-Coated (Galvannealed) by the Hot-Dip Process.
  - .5 ASTM A 792/A 792M – 10(2015), Specification for Steel Sheet, 55% Aluminum-Zinc Alloy-Coated by the Hot-Dip Process.
  - .6 ASTM B32 - 08(2014), Specification for Solder Metal.
  - .7 ASTM B370 - 12, Specification for Copper Sheet and Strip for Building Construction.
  - .8 ASTM D523 - 14(2018), Test Method for Specular Gloss.
  - .9 ASTM D822/ D822M - 13, Practice for Conducting Tests on Paint and Related Coatings and Materials Using Filtered Open-Flame Carbon Arc Light and Water Exposure Apparatus.
- .3 Canadian Roofing Contractors Association (CRCA).
  - .1 Roofing Specifications Manual.
- .4 Canadian Standards Association (CSA)
  - .1 CSA A123.3-05 (R2015), Asphalt or Tar Saturated Roofing Felt.
  - .2 CAN/CSA-A440S1-17, Windows.
  - .3 CSA B111-1974 (R2003), Wire Nails, Spikes and Staples.
- .5 Canadian General Standards Board (CGSB)
  - .1 CAN/CGSB-37.5-M89, Cutback Asphalt Plastic Cement.
  - .2 CAN/CGSB-51.32-M77, Sheathing, Membrane, Breather Type.
  - .3 CAN/CGSB-93.1-M85, Sheet, Aluminum Alloy, Prefinished, Residential.

## 1.4 Samples

- .1 Submit shop drawings in accordance with General Requirements.
- .2 Submit duplicate 300mm x 300mm samples of each type of sheet metal material, colour and finish.

---

**PART 2 - PRODUCTS**

## 2.1 Sheet Metal Materials

- .1 Zinc coated steel sheet: 0.70mm thickness, commercial quality to ASTM A 653/A 653M, with Z275 designation zinc coating.
- .2 Precoated Steel Sheet:
  - .1 Base metal thickness: 0.70mm.
  - .2 Finish: baked enamel, applied by a continuous sheet steel coating plant;
    - .1 WeatherX™ coating system, as provided with VicWest products.
    - .2 Pre-coat 8000 Series.
  - .3 Colour: To be selected by Consultant from manufacturer's full stock colour range.

## 2.2 Accessories

- .1 Isolation coating: alkali resistant bituminous paint.
- .2 Plastic cement: to CAN/CGSB 37.5-M89.
- .3 Underlay for metal flashing: No. 15 perforated asphalt felt to CSA A123.3.
- .4 Cleats: of same material, and temper as sheet metal, minimum 50 mm wide. Thickness same as sheet metal being secured.
- .5 Fasteners (exposed): #10 hex head cadmium plated with neoprene and solid washers by Atlas Bolt or approved equal complete with caps for screw heads to match colour of flashing.
- .6 Fasteners (concealed): of same material as sheet metal, to CSA B111, ring thread flat head roofing nails of length and thickness suitable for metal flashing application.
- .7 Masonry Fasteners: Tapcon, Gripcon or Rawl spike sized to penetrate masonry 38mm minimum.
- .8 Washers: of same material as sheet metal, 1 mm thick with rubber packings.
- .9 Sealant and backer rods: in accordance with Section 07 92 10 - Joint Sealing, colour to match materials being caulked.
- .10 Solder: to ASTM B 32, alloy composition.
- .11 Flux: rosin, cut hydrochloric acid, or commercial preparation suitable for materials to be soldered.
- .12 Touch-up paint: as recommended by prefinished material manufacturer.

## 2.3 Fabrication

- .1 Fabricate metal flashings and other sheet metal work in accordance with applicable CRCA 'FL' series details.
- .2 Form pieces in 2400mm maximum lengths. Make allowance for expansion at joints.
- .3 Hem exposed edges on underside 12mm. Mitre and seal corners with sealant.
- .4 Form sections square, true and accurate to size, free from distortion and other defects detrimental to appearance or performance.
- .5 Supply accessories for installation of sheet work of same materials to which they will be used.
- .6 Apply isolation coating to metal surfaces to be embedded in concrete or mortar.
- .7 Seams shall be "slip lock type" that permit adequate movement without resulting in deformation or loosening of metal flashings. Lapped joints or exposed raw edges will not be accepted. Exposed edges shall be "doubled back" at least 12.5mm. At eaves, parapets, etc., metal shall be hooked over continuous starter strips that are a minimum two (2) gauges thicker than the metal used for flashing. Secure starter strips at 300mm O.C. or closer as required.
- .8 Where metal terminates under fascia boards, secure metal at 600mm O.C. using specified fasteners. At curbs to openings or at sleepers, etc., provide lock or standing seams at corners. Solder mitred corners or form standing seams.

- .9 Where metal flashings enter reglets, ensure reglet is minimum 19mm deep and 10mm wide. Metal flashing portion that enters reglet shall extend the full depth and be complete with 10mm return upstand to permit proper securement in the reglet. Secure metal flashing in reglets at 600mm O.C. and further secure metal to vertical surface at locks.

#### 2.4 Metal Flashings

- .1 Form cap and counter flashings, copings and fascias from specified precoated sheet steel, to profiles indicated on Drawings.

#### 2.5 Pans

- .1 Form pans to receive roofing plastic from sheet metal with minimum 75mm upstand above finished roof and 100mm continuous flanges with no open corners. Solder joints. Make pans minimum 50mm wider than member passing through roof membrane.

#### 2.6 Reglets

- .1 Form recessed reglets of specified sheet metal to be built-in for base flashings in accordance with CRCA FL series details.  
.2 Ensure reglet is minimum 19mm deep and 10mm wide.

### **PART 3 - EXECUTION**

#### 3.1 Installation

- .1 Sheet metal work shall be of the highest quality and installed with the best trade practice and in accordance with CRCA FL series details.  
.2 All flashings shall be installed in perfectly straight lines. Irregular or badly fitted work will not be accepted. At raised eave details, starter strips will be used. Exposed fastenings will only be permitted where concealed fastening is impossible. Neoprene washers shall be used at exposed fastenings.  
.3 New metal flashings and fascias shall be 26 gauge precoated steel sheet. In all cases the bottom edge of the new metal shall meet the roof surface.  
.4 At wall flashing details with "through wall" metal counterflashings or Mechanical walls with "lip" metal, the upper edge of the new wall face metal shall extend to a point 6mm below the through wall metal joint. The upper edge of the new face metal counterflashing shall be fastened to the wall using appropriate fasteners 250mm O.C. Fasteners shall be placed such that they are covered by the existing through wall metal.  
.5 At all curb flashing details install new metal counterflashing, with the upper edge mechanically fastened at 300mm O.C. behind the existing lip metal.  
.6 At sleepers, install new metal counterflashing to envelope sleeper.  
.7 Provide underlay under sheet metal. Secure in place and lap joints 100mm.  
.8 Counterflash bituminous flashings at intersections of roof with vertical surfaces and curbs. Flash joints using S-lock forming tight fit over continuous hook strips.  
.9 Lock end joints and caulk with sealant.  
.10 Insert metal flashing into reglets and under cap flashing to form weather tight junction.  
.11 Turn top edge of flashing into recessed reglet or mortar joint minimum of 20mm. Wedge flashings securely into reglets or mortar joints with lead wedges at 200mm O.C. Set wedges 6mm in from face of masonry.  
.12 Caulk flashing at reglet and cap flashing with sealant to provide a continuous waterproof seal. Ensure caulking bonds to intended surface and is tooled to provide even finish. Use colour to match materials being caulked.

.13 Install pans around items projecting through roof membrane.

3.2 Scuppers

.1 Install scuppers to allow for roof drainage as indicated on Drawings.

END OF SECTION

## **PART 1 - GENERAL**

### 1.1 General

- .1 Conform to Division 01 – General Requirements.

### 1.2 References

- .1 Underwriters Laboratories of Canada (ULC)
  - .1 CAN/ULC-S101-14.
  - .2 CAN/ULC-S102-10.

### 1.3 Test Reports

- .1 Submit product data including certified copies of test reports verifying fireproofing applied to substrate as constructed on project will meet or exceed requirements of Specification.
- .2 Submit test results in accordance with CAN/ULC-S101 for fire endurance and CAN/ULC-S102 for surface burning characteristics.
- .3 For assemblies not tested and rated, submit proposals based on related designs using accepted fireproofing design criteria.

### 1.4 Samples

- .1 Submit samples in accordance with Section 01 33 00 – Submittal Procedures.
- .2 Submit applicable U.L.C. Design Numbers for all conditions required on this project, including applicable acceptance information from U.L.C. for the materials specified. Proof of total compliance rests with the fireproofing applicator.

### 1.5 Mock Up

- .1 Apply fireproofing to approximately 10m<sup>2</sup> area of surface to be treated.
- .2 Allow 24 hours for inspection of mock-up by Consultant before proceeding with fireproofing work.

### 1.6 Protection

- .1 At outdoor temperatures less than 5°C, ensure that a 5°C air and substrate temperature is maintained during and for 24 hours after application. Ensure that natural ventilation to properly dry the fireproofing during and subsequent to its application is provided. In enclosed areas lacking openings for natural ventilation, ensure that interior air is circulated and exhausted to the outside.
- .2 Provide temporary enclosures to prevent spray from contaminating air beyond application area.
- .3 Protect adjacent surfaces and equipment from damage by overspray, fall-out, and dusting of fireproofing materials.

---

## **PART 2 - PRODUCTS**

### 2.1 Sprayed Fireproofing:

- .1 Sprayed fireproofing: non-combustible, spray-applied, portland cement-based fire resistive material, factory-mixed powder, mixed with water prior to application, providing fire resistance ratings indicated on Drawings.
  - .1 Acceptable Materials: "A/D Fire Protection Systems Southwest Fireproofing Type 5" by A/D Fire Protection Systems, "Cafco 300" by Isolotek International, Monokote Retro-Guard RG by GCP Applied Technologies.
- .2 Auxiliary Materials:
  - .1 Primer/ Adhesive: Manufacturer's standard adhesive designed for use with specified fireproofing.
  - .2 Water: clean, potable.

## **PART 3 - EXECUTION**

### 3.1 Preparation

- .1 Substrate shall be free of material, which would impair bond.
- .2 Verify that painted substrates are compatible and have suitable bonding characteristics to receive fireproofing.
- .3 Remove incompatible materials.
- .4 Ensure that items required to penetrate fireproofing are placed before installation of fireproofing.
- .5 Ensure that ducts, piping, equipment, or other items which would interfere with application of fireproofing are not positioned until fireproofing work is completed.

### 3.2 Application

- .1 Apply bonding adhesive or primer to substrate if recommended by manufacturer.
- .2 Apply fireproofing to correspond with tested assemblies, or acceptable calculation procedures to provide following fire resistance ratings.
- .3 Apply fireproofing over substrate, building up to required thickness to cover substrate with monolithic blanket of uniform density and texture.
- .4 Apply fireproofing directly to structural steel without use of expanded lath.
- .5 Tamp smooth, surfaces as indicated.
- .6 Apply curing compound **with blue tint** to surface of cementitious fireproofing as required by manufacturer in areas where sprayed fireproofing will not have a finish paint coat (i.e. above acoustic tile ceilings).
- .7 Apply sealer to surface of mineral fibre fireproofing as required by manufacturer in ventilation plenums, where fireproofing is to be painted and as indicated.

### 3.3 Patching

- .1 Patch damage to fireproofing caused by testing or by other trades, including attachment of partition framing, before fireproofing is concealed, or if exposed, before final inspection.

END OF SECTION

## **PART 1 - GENERAL**

### 1.1 General

- .1 Conform to Division 01 – General Requirements.

### 1.2 Related Work

- .1 Fire stopping and smoke seals within mechanical assemblies (i.e. inside ducts, dampers) and electrical assemblies (i.e. inside cable trays) are specified in Division 21 through 28 respectively.

### 1.3 References

- .1 Underwriter's Laboratories of Canada (ULC)
  - .1 ULC-S115-05, Fire Test of Firestop Systems.

### 1.4 Samples

- .1 Submit samples in accordance with Section 01 33 00 - Submittal Procedures.
- .2 Submit duplicate 300mm x 300mm samples showing actual firestop material proposed for project.

### 1.5 Shop Drawings

- .1 Submit shop drawings in accordance with Section 01 33 00 - Submittal Procedures.
- .2 Submit shop drawings to show proposed material, reinforcement, anchorage, fastenings and method of installation. Construction details should accurately reflect actual job conditions.

### 1.6 Product Data

- .1 Submit product data in accordance with Section 01 33 00 - Submittal Procedures.
- .2 Submit manufacturer's product data for materials and prefabricated devices, providing descriptions are sufficient for identification at job site. Include manufacturer's printed instructions for installation.

## **PART 2 - PRODUCTS**

### 2.1 Materials

- .1 Fire stopping and smoke seal systems: in accordance with ULC-S115.
  - .1 Asbestos-free materials and systems capable of maintaining an effective barrier against flame, smoke and gases in compliance with requirements of ULC-S115 and not to exceed opening sizes for which they are intended.
  - .2 Firestop system rating: as indicated on Drawings for each condition.
- .2 Service penetration assemblies: certified by ULC in accordance with ULC-S115 and listed in ULC Guide No.40 U19.
- .3 Service penetration firestop components: certified by ULC in accordance with ULC-S115 and listed in ULC Guide No.40 U19.13 and ULC Guide No.40 U19.15 under the Label Service of ULC.
- .4 Fire-resistance rating of installed fire stopping assembly in accordance with NBC.

- .5 Fire stopping and smoke seals at openings intended for ease of re-entry such as cables: elastomeric seal.
- .6 Fire stopping and smoke seals at openings around penetrations for pipes, ductwork and other mechanical items requiring sound and vibration control: elastomeric seal.
- .7 Primers: to manufacturer's recommendation for specific material, substrate, and end use.
- .8 Water (if applicable): potable, clean and free from injurious amounts of deleterious substances.
- .9 Damming and backup materials, supports and anchoring devices: to manufacturer's recommendations, and in accordance with tested assembly being installed as acceptable to authorities having jurisdiction.
- .10 Sealants for vertical joints: non-sagging.

### **PART 3 - EXECUTION**

#### 3.1 Preparation

- .1 Examine sizes and conditions of voids to be filled to establish correct thicknesses and installation of materials. Ensure that substrates and surfaces are clean, dry and frost free.
- .2 Prepare surfaces in contact with fire stopping materials and smoke seals to manufacturer's instructions.
- .3 Maintain insulation around pipes and ducts penetrating fire separation.
- .4 Mask where necessary to avoid spillage and over coating onto adjoining surfaces; remove stains on adjacent surfaces.

#### 3.2 Installation

- .1 Install fire stopping and smoke seal material and components in accordance with ULC certification and manufacturer's instructions.
- .2 Seal holes or voids made by through penetrations, poke-through termination devices, and unpenetrated openings or joints to ensure continuity and integrity of fire separation are maintained.
- .3 Provide temporary forming as required and remove forming only after materials have gained sufficient strength and after initial curing.
- .4 Tool or trowel exposed surfaces to a neat finish.
- .5 Remove excess compound promptly as work progresses and upon completion.

#### 3.3 Inspection

- .1 Notify Consultant when ready for inspection and prior to concealing or enclosing firestopping materials and service penetration assemblies.

#### 3.4 Schedule

- .1 Firestop and smoke seal at:
  - .1 Penetrations through fire-resistance rated masonry, concrete, and gypsum board partitions and walls.
  - .2 Top of fire-resistance rated masonry and gypsum board partitions.
  - .3 Intersection of fire-resistance rated masonry and gypsum board partitions.
  - .4 Control and sway joints in fire-resistance rated masonry and gypsum board partitions and walls.
  - .5 Penetrations through fire-resistance rated floor slabs, ceilings and roofs.
  - .6 Openings and sleeves installed for future use through fire separations.
  - .7 Around mechanical and electrical assemblies penetrating fire separations.

- .8 Rigid ducts: greater than 129 cm<sup>2</sup>: fire stopping to consist of bead of fire stopping material between retaining angle and fire separation and between retaining angle and duct, on each side of fire separation.

3.5 Clean Up

- .1 Remove excess materials and debris and clean adjacent surfaces immediately after application.
- .2 Remove temporary dams after initial set of firestopping and smoke seal materials.

END OF SECTION

---

## **PART 1 - GENERAL**

### 1.1 General

- .1 Conform to Division 01 - General Requirements.

### 1.2 References

- .1 CAN/CGSB-19.1-M87, Putty, Linseed Oil Type.
- .2 CAN/CGSB-19.2-M87, Glazing Compound, Nonhardening, Modified Oil Type.
- .3 CGSB 19-GP-5M-76, Sealing Compound, One Component, Acrylic Base, Solvent Curing.
- .4 CAN/CGSB-19.6-M87, Caulking Compound, Oil Base.
- .5 CAN/CGSB-19.13-M87, Sealing Compound, One-component, Elastomeric, Chemical Curing.
- .6 CGSB 19-GP-14M-76, Sealing Compound, One Component, Butyl-polyisobutylene Polymer Base, Solvent Curing.
- .7 CAN/CGSB-19.17-M90, One-Component Acrylic Emulsion Base Sealing Compound.
- .8 CAN/CGSB-19.18-M87, Sealing Compound, One Component, Silicone Base, Solvent Curing.
- .9 CAN/CGSB-19.20-M87, Cold-applied Sealing Compound, Aviation Fuel-resistant.
- .10 CAN/CGSB-19.21-M87, Sealing and Bedding Compound Acoustical.
- .11 CAN/CGSB-19.22-M89, Mildew Resistant, Sealing Compound for Tubs and Tiles.
- .12 CAN/CGSB-19.24-M90, Multi-component, Chemical Curing Sealing Compound.

### 1.3 Samples

- .1 Submit samples in accordance with General Requirements.
- .2 Submit duplicate samples of each type of material and colour.

### 1.4 Mock-up

- .1 Construct mock-up in accordance with General Requirements.
- .2 Construct mock-up to show location, size, shape and depth of joint s complete with back-up material, primer, caulking and sealant. Mock-up may be part of finished work.
- .3 Allow 24 hours for inspection of mock-up by Consultant before proceeding with sealant work.

### 1.5 Delivery, Storage and Handling

- .1 Deliver, handle, store and protect materials in accordance with General Requirements.
- .2 Deliver and store materials in original wrappings and containers with manufacturer's seals and labels, intact. Protect from freezing, moisture, water and contact with ground or floor.

### 1.6 Environmental and Safety Requirements

- .1 Comply with requirements of Workplace Hazardous Materials Information System (WHMIS) regarding use, handling, storage, and disposal of hazardous materials; and regarding labelling and provision of material safety data sheets acceptable to Labour Canada.
- .2 Conform to manufacturer's recommended temperatures, relative humidity, and substrate moisture content for application and curing of sealants including special conditions governing use.

---

## **PART 2 - PRODUCTS**

### 2.1 Sealant Materials

- .1 Sealants and caulking compounds must:
  - .1 meet or exceed all applicable governmental and industrial safety and performance standards; and
  - .2 be manufactured and transported in such a manner that all steps of the process, including the disposal of waste products arising there from, will meet the requirements of all applicable governmental acts, by laws and regulations including, for facilities located in Canada, the fisheries Act and the Canadian Environmental Protection Act (CEPA).
- .2 Sealant and caulking compounds must not be formulated or manufactured with: aromatic solvents, fibrous talc or asbestos, formaldehyde, halogenated solvents, mercury, lead, cadmium, hexavalent chromium, barium or their compounds, except barium sulfate.
- .3 Sealant and caulking compounds must not contain a total of volatile organic compounds (VOCs) in excess of 5% by weight as calculated from records of the amounts of constituents used to make the product.
- .4 Sealant and caulking compounds must be accompanied by detailed instructions for proper application so as to minimize health concerns and maximize performance, and information describing proper disposal methods.
- .5 Caulking that emits strong odours, contains toxic chemicals or is not certified as mould resistant shall not be used in air handling units.
- .6 When low toxicity caulks are not possible, confine usage to areas which off gas to the exterior, are contained behind air barriers, or are applied several months before occupancy to maximize off-gas time.
- .7 The manufacturing process must adhere to Lifecycle Assessment Standards as per ISO 14040/14041 LCA Standards (to be published by 1998), CSA Z760-94 LCA Standards.
- .8 Sealants acceptable for use on this project must be listed on CGSB Qualified Products List issued by CGSB Qualification Board for Joint Sealants. Where sealants are qualified with primers use only these primers.

### 2.2 Sealant Material Designations

- .1 Urethanes One Part.
  - .1 Non-Sag to CAN/CGSB-19.13, Type 2, colour as selected by Consultant.
- .2 Silicones One Part.
  - .1 To CAN/CGSB-19.22 (Mildew resistant).
- .3 Acrylic Latex One Part.
  - .1 To CAN/CGSB-19.17.
- .4 Acoustical Sealant.
  - .1 To CAN/CGSB-19.21.
- .5 Preformed Compressible and Non-Compressible back-up materials.
  - .1 Polyethylene, Urethane, Neoprene or Vinyl Foam.
    - .1 Extruded closed cell foam backer rod.
    - .2 Size: oversize 30 to 50 %.
  - .2 Bond Breaker Tape.
    - .1 Polyethylene bond breaker tape which will not bond to sealant.

### 2.3 Sealant Selection

- .1 Exterior: Urethane.
- .2 Interior control and expansion joints: Silicone.
- .3 Perimeters of interior frames and millwork: Acrylic Latex.

- .4 Perimeter of bath fixtures (e.g. sinks, tubs, urinals, stools, waterclosets, basins, vanities):  
Sealant type: Mildew Resistant Silicone.
- .5 Exposed interior control joints in drywall: Acrylic Latex.
- .6 Perimeter of walls to ensure continuity of sound proofing: Acoustical.

#### 2.4 Joint Cleaner

- .1 Non-corrosive and non-staining type, compatible with joint forming materials and sealant recommended by sealant manufacturer.
- .2 Primer: as recommended by manufacturer.

### **PART 3 - EXECUTION**

#### 3.1 Protection

- .1 Protect installed work of other trades from staining or contamination.

#### 3.2 Preparation of Joint Surfaces

- .1 Examine joint sizes and conditions to establish correct depth to width relationship for installation of backup materials and sealants; depth ratio  $\frac{1}{2}$  of joint width with minimum width and depth of 6mm, maximum width 12mm
- .2 Clean bonding joint surfaces of harmful matter substances including dust, rust, oil grease, and other matter which may impair work.
- .3 Do not apply sealants to joint surfaces treated with sealer, curing compound, water repellent, or other coatings unless tests have been performed to ensure compatibility of materials. Remove coatings as required.
- .4 Ensure joint surfaces are dry and frost free.
- .5 Prepare surfaces in accordance with manufacturer's directions.

#### 3.3 Priming

- .1 Where necessary to prevent staining, mask adjacent surfaces prior to priming and caulking.
- .2 Prime sides of joints in accordance with sealant manufacturer's instructions immediately prior to caulking.

#### 3.4 Backup Material

- .1 Apply bond breaker tape where required to manufacturer's instructions.
- .2 Install joint filler to achieve correct joint depth and shape, with approximately 30% compression.

#### 3.5 Mixing

- .1 Mix materials in strict accordance with sealant manufacturer's instructions.

#### 3.6 Application

- .1 Sealant.
  - .1 Apply sealant in accordance with manufacturer's written instructions.
  - .2 Mask edges of joint where irregular surface or sensitive joint border exists to provide neat joint.

- .3 Apply sealant in continuous beads.
- .4 Apply sealant using gun with proper size nozzle.
- .5 Use sufficient pressure to fill voids and joints solid.
- .6 Form surface of sealant with full bead, smooth, free from ridges, wrinkles, sags, air pockets, embedded impurities.
- .7 Tool exposed surfaces before skinning begins to give slightly concave shape.
- .8 Remove excess compound promptly as work progresses and upon completion.
- .2 Curing.
  - .1 Cure sealants in accordance with sealant manufacturer's instructions.
  - .2 Do not cover up sealants until proper curing has taken place.
  - .3 Cleanup.
    - .1 Clean adjacent surfaces immediately and leave work neat and clean.
    - .2 Remove excess and droppings, using recommended cleaners as work progresses.
    - .3 Remove masking tape after initial set of sealant.

END OF SECTION

## **PART 1 - GENERAL**

### 1.1 General

- .1 Conform to Division 01 – General Requirements.

### 1.2 Related Sections

- .1 Section 07 92 10 – Joint Sealing.
- .2 Section 08 71 10 – Finish Hardware.
- .3 Section 08 80 50 – Glazing.
- .4 Section 09 91 00 – Painting.

### 1.3 References

- .1 Canadian General Standards Board (CGSB).
  - .1 CAN/CGSB-1.181-99, Ready-Mixed Organic Zinc-Rich Coating.
  - .2 CGSB 41-GP-19MA, Rigid Vinyl Extrusions for Windows and Doors.
  - .3 CAN/CGSB-51.20-M87, Thermal Insulation, Polystyrene, Boards and Pipe Covering.
  - .4 CGSB 51-GP-21M-78, Thermal Insulation, Urethane and Isocyanurate, Unfaced.
- .2 Canadian Standards Association (CSA).
  - .1 CSA A101-M1983, Thermal Insulation, Mineral Fibre, for Buildings.
  - .2 CAN/CSA-G40.21-13 (R2018), Structural Quality Steels.
  - .3 CSA W59-13, Welded Steel Construction (Metal Arc Welding).
- .3 Canadian Steel Door and Frame Manufacturers' Association, (CSDFMA).
  - .1 CSDFMA, Specifications for Commercial Steel Doors and Frames.
  - .2 CSDFMA, Recommended Selection and Usage Guide for Commercial Steel Doors.
- .4 National Fire Protection Association (NFPA).
  - .1 NFPA 80-2016, Fire Doors and Windows.
  - .2 NFPA 252-2017, Door Assemblies, Fire Tests of.
- .5 Underwriters' Laboratories of Canada (ULC).
  - .1 CAN/ULC4-S104-15, Fire Tests of Door Assemblies.
  - .2 CAN4-S105-16, Fire Door Frames.

### 1.4 Shop Drawings

- .1 Submit shop drawings in accordance with Section 01 33 00 - Submittal Procedures.
- .2 Indicate each type of door, material, steel core thicknesses, mortises, reinforcements, location of exposed fasteners, openings, glazed, arrangement of hardware fire rating and finishes.
- .3 Indicate each type frame material, core thickness, reinforcements, glazing stops, location of anchors and exposed fastenings and fire rating finishes.
- .4 Include schedule identifying each unit, with door marks and numbers relating to numbering on drawings and door schedule.

### 1.5 Requirements of Regulatory Agencies

- .1 Steel fire rated doors and frames: labelled and listed by an organization accredited by Standards Council of Canada in conformance with CAN4-S104M NFPA 252 for ratings specified or indicated.

## **PART 2 - PRODUCTS**

### 2.1 Materials

- .1 Hot dipped galvanized steel sheet: to ASTM A 653M; minimum base steel thickness in accordance with CSDFMA Table 1 – Thickness for Component Parts.
- .2 Reinforcement channel: to CAN/CSA-G40.21, Type 44W, coating designation to ASTM A 653M, ZF75.

### 2.2 Door Core Materials

- .1 Honeycomb construction:
  - .1 Structural small cell, 24.5mm maximum kraft paper 'honeycomb', weight: 36.3 kg per ream minimum, density: 16.5 kg/m<sup>3</sup> minimum sanded to required thickness.
  - .2 Stiffened: face sheets welded, insulated core.
    - .1 Expanded polystyrene: CAN/CGSB-51.20, density 16 to 32 kg/m<sup>3</sup>.

### 2.3 Adhesives

- .1 Honeycomb cores and steel components: heat resistant, spray grade, resin reinforced neoprene/rubber (polychloroprene) based, low viscosity, contact cement.
- .2 Polystyrene and polyurethane cores: heat resistant, epoxy resin based, low viscosity, contact cement.

### 2.4 Primers

- .1 Touch-up prime CAN/CGSB-1.181.

### 2.5 Paint

- .1 Metal doors and frames shall be field painted in accordance with Sections 09 91 00. Weatherstrips shall be protected from paint. Finish shall be free of scratches or other blemishes.

### 2.6 Accessories

- .1 Door silencers: single stud rubber/ neoprene type.
- .2 Interior top and bottom caps: steel.
- .3 Fabricate glazing stops as formed channel, minimum 16mm height; 0.9mm (20g) base thickness sheet steel with ZF75 (interior) zinc finish to ASTM A 653M, accurately fitted, butted at corners and fastened to frame sections with counter-sunk oval head sheet metal screws.
- .4 Metallic paste filler: to manufacturer's standard.
- .5 Fire labels: metal rivetted.
- .6 Sealant: Refer to Section 07 92 10.
- .7 Glazing: Refer to Section 08 80 50.

### 2.7 Frames Fabrication General

- .1 Fabricate frames in accordance with CSDFMA specifications.
- .2 Fabricate frames to profiles and maximum face sizes as indicated.
- .3 Interior frames: 1.5mm (16ga) welded construction, ZF 75 (A25) finish.
- .4 Blank, reinforce, drill and tap frames for mortised, templated hardware, using templates provided by finish hardware supplier. Reinforce frames for surface mounted hardware.

- .5 Protect mortised cutouts with steel guard boxes.
- .6 Prepare frame for door silencers, 3 for single door, 2 at head for double door.
- .7 Manufacturer's nameplates to be located on hinge side of frame.
- .8 Conceal fastenings except where exposed fastenings are indicated.
- .9 Provide factory-applied touch up primer at areas where zinc coating has been removed during fabrication.

## 2.8 Frame Anchorage

- .1 Provide appropriate anchorage to floor and wall construction.
- .2 Locate each wall anchor immediately above or below each hinge reinforcement on hinge jamb and directly opposite on strike jamb.
- .3 Provide 2 anchors for rebate opening heights up to 1520mm and 1 additional anchor for each additional 760mm of height or fraction thereof.

## 2.9 Frames: Welded Type

- .1 Welding in accordance with CSA W59.
- .2 Accurately mitre or mechanically joint frame product and securely weld on inside of profile.
- .3 Cope accurately and securely weld butt joints of mullions, transom bars, centre rails and sills.
- .4 Grind welded joints and corners to a flat plane, fill with metallic paste and sand to uniform smooth finish.
- .5 Securely attach floor anchors to inside of each jamb profile.
- .6 Weld in 2 temporary jamb spreaders per frame to maintain proper alignment during shipment.

## 2.10 Door Fabrication General

- .1 Doors: swing type, flush, with provision for glass and/or louvre/grille openings as indicated.
- .2 Interior doors: honeycomb construction.
- .3 Fabricate doors with longitudinal edges locked seam welded. Seams: grind welded joints to a flat plane, fill with metallic paste filler and sand to a uniform smooth finish.
- .4 Blank, reinforce, drill doors and tap for mortised, templated hardware.
- .5 Reinforce doors where required, for surface mounted hardware. Provide flush PVC top caps to exterior doors. Provide inverted, recessed, spot welded channels to top and bottom of interior doors.
- .6 Provide factory-applied touch-up primer at areas where zinc coating has been removed during fabrication.
- .7 Provide fire labelled doors for those openings requiring fire protection ratings, as scheduled. Test such products in strict conformance with CAN4-S104, ASTM E 152 or NFPA 252 and list by nationally recognized agency having factory inspection service and construct as detailed in Follow-Up Service Procedures/Factory Inspection Manuals issued by listing agency to individual manufacturers.
- .8 Manufacturer's nameplates to be located on hinge side of door.

## 2.11 Doors: Core Construction

- .1 Form each face sheet for interior doors from 1.5mm (16ga) sheet steel with honeycomb - core laminated under pressure to face sheets.

### **PART 3 - EXECUTION**

#### 3.1 Installation General

- .1 Install labelled steel fire rated doors and frames to NFPA 80 except where specified otherwise.
- .2 Install doors and frames to CSDFMA Installation Guide.

#### 3.2 Frame Installation

- .1 Set frames plumb, square, level and at correct elevation.
- .2 Secure anchorages and connections to adjacent construction.
- .3 Brace frames rigidly in position while building-in. Install temporary horizontal wood spreader at third points of door opening to maintain frame width. Provide vertical support at centre of head for openings over 1200mm wide. Remove temporary spreaders after frames are built-in.
- .4 Make allowances for deflection of structure to ensure structural loads are not transmitted to frames.
- .5 Caulk perimeter of frames between frame and adjacent material.
- .6 Maintain continuity of air barrier and vapour retarder.

#### 3.3 Door Installation

- .1 Install doors and hardware in accordance with hardware templates and manufacturer's instructions. Typical hardware may include three butt hinges or continuous hinges, floor or wall stops, panic or mortise passage/ locksets, door closers, weatherstripping, kick plates, signs and rebated automatic door bottoms.
- .2 Install grilles as indicated on Drawings.
- .3 Provide even margins between doors and jambs and doors and finished floor and thresholds as follows.
  - .1 Hinge side: 1.0mm.
  - .2 Latchside and head: 1.5mm.
  - .3 Finished floor, top of flooring, noncombustible sill and thresholds: 13mm.
- .4 Adjust operable parts for correct function.

#### 3.4 Finish Repairs

- .1 Touch up with primer finishes damaged during installation.
- .2 Fill exposed frame anchors and surfaces with imperfections with metallic paste filler and sand to a uniform smooth finish.

#### 3.5 Glazing

- .1 Install glazing for doors and frames in accordance with Section 08 80 50 – Glazing.

END OF SECTION

---

**PART 1 - GENERAL**

1.1 General

- .1 Conform to Division 01 – General Requirements.

1.2 Related Sections

- .1 Section 07 92 10 – Joint Sealing.
- .2 Section 08 80 50 – Glazing.
- .3 Division 26 – Electrical.

1.3 References

- .1 Aluminum Association Designation System for Aluminum Finishes.
- .2 American Society for Testing and Materials (ASTM)
  - .1 ASTM E330 /E330m - 14, Test Method for Structural Performance of Exterior Windows, Curtain Walls, and Doors by Uniform Static Air Pressure Difference.
- .3 Canadian General Standards Board (CGSB)
  - .1 CAN/CGSB 1.40-97, Primer, Structural Steel, Oil Alkyd Type.
  - .2 CAN/CGSB-12.1-M90, Tempered or Laminated Safety Glass.
- .4 Canadian Standards Association (CSA)
  - .1 CAN/CSA-G40.21-13 (R2018), Structural Quality Steels.
  - .2 CAN/CSA G164-M92 (R2003), Hot Dip Galvanizing of Irregularly Shaped Articles.

1.4 Approved Manufacturers

- .1 To establish a standard for tendering purposes, the Drawings are based upon Kawneer Company of Canada Limited;
  - .1 Exterior Doors/ Screens: 500 Heavy Wall Entrance / Trifab VG 451.
  - .2 Interior Doors/ Screens: 500 Heavy Wall Entrance / Trifab VG 450.
- .2 The following manufacturers are approved, subject to total compliance with this Specification:
  - .1 Alumicor Limited.
  - .2 Sherwood Windows Group
  - .3 Aerloc Industries Inc.

1.5 Shop Drawings

- .1 Submit shop drawings in accordance with Section 01 33 00 - Submittal Procedures.
- .2 Indicate each type of door and frame, extrusion profiles, method of assembly, section and hardware reinforcement, locations of exposed fasteners, finishes and location of manufacturer's nameplates.
- .3 Submit catalogue details for each type of door and frame illustrating profiles, dimensions and methods of assembly.

1.6 Samples

- .1 Submit samples in accordance with Section 01 33 00 - Submittal Procedures.
- .2 Submit one 300mm x 300mm corner sample of each type door and frame.

1.7 Closeout Submittals

- .1 Provide maintenance data for cleaning and maintenance of aluminum finishes for incorporation into manual specified in Section 01 78 10 – Closeout Submittals and Requirements.

1.8 Protection

- .1 Apply temporary protective coating to finished surfaces. Remove coating after erection. Do not use coatings that will become hard to remove or leave residue.
- .2 Leave protective covering in place until final cleaning of building.

1.9 Warranty

- .1 Provide a written warranty, signed and issued in the name of the Owner and Project, stating that the Contractor warrants aluminum doors, frames and screens against leakage, defects and malfunction under normal usage in accordance with GC 12.3 as amended by the Supplementary General Conditions but for a period of three years.

**PART 2 - PRODUCTS**

2.1 Materials

- .1 Aluminum extrusions: Aluminum Association alloy AA6063-T5 anodizing quality.
- .2 Sheet aluminum: Aluminum Association alloy AA1100-H14 anodizing quality.
- .3 Steel reinforcement: to CAN/CSA-G40.21, grade 300 W.
- .4 Fasteners: aluminum, cadmium plated steel or stainless steel, finished to match adjacent material.
- .5 Weatherstrip: Metal backed wool pile.
- .6 Hardware: Supplied under hardware allowance and installed by this Section.
- .7 Door bumpers: black neoprene.
- .8 Isolation coating: bituminous paint.
- .9 Glass and glazing materials: Refer to Section 08 80 50.
  - .1 Glass in exterior units: 6mm thick (each pane) insulated tempered tinted heat absorbing glass.
  - .2 Glass in interior units: 6mm thick tempered safety glass.
- .10 Sealants: Refer to Section 07 92 10.

2.2 Aluminum Doors

- .1 Construct doors of porthole extrusions with minimum wall thickness of 3.0mm.
- .2 Door stiles nominal 127mm wide, plus or minus 6mm; meeting stiles to be bevelled.
- .3 Top rail nominal 127mm high, plus or minus 6mm.
- .4 Bottom rail nominal 165mm high, plus or minus 6mm.
- .5 Intermediate rail nominal 215mm high, excluding stops, plus or minus 6mm.
- .6 Reinforce mechanically-joined corners of doors to produce sturdy door unit.
- .7 Glazing stops: interlocking snap-in type for dry glazing. Exterior stops: tamperproof type.
- .8 Provide thermally insulated doors for exterior, and interior locations noted on Door Schedule.
- .9 Hardware: As provided by hardware allowance, including pulls, pushes, automatic door operators, continuous hinges, cylinder locks, door stops, door closures, exit devices.

2.3 Aluminum Frames

- .1 Construct frames of aluminum extrusions with minimum wall thickness of 4.8mm, to provide structural strength to meet specified performance requirements, size 45mm x 115mm for flush glazing.
- .2 Frame for doors and screens to be by same manufacturer as aluminum doors.

## 2.4 Aluminum Finishes

- .1 Exposed surfaces of aluminum components in accordance with Aluminum Association AA-A41 Class I, 0.018mm minimum thickness; CLEAR ANODIZED.

## 2.5 Steel Finishes

- .1 Finish steel clips and reinforcing steel with zinc coating to CSA G164.

## 2.6 Hardware

- .1 All hardware excluding weatherstripping and sweeps shall be supplied under Hardware Allowance listed in Section 01 21 00.
- .2 Weatherstripping: mohair, replaceable spline type.
- .3 Sweeps: Adjustable, combination extruded aluminum and black solid neoprene.

## 2.7 Fabrication

- .1 Doors and framing to be by same manufacturer.
- .2 Fabricate doors and frames, transom panels and screens to profiles and maximum face sizes as shown.
- .3 Provide structural steel reinforcement as required.
- .4 Design frames and screens in exterior walls to:
  - .1 Accommodate expansion and contraction within service temperature range of 35°C to 75°C.
  - .2 Limit deflection to 1/175th clear span tested to ASTM E330, latest revised edition, under wind loads for building locality as ascertained by NBC Supplement, Climatic Information for Building Design in Canada.
- .5 Make allowances for deflection of structure. Ensure that structural loads are not transmitted to aluminum work.
- .6 Fit intersecting members to flush, hairline, weather tight joints and mechanically fasten together, except where indicated otherwise.
- .7 Conceal fastenings from view. Exposed fastenings where indicated.
- .8 Form cut-outs, recesses, mortising or milling for finishing hardware to templates supplied. Reinforce with aluminum or galvanized steel plates.
- .9 Provide replaceable weatherstripping at exterior and vestibule door openings. Weatherstrip bottom of doors with pile sweep strip applied to door rail.
- .10 Mortise, reinforce, drill and tap doors, frames and reinforcements to receive hardware using templates provided by hardware supplier.
- .11 Isolate aluminum from direct contact with dissimilar metals, concrete and masonry with bituminous paint.

## **PART 3 - EXECUTION**

### 3.1 Installation

- .1 Set frames plumb, square, level at correct elevation in alignment with adjacent work and free from warp, twist and superimposed loads.
- .2 Secure work in required position. Do not restrict thermal movement.
- .3 Isolate from cementitious materials.
- .4 Maintain integrity of vapour retarder and air barrier system within systems installed by this Section and between systems and adjoining construction.
- .5 Install doors and hardware in accordance with hardware templates and manufacturer's instructions.
- .6 Adjust operable parts for correct function.

- .7 Make allowances for deflection of structure to ensure that structural loads are not transmitted to frames.
- 3.2 Glazing
- .1 Glaze aluminum doors and frames in accordance with Section 08 80 50 - Glazing.
- 3.3 Caulking
- .1 Seal joints to provide weathertight seal at outside and air, vapour seal at inside.
  - .2 Apply sealant in accordance with Section 07 92 10 - Joint Sealing. Conceal sealant within the aluminum work except where exposed use is permitted by Consultant. Provide aluminum panning if caulk joint is larger than 6mm.

END OF SECTION

---

**PART 1 - GENERAL**

## 1.1 General

- .1 Conform to Division 01 - General Requirements.

## 1.2 Related Sections

- .1 Section 07 92 10 – Joint Sealing.
- .2 Section 08 50 50 – Aluminum Windows.
- .3 Section 08 80 50 – Glazing.

## 1.3 References

- .1 Aluminum Association Designation System for Aluminum Finishes (AA)-1997
  - .1 DAF 45, Designation System for Aluminum Finishes.
- .2 Architectural Aluminum Manufacturers Association (AAMA)
  - .1 AAMA CW-DG-1-96, Aluminum Curtain Wall Design Guide Manual.
  - .2 AAMA CW-10-97, Curtain Wall Manual #10 Care and Handling of Architectural Aluminum from Shop to Site.
  - .3 AAMA CW-11-85, Curtain Wall Manual - Design Windloads for Buildings and Boundary Layer Wind Tunnel Testing.
  - .4 AAMA T1R-A1-75, Sound Control for Aluminum Curtain Walls and Windows.
  - .5 AAMA 607.1-76, Specifications and Inspection Methods for Clear Anodic Finishes for Architectural Aluminum.
- .3 American Society for Testing and Materials (ASTM)
  - .1 ASTM A36/ A36M - 14, Specification for Structural Steel.
  - .2 ASTM A123/ A123M - 17, Specification for Zinc (Hot-Dip Galvanized) Coatings on Iron and Steel Products.
  - .3 ASTM A167 – 99 (R2009), Specification for Stainless and Heat-Resisting Chromium-Nickel Steel Plate, Sheet, and Strip.
  - .4 ASTM B209 - 14, Specification for Aluminum and Aluminum-Alloy Sheet and Plate Metric.
  - .5 ASTM B221 - 14, Specification for Aluminum-Alloy Extruded Bars, Rods, Wire, Profiles, and Tubes.
  - .6 ASTM E283 – 04(2012), Test Method for Determining the Rate of Air Leakage Through Exterior Windows, Curtain Walls, and Doors Under Specified Pressure Differences Across the Specimen.
  - .7 ASTM E330/ E330M - 14, Test Method for Structural Performance of Exterior Windows, Curtain Walls, and Doors by Uniform Static Air Pressure Difference.
  - .8 ASTM E331 - 00(2016), Test Method for Water Penetration of Exterior Windows, Curtain Walls, and Doors by Uniform Static Air Pressure Difference.
  - .9 ASTM E413 - 16, Classification for Rating Sound Insulation.
- .4 Canadian General Standards Board (CGSB)
  - .1 CAN/CGSB 1.108-M89, Bituminous Solvent Type Paint.
- .5 Canadian Standards Association (CSA)
  - .1 CSA G40.20/G40.21-13 (R2018), General Requirements for Rolled or Welded Structural Quality Steel/Structural Quality Steels.
  - .2 CAN/CSA-G164-M92 (R2003), Hot Dip Galvanizing of Irregularly Shaped Articles.
  - .3 CAN/CSA-S136-01 (R2007), Cold Formed Steel Structural Members.
  - .4 CAN/CSA-S157-05 (R2015), Strength Design in Aluminum.
  - .5 CSA W59.2-M1991(R2008), Welded Aluminum Construction.

#### 1.4 System Description

- .1 Vertical glazed aluminum curtain wall system includes thermally broken tubular aluminum sections with self supporting framing, shop fabricated, factory prefinished, vision glass, glass spandrel infill, column covers, related flashings, anchorage and attachment devices.
- .2 Assembled system to permit re-glazing of individual glass units without requiring removal of structural mullion sections.

#### 1.5 Performance Requirements

- .1 Design and size components to withstand dead and live loads caused by pressure and suction of wind, acting normal to plane of system as calculated in accordance with NBC to a design pressure of 1.44 kPa. as measured in accordance with ASTM E330. Provide all structural reinforcement as required by design.
- .2 Design and size components to withstand seismic loads and sway displacement as calculated in accordance with NBC.
- .3 Limit mullion deflection to L/175; with full recovery of glazing materials.
- .4 Size glass units and glass dimensions to limits established in CAN/CGSB-12.20.
- .5 Provide system to accommodate, without damage to components or deterioration of seals:
  - .1 Movement within system.
  - .2 Movement between system and perimeter framing components.
  - .3 Dynamic loading and release of loads.
  - .4 Deflection of structural support framing.
- .6 Limit air infiltration through assembly to 0.0003 m<sup>3</sup>/s/m<sup>2</sup> of wall area, measured at a reference differential pressure across assembly of 3 Pa as measured in accordance with ASTM E283.
- .7 Vapour seal with interior atmospheric pressure of 25mm sp, 22°C, 40% RH: No failure.
- .8 Water leakage: none, when measured in accordance with ASTM E331.
- .9 Drain water entering joints, condensation occurring in glazing channels, or migrating moisture occurring within system, to the exterior by a weep drainage network.
- .10 Maintain continuous air barrier and vapour retarder throughout assembly, primarily in line with inside pane of glass and heel bead of glazing compound. Position thermal insulation on exterior surface of air barrier and vapour retarder.
- .11 Ensure no vibration harmonics, wind whistles, noises caused by thermal movement, thermal movement transmitted to other building elements, loosening, weakening, or fracturing of attachments or components of system occur.

#### 1.6 Approved Manufacturers

- .1 The Drawings are based upon Alumicor Series 2600 capped curtain wall system. Refer to Drawings for locations of curtain wall types.
- .2 Approved manufacturers are approved, subject to total compliance with this Specification:
  - .1 Kawneer Company of Canada Limited.
  - .2 Sherwood Windows Group.
  - .3 Aerloc Industries Ltd.

#### 1.7 Product Data

- .1 Submit product data in accordance with Section 01 33 00 - Submittal Procedures.
- .2 Prior to shop drawing submittals provide the following:
  - .1 Thermal Simulation: to demonstrate conformance with SB-10. Submit a project specific thermal simulation in general accordance with CSA A440.2, NFRC100-200, NFRC200-2001 and NFRC500-2010.
  - .2 Thermal simulation to be based on the most frequent façade modules.

- 
- .3 Thermal simulation must be completed by or signed as reviewed by a NFRC Certified Simulator listed on [www.nfrccommunity.org/page/CertifiedSimulators](http://www.nfrccommunity.org/page/CertifiedSimulators)
  - .4 Generic thermal simulation charts that are not based on the specified glass will Not be accepted.
  - .3 Provide component dimensions, describe components within assembly, anchorage and fasteners, glass and infill, internal drainage details and water flow diagrams.
- 1.8 Shop Drawings
- .1 Submit shop drawings in accordance with Section 01 33 00 - Submittal Procedures.
  - .2 Indicate system dimensions, framed opening requirements and tolerances, adjacent construction, anticipated deflection under load, affected related Work, weep drainage network, expansion and contraction joint location and details, and field welding required.
  - .3 **Shop drawings shall bear the stamp of a Registered Professional Engineer licensed to practice in Ontario.**
- 1.9 Design Data
- .1 Submit design data in accordance with Section 01 33 00 - Submittal Procedures.
- 1.10 Pre-installation Meeting
- .1 Convene one week before starting work of this Section.
- 1.11 Delivery, Storage, and Handling
- .1 Deliver, store, handle and protect materials in accordance with Section 01 61 00 -. Basic Product Requirements.
  - .2 Handle work of this section in accordance with AAMA CW-10.
  - .3 Protect prefinished aluminum surfaces with wrapping. Do not use adhesive papers or sprayed coatings which bond when exposed to sunlight or weather.
- 1.12 Environmental Requirements
- .1 Do not install sealants when ambient and surface temperature is less than 5°C.
  - .2 Maintain this minimum temperature during and after installation of sealants.
- 1.13 Sequencing
- .1 Coordinate work of this section with installation of air barrier placement, vapour retarder placement, flashing placement.
- 1.14 Warranty
- .1 Provide a written warranty, signed and issued in the name of the Owner and the Project, stating that the Contractor, Sub-Contractor and/or manufacturer jointly and severally warrant the complete aluminum frame system against leakage, in accordance with GC 12.3 as amended by the Supplementary General Conditions, but for a period of five (5) years.

---

**PART 2 - PRODUCTS**

## 2.1 Materials

- .1 Extruded aluminum: AA6063-T6 alloy.
- .2 Sheet aluminum: AA alloy 5005-HSX.
- .3 Fasteners: stainless steel.
- .4 Bituminous paint: CAN/CGSB 1.108, Type 1, without thinner.
- .5 Vertical Glass Units:
  - .1 Glass in exterior lights: Insulated tempered glass units.
  - .2 Glass in entrance lights: Insulated tempered glass units.
  - .3 Refer to Section 08 80 50.
- .6 Sealant: to Section 07 92 10.

## 2.2 Components

- .1 Mullion profiles: thermally broken with interior tubular section insulated from exterior pressure plate; matching stops and pressure plate of sufficient size and strength to provide adequate bite on glass and infill panels; drainage holes, deflector plates and internal flashings to accommodate internal weep drainage system; internal mullion baffles to eliminate "stack effect" air movement within internal spaces. Refer to Drawings for profile sizes, shapes and locations.
- .2 Mullion caps: provide standard mullion caps as indicated on Drawings and as indicated below.
  - .1 Standard mullion cap: 19.1mm standard cap.
- .3 Infill panel: internally reinforced, glazing edge sealed permitting internal air movement to glazing space, outside air barrier line:
  - .1 Outer face: insulated spandrel glass unit; refer to Section 08 80 50.
  - .2 Core: rigid polystyrene insulation core with maximum RSI to maintain 6mm maximum gap between glass unit and insulation.
  - .3 Inner liner panels: 3.18mm thick galvanized steel.
- .4 Fabricate spandrel panels for 'glazed in' installation.
- .5 Operable units: specified in Section 08 50 50 - Aluminum Windows
- .6 Column covers: 3.18mm thick aluminum, full contact pressure bonded to, ensuring flat surface, finish to match curtain wall mullion sections, secured with concealed fastening method.
- .7 Flashings: 3.18mm thick architectural aluminum, finish to match curtain wall mullion sections where exposed, brake-formed to shapes indicated; secured with concealed fastening method.
- .8 Thermal Break: extruded rigid PVC.
- .9 Gaskets: extruded EPDM.
- .10 Sealant backing rod: Extruded foam closed cell, round polyethylene rod, 25% wider than joint width, "H.B.R." backer rod, or non-gassing "SOF Rod" by Tremco.
- .11 Air barrier: specified in Section 07 27 10 - Air Barriers.

## 2.3 Fabrication

- .1 Fabricate system components with minimum clearances and shim spacing around perimeter of assembly yet enabling installation and dynamic movement of perimeter seal.
- .2 Accurately fit and secure joints and corners. Make joints flush, hairline, and weatherproof.
- .3 Prepare components to receive anchor devices. Install anchors.
- .4 Arrange fasteners and attachments to ensure concealment from view.
- .5 Prepare system components to receive exterior doors, specified in Section 08 11 16.
- .6 Reinforce framing members for external imposed loads.
- .7 Visible manufacturer's identification labels not permitted.

**2.4 Fabrication: Infill Panels**

- .1 Fabricate infill panels with metal covered edge seals around perimeter of panel assembly, enabling installation and minor movement of perimeter seal.
- .2 Reinforce interior surface of exterior panel sheet from deflection caused by wind and suction loads.
- .3 Accurately fit and secure joints and corners. Make joints flush, hairline, and weatherproof.
- .4 Place insulation within panel, adhered to exterior face of interior panel sheet over entire area of sheet with impale fasteners.
- .5 Ventilate and pressure equalize the air space outside the exterior surface of the insulation, to the exterior.
- .6 Arrange fasteners and attachment to ensure concealment from view.

**2.5 Finishes**

- .1 Finish exposed surfaces of aluminum components in accordance with Aluminum Association Designation System for Aluminum Finishes.
  - .1 Clear Anodic Finish: designation AA-A41 Class 1, 0.018mm minimum thickness.
- .2 Appearance and properties of anodized finishes designated by the Aluminum Association as Architectural Class 1, Architectural Class 2, and Protective and Decorative shall meet requirements of CGSB 63-GP-2M+Amdt-Jul-8 0, for coating Classes 1, 2 and 3 respectively.
- .3 Apply two coats of bituminous paint to concealed aluminum and steel surfaces in contact with cementitious or dissimilar materials.

**2.6 Source Quality Control**

- .1 Perform work in accordance with AAMA GSM-1 AAMA CW-I-9.
- .2 Installer qualifications: company specializing in performing the work of this section approved by manufacturer.
- .3 Design structural support framing components to CAN/CSA-S157 under direct supervision of a Professional Structural Engineer experienced in design of this Work and licensed in the Province of Ontario.
- .4 Perform welding Work in accordance with CSA W59.2.

**PART 3 - EXECUTION****3.1 Examination**

- .1 Verify dimensions, tolerances, and method of attachment with other work.
- .2 Verify wall openings and adjoining air barrier and vapour retarder materials are ready to receive work of this section.

**3.2 Installation**

- .1 Install curtain wall system in accordance with manufacturer's instructions.
- .2 Attach to structure to permit sufficient adjustment to accommodate construction tolerances and other irregularities.
- .3 Provide alignment attachments and shims to permanently fasten system to building structure. Clean weld surfaces; apply protective primer to field welds and adjacent surfaces.
- .4 Align assembly plumb and level, free of warp or twist. Maintain assembly dimensional tolerances and align with adjacent work.
- .5 Provide thermal isolation where components penetrate or disrupt building insulation.
- .6 Install sill flashings.

- .7 Pack fibrous insulation in shim spaces at perimeter of assembly to maintain continuity of thermal barrier.
- .8 Install glass and infill panels in accordance with Section 08 80 50 - Glazing, to glazing method required to achieve performance criteria.
- .9 Mechanically secure from rear before assembly, reveal edged 12.7mm gypsum board panels supplied by Section 09 21 16 for curtain walls as indicated on Drawings.
- .10 Install perimeter sealant to method required to achieve performance criteria. Type, backing materials, and installation criteria in accordance with Section 07 92 10 - Joint Sealing.

### 3.3 Site Tolerances

- .1 Maximum variation from plumb: 1.5mm/ metre non-cumulative or 12mm/ 30metre, whichever is less.
- .2 Maximum misalignment of two adjoining members abutting in plane: 0.8mm.
- .3 Maximum sealant space between curtain wall and adjacent construction: 13mm.

### 3.4 Manufacturer's Field Services

- .1 Curtain wall product manufacturers to provide field surveillance of the installation of their Products.
- .2 Monitor and report installation procedures, unacceptable conditions and conflicts.

### 3.5 Cleaning

- .1 Remove protective material from prefinished aluminum surfaces.
- .2 Wash down surfaces with a solution of mild detergent in warm water, applied with soft, clean wiping cloths. Take care to remove dirt from corners. Wipe surfaces clean.
- .3 Remove excess sealant by moderate use of mineral spirits or other solvent acceptable to sealant manufacturer.

### 3.6 Protection

- .1 Protect finished Work from damage.

END OF SECTION

## **PART 1 - GENERAL**

### 1.1 General

- .1 Conform to Division 01 - General Requirements.

### 1.2 Related Sections

- .1 Section 07 92 10 – Joint Sealing.
- .2 Section 08 44 13 – Glazed Aluminum Curtain Walls.
- .3 Section 08 80 50 – Glazing.

### 1.3 References

- .1 Canadian General Standards Board (CGSB)
  - .1 CAN/CGSB-1.40-97, Primer, Structural Steel, Oil Alkyd Type.
  - .2 CAN/CGSB-79.1-M91, Insect Screens.
- .2 Canadian Standards Association (CSA)
  - .1 CAN/CSA-A440-00 (R2005), Windows.
- .3 North American Fenestration Standard (NAFS-11).

### 1.4 Approved Manufacturers

- .1 To establish a standard for bidding purposes, the Drawings are based upon Alumicor Limited: Univent 1350 Series projected vents/ hoppers are approved.
- .2 The following manufacturers are approved, subject to total compliance with this Specification:
  - .1 Kawneer Company of Canada Limited.
  - .2 Sherwood Windows Group.
  - .3 Aerloc Industries Ltd.

### 1.5 Work Included

- .1 Supply and install all factory assembled and prefinished extruded aluminum windows complete with glass and glazing, operable hardware, weatherstripping, screens and all required anchorages, attachments and shims and perimeter weather seals.

### 1.6 Shop Drawings

- .1 Submit shop drawings in accordance with Section 01 33 00 - Submittal Procedures.
- .2 Indicate materials and details in scale full size for head, jamb and sill, profiles of components, interior and exterior trim junction between combination units elevations of unit, anchorage details, location of isolation coating, description of related components and exposed finishes fasteners, and caulking. Indicate location of manufacturer's nameplates.

### 1.7 Samples

- .1 Submit samples in accordance with Section 01 33 00 - Submittal Procedures.
- .2 Submit a corner cross section of window, showing sill and jamb section, complete with hardware, weatherstripping, glass, screening, etc. and other items to be used at the windows, including finish(es) of aluminum.

---

## 1.8 Test Reports

- .1 Submit test reports from approved independent testing laboratories, certifying compliance with specifications, for:
  - .1 Windows classification to CAN/CSA-A440/ NAFS-11-AW.
  - .2 Anodized finish.
  - .3 Insect screens.
  - .4 Air tightness.
  - .5 Water tightness.
  - .6 Wind load resistance.
  - .7 Condensation resistance.
  - .8 Ease of operation - windows with operable lights.
  - .9 Forced entry resistance.
  - .10 Mullion deflection - combination and composite windows.

## 1.9 Maintenance Data

- .1 Provide operation and maintenance data for windows for incorporation into manual specified in Section 01 78 00 - Closeout Submittals.
- .2 Arrange with and demonstrate to building maintenance staff window operation, cleaning, reglazing and general maintenance procedures.

## 1.10 Warranty

- .1 Provide a written warranty, signed and issued in the name of the Owner and Project stating that the contractor, Sub-contractor and/or manufacturer jointly and severally warrant the complete aluminum window system against leakage, defects and malfunction under normal usage in accordance with GC 12.3 as amended by the Supplementary General Conditions, but for a period of:
  - .1 Two years for parts and labour on all components;
  - .2 Three years for caulking against cracking, crumbling, melting, shrinking, running, lose adhesion or stain adjacent surfaces;
  - .3 Five years for the insulating glass units against failure of seal of enclosed air space and deposits on inner faces of glass detrimental to vision;
  - .4 all from the date of Substantial Performance of the Work.

## **PART 2 - PRODUCTS**

### 2.1 Materials

- .1 Sash, frame and screen member: Extruded aluminum alloy 6063-T6, minimum 1.6mm thick.
- .2 Aluminum operable windows to be compliant with the performance requirements of CAN/CSA-A440 Classification A3, B7, C5 and I=63.
- .3 Exterior/ interior panning: Extruded aluminum alloy 6063-T5, minimum 1.6mm thick.
- .4 Thermal break: Extruded virgin polyvinyl chloride thermo-barrier.
- .5 Weatherstripping: Fin-Seal polypropylene woven pile seal.
- .6 Insect screens: To CAN3-A440-M90, heavy duty, 18 x 14 fiberglass mesh.
- .7 Fasteners: Non-magnetic, stain and corrosion resistant stainless steel to ASTM E-149.
- .8 Exposed surfaces of aluminum components in accordance with Aluminum Association A-A41 Class I, 0.018mm minimum thickness; CLEAR ANODIZED.
- .9 Thermal Insulation:
  - .1 Loose Insulation: glass fibre, density of 12kg/ m<sup>3</sup>, by Fibreglas Canada.
  - .2 Foam Insulation: One or two-part, polyurethane, similar to products produced by BASF Canada Inc.

---

## 2.2 Glazing

- .1 Refer to Section 08 80 50 - Glazing.
- .2 Glazing materials: wrap around polyvinyl chloride glazing channel.
- .3 Bedding compound: to CGS 19-GP-14M.
- .4 Sealants: to Section 07 92 10, colour to match frames.
- .5 Isolation coating: Alkali resistant bituminous paint.

## 2.3 Fabrication

- .1 Operable windows: Fabricate windows using two separate frames joined by means of a thermal break and as follows:
  - .1 Cope and butt joints in main frame and sash neatly in weather tight manner and secure by means of screws anchored into integral screw ports.
  - .2 Secure sash corners with thread-cutting type screw to ensure tight corners when re-assembling after glass repairs have been made.
  - .3 Internally seal all sash corners.
  - .4 Deburr and make smooth all sharp milled edges and corners of frames.
  - .5 Provide tubular sections for all vertical sash rails, screen frame and sill frame.
  - .6 Provide outside main frame sill with device of exterior sash.
  - .7 Provide sill members with minimum 5° slope.
  - .8 Provide sill weep system which will facilitate drainage of water accumulating in the sill area while preventing passage of air, dirt and insects from exterior to the interior.
  - .9 Fabricate and anchor both inner and outer frames using specified screw fasteners without violating the thermal break.
  - .10 Exposed fasteners or the use of pop rivets is not acceptable.
  - .11 Fabricate entire window in a manner that will allow easy replacement of any defective, damaged, worn components, hardware or weatherstripping.
  - .12 Completely separate all operating surfaces from metal to metal contact.
  - .13 Hardware for operable windows:
    - .1 Hinges: Equip each operable window with one pair stainless steel, four bar friction arm hinges complete with semi-concealed device to adjust operating tension.
    - .2 Locks: Equip each operable unit with two locking claw handles.
  - .14 Provide multiple weatherstripping in perimeters.
- .2 Thermo-Barrier:
  - .1 Provide complete metal to metal separation between the two main frame members.
  - .2 Do not use connecting screws, clips or other devices which would tend to bridge the two frame members or restrict in any manner the expansion and contraction of the individual separate frame members.
  - .3 Factory seal between thermo barrier and frame around perimeter to ensure weather tight assembly.
- .3 Glazing:
  - .1 Provide sash frames which will permit glass replacement without the use of special tools.
- .4 Weatherstripping:
  - .1 Double weatherstrip window units at all sash perimeters
  - .2 Conceal weatherstripping to prevent accumulation of foreign matter due to cleaning, operation or handling which would affect the effective life of the seal.
  - .3 Install all weatherstripping in specially extruded ports and secure to prevent shrinkage, movement or loss when removing sash for cleaning or glass replacement.
- .5 Exterior sills:
  - .1 Provide one piece extruded aluminum sections of type and size to suit job conditions, complete with joint covers, jamb drip deflectors, chairs and anchoring devices.

- .2 Jamb deflectors to be anchored with concealed fastener.
- .3 Join sill sections at corners utilizing integral screw ports and screws and back seal.
- .6 Screens:
  - .1 Factory install in tubular extruded aluminum frames and secure in place using vinyl spline.
  - .2 Screen is to be located on interior side of awning type window.
  - .3 Screen guide channels or fins which facilitate the operation of the screen shall be an integral part of the window frame or thermo-barrier.
  - .4 Channels or fins which are surface applied to window frame or thermo-barrier by means of screws or rivets are not acceptable.

#### 2.4 Isolation Coating

- .1 Isolate aluminum from following components, by means of isolation coating:
  - .1 Dissimilar metals except stainless steel, zinc, or white bronze of small area.
  - .2 Concrete, mortar and masonry.
  - .3 Wood.

#### 2.5 Air Barrier and Vapour Retarder

- .1 Equip window frames with site installed air barrier and vapour retarder material for sealing to building air barrier and vapour retarder as follows:
  - .1 Material: identical to, or compatible with, building air barrier and vapour retarder materials to provide required air tightness and vapour diffusion control throughout exterior envelope assembly.
  - .2 Material width: adequate to provide required air tightness and vapour diffusion control to building air barrier and vapour retarder from interior.

### **PART 3 - EXECUTION**

#### 3.1 Preparation

- .1 Protect adjacent surfaces from damage resulting from work under this Specification.

#### 3.2 Installation

- .1 Install in accordance with CAN/CSA-A440 and manufacturer's instructions.
- .2 Arrange components to prevent abrupt variation in colour.
- .3 Erect and secure window units plumb, square and level relative to building structure and free from warp, twist or superimposed loads. Do not exceed 3mm in 3050mm variation from plumb and level.
- .4 Pack loose fill insulation into void between exterior aluminum frame and window opening.
- .5 Seal joints between frame and members and perimeter window openings with sealants to provide weather tight seal outside and air/vapour seal inside.
- .6 Maintain integrity of vapour retarder and air barrier system within systems installed by this Section and between systems and adjoining construction.
- .7 Use concealed fastenings as recommended by manufacturer. Exposed screws, bolts or nut heads are not permitted.
- .8 Secure work adequately and accurately to the structure in the required position, in a manner not restricting thermal and wind movement for windows. Lock all adjacent settings after their alignment.

### 3.3 Sill Installation

- .1 Install aluminum sills with uniform wash to exterior, level in length, straight in alignment with plumb upstands and faces. Use one piece at each location.
- .2 Cut sills to fit window opening and round exterior corners.
- .3 Secure sills in place with anchoring devices located at end joints of continuous sills and evenly spaced 600mm o.c. in between.
- .4 Fasten expansion joint cover plates and drip deflectors with self tapping stainless steel screws.
- .5 Maintain 6 to 9mm space between butt ends of continuous sills. For sills over 1200mm in length, maintain 3 to 6mm space at each end.

### 3.4 Caulking

- .1 Supply and install sealant at perimeters of aluminum windows between frames and interior/exterior building components to Section 07 92 10.
- .2 Caulk joints between frame members and other non-operating components to provide weather tight seal at outside and air/vapour seal at inside.
- .3 Seal joints between windows and window sills with sealant. Bed sill expansion joint cover plates and drip deflectors in bedding compound. Caulk between sill upstand and window-frame. Caulk butt joints in continuous sills
- .4 Apply sealant in accordance with Section 07 92 10 - Joint Sealing. Conceal sealant within aluminum work except where exposed use is permitted by Consultant.
- .5 Caulk joints between mullions, frames, rails and sills as required for weatherproof installation.
- .6 Provide aluminum panning if caulk joint is larger than 12mm.

### 3.5 Clean Up

- .1 Upon completion, provide final cleaning of glass and frames.
- .2 Leave surfaces clean, free from labels, sealants and dirt.

END OF SECTION

---

**PART 1 - GENERAL**

- 1.1 General
  - .1 Conform to Division 01 - General Requirements.
- 1.2 Work Included in This Section
  - .1 Supply & installation of finishing hardware by Allowance; reference Section 01 21 00.
- 1.3 Coordination
  - .1 Coordinate the hardware with other allied trades such as carpentry, millwork, aluminium door and screens, hollow metal doors and frames, electrical and others.
- 1.4 Handling and Storage
  - .1 Handle and store materials on job site in such a manner that no damage will be done to the materials.
  - .2 Deliver and store materials undamaged in a dry area.
  - .3 Wrap all hardware in separate packages complete with all trimming and screws required for each item, distinctly labelled and numbered for each opening to correspond with the final reviewed Finish Hardware Schedule.
- 1.5 Hardware Reinforcement
  - .1 Reference *Door and Frame Schedule* for typical hardware to be used on this project. Provision of hardware reinforcing required providing a firm support for hardware is under other sections of these specifications. Report any doors, frames or panels which have not been adequately reinforced.
- 1.6 Fire and Building Codes
  - .1 All hardware shall comply with applicable fire and building codes and requirements of local authority having jurisdiction over hardware. All electrical items must have CSA approval.
- 1.7 Barrier Free Requirements
  - .1 The building is designed to meet the needs of barrier free access. All hardware shall be supplied and installed in accordance with the Ontario Building Code (OBC).
- 1.8 Submittals
  - .1 Shop Drawings
    - .1 Prepare and submit to the Consultant for review, 1 electronic copy of the hardware schedule & 1 electronic copy of the electrical elevation coordination drawings showing all hardware required for each opening.
  - .2 For Maintenance Use: Submit the following to the Consultant:
    - .1 One set wrenches for locksets, exit devices and door closers.
    - .2 Three sets of manufacturer's installation instructions for locksets.
    - .3 Three sets of manufacturer's instructions in regard to proper care of hardware including lubrication of locksets, exit devices and door closers.
    - .4 One complete set of template schedules.
    - .5 Catalogue cuts of all hardware installed.

1.9 Warranty

- .1 Submit a warranty in accordance with Section 01 78 00, covering the repair or replacement of defective work within specified periods.
- .2 Provide total warranty of 5 years for locksets and exit devices, 10 years for door closers, and 2 years for other hardware. Hinges require a written warranty from the manufacturer for the lifetime of the hinges.
- .3 State in the warranty that any defective (material and operation) item of hardware shall be replaced immediately upon notification that item is defective.

**PART 2 - PRODUCTS**

2.1 Hardware by Cash Allowance – Reference Section 01 21 00.

- .1 The approved finishing hardware schedule will govern final door and frame preparations.

2.2 Keying

- .1 Review and establish keying system with Owner.

2.3 Templates

- .1 All hardware applied to metal doors and frames shall be made to template. Furnish templates, together with instructions necessary for door and frame preparation.

2.4 Fasteners

- .1 Provide screws, rivets, bolts, expansion shields, and other fastening devices as required for the satisfactory installation and operation of the hardware. Provide Robertson or Phillips heads.
- .2 Fastening devices shall be of the same finish as the hardware which is to be fastened.
- .3 Where a pull is scheduled on one side of the door and a push plate on the other side, issue installation directions to the trade responsible for fixing, so that the pull is secured through the door from the reverse side, and the push plate installed to cover the screws. Supply flush pulls with machine screws for attaching as specified above.
- .4 For fastenings in concrete for floor stops and thresholds, use machine screws in expansion shields.

**PART 3 - EXECUTION**

3.1 Installation

- .1 As specified in Section 01 21 00 – supply and installation of finishing hardware is by Cash Allowance.

END OF SECTION

---

**PART 1 - GENERAL**

1.1 General

- .1 Conform to Division 01 - General Requirements.

1.2 Related Sections

- .1 Section 08 11 14 – Metal Doors and Frames.
- .2 Section 08 11 16 – Aluminum Doors and Frames.
- .3 Section 08 41 13 – Glazed Aluminum Curtain Walls.
- .4 Section 08 50 50 – Aluminum Windows.

1.3 References

- .1 American Society for Testing and Materials (ASTM)
  - .1 ASTM C542 – 05(2017), Specification for Lock-Strip Gaskets.
  - .2 ASTM E330-02, Test Method for Structural Performance of Exterior Windows, Curtain Walls and Doors by Uniform Static Air Pressure Difference.
- .2 Canadian Door and Window Manufacturers, Certification Program.
- .3 Canadian General Standards Board (CGSB)
  - .1 CAN/CGSB-12.1-2017, Tempered or Laminated Safety Glass.
  - .2 CAN/CGSB-12.2-M91 (R2017), Flat, Clear Sheet Glass.
  - .3 CAN/CGSB-12.3-M91 (R2017), Flat, Clear Float Glass.
  - .4 CAN/CGSB-12.4-M91 (R2017), Heat Absorbing Glass.
  - .5 CAN/CGSB-12.5-M86, Mirrors, Silvered.
  - .6 CAN/CGSB-12.8-2017, Insulating Glass Units.
  - .7 CAN/CGSB-12.9-M91, Spandrel Glass.
  - .8 CAN/CGSB-12.10-M76, Glass, Light and Heat Reflecting.
- .4 Canadian Standards Association (CSA)
  - .1 CSA A440.2-14, Energy Performance Evaluation of Windows and Sliding Glass Doors.
- .5 North American Fenestration Standard (NAFS-11).
- .6 Flat Glass Manufacturers Association (FGMA), Glazing Manual
- .7 Laminators Safety Glass Association, Standards Manual.

1.4 Performance Requirements

- .1 Provide continuity of building enclosure vapour and air barrier using glass and glazing materials as follows:
  - .1 Utilize inner light of multiple light sealed units for continuity of air and vapour seal.
- .2 Size glass to withstand wind loads, dead loads and positive and negative live loads as measured in accordance with ANSI/ASTM E 330.

1.5 Shop Drawings

- .1 Submit shop drawings in accordance with Section 01 33 00 - Submittal Procedures.

1.6 Samples

- .1 Submit samples in accordance with Section 01 33 00 - Submittal Procedures.
- .2 Submit duplicate 300mm x 300mm size samples of glass types.

1.7 Closeout Submittals

- .1 Provide maintenance data including cleaning instructions for incorporation into manual specified in Section 01 78 00 – Closeout Submittals.

1.8 Quality Assurance

- .1 Perform work in accordance with FGMA Glazing Manual IGMAC and Laminators Safety Glass Association - Standards Manual for glazing installation methods.

1.9 Environmental Requirements

- .1 Install glazing when ambient temperature is 10°C minimum. Maintain ventilated environment for 24 hours after application.
- .2 Maintain minimum ambient temperature before, during and 24 hours after installation of glazing compounds.

**PART 2 - PRODUCTS**

2.1 Materials: Flat Glass

- .1 Safety glass: to CAN/CGSB-12.1, transparent, 6mm thick.
  - .1 Type 2-tempered.
  - .2 Class B-float.
- .2 Fire rated glass: to CAN/ULC-S-104, laminated fire rated polished and impact safety rated glazing, 8mm thick.
  - .1 Approved materials:
    - .1 Pyran Platinum L as manufactures by Schott North America Inc.
    - .2 FireLite Plus as manufactured by Technical Glass Products.

2.2 Materials: Sealed Insulating Glass

- .1 Insulating glass units: to CAN/CGSB-12.8, double unit.
  - .1 Glass: to CAN/CGSB-12.1; safety glass.
  - .2 Glass thickness: 6mm each light.
  - .3 Inter-cavity space thickness: 12.5mm between lights w/ low conductivity spacer.
  - .4 Glass coating: surface number 3, low "E".
    - .1 Acceptable material: Solarban 60 as manufactured by PPG Industries, or alternate, providing minimum Winter U value of 0.29, solar heat gain coefficient of 0.39, and visible light transmittance of 70%.
  - .5 Cavity: Argon filled.
  - .6 Colour:
    - .1 Exterior Pane: MATCH EXISTING (SOLAR GREY).
    - .2 Interior Pane: CLEAR.
- .2 Opaque insulating glass units (Spandrel): to CAN2-12.9M; double unit.
  - .1 Glass: to CAN/CGSB-12.1; safety glass.
  - .2 Glass thickness: 6mm each light.
  - .3 Inter-cavity space thickness: 12.5mm between lights w/ low conductivity spacer.
  - .4 Glass coating: surface number 4.
    - .1 Acceptable material: Opaci-coat 300 by ICD High Performance Coatings, custom colours (refer to Drawings for number of colours to be provided).
  - .5 Cavity: Argon filled.
  - .6 Colour:
    - .1 Exterior Pane: CLEAR.
    - .2 Interior Pane: CLEAR.

---

## 2.3 Materials

- .1 Sealant: to glass manufacturers standard.
  - .1 Acceptable material: ECP-45.

## 2.4 Accessories

- .1 Setting blocks: Neoprene, 80-90 Shore A durometer hardness to ASTM D2240, to suit glazing method, glass light weight and area.
- .2 Spacer shims: Neoprene, 50-60 Shore A durometer hardness to ASTM D2240, 75mm long x one half height of glazing stop x thickness to suit application. Self adhesive on one face.
- .3 Glazing tape: Preformed butyl, 10-15 Shore A durometer hardness to ASTM D2240; coiled on release paper; 3 x 13mm size; black colour.
- .4 Lock-strip gaskets: to ASTM C542.

## **PART 3 - EXECUTION**

### 3.1 Examination

- .1 Verify that openings for glazing are correctly sized and within tolerance.
- .2 Verify that surfaces of glazing channels or recesses are clean, free of obstructions, and ready to receive glazing.

### 3.2 Preparation

- .1 Clean contact surfaces with solvent and wipe dry.
- .2 Seal porous glazing channels or recesses with substrate compatible primer or sealer.
- .3 Prime surfaces scheduled to receive sealant.

### 3.3 Installation: Exterior - Dry Method (Preformed Glazing)

- .1 Cut glazing tape to length; install on glazing light. Seal corners by butting tape and sealing junctions with sealant.
- .2 Place setting blocks at 1/4 points, with edge block maximum 150mm from corners.
- .3 Rest glazing on setting blocks and push against fixed stop with sufficient pressure to attain full contact.
- .4 Install removable stops without displacing glazing tape spline. Exert pressure for full continuous contact.
- .5 Trim protruding tape edge.

### 3.4 Installation: Exterior Wet/Dry Method (Preformed Tape and Sealant)

- .1 Cut glazing tape to length and set against permanent stops, 6mm below sight line. Seal corners by butting tape and dabbing with sealant.
- .2 Apply heel bead of sealant along intersection of permanent stop with frame ensuring full perimeter seal between glass and frame to complete continuity of air and vapour seal.
- .3 Place setting blocks at 1/4 points, with edge block maximum 150mm from corners.
- .4 Rest glazing on setting blocks and push against tape and heel head of sealant with sufficient pressure to attain full contact at perimeter of light or glass unit.
- .5 Install removable stops with spacer strips inserted between glazing and applied stops 6mm below sight line. Place glazing tape on glazing light or unit with tape flush with 16mm below sight line.
- .6 Fill gap between glazing and stop with sealant to depth equal to bite of frame on glazing, maximum 9mm below sight line.

- .7 Apply cap head of sealant along void between stop and glazing, to uniform line, flush with sight line. Tool or wipe sealant surface smooth.

### 3.5 Installation: Interior - Dry Method (Tape and Tape)

- .1 Cut glazing tape to length and set against permanent stops, projecting 1.6mm above sight line.
- .2 Place setting blocks at 1/4 points, with edge block maximum 150mm from corners.
- .3 Rest glazing on setting blocks and push against tape for full contact at perimeter of light or unit.
- .4 Place glazing tape on free perimeter of glazing in same manner described.
- .5 Install removable stop without displacement of tape. Exert pressure on tape for full continuous contact.
- .6 Knife trim protruding tape.

### 3.6 Protection

- .1 Provide safety markings to installed glass by attaching streamers or tape to face of sash. Do not apply tape directly to glass. Do not mark the glass with paint or any other substance that is hard to remove or could leave permanent stains.
- .2 Take all precautions necessary to protect stored glass and installed glass from lime mortar, water run-off from concrete or copper, weld splatter, acids, roofing tar, solvents, abrasive cleaners, careless handling of construction machinery and equipment, and any other activities that could permanently damage the glass.
- .3 Install protective cover to glass where there is a high risk of damage. Use plywood, heavy kraft paper, or non-staining transparent plastic sheet. Do NOT let protective materials contact surface of glass.
- .4 Do not rely on use of adhesive plastic films to protect installed glass. When plastic is sheeting is used, it must be transparent, suspended away from the surface of the glass, and be provided with adequate ventilation holes to prevent heat build-up.

### 3.7 Cleaning

- .1 Remove glazing materials from finish surfaces.
- .2 Remove labels after work is complete.
- .3 Clean all glass and mirrors.
- .4 Remove and replace glass that is broken, chipped, cracked, abraded or damaged in other ways during construction period, including natural causes, accidents and vandalism.

END OF SECTION

---

**PART 1 - GENERAL**

1.1 General

- .1 Conform to Division 01 – General Requirements.

1.2 Related Sections

- .1 Section 07 92 10 – Joint Sealing.
- .2 Section 09 22 16 – Non-Structural Metal Framing.
- .3 Section 09 22 27 – Acoustical Suspension.
- .4 Section 09 91 10 – Painting.
- .5 Mechanical – refer to Mechanical Drawings.
- .6 Electrical – refer to Electrical Drawings.

1.3 References

- .1 Aluminum Association
  - .1 Designation for Aluminum Finishes.
- .2 American Society for Testing and Materials (ASTM)
  - .1 ASTM C36, Specification for Gypsum Wallboard.
  - .2 ASTM C79, Specification for Gypsum Sheathing Board.
  - .3 ASTM C442, Specification for Gypsum Backing Board and Coreboard.
  - .4 ASTM C475, Specification for Joint Compound and Joint Tape for Finishing Gypsum Board.
  - .5 ASTM C514, Specification for Nails for the Application of Gypsum Board.
  - .6 ASTM C557, Specification for Adhesives for Fastening Gypsum Wallboard to Wood Framing.
  - .7 ASTM C630, Specification for Water-Resistant Gypsum Backing Board.
  - .8 ASTM C840, Specification for Application and Finishing of Gypsum Board.
  - .9 ASTM C931/931, Specification for Exterior Gypsum Soffit Board.
  - .10 ASTM C954, Specification for Steel Drill Screws for the Application of Gypsum Board.
  - .11 ASTM C960, Specification for Predecorated Gypsum Board.
  - .12 ASTM C1002, Specification for Steel Drill Screws for the Application of Gypsum Board or Metal Plaster Bases.
  - .13 ASTM C1047, Specification for Accessories for Gypsum Wallboard and Gypsum Veneer Base.
  - .14 ASTM C1280, Specification for Application of Gypsum Sheathing Board.
  - .15 ASTM C1177, Specification for Glass Mat Gypsum Substrate for Use as Sheathing.
  - .16 ASTM C1178, Specification for Glass Mat Water-Resistant Gypsum Backing Board.
- .3 Canadian General Standards Board (CGSB)
  - .1 CAN/CGSB-51.34-M, Vapour Barrier, Polyethylene Sheet for Use in Building Construction.
  - .2 CAN/CGSB-71.25-M, Adhesive, for Bonding Drywall to Wood Framing and Metal Studs.
- .4 Underwriters Laboratories of Canada (ULC)
  - .1 CAN/ULC-S102, Building Materials and Assemblies, Standard Method of Test for Surface Burning Characteristics of Building Materials and Assemblies.
- .5 Gypsum Association (GA)
  - .1 GA-216, Application and Finishing of Gypsum Board.
  - .2 GA-600, Fire Resistance Design Manual.

---

1.4 Samples

- .1 Submit samples in accordance with Section 01 33 00 - Submittal Procedures.
- .2 Submit 300mm long samples of corner and casing beads and reveals.

1.5 Site Environmental Requirements

- .1 Maintain temperature minimum 15°C, maximum 21°C for 48 hours prior to and during application of gypsum boards and joint treatment, and for at least 48 hours after completion of joint treatment.
- .2 Apply board and joint treatment to dry, frost free surfaces.

1.6 Quality Assurance

- .1 Subcontractor executing the Work of this Section shall have adequate plant, equipment and skilled tradesmen to provide installations of work of this type and quality indicated and specified.
- .2 Single source responsibility: Obtain gypsum board products from single manufacturer, or from manufacturers recommended by prime manufacturer of gypsum boards.
- .3 Fire resistance rating: Where gypsum board systems with fire resistance ratings are indicated or required, provide materials and installations that are identical with those of applicable assemblies tested by fire testing laboratories acceptable to authorities having jurisdiction.

**PART 2 - PRODUCTS**

2.1 Materials

- .1 Fire resistant board (GB): Type X to ULC Guide No. 40 U18.23, thickness as noted on drawings, 1220mm wide x maximum practical length, ends square cut, edges tapered, glass mat faced, water resistant treated core.
- .2 Glass mat wall board (GB): to ASTM C1177 regular, 15.9mm thick, 1220mm wide x maximum practical length, ends square cut, edges tapered, glass mat faced, water resistant treated core.
- .3 Impact resistant glass mat wall board (GB): to ASTM C1177 regular, 15.9mm thick, 1220mm wide x maximum practical length, ends square cut, edges tapered, glass mat faced, water resistant treated core.
- .4 Tile-backer board: to ASTM C1178; thicknesses as indicated on Drawings x maximum practical length.
- .5 Metal furring runners, hangers, tie wires, inserts, anchors: to ASTM C841.
- .6 Drywall furring channels: 0.5mm core thickness galvanized steel channels for screw attachment of gypsum board.
- .7 Resilient clips drywall furring: 0.5mm base steel thickness galvanized steel for resilient attachment of gypsum board.
- .8 Steel drill screws: to ASTM C1002.
- .9 Stud adhesive: to CAN/CGSB-71.25 ASTM C557.
- .10 Laminating compound: as recommended by manufacturer, asbestos-free.
- .11 Casing beads, corner beads, control joints and edge trim: to ASTM C1047, Zinc metal, zinc-coated by electrolytic process, 0.5mm base thickness, perforated flanges, one piece length per location.
- .12 Reveal joints: rigid PVC, sizes as indicated on Drawings.
  - .1 Acceptable manufacturer:
    - .1 Trintex, or approved alternate.
- .13 Sealants: in accordance with Section 07 92 10 - Joint Sealers.
- .14 Acoustic sealant: Refer to Section 07 92 10.
- .15 Polyethylene: to CAN/CGSB-51.34, Type 2.

- .16 Insulating strip: rubberized, moisture resistant, 3mm thick closed cell neoprene strip, 12mm wide, with self sticking permanent adhesive on one face, lengths as required.
- .17 Joint reinforcement tape: 50mm wide, glass fibre mesh.
- .18 Joint compound: to ASTM C475, asbestos-free.

### **PART 3 - EXECUTION**

#### 3.1 Erection

- .1 Do application and finishing of gypsum board in accordance with ASTM C840 except where specified otherwise.
- .2 Erect hangers and runner channels for suspended gypsum board ceilings in accordance with ASTM C840 except where specified otherwise.
- .3 Support light fixtures by providing additional ceiling suspension hangers within 150mm of each corner and at maximum 600mm around perimeter of fixture.
- .4 Install work level to tolerance of 1:1200.
- .5 Frame with furring channels, perimeter of openings for access panels, light fixtures, diffusers, grilles, etc.
- .6 Install furring channels parallel to, and at exact locations of steel stud partition header track.
- .7 Furr for gypsum board faced vertical bulkheads within and at termination of ceilings.
- .8 Furr above suspended ceilings for gypsum board fire and sound stops and to form plenum areas as indicated.
- .9 Install wall furring for gypsum board wall finishes in accordance with ASTM C840, except where specified otherwise.
- .10 Furr openings and around built-in equipment, cabinets, access panels, on four sides. Extend furring into reveals. Check clearances with equipment suppliers.
- .11 Furr duct shafts, beams, columns, pipes and exposed services where indicated.
- .12 Erect drywall resilient furring transversely across studs, spaced maximum 600mm o.c. and not more than 150mm from ceiling/wall juncture. Secure to each support with 25mm drywall screw.
- .13 Install 150mm continuous strip of 12.7mm gypsum board along base of partitions where resilient furring installed.

#### 3.2 Application

- .1 Do not apply gypsum board until bucks, anchors, blocking, electrical and mechanical work are approved.
- .2 Apply single layer gypsum board to metal furring or framing using screw fasteners. Maximum spacing of screws 300mm o.c.
- .3 Apply single layer gypsum board to concrete/ concrete block surfaces, where indicated, using laminating adhesive.
- .4 **Apply impact resistant glass mat wall board on all vertical surfaces.**
- .5 **Apply tile backer board where ceramic tile is indicated to be installed.**
- .6 **Apply glass mat board on all other surfaces.**
- .7 Apply 12mm diameter bead of acoustic sealant continuously around periphery of each face of partitioning to seal gypsum board/structure junction where partitions abut fixed building components. Seal full perimeter of cut-outs around electrical boxes, ducts, etc., in partitions where perimeter sealed with acoustic sealant.

#### 3.3 Installation

- .1 Erect accessories straight, plumb or level, rigid and at proper plane. Use full length pieces where practical. Make joints tight, accurately aligned and rigidly secured. Mitre and fit corners accurately, free from rough edges. Secure at 150mm oc.
- .2 Install casing beads around perimeter of suspended ceilings.

- 
- .3 Install casing beads where gypsum board butts against surfaces having no trim concealing junction and where indicated. Seal joints with sealant.
  - .4 Install insulating strips continuously at edges of gypsum board and casing beads abutting metal window and exterior door frames, to provide thermal break.
  - .5 Construct control joints of preformed units set in gypsum board facing and supported independently on both sides of joint.
  - .6 Provide continuous polyethylene dust barrier behind and across control joints.
  - .7 Locate control joints where indicated on Drawings, at changes in substrate construction, **and** at approximate 10m spacing on long corridor runs and at approximate 15m spacing on ceilings. **Submit layout of control joints to Consultant for approval prior to commencement of the Work of this Section.**
  - .8 Install control joints straight and true.
  - .9 Install access doors to electrical and mechanical fixtures specified in respective Sections.
    - .1 Rigidly secure frames to furring or framing systems.
  - .10 Finish face panel joints and internal angles with joint system consisting of joint compound, joint tape and taping compound installed according to manufacturer's directions and feathered out onto panel faces.
  - .11 Finish corner beads, control joints and trim as required with two coats of joint compound and one coat of taping compound, feathered out onto panel faces.
  - .12 Fill screw head depressions with joint and taping compounds to bring flush with adjacent surface of gypsum board so as to be invisible after surface finish is completed.
  - .13 Sand lightly to remove burred edges and other imperfections. Avoid sanding adjacent surface of board.
  - .14 Completed installation to be smooth, level, plumb, free from waves and other defects and ready for surface finish.
  - .15 Mix joint compound slightly thinner than for joint taping.
  - .16 Where required by surface imperfections, apply thin coat to entire surface using trowel or drywall broad knife to fill surface texture differences, variations or tool marks.
  - .17 Allow skim coat to dry completely.
  - .18 Remove ridges by light sanding or wiping with damp cloth.
- 3.4 Fire Dampers
- .1 Refer to Mechanical Drawings for locations of fire dampers.
  - .2 Coordinate opening sizes for dampers to ULC clearance requirements.
  - .3 Line openings for dampers with type X board prior to damper installation.
- 3.5 Cleaning
- .1 Clean adjacent surfaces and remove excess materials, droppings and debris.
  - .2 Protect unfinished work.

END OF SECTION

## **PART 1 - GENERAL**

### 1.1 General

- .1 Conform to Division 01 – General Requirements.

### 1.2 Related Sections

- .1 Section 07 92 10 – Joint Sealing.
- .2 Section 09 21 16 – Gypsum Board Assemblies.

### 1.3 References

- .1 American Society for Testing and Materials (ASTM)
  - .1 ASTM C645 - 14e1, Standard Specification for Nonstructural Steel Framing Members.
  - .2 ASTM C754 - 18, Standard Specification for Installation of Steel Framing Members to Receive Screw-Attached Gypsum Panel Products.
- .2 CAN/CGSB-19.21-M87, Sealing and Bedding Compound Acoustical.

## **PART 2 - PRODUCTS**

### 2.1 Materials

- .1 Non-load bearing channel stud framing: to ASTM C645, stud size as indicated on drawings, roll formed with minimum base steel thickness 0.91mm (20ga) of hot dipped galvanized steel sheet, for screw attachment of gypsum board. Knock-out service holes at 460mm centres.
- .2 Floor and ceiling tracks: to ASTM C645, in widths to suit stud sizes, 32mm flange height.
- .3 Metal channel stiffener: 19mm x 9.5mm size, 1.4mm thick cold rolled steel, coated with rust inhibitive coating.
- .4 Acoustical sealant: to CAN/CGSB-19.21. Refer also to Section 07 92 00.
- .5 Insulating strip: rubberized, moisture resistant 3mm thick foam strip, 12mm wide, with self sticking adhesive on one face, lengths as required.

## **PART 3 - EXECUTION**

### 3.1 Erection

- .1 Align partition tracks at floor and ceiling and secure at 600mm o.c. maximum. Allow for 20mm deflection of floor and roof slabs.
- .2 Install dampproof course under stud shoe tracks of partitions on slabs on grade.
- .3 Place studs vertically at 400mm o.c. and not more than 50mm from abutting walls, and at each side of openings and corners. Position studs in tracks at floor and ceiling. Cross brace steel studs as required to provide rigid installation to manufacturer's instructions.
- .4 Erect metal studding to tolerance of 1:1000.
- .5 Attach studs to bottom and ceiling track using screws.

- 
- .6 Co-ordinate simultaneous erection of studs with installation of service lines. When erecting studs ensure web openings are aligned.
  - .7 Co-ordinate erection of studs with installation of door/ window frames and special supports or anchorage for work specified in other Sections.
  - .8 Provide two studs extending from floor to ceiling at each side of openings wider than stud centres specified. Secure studs together, 50mm apart using column clips or other approved means of fastening placed alongside frame anchor clips.
  - .9 Install heavy gauge single jamb studs at openings.
  - .10 Erect track at head of door/ window openings and sills of sidelight/ window openings to accommodate intermediate studs. Secure track to studs at each end, in accordance with manufacturer's instructions. Install intermediate studs above and below openings in same manner and spacing as wall studs.
  - .11 Frame openings and around built-in equipment, cabinets, access panels, on four sides. Extend framing into reveals. Check clearances with equipment suppliers.
  - .12 Provide 40mm stud or furring channel secured between studs for attachment of fixtures behind lavatory basins, toilet and bathroom accessories, and other fixtures including grab bars and towel rails, attached to steel stud partitions.
  - .13 Install steel studs or furring channel between studs for attaching electrical and other boxes.
  - .14 Extend **all** partitions to underside of structural deck.
  - .15 Maintain clearance under beams and structural slabs to avoid transmission of structural loads to studs. Use 50mm leg ceiling deflection tracks, with 75mm leg top track within. Attach studs to 75mm track.
  - .16 Install continuous insulating strips to isolate studs from uninsulated surfaces.
  - .17 Install two continuous beads of acoustical sealant under studs and tracks around perimeter of **all** partitions.

END OF SECTION

---

## **PART 1 - GENERAL**

### 1.1 General

- .1 Conform to Division 01 - General Requirements.

### 1.2 Related Sections

- .1 Section 09 21 16 – Gypsum Board Assemblies.
- .2 Section 09 51 13 – Acoustical Ceilings.
- .3 Divisions 21-23 – Mechanical: Trim for recessed mechanical fixtures.
- .4 Divisions 26-28 – Electrical: Trim for recessed electrical fixtures.

### 1.3 References

- .1 ASTM C635/ C635M - 17, Specifications for the Manufacture, Performance and Testing of Metal Suspension Systems for Acoustical Tile and Lay-In Panel Ceilings.
- .2 ASTM C636 / C636M - 13, Practice for Installation of Metal Ceiling Suspension Systems for Acoustical Tile and Lay-In Panels.

### 1.4 Design Requirements

- .1 Maximum deflection: 1/360th of span to ASTM C635 deflection test.

### 1.5 Extra Materials

- .1 Provide maintenance materials of acoustic tile ceiling panels in accordance with Section 01 78 00 - Closeout Submittals.
- .2 Provide 2% of each colour, pattern and type ceiling tile required for this project for maintenance use.
- .3 Extra materials to be from same production run as installed materials.
- .4 Clearly identify each container of ceiling tile.
- .5 Deliver to site, upon completion of the work of this section.
- .6 Store where directed by Consultant.

## **PART 2 - PRODUCTS**

### 2.1 Materials

- .1 Intermediate duty system to ASTM C 635.
- .2 Basic materials for suspension system: commercial quality cold rolled steel zinc-coated.
- .3 Suspension system: fire rated, for acoustical ceilings, made up as follows:
  - .1 main tees:
    - .1 0.53mm thick cold rolled steel, double web, with rectangular bulb section at least 43mm high. Fabricate with punched cross tee holes at not greater than 150mm o.c. and hanger wire holes at 50mm o.c. Exposed flange shall be 23.8mm wide cold rolled steel.
  - .2 cross tees:
    - .1 double web design with rectangular bulb, web extending to form a positive interlock with main tees, lower flange extended and offset to provide a flush intersection.
  - .3 Exposed tee bar grid components: die cut, shop painted satin sheen white.

- .4 Suspension system: non fire rated for gypsum board ceilings, made up as follows:
  - .1 main beams:
    - .1 0.53mm thick cold rolled steel, double web, with peaked roof top bulb at least 42.8mm high. Fabricate with punched cross tee holes at not greater than 150mm o.c. and hanger wire holes at 50mm o.c. Flange shall be 38mm wide knurled cold rolled steel.
  - .2 cross tees:
    - .1 double web design with peaked roof top bulb 38mm high, web extending to form a positive interlock with main tees. Flange shall be 38mm wide knurled cold rolled steel.
- .5 Hanger wire: galvanized soft annealed steel wire.
  - .1 3.6mm diameter to support max. weight of 110 kg/hanger.
  - .2 2.6mm diameter to support max. weight of 68 kg/hanger.
  - .3 galvanized annealed steel rod: 4.8mm diameter to support max. weight of 250kg/hanger.
- .6 Hanger inserts: purpose made.
- .7 Accessories: splices, clips, wire ties, retainers, and angle wall moulding.

### **PART 3 - EXECUTION**

#### 3.1 Installation

- .1 Installation: in accordance with ASTM C636 except where specified otherwise.
- .2 Install suspension system to manufacturer's instructions and Certification Organizations tested design requirements.
- .3 Install fire rated grid system in ceilings requiring a fire rating, as noted on Drawings.
- .4 Do not erect ceiling suspension system until work above ceiling has been inspected by Consultant.
- .5 Secure hangers to overhead structure. Do not use fasteners that will fracture structural members.
- .6 Install hangers spaced at maximum 1200mm centres and within 150mm from ends of main tees.
- .7 Lay out centre line of ceiling both ways, to provide balanced borders at room perimeter with border units not less than 50% of standard unit width if no reflected ceiling plan is provided.
- .8 Ensure suspension system is co-ordinated with location of related components.
- .9 Install wall moulding and trim to provide correct ceiling height.
- .10 Completed suspension system to support super-imposed loads, such as lighting fixtures diffusers, grilles and speakers.
- .11 Support at light fixtures and diffusers with additional ceiling suspension hangers within 150mm of each corner and at maximum 600mm around perimeter of fixtures.
- .12 Interlock cross member to main runner to provide rigid assembly.
- .13 Frame at openings for light fixtures, air diffusers, speakers and at changes in ceiling heights.
- .14 Finished ceiling system to be square with adjoining walls and level within 1:1000.

#### 3.2 Cleaning

- .1 Touch up scratches, abrasions, voids and other defects in painted surfaces.

END OF SECTION

## **PART 1 - GENERAL**

### 1.1 General

- .1 Conform to Division 01 - General Requirements.

### 1.2 Related Sections

- .1 Section 07 92 00 – Joint Sealing.
- .2 Section 09 21 16 – Gypsum Board Assemblies.

### 1.3 References

- .1 American Society for Testing and Materials (ASTM)
  - .1 ASTM C144, Standard Specification for Aggregate for Masonry Mortar.
  - .2 ASTM 207, Standard Specification for Hydrated Lime for Masonry Purposes.
- .2 American National Standards Institute (ANSI)
  - .1 ANSI A118.1, Specifications for Dry-Set Portland Cement Mortar.
- .3 Canadian General Standards Board (CGSB)
  - .1 CGSB 71-GP-22M, Adhesive, Organic, for Installation of Ceramic Wall Tile.
  - .2 CAN/CGSB-75.1- M88, Tile, Ceramic.
- .4 Canadian Standards Association (CSA)
  - .1 CAN/CSA-A5/A8/A362, Portland Cement/ Masonry Cement/ Blended Hydraulic Cement.

### 1.4 Samples

- .1 Submit samples in accordance with Section 01 33 00 - Submittal Procedures.
- .2 Submit duplicate samples of each colour, texture, size, and pattern of tile.

### 1.5 Extra Material

- .1 Provide maintenance materials in accordance with Section 01 78 00 - Closeout Submittals.
- .2 Provide minimum 2% of each type and colour of tile required for project for maintenance use. Store where directed.
- .3 Maintenance material to be of same production run as installed material.

### 1.6 Environmental Conditions

- .1 Maintain air temperature and structural base temperature at ceramic tile installation area above 12°C for 48 h before, during, and 48 h after, installation.

## **PART 2 - PRODUCTS**

### 2.1 Wall Tile

- .1 Ceramic tile (CT): to CAN2-75.1, Type 4, Class MR4, 100 x 300 x 6mm size, cushion edge, glazed, glossy finish and matt. Provide all trims, nosings, coves etc. necessary for complete installation.
  - .1 Approved products:
    - .1 ARKITEKT as distributed by Centura; allow for two Group 2 colours. Pattern and colours to be provided by Consultant.
    - .2 PLAIN as distributed by Olympia Tile; allow for two Group 2 colours. Pattern and colours to be provided by Consultant.
    - .3 COLOR WHEEL LINEAR as distributed by Daltile; allow for two Group 2 colours. Pattern and colours to be provided by Consultant.

---

2.2 Mortar, Grout Additives, Adhesives and Accessories

- .1 Tile Backer Board: TTMAC Detail 305W-2019-2021.
  - .1 Trowelable Underlayment and Patching Compound: Latricrete 3701, Mapei Mapecem mixed with Planicrete 50, or TA 305 Fast Set Deep Patch by TEC, HB Fuller.
  - .2 Thinset Mortar: Latricrete 4237 latex additive plus 211 Crete filler powder, Mapei Ultraflex LFT, or TA 382 Ultimate LFT by TEC, HB Fuller.
  - .3 Grout: Mapei UltracolorPlus wall grout or PowerGrout by TEC, HB Fuller; or Laticrete or Bostik approved equivalent.

2.3 Miscellaneous Materials

- .1 Sealants: in accordance with Section 07 92 00 – Joint Sealing.

**PART 3 - EXECUTION**

3.1 Workmanship

- .1 Do tile work in accordance with TTMAC (Terrazzo Tile and Marble Association of Canada) Specification Guide, Tile Installation Manual.
- .2 Apply tile or backing coats to clean and sound surfaces.
- .3 Fit tile around corners, fittings, fixtures, drains and other built-in objects. Maintain uniform joint appearance. Cut edges smooth and even.
- .4 Maximum surface tolerance 1:800.
- .5 Make joints between tile uniform and approximately 1.5mm wide, plumb, straight, true, even and flush with adjacent tile.
- .6 Lay wall tile in stack bond pattern.
- .7 Lay out tiles so perimeter tiles are minimum 1/2 size.
- .8 Sound tiles after setting and replace hollow-sounding units to obtain full bond.
- .9 Make internal angles square, external angles bullnosed. Use bullnose edged tiles at termination of wall tile panels, except where panel abuts projecting surface or differing plane.
- .10 Clean installed tile surfaces after installation and grouting cured.

END OF SECTION

---

**PART 1 - GENERAL**

1.1 General

- .1 Conform to Division 01 – General Requirements.

1.2 Related Sections

- .1 Section 09 30 13 – Ceramic Tile.

1.3 References

- .1 American National Standards Institute (ANSI)
  - .1 ANSI A118.1 - latest revision, Specifications for Dry-Set Portland Cement Mortar.
  - .2 ANSI A118.6 – latest revision, Specifications for Ceramic Tile Grouts.
- .2 Canadian General Standards Board (CGSB)
  - .1 CAN/CGSB-25.20 – latest revision, Surface Sealer for Floors.
  - .2 CAN/CGSB-75.1 – latest revision, Tile, Ceramic.
- .3 Canadian Standards Association (CSA)
  - .1 CAN/CSA-A5/A8/A362 – latest revision, Portland Cement/Masonry Cement/Blended Hydraulic Cement.
- .4 Terrazzo, Tile and Marble Association of Canada (TTMAC) Tile Installation Manual 2018-2019.

1.4 Submittals

- .1 Manufacturer's Instructions: Provide to indicate special handling criteria, installation sequence and cleaning procedures.

1.5 Samples

- .1 Submit samples in accordance with Section 01 33 00 - Submittal Procedures.
- .2 Submit duplicate 600mm x 600mm sample panels of each colour, texture, size and pattern of porcelain tile.
- .3 Adhere tile samples to 11mm thick plywood and grout joints to represent project installation.

1.6 Delivery, Storage and Handling

- .1 Deliver, store, handle and protect materials in accordance with Section 01 61 00 – Basic Product Requirements.
- .2 Deliver, store and handle products in manner to avoid damage.
- .3 Have materials delivered to job site just prior to installation.
- .4 Deliver all products to job site in manufacturer's unopened cartons with all labels intact and legible.
- .5 Keep cartons dry and protected from vandalism and away from heavy traffic areas.
- .6 Store cartons in upright position.

1.7 Environmental Requirements

- .1 Safety: Comply with requirements of Workplace Hazardous Materials Information System (WHMIS) regarding use, handling, storage, and disposal of materials.
- .2 Temperature.
  - .1 Maintain ambient temperature of not less than 12°C from 72 hours before installation until fully cured.

- .2 Maintain ambient temperature of not less than 5°C from 72 hours before installation until fully cured.
- .3 Maintain ambient temperature of not less than 20°C or above 35°C from 72 hours before installation until fully cured.

#### 1.8 Extra Materials

- .1 Provide maintenance materials of resilient tile flooring, base and adhesive in accordance with Section 01 78 00 - Closeout Submittals.
- .2 Provide 2% of each colour, pattern and type flooring material required for this project for maintenance use.
- .3 Extra materials to be from same production run as installed materials.
- .4 Clearly identify each container of floor tile and each container of adhesive.
- .5 Deliver to site, upon completion of the work of this section.
- .6 Store where directed by Consultant.

### **PART 2 - PRODUCTS**

#### 2.1 Tiles

- .1 Porcelain tile (PT): 610mm x 610mm x 9mm thick, base 100mm high; matt finish. Colours as selected by Consultant – colour as selected by Consultant.
  - .1 REGAL SERIES, as distributed by Olympia Tile, or approved alternate.

#### 2.2 Mortar, Grout and Adhesive Materials

- .1 Setting compound: TEC 487 Ultimate Six, grey colour, or approved alternate.
- .2 Grouting compound: TEC POWER GROUT, colour as selected by Consultant, or approved alternate.
- .3 Latex adhesives: TEC, or approved alternate.
- .4 Control joint sealant: in accordance with materials and procedures specified in section 07 92 10.

#### 2.3 Accessories

- .1 Tile Levelling System: 3mm (0.12") thick clips to match grout joint width with plastic wedge ratchet system equal to RLS Raimondi Levelling System.
- .2 Edge protection: by Schluter Systems Inc.
  - .1 All areas;
    - .1 Rondec profile; satin anodized aluminum RO125AE (horizontal and vertical edges)
    - .2 Rondec connectors; V/RO125
    - .3 Rondec outside corners; aluminum, double legged, E2L/RO125AE
    - .4 Rondec inside corners; aluminum, double legged, I2L/RO125AE
  - .2 Transitions: by Schluter Systems Inc.
    - .1 Porcelain to composite; RENO U AEU125
    - .2 Porcelain to concrete; RENO U AEU125
    - .3 Porcelain to carpet; RENO TK AETK125
- .3 Control Joints: 100% silicone sealant; TEC Accucolor 100, colour to match tile.

---

**PART 3 - EXECUTION**

3.1 Workmanship

- .1 Do tile work in accordance with TTMAC (Terrazzo Tile and Marble Association of Canada) Specification Guide, Tile Installation Manual, except where specified otherwise.
- .2 Apply or bond coat to clean and sound surfaces.
- .3 Fit tile units around corners, fittings, fixtures, drains and other built-in objects. Maintain uniform joint appearance. Make cut edges smooth and even.
- .4 Maximum surface tolerance: 1:800.
- .5 Make joints between tiles uniform and 3mm wide, plumb, straight, true, even and with adjacent units and joints flush to create smooth surface.
- .6 Lay out units so perimeter tiles are minimum 1/2 size.
- .7 Sound tiles after setting and replace hollow sounding units to obtain full bond.
- .8 Provide edges and trims at all interior and exterior corners.
- .9 Construct base with base cap at walls.
- .10 Install divider strips at junction of tile flooring and dissimilar material.
- .11 Clean installed tile surfaces after installation cured.
- .12 Seal flooring with penetrating sealer to sealer manufacturer's recommendations.

3.2 Setting System

- .1 Install tile and bases on substrate in accordance with TTMAC details.

3.3 Control Joints

- .1 Provide control joints 6mm wide at 5000mm intervals each way.
- .2 Provide control joints around perimeter of large areas, around columns, in locations where area changes direction and where tile abuts other hard material. Place control joints directly over subfloor expansion/control joints.
- .3 Provide control joints for all exterior areas at 3600mm intervals each way where indicated. Minimum width of control joints 10mm.
- .4 Fill joints with sealant.

3.4 Protection of Finished Work

- .1 Protect new floors from time of final set of adhesive until final inspection.
- .2 Prohibit traffic on floor for 48 hours after installation.

END OF SECTION

## **PART 1 - GENERAL**

### 1.1 General

- .1 Conform to Division 01 - General Requirements.

### 1.2 Related Sections

- .1 Section 09 21 16 – Gypsum Board Assemblies.
- .2 Section 09 22 27 – Acoustical Suspension.
- .3 Divisions 21-23 – Mechanical.
- .4 Divisions 26-28 – Electrical.

### 1.3 Samples

- .1 Submit samples in accordance with Section 01 33 00 - Submittal Procedures.
- .2 Submit duplicate full size samples of acoustical units.

### 1.4 Environmental Requirements

- .1 Permit wet work to dry before commencement of installation.
- .2 Maintain uniform minimum temperature of 15°C and humidity of 20-40% before and during installation.
- .3 Store materials in work area 48 hours prior to installation.

### 1.5 Extra Materials

- .1 Provide extra materials of acoustic units in accordance with Section 01 78 00 - Closeout Submittals.
- .2 Provide acoustical units amounting to 2% of gross ceiling area for each pattern and type required for project.
- .3 Extra materials to be from same production run as installed materials.
- .4 Clearly identify each type of acoustic unit, including colour and texture.
- .5 Deliver to Owner, upon completion of the work of this section.
- .6 Store as directed on site.

## **PART 2 - PRODUCTS**

### 2.1 Materials

- .1 Acoustic Units for suspended ceiling system:
  - .1 ACT1; Dune Fireguard, white, square edge, 610mm x 1220mm x 15.9mm, by Armstrong World Industries, Product Number 1851.
  - .2 ACT2; Kitchenzone, white, square edge, 610mm x 1220mm x 15.9mm, by Armstrong World Industries, Product Number 672.
  - .3 Acceptable Alternatives: CertainTeed, or Canadian Gypsum Company Limited; to match specified products.

### **PART 3 - EXECUTION**

#### 3.1 Examination

- .1 Do not install acoustical panels and tiles until work above ceiling has been inspected by Consultant.

#### 3.2 Installation

- .1 Install acoustical panels in ceiling suspension system.

#### 3.3 Application

- .1 Install acoustical units parallel to building lines with edge unit not less than 50% of unit width. Refer to Reflected Ceiling Plans.
- .2 Remove damaged and badly marked units and replace with new unmarked material.
- .3 Install components to form a level ceiling with all parts flush and true, parallel to the module lines and the pattern shown. Install panels in level, uniform plane free from twist, warp, dents and flush, without gaps. Fit border units neatly against abutting surfaces.
- .4 Scribe acoustic units to fit adjacent work. Butt joints tight, terminate edges with moulding.
- .5 Install retention clips at each panel as indicated in Room finish Schedule. Adapt installation to provide ceiling access where required for services.

#### 3.4 Interface with Other Work

- .1 Co-ordinate ceiling work to accommodate components of other sections, such as light fixtures, diffusers, speakers, sprinkler heads, to be built into acoustical ceiling components.

#### 3.5 Cleaning

- .1 After installation, clean and touch up minor surface defects on acoustical tile.
- .2 Remove damaged and badly marked units and replace with new unmarked material.

END OF SECTION

## **PART 1 - GENERAL**

### 1.1 General

- .1 Conform to Division 01 - General Requirements.

### 1.2 Related Sections

- .1 Divisions 20-23 and 26-28: Floor access covers.

### 1.3 References

- .1 American Society for Testing and Materials (ASTM)
  - .1 ASTM F 1066- 95a, Specification for Vinyl Composition Floor tile.
- .2 Canadian General Standards Board (CGSB)
  - .1 CAN/CGSB-25.20- 95, Surface Sealer for Floors.

### 1.4 Samples

- .1 Submit samples in accordance with Section 01 33 00 - Submittal Procedures.
- .2 Submit duplicate tile in size specified, 300mm long base, nosing, treads, edge strips.

### 1.5 Closeout Submittals

- .1 Provide maintenance data for resilient flooring for incorporation into manual specified in Section 01 78 00 - Closeout Submittals.

### 1.6 Environmental Requirements

- .1 Maintain air temperature and structural base temperature at flooring installation area above 20°C for 48 hours before, during and for 48 hours after installation.

### 1.7 Extra Materials

- .1 Provide maintenance materials of resilient tile flooring, base and adhesive in accordance with Section 01 78 00 - Closeout Submittals.
- .2 Provide 2% of each colour, pattern and type flooring material required for this project for maintenance use.
- .3 Extra materials to be from same production run as installed materials.
- .4 Clearly identify each container of floor tile and each container of adhesive.
- .5 Deliver to site, upon completion of the work of this section.
- .6 Store where directed by Consultant.

## **PART 2 - PRODUCTS**

### 2.1 Materials

- .1 Floor Patch
  - .1 Portland cement-based compound that has a minimal resistance to compression of 246 kg/cm<sup>2</sup> (3,500 lbs/sq. in.) to fill, smooth or level subfloor imperfections.

- .2 Resilient Sheet Flooring (RSF): to ASTM F 1913, 2000mm wide x 25000mm long roll, 2mm thickness homogenous sheet vinyl flooring, in standard colour selected by Consultant.
  - .1 SPHERA ELEMENT, as manufactured by Forbo.
  - .2 MIPOLAM AFFINITY, as manufactured by Gerflor.
  - .3 PALETTONE, as manufactured by Polyflor.
- .3 Rubber Wall Base (RB): to ASTM F1861, nominal thickness: 3mm (0.125") min. thickness; thermoset rubber (TS), coved, standard toe; height of new locations; 100mm high, existing locations to be reviewed for heights to ensure coverage of old base line, 150mm high (RB1). Colour: As selected by Consultant from manufacturer's complete range.
  - .1 PINNACLE as manufactured by Roppe.
  - .2 BASEWORKS as manufactured by Tarkett.
  - .3 OPTIMUM EDGE as manufactured by Mannington.
- .4 Primers and adhesives: waterproof, recommended by flooring manufacturer for specific material on applicable substrate, above, at or below grade.
- .5 Sub-floor filler and leveller: white premix latex requiring water only to produce cementitious paste as recommended by flooring manufacturer for use with their product.
- .6 Metal edge strips: aluminum extruded, smooth, polished with lip to extend under floor finish, shoulder flush with top of adjacent floor finish.
- .7 Reducer strips: wheelchair accessible rubber reducer strips by Johnsonite. Colour to be selected.
- .8 Sealer: type as recommended by flooring manufacturer.
- .9 Wax: type as recommended by flooring manufacturer.

### **PART 3 - EXECUTION**

#### **3.1 Examination**

- .1 Examine the subfloor before installation to ensure that the surface is clean, dry, smooth, structurally sound, and free from foreign substances, powder, scaling that may adversely affect adhesion or cause discoloration. Furthermore, ensure that the subfloor is free of paint, varnish, adhesive, oil, grease, solvent including treatment compounds, sealers and curing compounds that may adversely affect adhesion or alter the appearance or durability of the flooring.
- .2 Slabs that have been either using a curing agent or a sealer will have to be treated to ensure that the adhesion has not been impaired.
- .3 Measure the humidity and pH levels in the concrete in compliance with the following standards before installation:
  - .1 ASTM F2170, Relative Humidity (RH) test using in situ probes. The maximum allowable reading is 85% RH.
  - .2 ASTM F710, pH levels (test procedure 5.3.1). Preferred readings between 8 & 11.
  - .3 The ASTM test frequency recommendation is 3 tests for the first 92.9 sq. m and one test for each additional 92.9 sq. m.
- .4 Submit test results to Consultant in writing.
- .5 Report and rectify all unsatisfactory conditions. Do not start flooring installation until all rectifications have been completed.

#### **3.2 Preparation**

- .1 Mechanically remove all surface contaminants such as paint, varnish, adhesive, oil, grease, solvent as well as various other products such as treatment compounds.
- .2 Clean floor of dust, mold, mildew, alkaline salts, and other foreign material. Vacuum substrate.

- .3 Level all rough surfaces and fill cracks and marks with floor patch as specified. Trowel and float to leave a smooth, flat hard surface.
- .4 Ensure Moisture, Relative Humidity and pH tests have all been conducted and measurements meet manufacturer's recommendations.
- .5 In case of doubt, test the adhesion on the concrete subfloor or other surface that will be covered by the flooring. Do the test using the specified flooring and recommended adhesive.
- .6 Where floor substrate flatness and levelness tolerances do not meet minimum requirements to begin installation, prepare substrate in accordance with NFCA Floor Covering Reference Manual.

### 3.3 Application: Sheet Flooring

- .1 Provide a high ventilation rate, with maximum outside air, during installation, and for 48 to 72 hours after installation. If possible, vent directly to the outside. Do not let contaminated air recirculate through a district or whole building air distribution system. Maintain extra ventilation for at least one month following building occupation.
- .2 Apply adhesive uniformly using recommended trowel. Do not spread more adhesive than can be covered by flooring before initial set takes place.
- .3 Lay flooring to produce a minimum number of seams. Border widths to be minimum 1/3 width of full material.
- .4 Run sheets in direction of traffic. Double cut sheet joints and heat weld joints according to manufacturer's written instructions.
- .5 As installation progresses, and after installation roll flooring with 45kg minimum roller to ensure full adhesion.
- .6 Cut flooring neatly around fixed objects.
- .7 Install flooring in pan type floor access covers. Maintain floor pattern.
- .8 Continue flooring over areas which will be under built-in furniture.
- .9 Terminate flooring at centreline of door in openings where adjacent floor finish or colour is dissimilar.
- .10 Refer to Drawings for patterns/ insets. Patterns may include up to four different colours.
- .11 Install metal edge strips at unprotected or exposed edges where flooring terminates.

### 3.4 Base Application

- .1 Lay out base to keep number of joints at minimum. Base joints at maximum length available or at internal or premoulded corners.
- .2 Clean substrate and prime with one coat of adhesive.
- .3 Apply adhesive to back of base.
- .4 Set base against wall and floor surfaces tightly by using 3 kg hand roller.
- .5 Install straight and level to variation of 1:1000.
- .6 Scribe and fit to door frames and other obstructions.
- .7 Cope internal corners. Use premoulded corner units for right angle external corners. Use formed straight base material for external corners of other angles, minimum 300 mm each leg.

### 3.5 Initial Cleaning and Waxing

- .1 Remove excess adhesive from floor, base and wall surfaces with products and procedures recommended by manufacturer, without damage.
- .2 Clean, seal and wax floor and base surface to flooring manufacturer's instructions.

3.6 Protection of Finished Work

- .1 Protect new floors from time of final set of adhesive to after initial waxing until final waxing to final inspection.
- .2 Prohibit traffic on floor for 48 hours after installation.

END OF SECTION

---

**PART 1 - GENERAL**

1.1 General

- .1 Conform to Division 1 - General Requirements.

1.2 Related Sections

- .1 Section 07 92 10 - Joint Sealing.

1.3 References

- .1 Reference is made to standards produced by various organizations to conform to edition of standards specific or, if not specified, to last edition as amended and revised to date of contract.
  - .1 ACI Committee #503/pp1139-41
    - .1 Bond Strength: >2.8 MPa (100% concrete failure)
  - .2 ASTM C-307 - Tensile Strength: 15.17 MPa
    - .1 Test Method for Tensile Strength of Chemical Resistant Mortars, Grouts and Monolithic Surfacing.
  - .3 ASTM C-413 - Water Absorption: 0.2%
    - .1 Test Method for Absorption of Chemical Resistant Mortars, Grouts and Monolithic Surfacing.
  - .4 ASTM C-579 - Compressive Strength: 79.3 MPa
    - .1 Test Method for Compressive Strength of Chemical Resistant Mortars, Grouts and Monolithic Surfacing.
  - .5 ASTM C-580 - Flexural Strength: 34.5 MPa
    - .1 Test Method for Flexural Strength and Modulus of Elasticity of Chemical Resistant Mortars, Grouts and Monolithic Surfacing.
  - .6 ASTM D-635 - Flammability: Self Extinguishing. Extent of burning 6.4mm max.
    - .1 Test Method for Rate of Burning and/or Extent and Time of Burning of Self-Supporting Plastics in a Horizontal Position.
  - .7 ASTM D-790 - Flexural Modulus of Elasticity:  $11.7 \times 10^3$  MPa.
    - .1 Test Method for Flexural Properties of Unreinforced and Reinforced Plastics and Electrical Insulating Materials.
  - .8 ASTM D-2047 - Coefficient of Friction: 0.6
    - .1 Test Method for Static Coefficient of Friction of Polish-Coated Floor Surfaces as Measured by the James Machine.
  - .9 ASTM D-2240/Shore D. Durometer
    - .1 Hardness: 85-90
    - .2 Test Method for Rubber Property - Durometer Hardness
  - .10 ASTM D-4060, Taber Abrader CS-17 wheel, 1,000 gm load, 1,000 cycles
    - .1 Abrasion Resistance: 0.18 gm max. weight loss
    - .2 Test method for Abrasions Resistance of Organic Coatings by the Taber Abrader.
  - .11 ASTM E-831 - Thermal Coefficient of Linear Expansion:  $2.0 \times 10^{-5}$  m/m°C
    - .1 Test Method for Linear Thermal Expansion of Solid Materials by Thermochemical Analysis.
  - .12 Cure Rate (at 25°C) allow:
    - .1 6 hours for foot traffic
    - .2 18 hours for light traffic
    - .3 24 hours for normal operations
  - .13 Heat Resistance Limitation:
    - .1 93°C (for continuous exposure),
    - .2 122°C (for intermittent spills)
  - .14 MIL - D-3134F - Indentation: No Indentation.

- 
- 1.4 Submittals
- .1 Product Data: Submit manufacturer's technical data, installation instruction, and general recommendations for each epoxy flooring material required.
  - .2 Samples: Submit, for verification purposes, 300mm x 300mm square sample of each type of epoxy flooring required, applied to a rigid backing, in colour and finish indicated.
- 1.5 Quality Assurance
- .1 Single Source Responsibility: Obtain primary epoxy flooring materials including primers, resins, hardening agents, finish or sealing coats from a single manufacturer with not less than ten years of successful experience in manufacturing and installing principal materials described in this section. Contractor must have completed at least five projects of similar size and complexity; Sikafloor Quartzite or approved equal. Provide secondary materials only of type and from source recommended by manufacturer of primary materials.
    - .1 Arrange a meeting not less than thirty days prior to starting work.
- 1.6 Scope of Work
- .1 Refer to Room Finish Schedule for areas to receive an epoxy floor coating; areas shall be completed with SikaFloor Quartzite, as manufactured by Sika Corporation.
- 1.7 Delivery, Storage and Handling
- .1 Deliver material to job site. Flooring contractor will check material for completeness and shipping damage prior to job start.
  - .2 All materials must be factory pre-weighed and pre-packaged in single, easy to manage batches to eliminate on site mixing errors. No onsite weighing or volumetric measurements allowed.
  - .3 Store material in a dry, enclosed area protected from exposure to moisture. Temperature of storage area shall be maintained between 16 and 32°C.
- 1.8 Mock-up
- .1 At site, under manufacturer's supervision, apply for approval 9m<sup>2</sup> of complete floor finish in area designated, to match submitted samples. When approved, site applied sample to be standard for appearance, colour, texture, workmanship, etc., and all work to conform to this sample.
- 1.9 Project Conditions
- .1 Environmental Requirements:
    - .1 Concrete substrate must be properly cured for a minimum of 30 days.
    - .2 Temperature: Utilities, including electric, water, heat (air temperature between 16° and 32°C) and finish lighting to be supplied by General Contractor. Maintain ambient temperature of not less than 18°C and a floor temperature of not less than 16°C from (7) days before installation to at least 48 hours after completion of work and maintain relative humidity not higher than 40% during same period.
    - .3 Moisture: Ensure substrate is within moisture limits prescribed by (flooring) manufacturer.
  - .2 Safety: Comply with requirements of Workplace Hazardous Materials Information System (WHMIS) regarding the use, handling, storage and disposal of hazardous materials
  - .3 Job area to be free of other trades during, and for a period of 24 hours, after floor installation.

- 
- .4 Protection of finished floor from damage by subsequent trades is the responsibility of the General Contractor.
  - .5 Manufacturer's representative must be on job site at start of installation.
- 1.10 Warranty
- .1 Furnish a single, written warranty covering both material and workmanship for a period of three (3) full years from date of installation.
- 1.11 Inspections & Testing
- .1 Application of flooring may be subjected to material conformance and thickness testing.

## **PART 2 - PRODUCTS**

- 2.1 Epoxy Seamless Flooring (ESF)
- .1 Resinous flooring system: seamless, broadcast and sealed epoxy floor, composed of multicoloured quartz aggregates finished with transparent top coats applied, 3mm thickness.
    - .1 Approved product: Sikafloor Quartzite Broadcast System, or approved alternate to consist of the following components:
      - .1 Primer: Sikafloor® 161 applied between 8 – 10 mils.
      - .2 1<sup>st</sup> Body Coat: Sikafloor® 216 W/ Broadcast Decorative Quartz to Rejection applied at 16 mils.
      - .3 2<sup>nd</sup> Body Coat: Sikafloor® 216 W/ Broadcast Decorative Quartz to Rejection applied at 16 mils.
      - .4 Top Coat: Sikafloor® 216 applied at 16 mils.

## **PART 3 - EXECUTION**

- 3.1 Preparation
- .1 Substrate: Prepare concrete by mechanical means by using a shot blast machine for removal of bond inhibiting materials such as curing compounds or laitance.
- 3.2 Application
- .1 General: Apply each component of epoxy flooring system in compliance with manufacturer's directions to produce a uniform monolithic wearing surface of thickness indicated, uninterrupted except at divider strips, sawed joints or other types of joints (if any), indicated or required.
  - .2 Primer: Mix and apply primer over properly prepared substrate with strict adherence to manufacturer's installation procedures and coverage rates. Coordinate timing of primer application with application of troweled mortar to ensure optimum adhesion between epoxy flooring materials and substrate.
  - .3 Troweled Mortar: Mix mortar material according to manufacturer's recommended procedures. Uniformly spread mortar over substrate using manufacturer's specially designed screed box adjusted to manufacturer's recommended height. Hand trowel apply mixed material over freshly primed substrate using stainless steel finishing trowels.
  - .4 Undercoat: Remove any surface imperfections by lightly abrading and vacuuming the floor surface. Mix and apply undercoat with strict adherence to manufacturer's installation procedures and coverage rates.

- 
- .5 Broadcast: Immediately broadcast quartz silica aggregate into the undercoat using manufacturer's specially designed sprayer. Strict adherence to manufacturer's installation procedures and coverage rates is imperative.
  - .6 Terminate floors that do not abut against a vertical surface with a 13-19mm wide x 6mm deep chase.
  - .7 Cove Base: Install cover integral with the floor 100mm in height. All coves shall have integral troweled bullnosed terminations.
  - .8 Sealer: Remove excess unbonded granules by lightly brushing and vacuuming the floor surface. Mix and apply sealer with strict adherence to manufacturer's installation procedures.
  - .9 Joint Sealant: Install manufacturer's epoxy or urethane sealant compatible with floor finish.

### 3.3 Field Quality Control

- .1 The right is reserved to invoke the following material testing procedure at any time, and any number of times during period of flooring application.
- .2 The Owner will engage service of an independent testing laboratory to sample materials being used on the jobsite. Samples of material will be taken, identified and sealed, and certified in presence of Contractor.
- .3 Testing laboratory will perform tests for any of characteristics specified, using applicable testing procedures referenced herein, or if none referenced, in manufacturer's product data.
- .4 If test results show materials being used do not comply with specified requirements, Contractor may be directed by Owner to stop work; remove non-complying materials; pay for testing; reapply flooring materials to properly prepared surfaces which had previously been coated with unacceptable materials.

### 3.4 Curing, Protection and Cleaning

- .1 Cure epoxy flooring materials in compliance with manufacturer's directions, taking care to prevent contamination during stages of application and prior to completion of curing process. Close area of application for a minimum of 24 hours.
- .2 Protect epoxy flooring materials from damage and wear during construction operation. Where temporary covering is required for this purpose, comply with manufacturer's recommendations for protective materials and method of application. General Contractor is responsible for protection and cleaning of surfaces after final coats.
- .3 Cleaning: Remove temporary covering and clean epoxy flooring just prior to final inspection. Use cleaning materials and procedures recommended by epoxy flooring manufacturer.

END OF SECTION

---

## **PART 1 - GENERAL**

### 1.1 General

- .1 Conform to Division 01 – General Requirements.

### 1.2 Related Sections

- .1 Section 04 22 00 – Concrete Unit Masonry.
- .2 Section 06 40 00 – Architectural Woodwork.
- .3 Section 08 11 14 – Metal Doors and Frames.
- .4 Section 09 21 16 – Gypsum Board Assemblies.
- .5 Divisions 21-23/ 26-28: Mechanical and Electrical.

### 1.3 References

- .1 American Society for Testing and Materials (ASTM)
  - .1 ASTM D 3960 – 05(2013), Practice for Determining Volatile Organic Compound (VOC) Content of Paints and Related Coatings.
- .2 Canadian General Standards Board (CGSB)
  - .1 CAN/CGSB-1.36-97, General Purpose Interior Varnish.
  - .2 CAN/CGSB-1.38-2000, Interior Enamel Undercoater.
  - .3 CAN/CGSB-1.100-99, Interior Latex Type, Flat Paint.
  - .4 CAN/CGSB-1.119-2000, Primer-Sealer, Wall, Interior Latex Type.
  - .5 CAN/CGSB-1.145-97, Solvent-Based Pigmented Stain.
  - .6 CAN/CGSB-1.146-99, Cold Curing, Gloss Epoxy Coating.
  - .7 CAN/CGSB-1.150-M91, Clear Lacquer for Wood Furniture.
  - .8 CAN/CGSB-1.165-2004, Cold Curing Epoxy Primer.
  - .9 CAN/CGSB-1.188-2004, Emulsion Type Filler Masonry Block.
  - .10 CAN/CGSB-1.195-99, Interior Semigloss Latex Paint.
  - .11 CAN/CGSB-1.198-2001, Cementitious Primer (for Galvanized Surfaces).
  - .12 CAN/CGSB-1.209-2003, Low Sheen Latex Interior Paint.
  - .13 CAN/CGSB-85.10-99, Shop Painting Structural Steel.
- .3 Master Painters Institute (MPI).
  - .1 Architectural Painting Specification Manual.
- .4 Canadian Standards Association (CSA)
  - .1 CSA Z760-94 (R2001), Life Cycle Assessment.
- .5 Society for protective Coatings (SSPC).
  - .1 SSPC Painting Manual.

### 1.4 Description

- .1 Read carefully all other Sections of the Specifications to determine the extent of prime and finish coats applied by other Sections.
- .2 See Mechanical Divisions 21-23 and Electrical Division 26-28 for instructions on painting work to be done by Section 09 91 10 on surface provided by those Divisions.
- .3 Gloss range: paint and varnish textures are specified by their gloss type, which is defined by the dried film sheen factor. Refer to:
  - .1 MPI Painting Specification Manual - GLOSSARY OF TERMS to determine Sheen Factor for various gloss types.
  - .2 Locations A: Vest./ Corridors/ Stairs/ Washrooms/ Custodial/ Storage Areas
    - (1) block - MPI Gloss Level 7 (high gloss)
    - (2) gypsum board - MPI Gloss Level 3 (eggshell)
    - (3) doors/ frames - MPI Gloss Level 5 (semi gloss)
    - (4) wood - MPI Gloss level 5 (semi gloss)

- .3 Locations B: Remaining Areas
  - (1) block - MPI Gloss Level 5 (semi gloss)
  - (2) gypsum board - MPI Gloss Level 3 (eggshell)
  - (3) doors/ frames - MPI Gloss Level 5 (semi gloss)
  - (4) wood - MPI Gloss level 5 (semi gloss)

#### 1.5 Product Data

- .1 Submit product data in accordance with Section 01 33 00 – Submittal Procedures.
- .2 Submit full records of all products used. List each product in relation to finish formula and include the following:
  - .1 Finish formula designation.
  - .2 Product type and use.
  - .3 CGSB number.
  - .4 Manufacturer's product number.
  - .5 Colour numbers.
  - .6 Manufacturer's Material Safety Data Sheets (MSDS).
  - .7 Maximum VOC classification.
- .3 Submit manufacturer's application instructions for each product specified.

#### 1.6 Samples

- .1 Submit samples in accordance with Section 01 33 00 - Submittal Procedures.
- .2 Submit duplicate 300mm x 200mm sample panels of each paint, stain, clear coating, formula, type, colour, and texture specified.
- .3 Submit full range of available colours where colour availability is restricted.
- .4 Use 3mm plate steel for finishes over metal surfaces. Use 12.5mm maple plywood for finishes over wood surfaces. Use 12.5mm gypsum board for finishes over gypsum board and other smooth surfaces.

#### 1.7 Quality Assurance

- .1 Retain purchase orders, invoices and other documents to prove that all materials utilized in this contract meet requirements of the specifications. Produce documents when requested by Consultant.
- .2 Standard of Acceptance:
  - .1 Walls: No defects visible from a distance of 1000mm at 90° to surface.
  - .2 Ceilings: No defects visible from floor at 45° to surface when viewed using final lighting source.
  - .3 Final coat to exhibit uniformity of colour and uniformity of sheen across full surface area.

#### 1.8 Delivery, Storage and Handling

- .1 Deliver, store, handle and protect materials in accordance with Section 01 61 00 – Basic Product Requirements.
- .2 Deliver and store materials in original containers, sealed, with labels intact.
- .3 Indicate on containers or wrappings:
  - .1 Manufacturer's name and address.
  - .2 Type of paint.
  - .3 Compliance with applicable standard.
  - .4 Colour number in accordance with established colour schedule.
- .4 Remove damaged, opened and rejected materials from site.
- .5 Provide and maintain dry, temperature controlled, secure storage.
- .6 Observe manufacturer's recommendations for storage and handling.
- .7 Store materials and supplies away from heat generating devices.
- .8 Store materials and equipment in a well ventilated area with temperature range 7 - 30°C.

- .9 Store temperature sensitive products above minimum temperature as recommended by manufacturer.
- .10 Keep areas used for storage, cleaning and preparation, clean and orderly to approval of Consultant. After completion of operations, return areas to clean condition to approval of Consultant.
- .11 Remove only in quantities required for same day use.
- .12 Fire Safety Requirements:
  - .1 Store oily rags, waste products, empty containers and materials subject to spontaneous combustion in ULC approved, sealed containers and remove from site on a daily basis.
  - .2 Handle, store, use and dispose of flammable and combustible materials in accordance with the National Fire Code of Canada.

#### 1.9 Environmental Requirements

- .1 Safety: comply with requirements of Workplace Hazardous Materials Information System (WHMIS) regarding use, handling storage, and disposal of hazardous materials.
- .2 Apply paint finishes only when temperature at location of installation can be satisfactorily maintained within manufacturer's recommendations.
- .3 Substrate and ambient temperature must be within limits prescribed in paint standard and by manufacturer to approval of Consultant.
- .4 Maintain minimum substrate and ambient air temperature of 7°C for latex paints. Maximum relative humidity 85%. Maintain supplemental heating until paint has cured sufficiently.
- .5 Provide temporary heating where permanent facilities are not available to maintain minimum recommended temperatures.
- .6 Apply paint finish only in areas where dust is no longer being generated by related construction operations such that airborne particles will not affect the quality of the finished surface.
- .7 Apply paint only when surface to be painted is dry, properly cured and adequately prepared.
- .8 Provide minimum 270 lx on surfaces to be painted.

#### 1.10 Extra Materials

- .1 Submit maintenance materials in accordance with Section 01 78 00 – Closeout Submittals.
- .2 Submit one - four litre can of each type and colour of finish coating. Identify colour and paint type in relation to established colour schedule and finish formula.
- .3 Deliver to Site and store where directed.

## **PART 2 - PRODUCTS**

### 2.1 Paint Materials

- .1 Qualified products: only paint materials listed on the MPI Qualified Products List are acceptable for use on this project.
- .2 Qualified products: only varnish, stain, enamel, lacquer and filler materials listed on the MPI Approved Product Lists are acceptable for use on this project producing a flame spread rating of less 150.
- .3 Paint materials for each coating formula to be products of a single manufacturer.
- .4 Low odour products: Whenever possible, select products exhibiting low odour characteristics.

---

## 2.2 Paint Colours

- .1 Colours will be selected by Consultant. Note: There will be up to 6 different colours used.
- .2 Perform **all** colour tinting operations prior to delivery of paint to site.
- .3 Second coat in a three coat system to be tinted slightly lighter colour than top coat to show visible difference between coats.

## 2.3 Paint Finishes - INTERIOR

- .1 Concrete and Lightweight Block - Locations A – INT 4.2J Epoxy – Modified Latex, Interior, MPI Gloss Level 5 (semi-gloss)
  - .1 Two coats MPI #4; spray applied and back rolled to fill **all** pin holes, and as required by block texture.
  - .2 Two coats MPI #215; approved Devoe Coatings Tru-Glaze WB 4426 waterborne.
- .2 Concrete and Lightweight Block - Locations B – INT 4.2D Latex, Interior, High Performance Architectural, MPI Gloss Level 5 (semi-gloss)
  - .1 Two coats MPI #4; spray applied and back rolled to fill **all** pin holes, and as required by block texture.
  - .2 Two coats MPI #153; Interior, Acrylic #13210.
- .3 Gypsum Drywall – walls below 2400mm above finish floor – INT 9.2B Latex, Interior, High Performance Architectural, MPI Gloss Level 3 (eggshell)
  - .1 One coat MPI #50; Interior, Latex #59113
  - .2 Two coats MPI #153; Interior, Acrylic #13210.
- .4 Gypsum Drywall – walls above 2400mm above finish floor/ bulkheads/ ceilings – INT 9.2M Latex, Interior, Institutional, Low Odour/ VOC, MPI Gloss Level 1 (flat)
  - .1 One coat MPI #149; Interior, Latex #59113
  - .2 Two coats MPI #143; Interior, Acrylic #59111.
- .5 Metal (Ferrous) – INT 5.1B – Light Industrial Coating, Interior, Water Based, MPI Gloss Level 5 (semi-gloss)
  - .1 One coat MPI #107; approved – Pitt-Tech Int/Ext DTM Industrial #90-712
  - .2 Two coats MPI #153; approved – Dulux Diamond Interior Acrylic #13210.
- .6 Wood – Opaque Finish (P) – INT 6.3A – Latex High Performance Architectural, MPI Gloss Level 5 (semi-gloss)
  - .1 One coat primer; MPI #39; approved – Dulux Gripper #60000
  - .2 Two coats MPI #141; approved – Dulux Diamond Interior Acrylic #13210.
- .7 Exposed Insulated Pipes and Ductwork – INT 10.1A – Latex, Interior, Institutional, Low Odour/ VOC, MPI Gloss Level 1 (flat)
  - .1 One coat MPI #149; Interior, Latex #59113
  - .2 Two coats MPI # 143; Interior Acrylic #59111
- .8 Interior Copper and Aluminum (Mill Finish) – INT 5.4M - Latex, Interior, High Performance Architectural, MPI Gloss Level 5 (semi gloss)
  - .1 One coat MPI #95; approved Devoe Devguard #4630, Low VOC
  - .2 Two coats MPI #153; approved DULUX Diamond, Interior, Acrylic #13210
- .9 High Temperature Pipe and Fittings – INT 5.2 - Heat Resistant Enamel, 205°C (400°F)
  - .1 Two coats MPI #21; approved Devoe HT-4H High Temperature Silicone Acrylic.

## 2.4 Paint Finishes - EXTERIOR

- .1 Metal (Ferrous) - EXT 5.1 – Light Industrial Coating, Exterior, Water Based, MPI Gloss Level 5 (semi gloss)
  - .1 One coat MPI #107; approved Devoe Devflex #4020 DTM
  - .2 Two coats MPI #156; approved Devoe Devflex #4206 QD Exterior/ Interior Waterborne.

---

### **PART 3 - EXECUTION**

#### 3.1 General

- .1 Perform all painting operations in accordance with CAN/CGSB-85.100 except where specified otherwise.
- .2 Perform all painting operations in accordance with MPI Painting Specifications Manual except where specified otherwise.
- .3 Apply all paint materials in accordance with paint manufacturer's written application instructions.

#### 3.2 Preparation

- .1 Remove electrical cover plates, light fixtures, surface hardware on doors, door stops, bath accessories and all other surface mounted fittings and fastenings prior to undertaking any painting operations. Store for re-installation after painting is completed.
- .2 Move and cover furniture and portable equipment as necessary to carry out painting operations. Replace as painting operations progress.
- .3 As painting operations progress, place "WET PAINT" signs in occupied areas to approval of Consultant.

#### 3.3 Protection

- .1 Protect existing building surfaces not to be painted from paint spatters, markings and other damage. If damaged, clean and restore such surfaces as directed by Consultant.
- .2 Cover or mask floors, windows and other ornamental hardware adjacent to areas being painted to prevent damage and to protect from paint drops and splatters. Use non-staining coverings.
- .3 Protect items that are permanently attached such as Fire Labels on doors and frames.
- .4 Protect factory finished products and equipment.
- .5 Protect passing pedestrians, building occupants and the general public in and about the building.

#### 3.4 Conditions of Work

- .1 Investigate existing substrates for problems related to proper and complete preparation of surfaces to be painted. Report all damage, defects, unsatisfactory or unfavourable conditions before proceeding with work.
- .2 Investigate moisture content of surfaces to be painted and report findings. Do not proceed with work until conditions fall within acceptable range as recommended by manufacturer.
- .3 Maximum moisture content as follows:
  - .1 Plaster and wallboard: 12%.
  - .2 Masonry/Concrete: 12%.
  - .3 Concrete Block/Brick: 12%.
  - .4 Wood: 15%.

#### 3.5 Cleaning

- .1 Clean all surfaces to be painted as follows:
  - .1 Remove all dust, dirt, and other surface debris by vacuuming, wiping with dry, clean cloths or compressed air.
  - .2 Wash surfaces with solution of T.S.P. and clean warm water using a stiff bristle brush to remove dirt, oil and other surface contaminants.
  - .3 Rinse scrubbed surfaces with clean water until foreign matter is flushed from surface.
  - .4 Allow surfaces to drain completely and allow to dry thoroughly.
  - .5 To prepare surfaces for water-based painting, water-based cleaners should be used in place of organic solvents.

- .6 Use trigger operated spray nozzles for water hoses.
- .7 Many water-based paints cannot be removed with water once dried. However, minimize the use of kerosene or any such organic solvents to clean up water-based paints.
- .2 Prevent contamination of cleaned surfaces by salts, acids, alkalis, other corrosive chemicals, grease, oil and solvents before prime coat is applied and between applications of remaining coats. Apply primer, paint, or pre-treatment as soon as possible after cleaning and before deterioration occurs.
- .3 Sand existing surfaces with intact, smooth, high gloss coatings to provide adequate adhesion for new finishes.

### 3.6 Surface Preparation

- .1 Prepare new wood surfaces to CGSB 85-GP-1M.
- .2 Where possible, prime all surfaces of new wood surfaces before installation. Use same primers as specified for exposed surfaces.
- .3 Prepare previously painted wood surfaces to CGSB 85-GP-2M.
  - .1 Apply vinyl sealer to CAN/CGSB-1.126 over knots, pitch, sap and resinous areas.
  - .2 Apply wood filler to nail holes and cracks.
  - .3 Tint filler to match stains for stained woodwork.
- .4 Prepare stucco, brick, concrete masonry and concrete surfaces to CGSB 85-GP-31M.
- .5 Prepare concrete floors to CGSB 85-GP-32M. Prepare new concrete floor by acid etching. Rinse with clean water and thoroughly dry.
- .6 Prepare plaster and wallboard surfaces to CGSB 85-GP-33M.

### 3.7 Surface Preparation - Metal

- .1 Clean new metal surfaces to be painted by: removing rust, loose mill scale, welding slag, dirt, oil, grease and other foreign substances in accordance with the following:
  - .1 Solvent cleaning: SSPC-SP-1.
  - .2 Hand tool cleaning: SSPC-SP-2.
  - .3 Power tool cleaning: SSPC-SP-3.
  - .4 Commercial blast cleaning: SSPC-SP-6.
  - .5 Brush-off blast cleaning: SSPC-SP-7.
- .2 Touch up shop primer to CGSB 85-GP-10M with primer as specified in applicable section. Touch-up to include cleaning and painting of field connections, welds, rivets, nuts, washers, bolts, and damaged or defective paint and rusted areas.
- .3 Prepare galvanized steel and zinc coated steel surfaces to CGSB 85-GP-16M.
- .4 Prepare copper and copper alloys surfaces to CGSB 85-GP-20M.
- .5 Prepare new steel surfaces exposed normally to dry conditions to CGSB 85-GP-14M.
- .6 Prepare previously painted steel surfaces exposed normally to dry conditions to CGSB 85-GP-15M.
- .7 Prepare steel surfaces exposed to industrial environments to CGSB 85-GP-13M.
- .8 Prepare steel surfaces exposed to water or high humidity levels to CGSB 85-GP-11M  
CGSB 85-GP-18M.
- .9 Ductwork:  
Wash thoroughly all ductwork to be exposed and painted in completed work with mineral spirits and wipe dry with completely clean cloths. Phosphatize galvanized metal surfaces using CGSB-31-GP-116 pretreatment or prime with galvanized metal primer.
- .10 Do not apply paint until prepared surfaces have been accepted by Consultant.

### 3.8 Mixing Paint

- .1 Mix ingredients in container before and during use and ensure breaking up of lumps, complete dispersion of settled pigment, and uniform composition.
- .2 Thin paint for spraying according to manufacturer's instructions. If directions are not on container, obtain instructions in writing from manufacturer and provide copy of instructions to Consultant.

- .3 Do not use kerosene or any such organic solvents to thin water-based paints.

### 3.9 Application

- .1 Method of application to be as approved by Consultant. Apply paint by brushroller except where spraying is necessary to achieve acceptable finish. Conform to paint manufacturer's application instructions unless specified otherwise.
- .2 Brush/ roller application.
  - .1 Work paint into cracks, crevices and corners. Paint surfaces not accessible to brushes by spray, daubers or sheepskins.
  - .2 Brush out runs and sags.
  - .3 Remove runs, sags and brush marks from finished work and repaint.
- .3 Spray application.
  - .1 Provide 6mil poly dust curtains around rooms being sprayed to prevent transfer of paint and odour to other rooms.
  - .2 Provide and maintain equipment that is suitable for intended purpose, capable of properly atomizing paint to be applied, and equipped with suitable pressure regulators and gauges.
  - .3 Keep paint ingredients properly mixed in containers during paint application either by continuous mechanical agitation or by intermittent agitation as frequently as necessary.
  - .4 Apply paint in a uniform layer, with overlapping at edges of spray pattern.
  - .5 Brush out immediately all runs and sags.
  - .6 Use brushes to work paint into cracks, crevices and places which are not adequately painted by spray.
- .4 Use dipping, sheepskins or daubers only when no other method is practical in places of difficult access and only when specifically authorized by Consultant.
- .5 Apply each coat of paint as a continuous film of uniform thickness. Repaint thin spots or bare areas before next coat of paint is applied.
- .6 Allow surfaces to dry and properly cure after cleaning and between subsequent coats for minimum time period as recommended by manufacturer.
- .7 Sand and dust between each coat to remove visible defects.
- .8 Finish tops of cupboards, cabinets and projecting ledges, both above and below sight lines as specified for surrounding surfaces.
- .9 Finish inside of cupboards and cabinets as specified for outside surfaces.
- .10 Finish closets and alcoves as specified for adjoining rooms.
- .11 Finish top, bottom, edges and cutouts of doors after fitting as specified for door surfaces.
- .12 Apply final coat of paint after inspection and correction of deficiencies and installation of flooring have been completed.

### 3.10 Mechanical and Electrical Equipment

- .1 In finished areas: paint exposed conduits, piping, hangers, ductwork and other mechanical and electrical equipment. Colour and texture to match adjacent surfaces, except as noted otherwise.
- .2 In boiler room, mechanical and electrical rooms: paint exposed conduits, piping, hangers, ductwork and other mechanical and electrical equipment.
- .3 In other unfinished areas: leave exposed conduits, piping, hangers, ductwork and other mechanical and electrical equipment in original finish and touch up scratches and marks.
- .4 Touch up scratches and marks on factory painted finishes and equipment with paint as supplied by manufacturer of equipment.
- .5 Do not paint over nameplates.
- .6 Keep sprinkler heads free of paint.
- .7 Paint inside of ductwork where visible behind grilles, registers and diffusers with primer and one coat of matt black paint.
- .8 Paint disconnect switches for fire alarm system and exit light systems in red enamel.
- .9 Paint all fire protection piping red, unless directed otherwise.
- .10 Paint all natural gas piping yellow, unless directed otherwise.

- .11 Paint both sides and edges of backboards for telephone and electrical equipment before installation. Leave equipment in original finish except for touch-up as required, and paint conduits, mounting accessories and other unfinished items.
- 3.11 Field Quality Control
- .1 Field inspection of painting operations to be carried out by independent inspection firm as designated by Consultant.
  - .2 Advise Consultant when each applied coating is ready for inspection. Do not proceed with subsequent coats until previous coat has been approved.
  - .3 Co-operate with inspection firm and provide access to all areas of the work.
- 3.12 Restoration
- .1 Clean and re-install all hardware items that were removed before undertaken painting operations.
  - .2 Remove protective coverings and warning signs as soon as practical after operations cease.
  - .3 Remove paint splashings on exposed surfaces that were not painted. Remove smears and spatter immediately as operations progress, using compatible solvent.
  - .4 Protect freshly completed surfaces from paint droppings and dust to approval of Consultant. Avoid scuffing newly applied paint.
  - .5 Restore areas used for storage, cleaning, mixing and handling of paint to clean condition as approved by Consultant.

END OF SECTION

---

## **PART 1 – GENERAL**

### 1.1 General

- .1 Conform to Division 01 – General Requirements.

### 1.2 Reference Standards

- .1 American National Standards Institute (ANSI):
  - .1 ANSI A208.2, Medium Density Fibreboard for Interior Use.
- .2 ASTM International:
  - .1 ASTM A924/A924M, Standard Specification for General Requirements for Sheet Steel, Metallic-Coated by the Hot-Dip Process.
- .3 Porcelain Enamel Institute (PEI):
  - .1 PEI 501 Properties of Porcelain Enamel.
- .4 Underwriters' Laboratories of Canada (ULC):
  - .1 CAN/ULC-S706.1:2020, Standard for Insulating Wood Fibre Boards for Buildings.

### 1.3 Related Sections

- .1 Section 04 22 00 – Concrete Unit Masonry.

### 1.4 Approved Manufacturers

- .1 The following manufacturers are approved subject to meeting requirements of this Section:
  - .1 ASI Group Canada Inc.; 866-858-0083; info@asigroup-canada.com.
  - .2 CPE Design Solutions Inc.; 905-844-3535; info@claridge.ca.
  - .3 Global School Products; 905-212-9314; ofajardo@globalschoolproducts.com; wayne@globalschoolproducts.com.

### 1.5 Submittals

- .1 Submit in accordance with 01 33 00 – Submittal Procedures and as follows:
  - .1 Product Data:
    - .1 Submit manufacturer's instructions, printed product literature and data sheets for visual display boards and include product characteristics, performance criteria, physical size, finish, and limitations.
  - .2 Shop Drawings:
    - .1 Submit drawings that include plans, elevations, sections, and attachment details.
    - .2 Indicate location, type, size, panel arrangement, backing, hardware, anchor or mounting details, frame or trim, and accessories.
  - .3 Samples:
    - .1 Submit a 300mm square sample of each type of display board including face sheets and core material.

### 1.6 Quality Assurance

- .1 Certificates: Submit product certificates signed by manufacturer certifying materials comply with specified performance characteristics and criteria and physical requirements.

1.7 Pre-Installation Meeting

- .1 Conduct a meeting 2-3 weeks prior to installation commencing with the Owner and Consultant, and general contractor in accordance with 01 31 00 – Project Managing and Coordination to review the following:
  - .1 Review locations of all visual display boards.
  - .2 Review height requirements located in primary versus senior grades.

1.8 Environmental Requirements

- .1 Deliver, store, and handle materials in accordance with Section 01 61 00 – Product Requirements, with manufacturer’s written instructions.

1.9 Close-Out Submittals

- .1 Submit maintenance data for incorporation into Operations and Maintenance manual in accordance with Section 01 78 10 – Close-Out Submittals and Requirements.
  - .1 Include maintenance and cleaning data for each visual display board.

**PART 2 – PRODUCTS**

2.1 Materials

- .1 Whiteboard:
  - .1 Finish: Porcelain enamel coating to comply with PEI 501 for durability, smoothness, colour continuity, and satin (matte) gloss factor. Colour; white
  - .2 Face sheet: commercial grade, 0.38mm (28ga) minimum thickness to ASTM A924M with Z275 zinc coating.
  - .3 Core material: fibreboard to CAN/ULC-S706, 11mm (0.44”) thick, impregnated.
  - .4 Backer Sheet: commercial grade, 0.38mm (28ga) minimum thickness to ASTM A924M with Z275 zinc coating.
- .2 Chalkboard:
  - .1 Finish: Porcelain enamel coating to comply with PEI 501 for durability, smoothness, colour continuity, and matte gloss factor. Colour; black
  - .2 Face sheet: commercial grade, 0.38mm (28ga) minimum thickness to ASTM A924M with Z275 zinc coating.
  - .3 Core material: fibreboard to CAN/ULC-S706, 11mm (0.44”) thick, impregnated.
  - .4 Backer Sheet: commercial grade, 0.38mm (28ga) minimum thickness to ASTM A924M with Z275 zinc coating.
- .3 Tackboard:
  - .1 Face sheet: 6mm (1/4”) thick, single layer natural cork, large granular sheet. Colour; natural.
  - .2 Core material: 6mm (1/4”) thick, Medium Density Fibreboard to ANSI A208.2.
  - .3 Backer Sheet: none.
- .4 Laminating adhesive: to manufacturer’s recommendations.
- .5 Framing: extruded aluminum to alloy AA6063-T5, 1.5mm (1/16”) thick minimum perimeter trim or frame of manufacturer’s standard sections. Finish; clear anodized.
  - .1 Flat tray: extruded aluminum to alloy AA6063-T5, 3mm (1/8”) thick minimum, bottom trim with integral tray 90mm (3.5”) deep with end closures, running full length of panel bottom of manufacturer’s standard sections. Finish; clear anodized.

- .6 Anchor clips, brackets, and fasteners: concealed type recommended by manufacturer for fixed mounting.

## 2.2 Fabrication

- .1 Fabricate visual display panels to sizes indicated on drawings.
- .2 Factory laminate visual display panels, consisting of facing sheet, core material, and backing sheet of balanced thicknesses (same thickness) to prevent panel warpage using adhesive in accordance with manufacturer's recommendations.
- .3 Make finished panels flat and rigid, this is critical as panels may be used to project a video image onto the surface without distortion of the image.
- .4 Install trim on panels in factory. Make corner mitres and joints to hair-line fit, free of rough edges. Use concealed brackets to reinforce and hold joints tight and flush.
- .5 Overlap trim 6mm (1/4") onto panels.
  - .1 Include closed ends for trays and open-end extrusions.

## **PART 3 – EXECUTION**

### 3.1 Examination

- .1 Verification of Conditions: verify that conditions of substrate previously installed under other Sections are acceptable for visual display board installation in accordance with manufacturer's written instructions.
  - .1 Inform General Contractor and Consultant of unacceptable conditions immediately upon discovery.
  - .2 Proceed with installation only after unacceptable conditions have been remedied.

### 3.2 Manufacturer's Instructions

- .1 Compliance: comply with manufacturer's written data, including product technical bulletins, product catalogue installation instructions, product carton installation instructions, and data sheets.

### 3.3 Installation

- .1 Install visual display boards in accordance with manufacturer's instructions, parallel to floor, plumb and level, to provide rigid, secure writing surface.
  - .1 Special care to be used when whiteboards are being used as a projection screen to ensure projected image remains true and flat without any distortion. Shim panel as necessary to ensure panel remains flat, true, and smooth.
- .2 Install trim around visual display boards.
  - .1 Install appropriate trays where required along bottom of board.
  - .2 Make mitres and joints to hair-line fit, free of rough edges.
  - .3 Use concealed brackets to reinforce and hold joints tight and flush.
  - .4 Overlap trim 6mm onto panels.
- .3 Mechanical attachment:
  - .1 To concrete or solid masonry: use lag screw and expansion bolts or screws and lead expansion shields as appropriate for stresses involved.
  - .2 To hollow masonry: Use toggle bolts or screws and lead expansion shields as appropriate for stresses involved.
  - .3 To sheet metal: use screws secured into framing members in stud walls.

3.4 Cleaning

- .1 Progress Cleaning: clean in accordance with Section 01 74 00 – Cleaning and Waste Management.
  - .1 Leave work area clean at the end of each day.
- .2 Final Cleaning: upon completion remove surplus materials, rubbish, tools and equipment in accordance with Section 01 74 00 – Cleaning and Waste Management.

3.5 Protection

- .1 Protect installed products and components from damage during construction.
- .2 Repair damage to adjacent materials caused by visual display board installation.
- .3 Remove protective film on visual display boards just prior to occupancy of building.
  - .1 Chalk-in chalkboards by chalking entire face of each chalkboard.

END OF SECTION

## **PART 1 - GENERAL**

### 1.1 General

- .1 Conform to Division 01 - General Requirements.

### 1.2 Related Sections

- .1 Section 06 10 10 – Rough Carpentry.
- .2 Section 09 30 13 – Ceramic Tile.

### 1.3 References

- .1 American Society for Testing and Materials (ASTM)
  - .1 ASTM A167 - 99(2009), Standard Specification for Stainless and Heat-Resisting Chromium-Nickel Steel Plate, Sheet, and Strip.
  - .2 ASTM B456 - 17, Standard Specification for Electrodeposited Coatings of Copper Plus Nickel Plus Chromium and Nickel Plus Chromium.
  - .3 ASTM A 653/ A653M - 17, Standard Specification for Steel Sheet, Zinc-Coated (Galvanized) or Zinc-Iron Alloy-Coated (Galvannealed) by the Hot-Dip Process.
  - .4 ASTM A924/ A924M - 17a, Standard Specification for General Requirements for Steel Sheet, Metallic-Coated by the Hot-Dip Process.
- .2 Canadian General Standards Board (CGSB)
  - .1 CAN/CGSB-1.81-M90, Air Drying and Baking Alkyd Primer for Vehicles and Equipment.
  - .2 CAN/CGSB-1.88-92, Gloss Alkyd Enamel, Air Drying and Baking.
  - .3 CAN/CGSB-12.5-M86, Mirrors, Silvered.
  - .4 CGSB 31-GP-107Ma, Non-inhibited Phosphoric Acid Base Metal Conditioner and Rust Remover.
- .3 Canadian Standards Association (CSA)
  - .1 CAN/CSA-B651-12 (R2017), Barrier-Free Design.
  - .2 CAN/CSA-G164-M92 (R2003), Hot Dip Galvanizing of Irregularly Shaped Articles.

### 1.4 Shop Drawings

- .1 Submit shop drawings in accordance with Section 01 33 00 Submittal Requirements.
- .2 Indicate size and description of components, base material, surface finish inside and out, hardware and locks, attachment devices, description of rough-in-frame, building-in details of anchors for grab bars.

### 1.5 Samples

- .1 Submit samples in accordance with Section 01 33 00 Submittal Requirements.
- .2 Samples to be returned for inclusion into work.

### 1.6 Closeout Submittals

- .1 Provide maintenance data for toilet and bath accessories for incorporation into manual specified in Section 01 78 00 – Closeout Submittals.

### 1.7 Extra Materials

- .1 Provide special tools required for accessing, assembly/disassembly or removal for toilet accessories in accordance with requirements specified in Section 01 78 00 – Closeout Submittals.

- .2 Deliver special tools to Owner.

#### 1.8 Acceptable Products

- .1 Products listed are based on Bobrick model numbers, unless noted otherwise.
- .2 Products manufactured by Saferail and Watrous/ ASI meeting or exceeding specified performance are acceptable.

### **PART 2 - PRODUCTS**

#### 2.1 Materials

- .1 Sheet steel: to ASTM A 653/A653M with G90 designation zinc coating.
- .2 Stainless steel sheet metal: to ASTM A 167, Type 302, with No.4 finish.
- .3 Stainless steel tubing: Type 304, commercial grade, seamless welded, 1.2mm wall thickness.
- .4 Fasteners: concealed screws and bolts hot dip galvanized, exposed fasteners to match face of unit. Expansion shields fibre, lead or rubber as recommended by accessory manufacturer for component and its intended use.

#### 2.2 Components

- .1 Toilet tissue dispenser: Supplied by Owner, installed by Contractor.
- .2 Soap dispenser: Supplied by Owner, installed by Contractor.
- .3 Paper towel dispenser: Supplied by Owner, installed by Contractor.
- .4 Feminine napkin disposal bin: Supplied by Owner, installed by Contractor.
- .5 Grab bars: 38mm dia x 1.6mm wall tubing of stainless steel, 76mm diameter wall flanges, concealed screw attachment, flanges welded to tubular bar, provided with steel back plates and all accessories. Knurl bar at area of hand grips. Grab bar material and anchorage to withstand downward pull of 2.2 kN.
  - .1 Acceptable material: Type GB1: Bobrick Model No: 5898.99; Type GB2: Bobrick Model No. B-5806.99x24.
- .6 Mirror (MIR.1): wall mounted unit, fixed framed mirror 6mm to CAN/CGSB-12.5, stainless steel frame.
  - .1 Acceptable material: Bobrick - Model No. B-165 2436.
- .7 Tilt mirror (MIR.2): wall mounted unit, fixed framed mirror 6mm to CAN/CGSB-12.5, stainless steel frame.
  - .1 Acceptable material: Bobrick Model No. B-293 2436.

#### 2.3 Fabrication

- .1 Weld and grind joints of fabricated components flush and smooth. Use mechanical fasteners only where approved.
- .2 Wherever possible form exposed surfaces from one sheet of stock, free of joints.
- .3 Brake form sheet metal work with 1.5mm radius bends.
- .4 Form surfaces flat without distortion. Maintain flat surfaces without scratches or dents.
- .5 Back paint components where contact is made with building finishes to prevent electrolysis.
- .6 Hot dip galvanize concealed ferrous metal anchors and fastening devices to CSA G164.
- .7 Shop assemble components and package complete with anchors and fittings.
- .8 Deliver inserts and rough-in frames to job site at appropriate time for building-in. Provide templates, details and instructions for building in anchors and inserts.
- .9 Provide steel anchor plates and components for installation on studding and building framing.

2.4 Finishes

- .1 Chrome and nickel plating: to ASTM B456, satin finish.
- .2 Manufacturer's or brand names on face of units not acceptable.

**PART 3 - EXECUTION**

3.1 Installation

- .1 Install and secure accessories rigidly in place as follows:
  - .1 Stud walls: install 19mm plywood blocking to/ between studs prior to plaster or drywall finish.
  - .2 Hollow masonry units or existing plaster/drywall: use toggle bolts drilled into cell/wall cavity.
- .2 Install grab bars on built-in anchors provided by bar manufacturer.
- .3 Use tamper proof screws/bolts for fasteners.
- .4 Fill units with necessary supplies shortly before final acceptance of building.

3.2 Schedule

- .1 Locate accessories where indicated on Drawings. Exact locations determined by Consultant.

END OF SECTION

## **PART 1 - GENERAL**

### 1.1 General

- .1 Conform to Division 1 – General Requirements.

### 1.2 Related Sections

- .1 Section 06 10 10 – Rough Carpentry.
- .2 Section 09 21 16 – Gypsum Board Assemblies.
- .3 Section 09 22 16 – Non-Structural Metal Framing.

### 1.3 References

- .1 Canada Consumer Product Safety Act: Corded Window Coverings Regulations: SOR/2019-97.

### 1.4 Submittals

- .1 Submit Product Data in accordance with Section 01 33 00, consisting of Manufacturer's data sheets on each product to be used, including:
  - .1 Preparation instructions and recommendations.
  - .2 Styles, material descriptions, dimensions of individual components, profiles, features, finishes and operating instructions.
  - .3 Storage and handling requirements and recommendations.
  - .4 Mounting details and installation methods.
  - .5 Maintenance Data: Submit Methods for maintaining roller shades, precautions regarding cleaning materials and methods, instructions for operating hardware to include with Closeout Submittals Section 01 78 10.

### 1.5 Quality Assurance

- .1 Manufacturer Qualifications: Obtain roller shades through one source from a single manufacturer with a minimum of ten years experience in manufacturing products comparable to those specified in this Section.
- .2 Installer Qualifications: Installer trained and certified by the manufacturer with a minimum of ten years experience in installing products comparable to those specified in this Section.
- .3 Fire-Test-Response Characteristics: Passes NFPA 701-99 small and large scale vertical burn. Materials tested shall be identical to products proposed for use.

### 1.6 Delivery, Storage and Handling

- .1 Deliver shades in factory-labeled packages, marked with manufacturer and product name, fire-test-response characteristics, and location of installation using same room designations indicated on Drawings.

### 1.7 Warranty

- .1 Manufacturer shall provide warranty that all components are free of manufacturing defects for two years from the date of Substantial Performance.

---

## **PART 2 - PRODUCTS**

### 2.1 Manufacturers

- .1 This specification is based on LeGrand Solarfective Products Ltd. Manual Teleshades. Similar products by the following manufacturers will also be acceptable without requiring a request for substitution:
  - .1 Altex SunProject Deko Shade System
  - .2 Hunter Douglas RB500 Shade system.

### 2.2 Manually Operated Shade Components

- .1 Visually Transparent Single-Fabric Shadecloth: single thickness non-raveling 0.762mm thick vinyl fabric, woven from 0.457mm diameter extruded vinyl yarn comprising of 21% polyester and 79% reinforced vinyl, in colours selected from manufacturer's available range. 3% Open. Colour as selected by Consultant from standard product range.
- .2 Shade Bands: Construction of shade band includes the fabric, the hem weight, hem-pocket, shade roller tube, and the attachment of the shade band to the roller tube. Sewn hems and open hem pockets are not acceptable.

### 2.3 Hem Pockets and Hem Weights:

- .1 Fabric hem pocket with RF-welded seams (including welded ends) and concealed hem weights. Hem weights shall be appropriate size and weight for shade band. Hem weight shall be continuous inside a sealed hem pocket. Hem pocket construction and hem weights shall be similar, for all shades within one room.

### 2.4 Shade Band and Shade Roller Attachment:

- .1 Use extruded aluminum shade roller tube of a diameter and all thickness required to support shade fabric without excessive deflection. Roller tubes less than 39mm in diameter for manual shades are not acceptable.
- .2 Provide for positive mechanical engagement with drive/brake mechanism.
- .3 Provide for positive mechanical attachment of shade band to roller tube; shade band shall be made removable/replaceable with a "snap-on" "snap off" spline mounting, without having to remove shade roller from shade brackets.
- .4 Mounting spline shall not require use of adhesives, adhesive tapes, staples, and/or rivets.
- .5 Any methods of attaching shade band to roller tube that requires the use of: adhesive, adhesive tapes, staples, and/or rivets are not acceptable.

## **PART 3 - EXECUTION**

### 3.1 Examination

- .1 Do not begin installation until substrates have been properly prepared.
- .2 If substrate preparation is the responsibility of another installer, notify Consultant of unsatisfactory preparation before proceeding.

### 3.2 Preparation

- .1 Clean surfaces thoroughly prior to installation.
- .2 Prepare surfaces using the methods recommended by the manufacturer for achieving the best result for the substrate under the project conditions.

3.3 Installation

- .1 Install manually operated shades complete with fascia and blackout shades complete with side and sill channels level, plumb, square, and true according to manufacturer's written instructions, and located so shade band is not closer than 50mm to interior face of glass. Allow proper clearances for window operation hardware.

3.4 Protection

- .1 Protect installed products until completion of project.
- .2 Touch-up, repair or replace damaged products before Substantial Completion.

3.5 Locations

- .1 Provide fabric window shades on all new exterior windows.

END OF SECTION

## **1. GENERAL**

### 1.1 General Requirements

- .1 This general division, Division 20 – Mechanical, applies to the following detailed divisions:
  - a. Division 21 – Fire Suppression
  - b. Division 22 – Plumbing
  - c. Division 23 – Heating, Ventilation and Air Conditioning
  - d. Division 25 – Integrated Automation
- .2 Comply with the conditions of Division 0 and Division 1.
- .3 Specifications and drawings form an integral part of the contract documents. Any item omitted from one but which is mentioned or reasonably implied in the other, shall be considered as properly and sufficiently specified and shall be included as part of the work.
- .4 Maintain at site, one copy of the following:
  - a. Mechanical contract documents.
  - b. Reviewed shop drawings.
  - c. Supplementary instructions, Proposed Change and Change Orders.
  - d. Other modifications to Contract.
  - e. Field and laboratory test reports.
  - f. Approved mechanical permit drawings.
  - g. As-built drawings.
  - h. Drawing documents approved by any applicable authorities.

### 1.2 Cash Allowances

- .1 Refer to Division 1 for cash allowance details.

### 1.3 Liability and Property Insurance

- .1 Comply with the requirements of Division 0, Division 1 and Section GC 11.1 of CCDC 2 - 2020.
- .2 This Contractor shall assume all liability for and be responsible for loss of or damage to the Contractor's materials or equipment and for any materials delivered to the Contractor from whatever source to the site of the Work.

### 1.4 Workplace Safety and Insurance Board

- .1 This Trade shall produce a Workplace Safety and Insurance Board Certificate of Clearance Form at each monthly progress draw and prior to final payment under the contract.

### 1.5 Subcontractors

- .1 This Contractor shall provide a complete and firm list of the names and addresses of the Subcontractors whom will be used for the Work. This Contractor shall incorporate all the terms and conditions of the Contract necessary for the purpose of performing the Work

pursuant to the Contract into all sub-contract agreements. Nothing contained in the Contract shall create any contractual relationship between any Subcontractor and the Owner.

#### 1.6 Indemnification Claims

- .1 This Trade shall indemnify and save harmless the Owner and its respective officers and agents from all claims relating to labour and material furnished or supplied in executing the contract, and from and against all claims, demands, losses, costs, damages, actions, suits or proceedings by whomsoever made, brought or prosecuted in any manner based upon, arising out of, relating to, occasioned by or attributable to the activities or omissions of this Trade or those for whom this Trade is at law responsible in performing the contract.
- .2 Comply also with Section GC 12.1 of CCDC 2 - 2020.

#### 1.7 Use of Electronic Files

- .1 A waiver must be executed prior to release of any electronic documentation.
- .2 Electronic documentation for release may consist of drawing files in formats such as a Portable Document File (PDF), AutoCAD (dwg), Revit (rvt). Specifications, details, schedules, legends shall generally NOT be released.
- .3 Electronic documents shall be used only for the specific use outlined in the waiver. The recipient may use this data for this purpose, at their own risk.
- .4 Copyright and ownership of the data are not transferred to the recipient, or to any other party. The design professional and/or owner retain all rights to the data.
- .5 Data delivered in electronic form may vary from those contained on paper copies of the documents. This information is not guaranteed to be accurate. The method of data transfer cannot be guaranteed to be error free, or compatible with the recipient's hardware, software, or systems. Contractors and subcontractors are not relieved of their normal responsibilities to independently check, coordinate, and verify information and dimensions, and to familiarize themselves thoroughly with the project. The documents may have been changed or amended by addendums, bulletins, RFIs, shop drawings, other documents, meetings, and understandings not represented on these files.
- .6 The electronic files shall not be used as a substitute for the contract documents. The Author offers no warranty or guarantee, express, implied, or statutory as to the accuracy, reliability, suitability, completeness or fitness of this data for a particular purpose. The company in receipt of these files agrees, to the fullest extent permitted by law, to defend, indemnify, and hold the Author, their directors, officers, partners, employees, harmless from all losses, claims, liabilities, injuries, damages, and expenses, including attorneys' fees and costs of defense, arising out of the use, misuse, misapplication, or misinterpretation of this data.
- .7 The recipient will not distribute the data to any other firm or individual, except the recipient's consultants or subcontractors.

#### 1.8 Definitions

- .1 "Provide" means to supply and install the products and services specified.
- .2 "The Work" means the total construction required by the Contract Documents and includes all labour, Products and services.
- .3 "Products" means all material, equipment and fixtures forming the completed Work as required by the Contract Documents.

#### 1.9 Quality Assurance

- .1 The physical properties, design, performance and characteristics of Products of this Division and their installation shall be as specified and in accordance with the applicable requirements and recommendations of the latest issue of all relevant regulations, including but not limited to:
  - a. National Fire Protection Association Codes
  - b. Canadian Standards Association (CSA)
  - c. American National Standards Institute (ANSI)
  - d. American Society for Testing and Materials (ASTM)
  - e. American Society of Mechanical Engineers (ASME)
  - f. Ontario Building Code (OBC)
  - g. Ontario Fire Code
  - h. Ontario Ministry of Labour Codes
  - i. Ontario Gas Utilization Code
  - j. Ontario Occupational Health and Safety Act
  - k. Technical Standards and Safety Authority (TSSA).
  - l. All Municipal regulations and any authorities having jurisdiction.

#### 1.10 Intent

- .1 Provide all products specified or shown in the contract documents complete with incidentals necessary for a complete operating installation. Provide all tools, instruments, equipment and labour required to do the work.
- .2 The contract documents are not intended to enumerate each and every detail which may be necessary to furnish and install the complete system ready for operation. The bid price shall include all such details, and all associated labour and materials, to provide a complete and working system. The omission of any details in the contract documents shall not be a warrant for poor workmanship or the omission of such details.
- .3 The final decision as to which trade provides required labour or materials rests solely with the Contractor. Where Work is assigned to specific Sections within this specification, it is to be used as a guide only to assist the Sub-Contractors with their coordination. Extra payments will not be considered based on a difference in interpretation of the contract documents as to which trade involved provides materials or labour for specific items of Work. The Consultant will not enter into such discussions.
- .4 Wherever differences occur in the contract documents, the maximum conditions will govern and shall be allowed for in the bid price. The items to be incorporated will be at the option of the Consultant.

- .5 All Work shall be carried out by qualified Trades and Sub-trades with established reputations for the type of work involved and performed to good industry standards.
- .6 All Work shall conform to standards of excellence and good practice of the respective trades. Governing codes and regulations represent the minimum acceptable standards.

#### 1.11 Examination of Site and Contract Documents

- .1 It is the responsibility of this Trade to carefully review the drawings, specifications and other instructions and notify the Owner in writing of any errors, omissions and discrepancies prior to closing of tenders. This Trade shall abide by the decision given in writing. The work as shown is intended to be completed in all respects and that failure to notify the Owner of any discrepancies will not relieve this Trade of responsibility for completing the work as intended. In no case shall this Trade proceed in uncertainty.
- .2 This Trade shall visit the building and become thoroughly familiar with all the existing mechanical systems and other conditions to be met in carrying out the work covered by these specifications prior to submitting the bid price. Arrangements for a site inspection may be made as described in Division 1.
- .3 Examine all mechanical specification divisions and sections and all other related contract documents. The mechanical specification is to be read in conjunction with all other divisions and sections of the specification. In the event of conflict between documents, this specification shall govern.
- .4 Mechanical drawings are not to be scaled. Refer to architectural drawings for all dimensions.

#### 1.12 Scope of Work

- .1 Comply with the latest requirements of all relevant standards and codes of the authorities having jurisdiction. These standard codes and regulations constitute an integral part of these specifications. If the Contractor knowingly performs any work contrary to these laws and fails to notify the Consultant in writing and obtain their direction in writing, the Contractor shall be responsible for and shall correct any violations thereof and shall bear all costs, expense and damages attributable to the Contractor's failure to comply with the provisions of all such laws.
- .2 Inform the Consultant in writing if modifications to the Work are requested by the authorities.
- .3 Submit all required documentation to the authorities for their approval and comment before starting any Work. Provide all additional drawings, details or information as may be required.
- .4 Supply Certified Mechanics and Apprentices in accordance with the latest Department of Labour Regulations.
- .5 Provide all equipment and materials as specified and / or shown on the drawings and required to provide complete, properly functioning, mechanical systems fit to the intended use. Provide all labour for the satisfactory completion of the work. Supply any miscellaneous equipment and materials not herein listed necessary for the proper installation and operation of the systems.

- .6 General product requirements:
  - a. Provide only new products. Where a manufacturer is not specified provide products of high commercial standard and quality consistent with the standards of these specifications.
  - b. All products must bear the approval of the CSA or have special approval of the inspection authority having jurisdiction for their respective functions and environments.
  - c. Provide products of same manufacture for like applications unless noted otherwise.
  - d. All products must comply with all applicable energy efficiency codes.
  
- .7 All deposits, levies or similar fees, if any, required for completion of the Mechanical Work shall be paid as follows. Apply for all necessary permits.
  - a. Unless otherwise indicated, fees required for the approval, registration and inspection of any portion of the mechanical system by any government agency, department or authority shall be included in the tender price. The Mechanical Contractor shall make all necessary arrangements with TSSA and provide all necessary documentation without extra cost as required for approval / inspection / registration of applicable mechanical systems and any equipment or materials subject to the requirements of O. Reg. 220/01 under the TSSA Act, 2000.
  - b. Fees required for approval and inspection of sprinkler / standpipe system(s) shall be included in the bid price except that all fees required for review of system(s) by the insurance underwriters shall be paid by the Owner directly to the underwriter.

#### 1.13 Acceptable Products

- .1 Unless noted otherwise, the bid price may be based on the use of products equal to those specified herein. Where 'approved equals' are listed, only products from these manufacturers may be used in the bid price. Where approved equals are not listed, any manufacturer may be used in the bid price.
  
- .2 Unless specifically stated otherwise, this project has been designed based on the first named manufacturer of each section or that specifically listed in the schedules. If this Trade chooses to use a manufacturer other than the first named manufacturer, it will be their responsibility to ensure that all equal and alternative equipment meets the mechanical specification, is similar in dimensions, stability, quality, weight, ease of maintenance, performance, etc. and that the equipment will fit into the space allocated. This Trade shall be responsible for preparing revised design drawings (if directed by the Consultant) and shall carry all costs required to accommodate the equal / alternative equipment INCLUDING ALL COSTS INCURRED BY OTHER TRADES. The Consultant reserves the right to approve or reject any alternate based upon his evaluation of the equipment proposed. If only one manufacturer is listed, then only that manufacturer shall be acceptable.

#### 1.14 Contract Drawings

- .1 The drawings show the approximate location for the equipment and materials throughout the building. The arrangement shown on the drawings is diagrammatic and approximate only. All Work shall be coordinated on site with the Work of other Divisions prior to installation. Unless

otherwise indicated on the drawings, the elevation and exact plan location of services shall be determined by the Contractor.

- .2 Items shown on the drawings but not specified or specified but not shown shall be included. Items obviously required to provide a complete working system but not specified nor shown shall be included.
- .3 Where any parts of the system and / or pieces of equipment are located by dimensions on the drawings, the dimensions shall be checked and verified in the field.
- .4 Adjust the location of materials and / or equipment to accommodate structural conditions, other equipment / systems, etc. as directed without adjustment to contract price provided that the changes are requested before installation and they do not significantly affect the quantity of materials. Extra charges will not be accepted for adjustment of materials and / or equipment that are required due to the lack of proper site coordination.

#### 1.15 Coordination

- .1 Review the specifications and drawings of all divisions and become thoroughly acquainted with the Work.
- .2 Coordinate the Work with all Divisions. Inform other Divisions of equipment locations, opening locations, sleeve locations, supports, connections, electrical data, piping / duct locations, etc. Coordinate in order to eliminate any unnecessary delays to any Work.
- .3 All ductwork and piping shall be routed on site to clear other piping, ductwork, building structure, etc. Note that drawings are schematic in nature only and that all work must be coordinated on site and adjusted without extra cost.
- .4 Before commencing any Work of this Division, inform the Consultant in writing of any detrimental factors affecting the Work.

#### 1.16 Construction (Interference) Drawings

- .1 Prepare construction drawings where required or where directed for proper coordination of the Work. Submit construction drawings prior to commencement of Work.
- .2 Where directed by the General Contractor or Consultant, prepare fully dimensioned construction drawings of:
  - a. Products and services in mechanical rooms, service / ceiling spaces and other critical locations.
  - b. Pits, curbs, sills, equipment bases, anchors, inertia slabs, etc.
  - c. Sleeves and openings through structure.
  - d. Alternate / equal products and associated systems.
- .3 Coordinate the Work with all other Divisions. Base drawings on reviewed shop drawings and indicate all details pertaining to access clearances, cleanouts, electrical / drain / water / ductwork connections, final piping / ductwork layouts, etc.

- .4 Submit construction drawings to all Divisions. Construction drawings must be submitted electronically in editable Portable Document Format (.PDF) format. All construction drawings submitted for the complete project shall be in the same format.
- .5 Construction drawings are prepared for construction and record purposes only and are not part of the contract documents or shop drawings.

#### 1.17 Shop Drawings

- .1 Refer to other Sections of this specification for equipment / fixtures requiring shop drawing submittal.
- .2 Shop Drawings shall be submitted electronically in editable Portable Document Format (.PDF).
- .3 The Consultant's review of shop drawings and manufacturer's specifications is general and is not intended to serve as the final check. It shall not relieve the Contractor from responsibility for errors.
- .4 Equipment will not be accepted on site until approval of shop drawings. Do not proceed with work on any item for which shop drawing approval has not been given.
- .5 Before submission, check all shop drawings for accuracy of details, dimensions, etc. Circulate shop drawings which affect the Work of other Divisions for their review and comments prior to submission to the Consultant. The Consultant will only review shop drawings bearing the Contractors stamp of approval.
- .6 Any deviations whatsoever from items specified to that proposed on the Shop Drawings shall be clearly identified and listed in red ink on the front of the Shop Drawings.
- .7 Indicate the manufacturer's estimated time of delivery, expressed in weeks after receipt of approved shop drawings. As more accurate delivery times become known during the course of the Contract, notify the Consultant and General Contractor. Equipment with long delivery dates that are critical for the progress of the work are to be followed closely by the Contractor. Submit their shop drawings as soon as possible, separating them from the bulk of all other equipment and marking "Urgent" on the front page of the submission. Assume full responsibility for submission of shop drawings. Allow two (2) weeks for Consultants review.
- .8 Submit shop drawings showing the following:
  - a. Project name
  - b. Project equipment number, manufacturer's name and model number
  - c. Supplier's name
  - d. Approval agencies
  - e. Shipping and working weight
  - f. Performance characteristics
  - g. Dimensions
  - h. Accurate wiring diagrams and electrical requirements for all electrical components.
  - i. Materials used in manufacture and type of finish
  - j. Time required to fabricate and deliver
  - k. All variations from tender documents

i. Applicable standards such as CSA, CGA, ULC, ANSI, ASTM, ASME, FM, etc.

.9 Drawings will be marked and action taken as follows:

Consultant's Markings	Action by Contractor
.1 Reviewed	Proceed with work.
.2 Reviewed as noted	Proceed in accordance with markings. Resubmit revised drawings for record.
.3 Revise and Resubmit	Submit revised drawings for review before proceeding.

.10 Shop drawings shall be submitted for all products (including all associated accessories, controls, etc.), including but not limited to:

- a. Plumbing fixtures including trim.
- b. Emergency showers / eyewashes.
- c. Mixing valves.
- d. Plumbing specialties.
- e. Hydronic heaters.
  - i. Wallfins / convectors.
  - ii. Radiant ceiling panels.
- f. Grilles / diffusers.
- g. Motorized dampers.
- h. Fire dampers.
- i. Combination fire and smoke dampers.
- j. Access doors.
- k. Kitchen hoods including fire suppression systems.
- l. Fans.
- m. Rooftop units.
- n. Energy recovery ventilators.
- o. Building automation system including all components, wiring diagrams, sequences and points lists.
- p. Firestopping systems.
- q. Sprinkler systems, including:
  - i. Design drawings and details (drawn to scale and showing the size / location of all system components including piping / fittings, sprinkler heads, valves, flow switches, pre-action system alarm valve / control panel / smoke detectors / air compressor, pumper connection, backflow preventer, etc.).
  - ii. Calculations.
  - iii. Tamper / pressure / flow switches.
  - iv. Sprinkler heads complete with guards.
  - v. Valves.
  - vi. Gauges.
  - vii. Grooved joint couplings and fittings.
  - viii. Sprinklers shall be referred to on drawings, submittals and other documentation, by the sprinkler identification or model number as

specifically published in the appropriate agency listing or approval. Trade names or other abbreviated designations shall not be allowed.

- .11 For firestopping systems, shop drawings shall show construction conditions, relationships to adjoining construction, dimensions, description of materials and finishes, component connections, anchorage methods, hardware and installation procedures, plus the following:
  - a. Firestop design designation of testing and inspecting agency acceptable to the authorities having jurisdiction.
  - b. Documentation, including illustrations, from a qualified testing and inspection agency that is applicable to each firestop system configuration for construction and penetrating items. Factory or manufacturer furnished installation details are not acceptable in lieu of published documents by approved testing agencies.
  - c. Where conditions require modification of a qualified testing and inspecting agency's illustration to suit a particular firestop condition, submit illustration, with modifications marked, approved by the firestop system manufacturer's fire-protection Engineer.

#### 1.18 Schedule

- .1 Where specified in Division 0 or Division 1, all work shall be scheduled to meet the required project milestones.
- .2 All work in existing facilities shall be performed at times to suit the Owner and must not interfere in any way with the carrying on of business.
- .3 Extra charges for premium time labour shall be included in the tender price as required to comply with the construction schedule and the restrictions on when work will be permitted in the existing building. Allow for after hours, weekend and holiday labour requirements.

#### 1.19 Payment Certification

- .1 Submit a sample progress draw to the Consultant within one week of award of contract for review and approval.
- .2 Submit monthly progress draws to the Consultant for review and certification. Monthly progress draws shall resemble approved sample progress draw.
- .3 Submit a breakdown of the contract price into classifications to the satisfaction of the Consultant, with the aggregate of the breakdown totalling the total contract amount. Each item shall be broken out into material and labour costs. This breakdown will be used in computing of progress payments. Progress claims shall be itemized against each item of the contract breakdown (this shall be done in table form showing contract amount, work complete to date, previous draw, amount this draw and balance).

#### 1.20 Extras and Credits

- .1 For each change submit a complete itemized breakdown of labour and material costs, overhead and profit markup, and taxes.

- .2 Only the net difference between an extra and a credit will subject to overhead and profit mark-up.
- .3 Material shall be valued at current trade prices incorporating all discounts.
- .4 Labour rates shall be valued at payroll cost plus a percentage mark-up for burden as stipulated in Division 0.
- .5 Labour rates for extras and credits shall be identical.
- .6 Approval must be obtained from the Consultant prior to work commencing. Refer to Division 0 for additional information.

#### 1.21 Questions

- .1 Questions pertaining to the work shall be submitted to the Consultant in writing in the form of a Request for Information (RFI).
- .2 Allow for two weeks for RFI response from the Consultant. Claims for delay within this period will not be accepted.

#### 1.22 Operation and Maintenance Manual

- .1 Provide the complete manual in electronic PDF format on a suitably sized USB thumb drive.
- .2 Make all corrections requested by the Consultant and resubmit all corrected copies for final approval.
- .3 Include the following information in or with each manual.
  - a. Valves
    - i. Complete list of all valves, strainers, etc. indicating manufacturer, type, catalogue number, source of supply and maintenance data.
  - b. Instrumentation and Control
    - i. Complete list of all gauges, thermometers, thermostats, sensors, control dampers / actuators, controllers and other instruments / control components indicating manufacturer, catalogue number, source of supply and maintenance data (where applicable).
    - ii. Sequences and description of operation for each control system including all settings.
    - iii. Schematic diagram for each control system complete with equipment / parts listing.
    - iv. For additional requirements, refer to Division 25.
  - c. Reports
    - i. Inspection reports from Authorities having Jurisdiction.
    - ii. Sign-back of latest mechanical and electrical Site Review Report(s).
    - iii. Water analysis / treatment reports for bacteria / chlorine in domestic water system.
    - iv. Lead sampling reports in accordance with O. Reg. 243/07.
    - v. Maximum water temperature at fixtures.

- vi. Air and water testing, adjusting and balancing (TAB) report.
- vii. Firestop manufacturer sign-off.
- viii. Pipe pressure test reports.
- d. Miscellaneous
  - i. Identify cover with "Operation and Maintenance Manual".
  - ii. Provide Letter of Guarantee from the date of substantial completion and the name, address and telephone number of the company providing the warranty.
  - iii. Include index sheet.
  - iv. Provide tabbed format.
  - v. Include name and address of closest service organization and spare parts source for each item of equipment.
  - vi. Provide list of all Subcontractors providing mechanical work, including address, telephone number and contact name.
  - vii. Provide list of all main equipment suppliers, including address, telephone number and contact name.
  - viii. Provide voltage and ampere rating for each item of electrical equipment.
  - ix. For all equipment required to have shop drawing approval, include in each tabbed section the following manufacturers information:
    - 1) Approved shop drawings.
    - 2) Manufacturers installation manual.
    - 3) Manufacturers operation and maintenance manual.
    - 4) Manufacturers standard and / or extended warranty slips.
    - 5) Manufacturers start-up sheets where available (completed by the Contractor).
  - x. Provide list of motors serving mechanical equipment, including:
    - 1) Location of motor.
    - 2) Name of unit served by motor.
    - 3) Motor serial number, manufacturer.
    - 4) Horsepower, voltage, full load current, service factor and rpm of motor (nameplate data), rating and catalogue number of motor starter thermal overload relays.
  - xi. Provide list of belts serving mechanical equipment, including quantity, size and identification number.

### 1.23 As-built Drawings

- .1 Obtain and pay for one set of blueprints, for job use only, on which to record accurately all deviations from the contract drawings. At all times have these prints available for inspection at the site. At the completion of the project, these plans shall be converted to electronic AutoCAD (release 12 or later) drawing format. Electronic base plans shall be provided from the Consultant at no cost (all work relating to the modification of these plans to reflect as-built conditions shall be at the expense of the Contractor). Provide to the Owner one (1) complete set of drawings in both electronic format and hard copy (paper) full size plots.
- .2 With all progress claims certify in writing that record drawings coincide with progress of the Work.
- .3 Prepare as-built drawings showing the following:

- a. Dimensions of underground services in relation to building lines at key reference points of every run.
  - b. Dimensioned location of all services embedded in the structure.
  - c. Dimensioned location of all services left for future work.
  - d. All changes to the Work due to change orders.
  - e. All changes to the Work due to addendums.
  - f. All changes to the Work during construction.
- .4 Provide one (1) full size paper copy of all final "as-built" record drawings to the Consultant for approval purposes. Make all changes directed prior to submission to the Owner.
- .5 The Consultant shall provide, at no cost, AutoCAD drawing files incorporating Changes and Instructions.
- .6 Generation of AutoCAD as-built drawings may be arranged with the Consultant.

#### 1.24 Identification

- .1 General:
- a. All identification labels shall be easily and accurately readable from usual operating areas, plane of legend to be approximately at right angles to most convenient line of sight. Wording of all labels shall be approved by the Consultant prior to manufacture.
  - b. Identify the complete sprinkler systems to the standards listed above and as specified in Division 21.
  - c. Verify all identification labels / tags on site with the maintenance staff and adjust as required to be consistent with the existing identification system. Update existing valve directories to accommodate the new work.
  - d. All mechanical equipment (including VVT system automatic control dampers, in-line fans, isolation / balancing valves, major components of the building automation system, etc.) requiring access for maintenance / adjustment and located above the acoustic tile ceiling shall be identified with 0.25" (6mm) diameter coloured markers with adhesive backing. Colour of markers shall be red.
- .2 Pipe identification:
- a. Identify pipe mains by means of pressure sensitive adhesive labels. Markers and flow arrows shall be in accordance with ANSI/ASME A13.1 latest edition. Identify medium by lettered legend and direction of flow by arrows. Provide labels as follows:
    - i. At intervals not greater than 50 ft (15 m), changes of direction, upstream of major manually / automatically operated control valves, at all branch pipe connections, behind all access doors and on both sides where pipes pass through walls. Use approximate spacing intervals of 25 ft (7.6 m) for all piping running through suspended ceiling spaces.
  - b. Labels shall be sized as follows (pipe diameter includes insulation where applicable):
    - i. 0.75" (19 mm) to 1.25" (32 mm) piping:
      - 1) Minimum 8" (200 mm) long label with minimum 0.5" (13 mm) letter height.
    - ii. 1.5" (38 mm) to 2" (50 mm) piping:

- 
- 1) Minimum 8" (200 mm) long label with minimum 0.75" (19 mm) letter height.
  - iii. 2.5" (63 mm) to 6" (150 mm) piping:
    - 1) Minimum 12" (300 mm) long label with minimum 1.25" (32 mm) letter height.
  - c. All identification labels shall be easily and accurately readable from usual operating areas, plane of legend to be approximately at right angles to most convenient line of sight.
  - d. Wording of all labels shall be approved by the Consultant prior to manufacture.
  - e. Optionally, piping may be identified using stencils and stencil marking ink. Location and sizing shall conform to pipe label specification. On insulated surfaces stencilling shall be done with black ink, on uninsulated pipe the ink shall be white. Ensure stencilling is performed in a neat, quality manner. Upon completion of project, turn over one complete set of stencils matching those used on the project to the building Owner.
  - f. Piping requiring identification is as follows:
    - i. Domestic cold water (hard and soft).
    - ii. Domestic hot water (high and low temperature).
    - iii. Domestic recirculating hot water.
    - iv. Non-potable water.
    - v. Hot water heating supply / return.
    - vi. Natural gas piping to Code requirements. Note that all outside piping shall be painted.
    - vii. All natural gas piping shall be identified according to Code and local authorities requirements and as follows:
- .3 Valve identification:
- a. Valve identification shall consist of a 1.25" (32 mm) diameter brass tag with engraved black paint filled characters, secured to valve by a brass bead chain. Provide and mount for the Owner a typed valve directory in a black document type frame, listing valve number, location and service. Locate the framed directory in the main mechanical room and provide a master directory to be included in the Operation and Maintenance Manual. Individual fixture supply stops and radiation valves shall not be identified.
- .4 Identification of equipment / systems shall be as follows:
- a. Identification plates shall be engraved two-ply plastic, 0.125" (3 mm) thick, 1.0" (25 mm) high with 3/4" (19 mm) white characters on black background and length as required. Locate in a conspicuous location and secure with self-tapping sheet metal screws to equipment. All screws used outside shall be stainless steel. Nameplates which are not exposed to outdoor conditions may be secured with double sided adhesive tape. All starters shall be identified by the Electrical Trade.
  - b. All equipment with symbols included in drawing schedules or plans shall be identified to match symbols indicated.
  - c. The following items shall be tagged at installed location and keyed to a control wiring diagram. Diagram shall be included in the Operation and Maintenance Manual:
    - i. All components of building automation systems.
  - d. Identify reverse acting thermostats as 'COOLING CONTROL'.

- e. Identify hood fire suppression system manual release as 'HOOD FIRE SUPPRESSION SYSTEM MANUAL RELEASE'.
  - f. Identify the filter in the dryer exhaust ductwork as 'CLEAN AFTER EACH DRYING CYCLE'.
  - g. Identify access doors in kitchen hood exhaust ductwork as 'ACCESS PANEL - DO NOT OBSTRUCT'.
  - h. Provide additional miscellaneous identification labels as described on the drawings or in other divisions and sections of the specification.
- .5 Verify all identification labels / tags on site with the Owner / Consultant prior to installation and adjust as directed.

#### 1.25 Cutting, Patching and Refinishing

- .1 Provide cutting and patching of building assemblies to support own project work. Cutting and patching shall be performed by workers specialized in this type of work and capable of performing to good commercial standards. All work shall be to the approval of the Architect / General Contractor.
- .2 No cutting of the building envelope or structural elements shall be done without permission of the Architect.
- .3 This Trade shall patch new openings in building assemblies and openings caused by the removal of existing work. Patching shall be done to maintain existing fire separations, sound transmission class ratings, vapour retarder performance, insulation values, etc. Patching of exterior wall openings shall include filling voids and annular spaces with Roxul (not pink) batt insulation and providing a watertight seal on both sides.
- .4 Finishes damaged by cutting and patching by this Trade shall be made good by this Trade with materials and colours to match existing unless noted on the architectural drawings to be refinished by the General Contractor.
- .5 Conduct a photo survey of existing conditions both inside and outside the building, including of the ceiling immediately below renovation work. Immediately notify the Architect / General Contractor if any resemblance of water leakage or damage is found.
- .6 Protect the existing roofing system from damage at all times. Provide plywood work platforms / walkways as required.
- .7 Where wall openings caused by the removal of thermostats, sensors, etc. are not covered by new wall finishes (refer to architectural drawings) or new thermostats, sensors, etc., provide stainless steel coverplates.
- .8 This Trade shall provide acoustic ceiling tiles matching existing to replace openings caused by the removal of diffusers, grilles, etc.
- .9 This Trade shall remove and reinstall existing acoustic ceiling tiles and grid, lights, etc. as required to suit own project work. Repair or replace materials damaged by this work with materials matching existing.

#### 1.26 Cleaning

- .1 New or affected equipment, fixtures, ductwork, piping, building finishes, building contents, etc. soiled by this Trade's work shall be cleaned to the satisfaction of the Consultant at job completion.
- .2 At the completion of each day's work and at project completion, remove from the area of work all dirt, rubbish, surplus material and equipment associated with this Trade's systems installation and not required in the finished work.
- .3 At project completion, replace all new / existing air filters which have been soiled by the work.

#### 1.27 Existing Construction

- .1 This Trade shall provide adequate protection to existing systems (all disciplines), pavement, curbs, walkways, sodding, shrubs, building construction, building contents, etc. throughout the project. This Trade shall be responsible for restoring to its original condition or replacing any removed or damaged item in connection with the work unless otherwise directed by the Consultant.
- .2 Undertake all necessary measures required by this Trade's work to maintain adequate security of the existing building at all times.
- .3 Any interruption of this Trades services to any part of the existing buildings shall come at a time agreeable to the Owner and Consultant.
  - a. For interruption of sprinkler / standpipe system(s), also notify / obtain the approval of the local Fire Department and Owner's Underwriter.

#### 1.28 Protection

- .1 Where foreseeable damage of any description could result from this Trade's work, this Trade shall provide adequate protection of work previously completed, including work of others. This Trade will be responsible for restoring any damaged materials.

#### 1.29 Demolition

- .1 This Trade shall be responsible for revisions to and for the complete removal of this Trade's systems to permit the new work, all as shown on the drawings or described in the specification. This includes removal of materials from the site. All disposal costs shall be included in the bid price.
- .2 Materials being removed shall become the property of the Owner unless shown otherwise, and if the Owner has no use for it, it shall be disposed of by this Trade. This Trade shall include in the bid price for the disposal of all materials. Note that the Owner shall have the first right of refusal for all demolished equipment.
- .3 Demolished materials shall not be reused unless noted otherwise.

- .4 Where refrigeration systems are noted to be demolished / altered, refrigerant shall be reclaimed and disposed of (where applicable) according to Ministry of Environment and any other authorities having jurisdiction.

### 1.30 Asbestos

- .1 Areas of work are expected to contain asbestos containing materials (ACM). Refer to asbestos audit and section 01 35 43 "Hazardous Materials" for appropriate protocols that must be followed regardless of whether abatement operations are being conducted or not.
- .2 Include the cost of retaining an Owner-approved Sub-trade for the abatement of all asbestos containing materials (ACM) within 24" (600mm) radius of any mechanical work. Refer to the Owner's Hazardous Materials Building Survey.

### 1.31 Sleeves

- .1 Provide sleeves for piping and ductwork as follows:
- a. For all pipe and ductwork penetrations of concrete structures. Pipe sleeves are not required where piping penetrates concrete structures provided all openings comply with the firestop manufacturer's requirements (where applicable).
  - b. For all copper pipe penetrations of masonry, poured concrete and precast structures where required to prevent direct contact of the structure with the copper piping. Sleeves are not required provided that direct contact of the structure is prevented and provided the openings comply with the firestop manufacturer's requirements (where applicable).
  - c. Where required for proper installation of pipe firestop systems.
  - d. Where required for proper installation of fire dampers.
- .2 Pipe sleeves shall be as follows (Trade to choose desired type):
- a. Schedule 40 steel.
  - b. Minimum 24 gauge galvanized steel with an integral flange to secure the sleeve to the formwork.
  - c. Where permitted by the local authority, factory fabricated, flanged, high density polyethylene with reinforced nail bosses.
- .3 Ductwork sleeves shall be manufactured of galvanized sheet steel of at least the same gauge as ductwork penetrating wall and shall be reinforced so as not to be deformed by the placement of the concrete.
- .4 Floor sleeves shall have a minimum 0.5" (13mm) lip on the upper side. All other sleeves shall be flush with adjacent surfaces.
- .5 Unless otherwise directed, all sleeves and openings shall provide minimum 0.25" (6 mm) clear space to ductwork, pipe or insulation. Provide space for application of firestopping for all sleeves and openings according to the fire stop manufacturer's detailed installation drawings. For sleeves used with fire dampers, comply also with the fire damper manufacturer's requirements.

- .6 Provide waterproof, fire retardant, non-hardening caulking between sleeves and building construction where required for a weathertight installation.

### 1.32 Firestopping

- .1 Firestopping shall be 3M or approved equal fire stop sealant / devices, listed in the UL fire Resistance Directory under categories XHCR (firestop devices) and XHEZ (firestop systems) and of a type to suit construction type, penetrant type, annular space requirements and fire rating involved in each separate instance. Systems shall be symmetrical for wall applications and shall be asbestos free. Install according to manufacturer's detailed installation instructions.
- .2 Modify firestop materials where required to be of the same manufacturer as that used by the General Contractor. Coordinate on site.
- .3 Firestop systems shall comply with the required F, T and L ratings, as determined per ASTM E814 / ASTM E119 (as applicable). F ratings shall meet or exceed the fire-resistance ratings of the construction assembly. Firestop systems shall have the required flame spread and smoke developed ratings to suit the point of application and to comply with Code requirements.
- .4 Provide components that are needed for fill materials and to comply with the manufacturer's detailed installation instructions. Use components specified by the manufacturer and approved by the qualified testing and inspection agency, including slag / rock-wool-fiber insulation, forming / damming / backing materials, fillers for sealants, substrate primers, collars / steel sleeves, etc.
- .5 For firestop systems exposed to view, traffic, moisture and physical damage, provide products that after curing do not deteriorate when exposed to these conditions.
- .6 Firestop systems shall be installed by an experienced installer who
  - a. Is qualified by having the necessary experience, staff and training to install the manufacturer's products.
  - b. Is acceptable to or licensed by the manufacturer or local authority.
  - c. Has established a record of successful in-service experience with firestop systems or completed a manufacturer's certified product installation training course.
- .7 Deliver firestop system products to site in original, unopened containers or packages with intact and legible manufacturer's labels identifying product and manufacturer, date of manufacture, lot number, shelf life, qualified testing and inspection agency's classification marking, curing time and mixing instructions. Store and handle materials to prevent their deterioration or damage due to moisture, temperature changes, contaminants or other causes. Follow manufacturer's instructions.
- .8 Verify the condition of the substrates and correct unsatisfactory conditions before installing firestop system products. Follow manufacturer's detailed installation instructions and comply with requirements for temperature and humidity conditions. Coordinate construction and sizing of sleeves, openings and penetrating items to ensure compliance with installation instructions.

- .9 Upon project completion, the firestop manufacturer shall provide a letter certifying that all fire stop systems throughout the project have been installed according to their detailed installation instructions and Code requirements.

#### 1.33 Sound Packing

- .1 Where pipes and ductwork pass through non-rated walls, pack around ductwork or pipe with mineral wool filler to reduce noise transmission.

#### 1.34 Adhesives, Mastics and Sealants

- .1 Adhesives, mastics and sealants as manufactured by Childers, Bakelite, 3M or equal and shall be recommended by the manufacturer for specific application. Application shall be in accordance with manufacturer's recommendations. All materials shall meet flame and smoke developed ratings listed above.

#### 1.35 Cements and Primers

- .1 All cements, primers, etc. shall be low volatile organic compound type, tested to meet the requirements of SCAQMD rule 1168, Test Method #316A (South Coast Air Quality Management District).

#### 1.36 Pipe Escutcheons

- .1 Provide proper chrome plated steel escutcheon plates for exposed uninsulated piping penetrating walls / floors / ceilings except where openings around piping have been filled to the approval of the Consultant.
- .2 Pipe escutcheons shall be one-piece type with set screws for installation at plumbing fixtures.
- .3 Unless noted otherwise, use chrome plated slit type with substantial hinges, positive latches and set screws. Size plates so that they are tight against the wall, floor or ceiling surface concerned; outside diameter to cover opening or sleeve and inside size to fit around finished pipe.

#### 1.37 Access Doors for Walls and Ceilings

- .1 Provide to the General Contractor for installation access doors of sizes as recommended by the manufacturer for all concealed mechanical equipment / components requiring accessibility for service and maintenance. These items should be grouped wherever possible in order to reduce the number of panels required.
- .2 All doors shall be a minimum size of 8" x 8" (200 x 200mm) and a minimum size of 24" x 18" (600 x 450mm) where head and shoulders access is required unless otherwise noted. The exact size of all access doors shall be as recommended by the manufacturer to suit the application.
- .3 Doors shall be manufactured by Acudor Acorn or equal and shall be of the following types (Contractor to choose applicable type):

- a. Drywall & Block: UF-5000, prime coated steel, flush style door with wall frame and screwdriver operated cam lock.
- b. Ceramic Tile and Shower / Washroom / Locker Room Areas: UF-5000-SS,#4 satin polish stainless steel door with wall frame and screwdriver operated cam lock.
- c. Fire Rated Partitions: FB-5060, prime coated steel fire rated door, ULC-2.0 hour 'B' label with self closing key operated locking door.

### 1.38 Dissimilar Metals

- .1 Separate dissimilar metals by means of gaskets or shims of approved material in order to prevent electrolytic action. Where piping of dissimilar metals is connected, use approved dielectric unions or flanges. A brass fitting or brass valve may also be used in making connections between copper and steel piping.
- .2 Where supporting copper pipe, isolate pipe from hanger with electrolytic action tape or equivalent or use copper / plastic coated supports. Direct contact between copper piping and concrete, masonry or precast construction will not be permitted.
- .3 Where installing uninsulated copper pipe for plumbing fixture rough-ins within masonry walls, provide electrolytic action tape or equivalent to prevent contact with concrete / masonry construction. Direct contact between copper piping and concrete, masonry or precast construction will not be permitted.

### 1.39 Installation Requirements

- .1 Install equipment and services as follows:
  - a. Neatly following building lines and in such a manner as to permit free use of space and maximum headroom.
  - b. To allow free access for maintenance, adjustment and eventual replacement.
  - c. In accordance with the manufacturer's requirements.
  - d. Provide all supports, hangers and fasteners except as otherwise noted.
  - e. Do not support piping or ductwork from equipment.
  - f. Secure all products and services so as not to impose undue stresses on the structure or systems.
  - g. Cap off and seal all open ends of new / affected ductwork, venting, piping and conduits to prevent entrance of foreign matter.
  - h. Do not install piping in a location or manner which might result in freezing.
  - i. Layout and install piping, valves, fittings, cleanouts, etc. in conveniently accessible spaces to facilitate easy maintenance.
  - j. All exposed ductwork and piping shall present a neat appearance and located parallel to and centered between building structure, lights, etc.
  - k. Support of ductwork, piping, equipment, etc. from the metal roof / floor deck will not be permitted except as otherwise noted.
  - l. Confirm the exact location of equipment connections, including equipment supplied under other Divisions. Adjust Work as required without extra cost.
  - m. Install metering and / or sensing devices to provide accurate and reliable sampling of quantities being measured. Install instruments to permit easy observation.
  - n. Provide suitable shielding and physical protection for all devices.
  - o. Do not use explosive activated tools.

- p. Neatly install pipes and ducts which are to be concealed close to building structure so that the necessary furring can be kept as small as possible / suspended ceilings installed as high as possible. Special care shall be taken in the installation of the Work to see that it comes within the limits established by the finishes lines of all walls, floors, ceilings, etc.
- q. Provide all sleeves for piping and ductwork.
- r. Supply and locate in place all roof curbs and sleepers required for mechanical equipment.
- s. Failure to comply with these requirements will render the Contractor responsible for the cost of all extra Work hereby required.

#### 1.40 Superintendence

- .1 Maintain at the job site at all times qualified personnel and supervisory staff with proven experience in construction, managing, testing and commissioning projects of comparable size, nature and complexity. Any individual deemed to be unsatisfactory by the Consultant shall be replaced.
- .2 Provide full time supervision and inspection of the Work and be responsible for quality control.

#### 1.41 Product Delivery and Installation

- .1 Receive, unload, inspect, store and install all Products according to manufacturers recommendations and as herein specified.
- .2 Handle equipment carefully to prevent damage, breaking, denting and scoring. Damaged units or damaged components shall not be installed. Replace damaged parts with new supplied by the manufacturer.
- .3 If equipment is to be stored prior to installation, store in a clean, dry place. Protect from weather, dirt, fumes, water, physical damage, etc.
- .4 Cover Products and take special precautions to prevent damage and entry of foreign material into any working parts and into piping or ductwork.
- .5 Comply with the manufacturer's rigging and installation instructions for unloading and moving into final location.
- .6 Level equipment according to manufacturer's requirements, and to permit proper condensate drainage where applicable.
- .7 Assemble, install and start-up equipment according to manufacturer's requirements. Complete all manufacturer start-up literature (where applicable) and include in the Operation and Maintenance Manual.
- .8 Provide adequate / manufacturer's required / Code required clearances to permit servicing and maintenance of equipment.

#### 1.42 Start-up

- .1 The Mechanical Contractor shall be responsible for adjusting, testing and start-up of all mechanical equipment supplied and / or installed under this contract.
- .2 Before starting any mechanical systems, the following conditions shall be met:
  - a. Safety controls are installed and fully operational.
  - b. Qualified personnel employed by this Division are available and will operate the equipment and systems.
  - c. Air filters have been installed / cleaned.
  - d. Mechanical equipment rooms are broom clean.
  - e. Air supply and return ducts, equipment and plenums are clean.
  - f. Motor starters have been checked for correct size of thermal overload.
  - g. Control systems including thermostats have been tested for sequence of operation.
  - h. Fans have been checked for operation and rotation and have been adjusted.
  - i. Fluid systems have been flushed, cleaned and chemically treated.
  - j. Fire dampers and combination fire / smoke dampers are in the open position.
  - k. Duct access doors are in place.
  - l. Pipe and duct insulation has been installed.
  - m. Systems subject to freezing conditions have been protected.
  - n. Lubricate all bearings.
  - o. Adjust and set all 'V' belt drives and drivers for proper alignment and tension.
  - p. Operate and test all motors and speed switches for correct wiring sequences.
  - q. Replace and clean all strainers.
  - r. Fasten all loose and rattling pieces of equipment.
- .3 Follow start-up procedures as recommended by the manufacturer. Additional special start-up procedures may be specified elsewhere in this specification. Complete manufacturers start-up sheets (where available).
- .4 The Contractor shall be responsible for all equipment during the start-up period and shall be responsible for any damage caused to equipment, personnel and building components and shall accept all liability for repairs and / or replacement at no cost to the Owner.

#### 1.43 Manufacturer Certification

- .1 Where directed by the Consultant, submit letters from the manufacturers of all equipment certifying that their technical representatives have inspected and tested their equipment and are satisfied with the methods of installation and operation. When existing systems are affected, provide letters covering both new and existing equipment and connections.
- .2 These letters shall state the names of persons present at testing, methods used, a list of functions performed and a list of equipment tested.

#### 1.44 Equipment Supports

- .1 Provide structural steel supports, braces, tie rods, etc. required to support and hang all mechanical equipment, ductwork, piping, etc. installed under the Mechanical contract. Structural roof support for roof mounted equipment / mechanical systems penetrating the roof deck shall be according to structural drawings / specifications.

- .2 Where structural bearings do not exist suspend hangers from steel channels or angles. Provide supplementary structural members.
- .3 Obtain approval before using vertical expansion shields. Use minimum two shields for each hanger.
- .4 Do not suspend piping, ductwork or equipment from the metal roof / floor deck unless noted otherwise.
- .5 Supports not supplied by equipment manufacturer shall be fabricated from structural steel meeting the requirements of the structural drawings / specifications. Support sizing shall be by the Mechanical Contractor except that where directed by the Consultant, sizes shall be confirmed by the Structural Engineer (at no cost to the Contractor) and adjusted by the Contractor without extra cost.

#### 1.45 Use of System for Construction

- .1 The new or existing mechanical system(s) or any part thereof shall not be used during construction for construction purposes.
- .2 Provide temporary heat for the building where required during the complete construction process.

#### 1.46 Flashings

- .1 Unless noted below, all flashings and counter flashings required for this Trade's work shall be supplied and installed by the General Contractor.
- .2 If piping and wiring is not indicated on drawings to penetrate roof assembly through a doghouse, it shall penetrate through the following roof flashing system:
  - a. Portals Plus extra tall Aluma-Flash complete with 0.60" aluminum base, 13" high and 14" diameter. 8" collar opening shall have two sealing rings to suit EPDM cap of type to suit services. All services to be secured to cap with stainless steel clamps.
  - b. Roof flashing system to be supplied by this Trade and installed by the General Contractor.

#### 1.47 Paint

- .1 Provide paint for patching of existing / damaged finishes.
- .2 Provide Painting and finishing for work under this Division unless otherwise noted, including painting of all exposed ductwork, uninsulated piping, convectors, cabinet heaters, etc. according to Division 9.
- .3 Provide painting of gas piping to meet Code requirements.
- .4 If not factory coated, clean, wire brush and paint all ferrous supports and hangers concealed in ceiling spaces of kitchens, laundry rooms and other high humidity areas. Alternatively, galvanized supports and hangers may be used in these areas.

- .5 Repaint or refinish all damaged factory applied finishes to equipment.
- .6 All primers and paints shall be good quality commercial grade (Para or equal) to suit the application. Paint used outdoors shall be suitable for exterior use. Apply according to manufacturers recommendations. All painted surfaces shall have a minimum of one primer coat and two finish coats.

#### 1.48 Field Review

- .1 The Owner and Consultant shall have access to the site at all times for review of the Work during construction.
- .2 Correct any deficiencies as they are reported during the performance of the Work.
- .3 Final review shall be done when:
  - a. All reported deficiencies have been corrected.
  - b. All systems have been balanced, tested, commissioned and are operational.
  - c. The Owner has been instructed in the operation and maintenance of all equipment.
  - d. The balancing report has been submitted and reviewed.
  - e. The operating and maintenance manual(s) have been submitted and reviewed.
  - f. All tags, nameplates and identification labels are in place.
  - g. All mechanical systems have been cleaned to the satisfaction of the Consultant.
  - h. All certificates of approval provided by the local authorities have been submitted.
  - i. All specified spare parts and replacement parts have been provided.
  - j. All as-built drawings have been submitted and reviewed.

#### 1.49 Inspection Certification

- .1 Arrange for inspection of all work by the authorities having jurisdiction. Obtain unconditional certificates of approval, acceptance and compliance with rules and regulations for authorities having jurisdiction. The work will not be considered complete until such certificates have been delivered to the Owner.
- .2 Attend promptly to any deficiencies reported. Request final review when the completed installation has been checked and all deficiencies have been rectified.

#### 1.50 Testing, Cleaning and Flushing Systems

- .1 Testing
  - a. Furnish all labour, materials, instruments, etc. necessary for all required tests.
  - b. All work shall be subject to inspection by the local building department inspectors and / or the Consultant. Provide a letter of certification when all pressure tests have been carried out in accordance with specifications, applicable codes and authorities having jurisdiction.
  - c. Do not insulate or conceal any piping / ductwork until testing is complete and systems have been approved. Before testing any piping, isolate all equipment which has an insufficient rating compared with the test pressure.

- d. Repair all leaks to the inspection authority and / or the Consultant's approval. All leaks shall be repaired by remaking the joint.
  - e. Test hot water heating system piping at 1.5 times the system operating pressure or 125 Psig (860 Kpa), whichever is greater for a minimum 4 hour period.
  - f. Test domestic water (hot, cold and recirc), sanitary and vent piping according to Plumbing Code requirements and to the requirements of the local plumbing authority.
  - g. Test natural gas systems in accordance with Gas Code requirements.
  - h. Test fire protection systems in accordance with NFPA, local authorities and Owner's Underwriters requirements. All site service water piping shall be tested by the Site Service Contractor.
  - i. After piping systems have been tested and repaired, repeat tests.
  - j. Correct any cases of excessive surge pressure ('water hammer').
  - k. Test all new plumbing fixtures / trim for soundness, stability of support and correct operation.
- .2 Cleaning and Flushing
- a. Refer to Divisions 22 and 23 for cleaning and flushing of piping systems.

#### 1.51 Testing, Adjusting and Balancing

- .1 Retain the services of an independent Balancing Trade to test, adjust and balance the systems and include for the provision of a balancing report. All work shall be performed in compliance to the requirements of the National Environmental Balancing Bureau (NEBB) or Associated Air Balance Council (AABC) and the Balancing Trade shall be certified with one of these agencies.
- .2 The following is a list of the approved Balancing Trades whom may quote on the balancing of the systems:
  - a. Air Audit Inc., 110 Turnbull Court, Cambridge, Ontario, N1R 1K2, (519) 740-0871
  - b. Clark Balancing Ltd., 8094 Esquesing Line, Milton, Ontario, L9T 2X9, (905) 693-1518
  - c. Airwaso Canada Inc., 124-4096 Meadowbrook Drive, London, Ontario, N6L 1G4, (519) 652-4040
  - d. Dynamic Flow Balancing Ltd., 1200 Speers Road, Unit 36, Oakville, Ontario, L6L 2X4, (905) 338-0808
  - e. Air Velocities, 100 Premium Way, Mississauga, Ontario, L5B 1A2, (905) 279-4433
  - f. Flowset Balancing Ltd., 431 Willis Drive, Oakville, Ontario, L6L 4V6, (416) 410-9793
- .3 Provide all necessary precision instruments, pressure gauges, manometers, thermometers, etc. for measuring and adjusting. Use instruments which are of correct scale and accurately calibrated.
- .4 All balancing shall be done in a manner to minimize throttling losses and using speed adjustment to meet design flowrates. Final flowrates shall be within ten percent (10%) of specified value.
- .5 Start balancing only when the work is essentially completed, including: installation of ceilings, doors, windows and other construction affecting testing and balancing; application of sealing, caulking and weatherstripping; normal operation of mechanical / electrical / control systems

affecting testing and balancing; thermal overload protection in place for electrical equipment; air filters clean and in place; ductwork systems clean of debris; correct fan rotation; fire and volume dampers in place and open; coil fins cleaned; all ductwork outlets installed and connected; access doors closed; ductwork installation complete; water systems flushed, filled and vented; correct pump rotation; proper strainer baskets clean and in place; service and balancing valves fully open; liquid treatment system operable.

- .6 The Balancing Trade shall perform the following work in regards to air systems:
- a. Test and adjust system / equipment for design air flows.
  - b. Equipment requiring air balancing shall be as follows:
    - i. Fans having capacities greater than 150 cfm (70 l/s).
    - ii. Rooftop units, including minimum outdoor air adjustment.
    - iii. Rooftop energy recovery ventilator.
  - c. Locations of systems measurements / adjustments shall include but not be limited to the following as appropriate:
    - i. Each duct run-out (or grille / diffuser) having an indicated airflow on the drawings.
    - ii. Each VVT system damper (zone and by-pass).
    - iii. Make pitot tube traverse of main supply / return / exhaust duct to verify design airflows at equipment.
  - d. Measurements shall include but not be limited to the following as appropriate for systems / equipment / controls:
    - i. Air velocity, flow rate, static pressures (including suction and discharge), ductwork cross-sectional area, RPM, electrical power (including full load amperes), voltage, sheave diameter / setting, belt quantity / size.
  - e. Test and adjust blower RPM to design requirements. All required pulleys shall be supplied / installed / adjusted by the Balancing Trade.
  - f. Adjust grilles and diffusers to obtain optimum air distribution patterns. Also adjust to suit the Consultant.
  - g. Verify control system operation and report on any installation problems observed, including excessive duct pressures when VVT systems are operating in by-pass mode. Physical changes in the control system, such as relocating sensors or calibrating controllers, are the responsibility of the Mechanical Trade. The Balancing Trade shall work closely with Mechanical Trade to identify and correct problems.
  - h. For VVT systems, perform the following to ensure excessive noise is not generated:
    - i. For each VVT system, the Balancing Trade shall measure the static pressure in the main ductwork at the location of the by-pass damper using a manometer when the system is in fixed mode (all zone dampers are full open and the by-pass damper is full closed). This information shall be included in the TAB Report and shall be given to the Mechanical Trade for verification that the VVT system is properly calibrated.
    - ii. For each VVT system, 10% of the dampers shall be set to the full open position and 90% shall be set at their minimum position. When operating with these damper positions, the static pressure in the main ductwork at the location of the by-pass damper shall again be measured by the Balancing Trade using a manometer to ensure it remains at the value measured when in the fixed mode. This information shall be included in the TAB Report and shall be given to the Mechanical Trade for verification that the VVT system is operating correctly and is properly calibrated.

- iii. During balancing procedures, set controls to a fixed mode (by-pass damper locked fully closed and all zone dampers locked fully open) to prevent any changes during the balancing procedure. In the fixed mode, only the system manual balancing dampers shall be used to achieve the indicated balancing airflows.
- .7 The Balancing Trade shall perform the following work in regards to water systems:
- a. Test and adjust system / equipment for design water flows.
  - b. Equipment requiring water balancing shall be as follows:
    - i. Each convector / cabinet heater / unit heater.
  - c. Locations of systems measurements / adjustments shall include but not be limited to the following as appropriate:
    - i. Each circuit balancing valve.
    - ii. Balancing of the water flow through each loop of the in-floor snow melting / radiant heating piping will not be required (water flows through this piping will be adjusted by the Plumbing Trade).
  - d. Measurements to include but not limited to the following as appropriate for systems, equipment, components, controls:
    - i. Flow rate, head pressure / pressure drop, temperature, RPM, electrical power (including full load amperes), voltage.
  - e. Measure the water temperature difference across the heat exchanger when pumps are operating at design flow rates and the system is operating at design temperatures.
  - f. Fluid flow quantities shall be measured using the installed devices provided by Others.
  - g. The Balancing Trade shall not continue the water balancing if at any time hazardous conditions are observed. These conditions shall be reported before proceeding further.
  - h. The Balancing Trade shall apply any necessary correction factors to the indicated values to account for the density of the fluid flowing in the system.
  - i. If specified, pitot tube traverse shall be taken where required on the drawings, provided valved openings are properly installed.
  - j. Where circuit balancing valves are not installed or do not provide accurate flow indication, measure pump capacities by differential pressure measurements, amperage and brake horsepower method using the pump manufacturer's capacity curve.
  - k. Position all automatic control valves and balancing / isolation for full flow through equipment during initial pump adjustment.
- .8 Upon balancing completion, the Balancing Trade shall submit the final system balancing report (TAB Report) to the Mechanical Trade for inclusion in the Operation and Maintenance Manual. One paper hard copy and one .PDF electronic copy is required. Report shall include index page, index tabs and shall be certified by the Balancing Trade. Handwritten data will not be accepted. Include types, size, manufacturer, serial numbers and dates of calibration of all instruments used. The format shall be in accordance with the Canadian AABC or NEBB Report Form and approved by the Consultant. In addition, the report shall include:
- a. Project record drawings.
  - b. System schematics.

- c. All measured / adjusted values (include initial and final readings).
  - d. All pertinent information regarding balanced equipment shall be listed, such as:
    - i. Designation of equipment.
    - ii. Manufacturer.
    - iii. Type.
    - iv. Size.
    - v. Motor nameplate characteristics.
- .9 During the system testing, adjusting and balancing, the Mechanical Trade shall fully demonstrate the operation of all controls. The Mechanical Trade shall be present during the testing, adjusting and balancing and make modifications as often as necessary to satisfy the Balancing Trade.

#### 1.52 Commissioning

- .1 The commissioning function involves:
- a. Activation of all systems.
  - b. Calibration, testing and verification of all systems.
  - c. Demonstration and instruction to Owner's staff.
- .2 Be responsible for commissioning of all work provided under this division and as further defined in this section.
- .3 Supply the services of a trained specialist to thoroughly explain each mechanical system, its operation and its maintenance to the full satisfaction of the Consultant and Owner. Allow for one technician to spend one day for training for each system unless more time is indicated in the specifications for a particular system.
- .4 Where requested by the Consultant, provide acceptance tests to demonstrate that the equipment and systems meet the specified requirements. Tests may be conducted as soon as conditions permit. Make all changes, adjustments or replacements required as the preliminary tests may indicate prior to final tests.
- .5 All commissioning shall be video recorded by the Mechanical Contractor. Submit video thumb drive with close out documentation.

#### 1.53 Substantial Performance Certificate

- .1 Before the Contractor can make application for a Certificate of Substantial Performance the Mechanical Trade will be required to provide the following as detailed within this section:
- a. Operating and maintenance manuals.
  - b. As-Built drawings.
  - c. Testing, adjusting and balancing.
  - d. Commissioning.
  - e. Training and Demonstrations.
  - f. All certificates of approval provided by the local authorities have been submitted.
  - g. Warranty cards.

### 1.54 Discount Pricing

- .1 The Waterloo Region District School Board receives discount pricing from Noble Trade. This Trade is encouraged to contact Noble Trade for pricing on this project.

### 1.55 Warranty

- .1 This Trade shall furnish a written guarantee stating that all work executed under this contract will be free from defects of workmanship and materials for a period of two (2) year from the date of Ready-for-Takeover or as further defined in Division 1. The period shall in no way supplement any other warranty of a longer period.
- .2 Warranty shall commence at the date for Ready-for-Takeover and not from the date the products put into operation.
- .3 This Trade will at their own expense, repair and replace all such defective work and other work damaged thereby which fails or becomes defective during the term of the warranty provided that such failure is not caused by improper use.
- .4 Repair all defects in a manner to prevent recurrence.
- .5 Refer to the Division 01 specifications for additional warranty details.
- .6 Include for completion of the WRDSB Project Warranty Card prior to Substantial Performance.

## **2. THERMAL INSULATION**

### 2.1 General

- .1 Work of this Section generally consists of the following:
  - a. All labour, materials, equipment, specialties, etc. required to furnish and completely install in a first class condition the following mechanical insulation systems:
    - i. Plumbing:
      - 1) piping
      - 2) equipment
    - ii. HVAC:
      - 1) piping (hot water heating / heat pump systems only.
      - 2) equipment
      - 3) ductwork (thermal insulation only. All acoustic insulation shall be supplied and installed by Division 23.)
      - 4) humidifier steam, condensate and drain piping
- .2 Submittals
  - a. Not required for this Section.
- .3 Quality Assurance

- 
- a. All insulation shall be applied in general accordance with TIAC National Insulation Standards Manual, manufacturer's published instructions and requirements, and these specifications.
  - b. Work shall be carried out by a qualified Insulation Trade with an established reputation for this type of work.
- .4 All insulation and components shall have maximum flame and smoke spread ratings of 25 and 50, respectively.
- .5 General Installation Requirements:
- a. Apply covering in a neat workmanlike manner so that finished job is uniform and smooth in finish.
  - b. Ensure that all piping (including valves and fittings), ductwork and equipment are dry and clean before applying covering.
  - c. Do not apply insulation until the items to be covered have been tested against leakage.
  - d. Butt joints firmly together. Stagger joints in multiple layer construction. All joints shall be taped unless noted otherwise.
  - e. Locate longitudinal seams so as to be invisible.
  - f. Cover all joints with self-sealing 3" (75mm) wide butt strips provided by the insulation manufacturer or vapour barrier tape.
  - g. Install pipe insulation continuous through barriers (walls, ceilings, floors, etc.).
  - h. Install duct insulation continuous through barriers (walls, ceilings, floors, etc.) except at fire dampers.
  - i. For domestic cold water (potable and non-potable) piping as well as for all duct thermal insulation, maintain integrity of vapour barrier jacket over all insulation, taking special precaution at fittings, valves, strainers, etc. For these systems:
    - i. Install insulation directly over pipes and not over hangers, supports, etc.
    - ii. Protect pipe insulation with metal shields at all supports where such piping is 1.5" (38mm) NPS and larger. Shields shall be as follows:
      - 1) Shields shall be formed to fit the insulation and shall extend up to the centerline of the pipe. They shall be of the length specified for the insulation hanger inserts less 4" (100mm) to allow for vapour retarding butt joints on each side of the shields.
      - 2) Shield gauges shall be as follows:
        - I 1.5" (38mm) to 3" (75mm) pipe: 20 gauge
      - 3) Shield widths shall be as follows:
        - I 5" (125mm) pipe and smaller pipe: 4" (100mm)
        - II 6" (150mm) and over pipe: 7" (175mm)
      - 4) Ensure duct and pipe insulation is not broken at supports, hangers and standing duct seams. Where required, provide vapour barrier tape to maintain the integrity of the vapour barrier jacket at these locations.
    - iii. Finish insulation ends with self-sealing 3" (75mm) wide butt strips provided by the insulation manufacturer or vapour barrier tape.
  - j. Protect insulation as follows:
    - i. Protect insulation passing through floors, walls and similar barriers to prevent damage.

- ii. Provide high density insulation inserts at all supports where insulation is protected by metal shields as follows (Trade to choose desired type):
  - 1) Johns Manville Thermo-12 Gold or approved equal calcium silicate, rigid, sectional pipe and block type.
  - 2) Koolphen K-block having a density to suit load, complete with vapour barrier all service jacket and factory applied metal shield.
  - 3) Insulation thickness shall match that of the adjacent insulation.
  - 4) Insert lengths shall be as follows:
    - I 1.5" to 2.5" (38 to 63mm) pipe size: 10" (250mm) long
  - 5) For cold water (potable and non-potable.), inserts shall be provided with vapour retarder seals and / or coatings.
  - 6) Install inserts as follows:
    - I Install the high density insulation before installing the pipe insulation.
    - II Install the pipe insulation.
    - III Install the finish jacket where specified elsewhere.
    - IV Install a metal shield over the insulation / finish jacket.
- iii. Provide expansion and contraction joints in piping insulation for adequate movement without damage to insulation or finishes. Terminate single layer and each layer of multiple layer in straight cut at intervals recommended by manufacturer. Leave void of 1" (25mm) between terminations and pack with light density Fiberglas AF-300 Type 1.
- k. Install insulation over equipment which may require service or replacement by maintenance staff (valves, strainers, unions, flanges, etc.) to be easily removable or replaceable without damage to adjacent insulation (use only pre-fabricated type insulation).
- l. Valves, strainers, unions, flanges, etc. which are 1" (25mm) and smaller in domestic water systems (potable and non-potable), and heating water systems are not required to be insulated. All valves on chilled water systems, or systems which operate at a temperature lower than 65°F (18°C), shall be insulated.
- m. Existing pipe and duct insulation shall remain unchanged except that all existing insulation affected during installation of new work shall be repaired.
- n. Where asbestos insulation has been removed, provide new fiberglass insulation.

## 2.2 Pipe Insulation

- .1 Rigid Piping: Johns Manville Micro-Lok or approved equal, pre-moulded, glass fibre, rigid, sectional sleeve insulation with a K factor of 0.23 Btu-in/hr-ft<sup>2</sup>-°F (0.033 W/m-°C) at a mean temperature of 75°F (24°C) and jacketed with a factory applied reinforced vapour retarder facing having a longitudinal acrylic adhesive closure system. Thickness and application shall be as specified below.
- .2 Valves and Fittings: Pre-formed fittings or mitred segments to match adjacent pipe insulation. Where insulation is to be provided with PVC covers, insulation may be revised to Johns Manville Microlite Standard Type 150 or approved equal formaldehyde-free, flexible glass fibre, blanket insulation with a K factor of 0.24 Btu-in/hr-ft<sup>2</sup>-°F (0.035 W/m-°C) at a mean temperature of 75°F (24°C) and a factory applied FSK vapour barrier facing having a 2" (50mm) stapling tab.
- .3 Valve Bonnets and Victaulic Fittings:

- 
- a. Preferred Insulation Method:
    - i. Provide over-sized straight run insulation at Victaulic fittings and over-sized T fittings at valve bonnets.
  - b. Alternate Insulation Method:
    - i. This method may be used only where approved by the Consultant and where there is insufficient space for application of insulation according to the preferred method.
    - ii. Provide Armacell AP Armaflex Sheet and Roll or approved equal, closed cell, fibre free, elastomeric foam with a thermal conductivity of 0.25 Btu-in/hr-ft<sup>2</sup>-°F (0.036 W/m-°C) at a mean temperature of 75°F (24°C). Insulation shall be applied according to manufacturer's requirements and as follows:
      - 1) Use full coverage of Armaflex 520 adhesive on both mating surfaces (use low VOC type where specified under General Conditions).
      - 2) Finish insulation with two coats of WB Finish, white water-based latex enamel.
  - c. Insulation thickness shall match that of the adjacent insulation.
- .4 Install rigid fiberglass type insulation according to manufacturer's requirements and as follows:
- a. Apply the SSL II Positive Closure System smoothly and securely as per the manufacturer's requirements, ensuring all contacting surfaces are kept clean.
  - b. Apply insulation on valves, backflow preventers, strainers, unions, flanges, fittings, etc. prior to straight run insulation.
  - c. Insulation on fittings shall be cut in proper segments to provide a tight fit or pre-formed fittings shall be used. Insulation on valves, backflow preventers, strainers, unions, flanges, etc. shall be pre-formed type only.
  - d. All insulation for fittings shall be cut to suit the length of the body plus 2" (50mm) at each end.
  - e. Any void between the insulation on fittings, valves, backflow preventers, strainers, unions, flanges, etc. and the straight run insulation shall be filled with insulation segments cut to fit the gap.
  - f. If a continuous vapour barrier is specified, finish insulation ends with self-sealing 3" (75mm) wide butt strips provided by the insulation manufacturer or vapour barrier tape.
- .5 Finish Covering for Insulation (Interior of Building):
- a. Leave as All Service Jacket (ASJ) or FRK finish except as otherwise noted below.
  - b. All interior exposed pipe insulation shall be provided with PVC jacketing, Proto or approved equal as follows:
    - i. Insulation located within suspended ceiling spaces, cabinet spaces and walls will not be considered exposed.
    - ii. System shall consist of one piece and two piece pre-moulded high impact LoSMOKE PVC pipe and fitting covers with all required accessories, which include elbows, tees, valves, end caps, mechanical line couplings, specialty fittings, tank end panels, tack fasteners, tapes and specialty items. Jacket shall be bright high-gloss white colour.
    - iii. Jacket shall have flame spread rating and smoke developed classification of 25 and 50, respectively.

- 
- iv. Jacket shall not promote the growth of fungi or bacteria.
  - v. Fiberglass insert shall not be provided.
  - vi. Jacket shall be 0.02" (0.5mm) thick with standard one piece fitting cover.
  - vii. Apply according to manufacturer's requirements and as follows:
    - 1) Apply on clean, dry surfaces.
    - 2) Do not apply jacket too tightly. Install slide joints and jacket to prevent cracks and puckering.
    - 3) Jacket shall be cut and rolled to fit the circumference of pipe plus a 2" (50mm) overlap.
    - 4) Apply PVC adhesive bead (Red Devil Inc. Celulon or approved equal, water based, clear) along longitudinal edge, approximately 1" (25mm) in from edge, and apply jacket over adhesive using firm pressure for attachment. Temporarily hold PVC jacket in place using masking tape until firmly attached.
    - 5) Provide PVC end caps at all insulation endpoints (caulked joints will not be permitted).
    - 6) Any corners or cracks shall be neatly finished with a white silicone caulking bead.
    - 7) Secure throats of fitting, valve, etc. covers by either tack fastening or taping (do not use tacks where a vapour barrier insulation system is specified). For insulation systems required to have a vapour barrier insulation, use Proto PVC tape with a minimum 2" (50mm) downward overlap.
    - 8) Where jacket is specified on the drawings to be waterproof, use 0.10" (0.25mm) thick jacket with self-sealing lap tape as the first waterproof layer. Overlap ends 3" (75mm) and provide PVC tape. Caulk all openings with Celulon or approved equal. The second layer shall be 0.10" (0.25mm) thick jacket applied to the standards described above for non-waterproof applications. Install slide joints every 25'-0" (7.5m) and caulk shut all other seams, openings or end overlaps. Position all longitudinal joints to shed water.
  - c. All exposed insulation on fittings, valves, backflow preventers, unions, flanges, etc. shall be covered with white premoulded and prefabricated PVC jacketing. The application shall be according to manufacturer's recommendations and as described above.
- .6 No finish covering shall be applied until the Consultant has inspected the insulation.
- .7 Pipe insulation thicknesses shall be as follows:
- a. Copper Domestic Cold Water (potable and non-potable): 0.5" (13mm).
  - b. Copper Domestic Hot Water (potable and non-potable): 1" (25mm) with the following exception:
    - i. Hot water piping 1.5" (38mm) and larger shall be provided with 1.5" (38mm) insulation.
  - c. Metal and Plastic Heating Water (Supply and Return):
    - i. Heating water piping 1.25" (32mm) and smaller shall be provided with 1.5" (38mm) insulation.
    - ii. Heating water piping 1.5" (38mm) and larger shall be provided with 2" (50mm) insulation.

### 2.3 Duct Insulation (Interior of Building)

- .1 Johns Manville Microlite XG Type 75 or approved equal formaldehyde-free, flexible glass fibre, blanket insulation with a K factor of 0.27 Btu-in/hr-ft<sup>2</sup>-°F (0.039 W/m-°C) at a mean temperature of 75°F (24°C) and a factory applied FSK vapour barrier facing having a 2" (50mm) stapling tab. Provide as follows:
  - a. In concealed locations, where insulation is required on rectangular ductwork as indicated on drawings and as per below. Concealed locations include ceiling spaces (including suspended), bulkheads, walls, attics, etc.
  - b. In exposed locations, where insulation is required on round ductwork as indicated on drawings and as per below. Concealed locations include ceiling spaces (including suspended), bulkheads, cabinet spaces, walls, attics, etc.
  - c. Ductwork shall be provided with 1.5" (38mm) insulation unless otherwise noted.
- .2 Johns Manville 800 Series Spin Glas or approved equal 3.0 lb/ft<sup>3</sup> (48.1 kg/m<sup>3</sup>) density rigid board insulation with a K factor of 0.23 Btu-in/hr-ft<sup>2</sup>-°F (0.035 W/m-°C) at a mean temperature of 75°F (24°C) and a factory applied FSK vapour barrier facing. Provide as follows:
  - a. In exposed locations, where insulation is required on rectangular ductwork as indicated on drawings and as per below. Exposed locations exclude ceiling spaces (including suspended), bulkheads, walls, attics, etc.
  - b. Ductwork shall be provided with 2" (50mm) insulation unless otherwise noted.
- .3 Insulation fasteners shall be 12 gauge (2mm) zinc coated steel pins at 16" (400mm) to 18" (450mm) on center complete with minimum 1.5" (38mm) square plastic or zinc plated steel self-locking washers. Alternatively, use Continental spindle anchors held in place with Tac Two or approved equal adhesive at 16" (400mm) to 18" (450mm) on center.
- .4 Insulation self-adhesive tape shall be MacTac Canada Ltd. or Venture Tape, ULC listed.
- .5 Flexible insulation shall be applied as follows:
  - a. Cut to have a 3" (75mm) minimum overlap.
  - b. On round ductwork, provide one row of welded or glued on spindle anchored pins on top or side section at 12" (300mm) centers (length of pins shall suit ductwork). Proper washers shall be pressed on the pins and the ends of the pins cut before sealing with a piece of 4" (100mm) tape. On round ductwork 14" (350mm) and smaller, 0.5" (13mm) wide 20 gauge stainless steel banding may be used as an alternate to the anchoring pins (install bands at 12" (300mm) on center).
  - c. On rectangular ductwork, apply as specified for round ductwork where dimensions do not exceed 16" (400mm) in total on the four sides. On larger ductwork, the sides and bottom shall have stud welded pins or spindle anchored pins glued on at 16" (400mm) to 18" (450mm) on center.
  - d. All circumferential and longitudinal joints shall be stapled with outward clinching staples and taped with minimum 3" (75mm) wide RFFRK tape. All pin penetrations or punctures in facing shall also be taped. Note: for ducts to be used for heating only, the RFFRK facing can be eliminated.
  - e. All pin penetrations or punctures and all circumferential and longitudinal joints in jacket shall be sealed with a 4" (100mm) vapour barrier tape.

- f. Refer also to manufacturer's requirements.
- .6 Rigid insulation shall be applied as follows:
- a. Cut to fit between standing seams and stiffeners.
  - b. Apply welded or glued on pins installed at maximum 18" (450mm) on center. Apply pins with reduced clearances where necessary to properly secure insulation.
  - c. Apply to top of duct first, with edges of insulation even with edges of ductwork.
  - d. Next apply to sides of duct by cutting board to cover the top edge of insulation and to be even with the bottom edge of the duct.
  - e. Next apply to bottom of duct by cutting board to be even with the outside edges of the side insulation.
  - f. Mechanical washers shall be applied as the board is being installed. Cut the remainder of the unnecessary pins.
  - g. At corner, joints and washers, a 4" (100mm) tape shall be used to seal all joints and maintain integrity of vapour barrier.
  - h. Where elbows occur, slit board at 1" (25mm) centers in a "V" type cut where necessary to soften the board.
  - i. Provide drywall type metal corner beads on edges of insulation, secured in place with tape.
  - j. Insulation shall be wrapped tightly on the ductwork with all circumferential joints butted and longitudinal joints overlapped a minimum of 2" (50 mm). Adhere insulation to duct with 4" (100mm) wide strips of bonding adhesive, at 8" (200mm) o.c. For ducts over 24" (600mm) wide secure insulation to bottom of duct with mechanical fasteners at not more than 18" (450mm) o.c.
  - k. Refer also to manufacturer's requirements.
- .7 All exposed insulation on ductwork shall be covered with PVC jacketing, Proto or approved equal as follows:
- a. System shall consist of one piece and two piece pre-moulded high impact LoSMOKE PVC duct and fitting covers with all required accessories, which include elbows, tees, end caps, specialty fittings, tack fasteners, tapes and specialty items. Jacket shall be bright, high-gloss white colour.
  - b. Jacket shall have flame spread rating and smoke developed classification of 25 and 50, respectively.
  - c. Jacket shall not promote the growth of fungi or bacteria.
  - d. Jacket shall be 0.02" (0.5mm) thick with standard one piece fitting cover.
  - e. Apply according to manufacturer's requirements and as follows:
    - i. Apply on clean, dry surfaces.
    - ii. Do not apply jacket too tightly. Install slide joints and jacket to prevent cracks and puckering.
    - iii. Jacket shall be cut and rolled to fit the circumference of pipe plus a 2" (50mm) overlap.
    - iv. Apply PVC adhesive bead (Red Devil Inc. Celulon or approved equal, water based, clear) along longitudinal edge, approximately 1" (25mm) in from edge, and apply jacket over adhesive using firm pressure for attachment. Temporarily hold PVC jacket in place using masking tape until firmly attached.

- v. Provide PVC end caps at all insulation endpoints (caulked joints will not be permitted).
  - vi. Any corners or cracks shall be neatly finished with a white silicone caulking bead.
  - vii. Secure throats of fitting covers by taping. Use Proto PVC tape or equivalent with a minimum 2" (50mm) downward overlap.
  - viii. Where jacket is specified on the drawings to be waterproof, use 0.10" (0.25mm) thick jacket with self-sealing lap tape as the first waterproof layer. Overlap ends 3" (75mm) and provide PVC tape. Caulk all openings with Celulon or approved equal. The second layer shall be 0.10" (0.25mm) thick jacket applied to the standards described above for non-waterproof applications. Install slide joints every 25'-0" (7.5m) and caulk shut all other seams, openings or end overlaps. Position all longitudinal joints to shed water.
  - f. Fiberglass insert shall not be provided.
  - g. Alternatively, where insulation is exposed on rectangular and round ductwork in all locations, provide canvas covering, S. Fattal Canvas Inc. Thermo-canvas classic or approved equal, ULC listed and labeled, roll form. Apply in a neat way by rolling the canvas around the circumference of the pipe. Hold in place with a lagging adhesive, Bakor 120-18 or equal. Complete the finish using a heavy coat brush and if necessary, or where directed by the Consultant, provide a second coat after 24 hours.
- .8 No finish covering shall be applied until the Consultant has inspected the insulation.
- .9 Insulate strap hangers 4" (100mm) beyond insulated duct.
- .10 Insulation shall be provided as indicated on drawings and as per the following:
- a. Supply ductwork in unconditioned spaces (not air-conditioned) including ceiling spaces (not used as a return air plenum), bulkheads, walls, etc.
  - b. First 8'-0" (2.4m) of exhaust ductwork on interior side of exterior wall, roof, etc. penetrations.
  - c. Intake (outdoor air) ductwork located in interior of building.
  - d. Plenum (intake (outdoor air) and exhaust), including entire wall box, located in interior of building.
  - e. Note, 0.5" acoustic insulation is not a sufficient substitute for required thermal insulation for interior ductwork. For exterior ductwork, both acoustic and thermal insulation are required.

#### 2.4 Fire Rated Duct Insulation

- .1 Insulation shall be CL4FIRE or approved equal fire rated thermal insulation, consisting of a blend of calcium, magnesium and silica with enhanced body solubility characteristics, all totally encapsulated in a reinforced foil wrapper and supplied in roll form. The insulation system shall have the following approvals:
- a. Commercial Kitchen Grease Ductwork Testing Standards:
    - i. Internal - ULC Grease Duct Testing Protocol rated for 0" clearance to combustible materials.
    - ii. External - ISO 6944 Duct A Standard.

- iii. Tested per NFPA-96 to meet all applicable Codes as a gypsum shaft alternative.
    - iv. Warnock Hersey Listed.
  - b. Ventilation Air Ductwork Testing Standards for Emergency Air Supply:
    - i. ISO 6944 Duct A Standard.
    - ii. Warnock Hersey Listed.
- .2 Provide 1.5" (38mm) thickness.
  - a. Provide two layers for kitchen exhaust ductwork to achieve zero clearance in accordance with NFPA-96 and two-hour fire rating.
  - b. Provide fire rated type duct insulation where noted on the drawings on ducts other than kitchen exhaust ducts. Number of layers shall be as required to maintain fire separation of any fire-rated walls that the ducts penetrate.
- .3 Insulation shall be applied directly to the ductwork / piping in strict accordance with the listed system and manufacturers installation instructions.
- .4 All banding and weld-pins shall be installed strictly according to listing requirements.
- .5 Support rods and anchors shall be properly sized and spaced to suit the duct size according to listing requirements.
- .6 All banding, anchors and support rods not matching the system requirements will be removed and replaced.
- .7 The installation shall be reviewed with the manufacturers designated CL4FIRE representative prior to installation and at intervals during the installation. Upon project completion, provide a letter of review and acceptance by the CL4FIRE representative.
- .8 Provide fire stopping at all penetrations of fire rated building construction according to manufacturer's installation requirements.
- .9 Insulation shall run continuously to maintain integrity of the building fire separations
- .10 For kitchen exhaust, insulation shall run continuously from hood in kitchen to top of roof curb to maintain integrity of building fire separations and protect combustibles located within 18" (450mm) of the exhaust duct.

#### 2.5 Acceptable Products List

- .1 Insulation
  - a. Owens-Corning Fiberglas
  - b. Johns Manville
  - c. Manson
  - d. Knauf
  - e. CL4 FIRE
  - f. Firemaster
  - g. Paroc

- h. Armstrong
- i. Imcolock
- j. Rubatex

### **3. ELECTRICAL**

#### **3.1 Electrical Wiring**

- .1 Unless noted otherwise, power wiring for mechanical equipment shall be provided according to the Electrical drawing and specifications. Provide all controls complete with all low voltage wiring (less than 50V) according to Mechanical drawings and specifications.
- .2 Provide starters, overload protection and disconnects for mechanical equipment according to the Wiring for Equipment Schedule on Electrical drawings.
- .3 Line and low voltage electrical work specified in the Mechanical drawings and specifications shall be done in accordance with and to the standards outlined in the electrical specification.
- .4 Control wiring and transformers shall be class 1 or 2 as required by the Ontario Electrical Safety Code (OESC) to suit system operating voltages and currents.
- .5 Control wiring shall be the shielded type and of a type as recommended by the manufacturer. Wiring running concealed shall not run in conduit unless otherwise required by the OESC. Take all necessary precautions to ensure electromagnetic interference from other wiring systems within the building does not affect the operation of the mechanical control systems.
- .6 Where control wiring is installed in return air plenums, use wiring having maximum flame and smoke ratings of 25 and 50 respectively.
- .7 Wiring sizes and transformer capacities shall be suitable to service all control equipment and to accommodate voltage drops in wiring systems.
- .8 Control wiring shall run concealed in all locations (exposed wiring, conduit, wiremold, etc. not permitted). The following instances are exempt from this requirement:
  - a. In the following locations, wiring may run exposed on surface in conduit. Provide conduit where required.
    - i. Wiring running on walls or ceilings in Mechanical / Electrical Rooms.
    - ii. Wiring running on walls or ceilings in rooms with no suspended ceilings. Paint exposed conduit in stage to match architectural finishes.
  - b. Exposed control wiring will not be permitted (run in conduit as described above).
- .9 Additional details regarding the electrical wiring are as follows:
  - a. Control transformers for Building Automation System / motorized dampers shall be supplied and wired by the Mechanical Contractor from power sources provided by the Electrical Contractor where indicated on the drawings. All low voltage wiring to the Building Automation System / motorized dampers shall be by the Mechanical Contractor.

- b. Removal of all power / control wiring greater than 50V for demolished mechanical equipment shall be by the Electrical Contractor. Removal of control wiring less than 50V by the Mechanical Contractor.
- c. For additional wiring requirements for the building automation systems, refer to Division 25.

**END OF SECTION**

## **1. GENERAL**

### 1.1 General Requirements

- .1 Refer to Division 20 – Mechanical.

## **2. FIRE PROTECTION**

### 2.1 General

- .1 This Work consists of the supply and installation of an approved hydraulically designed automatic sprinkler to serve the complete building.
- .2 This Work shall include:
  - a. All design calculations, approved working drawings, installation, flushing and testing, certification and guarantee as generally outlined in these specifications.
  - b. All piping, valves, sprinkler heads, alarm check valve assembly, pumper connection, signs, tamper switches, flow switches, pressure switches, water motor gong, air compressor, spare sprinkler head cabinet (including spare heads and wrenches) etc.
  - c. Include the costs for all permits, approvals, inspections, etc. except that all fees required for the review of the system by the Owner's Underwriter shall be paid by the Owner directly to the Underwriter.
- .3 The working drawings and calculations shall be certified by a certified Professional Engineer licenced to practice in the Province of Ontario and carrying liability insurance. The Contractor shall be responsible for all certification costs.
- .4 Upon completion of the Work, the Professional Engineer retained by the Sprinkler Contractor shall provide a letter indicating the design limitations of the system including height of storage, hazard classification, type of stored products, etc. (as applicable) and certifying that the Work has been installed in conformance with all applicable Codes / Standards and governing authorities. This letter shall be provided in time to allow the issuance of the Building Code Compliance letter by MNE Engineering when directed by the Owner / General Contractor.
- .5 The complete sprinkler system shall be approved by the Owner's Underwriter, the local Fire Department and the local Building Authority. Supply and install in accordance with NFPA 13, NFPA 20, OBC, Provincial Fire Marshall and all applicable Codes / Standards. This Contractor shall investigate and determine all compliance issues prior to submission of tender and carry all cost associated with any and all additional requirements as deemed necessary by the above Standards and/or Authorities.
- .6 The general arrangement of the sprinkler system shall be as follows:
  - a. Unless noted otherwise, provide a wet type sprinkler system to serve areas noted on the drawings.
  - b. Arrange the system so that each floor level is served by at least one water flow alarm assembly.
- .7 Hazard Classification:

- 
- a. The system design shall be based on the "Hazard" classifications to suit NFPA, the Owners Underwriter and all applicable Codes and Standards. For additional details regarding the intended use of the building, refer to the mechanical / architectural drawings.
  - .8 The Sprinkler Contractor shall be responsible for obtaining all necessary information regarding the available water supply to the building prior to submitting the tender price. This shall include all static pressures and flow characteristics. Provide flow measurements where necessary. Adjust the design to suit this data without extra costs. Any utility fees for the flow test shall be included in the tender price.
  - .9 The specification and drawings are intended to be used as a guide only for the complete design and installation of the sprinkler system. All Work shall be complete in all respects whether or not all items are shown on the drawings or described in the specifications.
  - .10 Prior to submitting a tender price, the Sprinkler Contractor shall visit the site to determine the existing conditions and examine all Architectural, Structural, Mechanical and Electrical drawings. The Sprinkler Contractor shall ensure complete familiarity with all drawings and building construction / systems prior to submitting the tender price.
  - .11 Locations of all sprinkler system components, including piping and sprinkler heads, shall be coordinated on site so as not to interfere with the Work of other trades and to be compatible with the mechanical / electrical / structural / architectural layouts shown on the drawings. Design considerations shall include the following:
    - a. All piping shall run as follows:
      - i. At maximum height below the building structure / ductwork (as applicable) and at the approximate level of plumbing systems piping.
      - ii. Unless noted otherwise, all piping shall run concealed within the building construction or within suspended ceilings / bulkheads. For spaces having no suspended ceilings, piping shall run exposed in locations approved by the Consultant.
    - b. All flow switches shall be accessible from floor level without the use of a ladder.
    - c. Some, but not all, obstructions have been indicated on the drawings. Sprinkler protection shall be provided to accommodate all obstructions without extra cost. The full extent of obstructions shall be determined on site prior to submitting the tender price.
  - .12 No material shall be purchased nor shall any work be done until approval on the sprinkler drawings and calculations has been granted by the Consultant, Owner's Underwriter, local Building Authority and the local Fire Department. Any revisions to the working drawings after Owner's Underwriter and local Authorities approval or during construction shall be identified on the drawings and re-submitted for approval and record before proceeding with the Work.
  - .13 Flow / pressure switches, inspector test / drain assemblies and other equipment requiring regular service / access shall be installed in easily accessible locations.
  - .14 The Sprinkler Contractor shall verify prior to submitting shop drawings that the space designated on the drawings for installation of the alarm assemblies complete with associated equipment is adequate and notify the Consultant immediately of any concerns.

- .15 All equipment and controls shall have ULC or CSA approval.

## 2.2 Piping

- .1 All piping, valves, fittings and associated materials and equipment shall be new and furnished and installed in accordance with Owner's Underwriter requirements and all applicable Codes and Standards.
- .2 Sprinkler piping shall be ferrous to NFPA 13 specifications. Plastic piping will not be permitted.
- .3 Fittings and joints for all sprinkler lines shall be screwed, flanged or rolled grooved to NFPA 13 specifications.
- .4 Additional requirements for rolled grooved piping shall be as follows:
- a. The grooved piping shall be installed in accordance with the manufacturer's guidelines and recommendations. All grooved couplings, fittings, valves, and specialities shall be supplied by a single manufacturer. Grooving tools shall be supplied by the same manufacturer as the grooved components. The gasket style and elastomeric material (grade) shall be verified as suitable for the intended service as specified. Gaskets shall be molded and produced by the grooving system manufacturer. Grooved end shall be clean and free from indentations, projections, and roll marks in the area from pipe end to groove for proper gasket sealing.
  - b. Victaulic or approved equal fittings for roll or cut grooved steel piping systems shall be ULC listed and FM approved, ASTM A536 ductile iron, short radius, FireLock fittings or standard ductile iron or steel fittings designed to accept Victaulic couplings.
  - c. Victaulic or approved equal couplings shall consist of two ASTM A536 ductile iron housing, pressure-responsive, synthetic rubber gasket (FlushSeal design required for dry systems) and plated steel bolts and nuts.
    - i. Rigid Type: Housings shall be cast with offsetting, angle-pattern bolt pads to provide system rigidity and support and hanging in accordance with NFPA 13. Victaulic FireLock EZ Style 009 'Installation Ready' stab-on coupling (1 ¼" (32mm) to 4" (100mm) ) and Victaulic FireLock Style 005 standard rigid coupling (5" (125mm) and Larger).
    - ii. Flexible Type: Use in seismic areas where required by NFPA 13. Victaulic Style 75 or 77.
    - iii. Victaulic flange adapters shall be ASTM A536 ductile iron, flat faced, designed for incorporating flanged components with ANSI Class 125 and 150 bolt-hole patterns to a grooved piping system. Victaulic Style 741 or 744.
- .5 Hangers and riser clamps shall be ULC listed for fire protection and installed to NFPA 13 and OBC requirements. Where the building structure does not provide adequate support points, provide supplementary structural steelwork for pipe support.

## 2.3 Valves

- .1 All valves shall be ULC listed for fire protection service and approved by Owner's Underwriter, suitable for minimum working pressures of 175 PSI (1200 Kpa.).

- .2 Provide isolation valves upstream of alarm check valve assemblies, flow switches, where required by Code, where required for proper operation / maintenance of the sprinkler systems and where indicated on the drawings.
- .3 Check valves shall be Victaulic Series 717 or approved equal having a ductile iron body to ASTM A-536, grade 65-45-12, stainless steel spring and shaft, rated to 250 Psig (1725 Kpa). 2.5" (63mm) to 3" (75mm) valves shall have PPS coating, aluminum bronze non-slam tilting disc with Grade 'E' EPDM seal, UL listed. 4" (100mm) to 12" (300mm) valves shall have black enamel painted body with integrally welded on nickel alloy seat, Grade 'E' EPDM encapsulated ductile iron disc, 0.5" (13mm) drains which are upstream and downstream of the disc, UL listed and FM approved. Where required, provide Series 717R valve having drilled, tapped and plugged downstream 2" (50mm) drainage outlet and 0.5" (13mm) pressure taps both upstream and downstream of the disc, UL listed and FM approved.
- .4 Ball valves shall be Victaulic Firelock Series 728 or approved equal, UL listed with flow characteristics exceeding UL Specification 1091 and Factory Mutual Approval Standard 1112. Valves 1" (25mm) to 2" (50mm) shall have bronze body conforming to ASTM 584 Alloy 844, chrome plated brass ball, 316 stainless steel blowout proof stem, TFE seat and grooved or threaded ends to suit piping, rated to 350 Psig (2410 Kpa) working pressure. Provide an approved weatherproof manual actuator suitable for indoor or outdoor use with two pre-wired single pole, double throw supervisory switches monitoring the open position. Where required, provide a 0.25" (6mm) tap on the inlet side.
- .5 Butterfly valves shall be Victaulic Series 705W or approved equal, UL listed for UL Butterfly Specification 1091 and FM Approval Standard 1112. Valves 2.5" (63mm) to 12" (300mm) shall have a ductile iron body conforming to ASTM A-536, grade 65-45-12, coated with a polyphenylene sulfide blend, a disc of ductile iron conforming to ASTM A-536, Grade 65-45-12, with EPDM coating providing bubble tight shut-off, grooved ends, rated to 300 Psig (2065 Kpa) working pressure. Provide an approved weatherproof manual actuator suitable for indoor or outdoor use with two pre-wired single pole, double throw supervisory switches monitoring the open position. Where required, provide Series 705W valve having a 0.25" (6mm) tap on the inlet side.
- .6 Inspectors test connection shall be Victaulic Test Master II Alarm Test Module Style 720 or approved equal having grooved or threaded ends to suit piping, bronze body, dual polycarbonate sight glasses, pressure relief valve, bronze valve bonnet, malleable iron handwheel, rated to 300 Psig (2065 Kpa) working pressure.

#### 2.4 Alarm Check Valve Assembly

- .1 Furnish and install sprinkler alarm check valves as indicated / required, ULC listed for fire service, in accordance with Owner's Underwriter and NFPA 13 requirements, and as follows:
  - a. For wet systems, Victaulic Firelock Series 751 or approved equal spring assisted Alarm Check Valves, UL listed and FM approved, suitable for vertical or horizontal installation, supplied with Grade 'E' EPDM clapper seal, housing cast of ductile iron conforming to ASTM A-536, Grade 65-45-12, serviceable without removal from the line, with grooved or flange by groove ends to suit piping system, rated to 300 Psig (2065 Kpa) working pressure (8"(200mm) rated to 225 Psig (1550 Kpa) working pressure).

- .2 Install complete alarm check valve station, including all valves, flow / trouble pressure switches, valve tamper switches, etc. complete with contacts to suit fire alarm system and in accordance with manufacturers instructions / all authorities having jurisdiction. Provide all necessary drains, alarms, test connections, gauges, isolation valves, bleeder test valve, etc. All drains shall discharge to the exterior of the building.
- .3 The Sprinkler Contractor shall verify prior to submitting shop drawings that the space designated on the drawings for installation of the alarm check valve stations complete with associated equipment is adequate and notify the Consultant immediately of any concerns.
- .4 Where desired by the Contractor, and where approved by all Authorities having jurisdiction, the wet system alarm valve assembly may be substituted with appropriate flow switches complete with upstream isolation valves and downstream inspector test assemblies.

### 2.5 Sprinkler Heads

- .1 Provide spray type fusible sprinkler heads to NFPA 13 requirements, ULC listed for fire service and of types to suit application. Sprinkler heads in all cases to be of the proper degree of fusibility for the locations and hazards involved.
- .2 General use sprinklers shall be Victaulic model V27, V36, V38 or approved equal UL listed, with frame of die cast brass, Teflon encapsulated Belleville spring seal, and frangible glass bulb. The bulbs shall be standard or quick response type with temperature rating to suit application. Provide additional specialty type heads to suit the requirements of this specification.
- .3 Provide standard recessed pendant, concealed, upright and recessed horizontal sidewall sprinkler heads as required and as follows:
  - a. All sprinkler heads installed in drywall ceilings shall be the concealed type.
  - b. All sprinkler heads in T-bar ceilings shall be recessed pendant type.
  - c. Except as otherwise noted, provide upright heads in all areas not having suspended ceilings.
  - d. Sidewall sprinkler heads may be used where desired and where required to suit the application. Heads shall be recessed type except that sprinklers not installed in finished walls may be exposed type.
- .4 Sprinkler head finishes shall be as follows:
  - a. All recessed pendant and recessed sidewall heads shall have a chrome plated or white polyester finish complete with escutcheon plate.
  - b. All upright heads shall be of natural bronze finish except that heads in the Pool Room shall be complete with a black teflon finish.
  - c. Exposed type sidewall heads shall be of natural bronze finish.
- .5 Sprinkler heads shall be centered in T-bar ceiling tiles in the 2'-0" (600mm) dimension and centered or installed at quarter points in the 4'-0" (1200mm) dimension.
- .6 Furnish one approved metal cabinet containing a minimum of two spare sprinkler heads of each type (maximum of 12 spare heads total) and temperature rating and necessary tools for

replacing same. For exact requirements refer of NFPA 13. Locate in the Sprinkler Room adjacent to the incoming water service.

- .7 Provide sprinkler coverage below obstructions according to Code requirements, including ductwork and overhead doors.
- .8 The sprinkler bulb protector must remain in place until the sprinkler is completely installed and before the system is placed in service. Remove bulb protectors carefully by hand after installation. Do not use any tools to remove bulb protectors.

## 2.6 Nameplates

- .1 Supply nameplates as listed below and to the standards specified in Division 20.
- .2 All lamacoid plates shall have red letters on a white background and shall be 2.5" (63mm) high.
- .3 Signs for valves shall be to NFPA 13 requirements and shall be as follows:
  - a. At the Inspector's test connection valve, provide nameplate reading 'SPRINKLER TEST VALVE'.
  - b. Label flow switches as to the building area served.
  - c. Provide all other system identification according to Owner's Underwriter requirements and latest applicable standards and regulations.

## 2.7 Supervisory Switches

- .1 For valves not equipped with integral supervisory capability, provide add-on switches, Potter Electric Signal Co. or approved equal as follows to suit the valve type:
  - a. Model PCVS-2 having the following features:
    - i. UL / CUL Listed, FM Approved and CE Marked.
    - ii. NEMA 4X and 6P rated.
    - iii. Capable of being mounted in any position indoors or out and be complete submerged without allowing water to enter the enclosure.
    - iv. The enclosure shall be held captive by tamper resistant screws.
    - v. Two single pole double throw switches.
    - vi. A removable 0.5" (13mm) NPT nipple and adjustable trip rod.
    - vii. Provide all required mounting hardware.
  - b. Model OSYSU-2 having the following features:
    - i. UL / CUL Listed, FM Approved and CE Marked.
    - ii. NEMA 4X and 6P rated.
    - iii. Capable of being mounted in any position indoors or out and be complete submerged without allowing water to enter the enclosure.
    - iv. The enclosure shall be held captive by tamper resistant screws.
    - v. Two single pole double throw switches.
    - vi. A visual indicator to display the status of the switches.
    - vii. It shall be possible to make fine adjustments to the position of the switch on the valve without loosening the mounting bracket from the valve.
    - viii. An adjustable length trip rod and roller.
    - ix. A removable 0.5" (13mm) NPT nipple and adjustable trip rod.
    - x. Provide all required mounting hardware.

- .2 Provide electrically supervised valves in locations indicated on the drawing and where required. All wiring of switches to fire alarm panel by the Electrical Contractor.

### 2.8 Flow Switches

- .1 For piping 1" (25mm) through 2" (50mm) size, UL / ULC / CSFM Listed vane type waterflow alarm switch with pneumatic retard, Potter Electric Signal Co. model VSR-S or approved equal having the following features:
  - a. Single pole, double throw snap action switches.
  - b. Adjustable, instantly recycling pneumatic retard.
  - c. General purpose, die-cast housing having a cover tamper switch.
  - d. Suitable for mounting in a horizontal or vertical pipe.
  - e. Provide paddle size which is compatible with piping.
- .2 For piping 2" (50mm) and larger, UL / CUL / CSFM Listed, FM Approved, LPCB Approved vane type waterflow alarm switch with pneumatic retard, Potter Electric Signal Co. model VSR or approved equal having the following features:
  - a. Single pole, double throw snap action switches.
  - b. Adjustable, instantly recycling pneumatic retard.
  - c. General purpose, die-cast housing which is held in place with two tamper resistant screws.
  - d. Suitable for mounting in a horizontal or vertical pipe.
  - e. Provide paddle size which is compatible with piping.
- .3 Provide switches in locations indicated on the drawings and where required. All wiring of switches to fire alarm panel according to electrical requirements.
- .4 Provide switches where required by required alarm zoning of building. All wiring of switches to fire alarm panel according to electrical requirements.

### 2.9 Pressure Gauges

- .1 Winters PCT or approved equal complete with 4.5" (113mm) white aluminum dial, acrylic lens, dual scale (imperial and metric – Psi / Kpa), bronze tube, brass socket, type 304 stainless steel case and adjustable pointer. Provide standard range so that operation is at midpoint of scale.
- .2 Each gauge shall be complete with an isolation valve.
- .3 Install at each alarm valve according to Code requirements, pressure gauges to measure water supply pressure and system pressure.
- .4 Provide pressure gauges where indicated on the drawings and where required by Code / governing authorities.

### 2.10 Drains and Test Connections

- .1 Provide at each alarm valve a 2" (50mm) drain connection discharging to the exterior of the building in a location approved by the Consultant / sanitary sewer.

- .2 Provide test assemblies complete with drainage piping for all flow switches and alarm valve assemblies according to Code requirements. Drainage piping shall terminate outside in a location approved by the Consultant or shall discharge to the sanitary drainage system.
- .3 Test valves shall be located not more than 7'-0" ( 2.1m) above floor. Test valves shall be concealed (unless in mechanical or service spaces) and accessible (locate above T-bar ceilings, not drywall ceilings).
- .4 All piping shall be installed so that the complete system can be drained. Drain piping to alarm assemblies where possible. Where not possible, provide auxiliary drains as required (locations of 'drum drips' for dry systems shall be in heated building areas and approved by the Consultant).
- .5 Do not discharge drain piping over exterior poured concrete surfaces (provide hose for directing discharge to approved surfaces where directed).

#### 2.11 Testing

- .1 The Contractor shall furnish all pumps, gauges and other equipment necessary for tests.
- .2 Where directed, all tests shall be made in the presence of the Consultant or authorized inspector.
- .3 Any defects that develop during the tests shall be promptly remedied and the test re-made all to the complete satisfaction of the Inspector.
- .4 All fire protection piping shall be tested to NFPA and Code requirements
- .5 A report of the test and inspection shall be made to the local Authority and a request made for an approval of the entire installation.

#### 2.12 Electrical

- .1 Unless noted otherwise, all electrical equipment specified in this Section shall be supplied and installed by the Sprinkler Contractor complete with wiring in conduit from a power source provided by the Electrical Contractor within 5'-0" (1.5 meters) of the alarm valves.
- .2 The Sprinkler Contractor shall supply and install pressure switches (for automatic operation of the excess pressure pump and flow / trouble indication at the alarm valve assembly), flow switches and valve tamper switches where indicated and as required. The Electrical Contractor shall wire flow / trouble pressure switches, flow switches and valve tamper switches to the Fire Alarm Control Panel. All other wiring shall be by This Section.
- .3 All electrical equipment and devices shall be CSA approved and ULC listed for fire service.

#### **END OF SECTION**

## **1. GENERAL**

### 1.1 General Requirements

- .1 Refer to Division 20 – Mechanical.

## **2. PLUMBING AND DRAINAGE**

### 2.1 Supports

- .1 Provide all of the required pipe hangers and supports.
- .2 Pipe and equipment supports shall be Taylor Walraven or approved equal of spacing and type as recommended by manufacturer, in accordance with Code requirements and in accordance with good commercial standards.
- .3 Provide supports to secure pipes, prevent pipe vibration, maintain required grading, allow for expansion and contraction and produce a neat appearance. Design for strength and rigidity to suit loading and services, prevent undue stress to structural members and with provision for vertical adjustment after piping is erected.
- .4 Anchor / support risers so that weight is not transferred to connected horizontal piping.
- .5 Offset hanger pipe and structural attachments in such a manner that rod is vertical when piping is hot and is subject to tensile loading only.
- .6 Adjust hanger rods to equalize load.
- .7 For all piping systems specified to have insulation with a continuous vapour barrier, oversize pipe hangers and supports to accommodate insulation.
- .8 Provide supplementary structural steelwork where structural bearings do not exist.
- .9 Where supporting from open web steel joists, attach supports to the approval of the structural engineer and comply with the following:
  - a. For all piping, attach supports to the top angle iron section of joists only.
  - b. For piping 3" (75mm) and larger running parallel to joists, provide supplementary steelwork so that piping is supported from a minimum of two joists.
  - c. Support from panel points only.
  - d. Hanger spacing shall not exceed 10'-0" (3.0m).
- .10 Special care shall be taken to ensure all plastic piping is supported according to the recommendations of the pipe manufacturer and as follows:
  - a. Piping shall be supported as close as practical to the change-of-direction fittings to eliminate torsional stress.
  - b. Sharp support or sharp edges shall not be used.
  - c. All valves shall be braced against operating torque.

### 2.2 Domestic Water Piping

- 
- .1 Above Ground (Contractor to choose desired type):
- a. 3" (75mm) and under: type "L" hard copper tubing with sweat wrought copper pressure type solder joint fittings. Alternatively, grooved piping and fittings may be used as specified elsewhere in this specification.
- .2 Connections
- a. Lead-free solder for Type L copper.
- .3 Grooved Piping
- a. For above ground copper domestic water piping 2.5" (63mm) and larger, a grooved mechanical pipe system as manufactured by Victaulic or approved equal may be used as follows:
- i. All grooved components (couplings, fittings, valves, gaskets, bolts and nuts) shall be of one manufacturer and conform to local codes. Grooving tools shall be of the same manufacturer as the grooved components.
- ii. The system shall use mechanical pipe couplings of a bolted type with a center-leg pressure-responsive gasket along with grooved end copper or bronze fittings.
- iii. The system shall be Manufactured to copper tube dimensions. (Flaring of tube or fitting ends to accommodate alternate sized couplings is not permitted.) Basis of Design: Victaulic Copper Connection.
- iv. Copper tube shall comply with ASTM B-88 type L, roll grooved only in accordance with Victaulic current listed standards.
- v. Couplings shall be either of the following:
- 1) Couplings shall be Victaulic Style 607 QuickVic Installation Ready stab-on coupling designed for direct stab installation onto roll grooved copper tube without prior field disassembly and no loose parts. Gasket shall be center-leg, with pipe stop to ensure proper groove engagement, alignment, and pipe insertion depth.
- I Grade 'P' Fluoroelastomer, UL classified in accordance with NSF-61 for potable water service.
- II Grade EHP EPDM suitable for water temperatures up to 250 deg F (121 deg C) and oil-free compressed air systems with plated steel bolts and nuts.
- 2) Coupling housings shall be cast of ductile iron conforming to ASTM A-536, Grade 65-45-12, with offsetting angle-pattern bolt pads and a copper color alkyd enamel paint coating, as manufactured by Victaulic.
- vi. Gaskets:
- 1) Gaskets shall be molded of synthetic rubber in a Center-leg configuration conforming to the copper tube size outside diameter and coupling housing of elastomers having properties as designated in ASTM D-2000.
- 2) Gaskets used for potable water shall be Grade "P" Fluoroelastomer compound with red and blue color code designed for operating temperatures from 0 deg F to +180 deg F.
- 3) Gaskets used for water from -30 to +250 deg F (-34 to +121 deg C) shall be Grade EHP EPDM compound and gaskets used for water

- from -30 to +230 deg. F (-34 to +110 deg. C) shall be Grade E EPDM compound, molded of materials conforming to ASTM D-2000, designation 2CA615A25B24F17Z.
- vii. Flange adapters:
    - 1) Flange adapters 2" (50mm) to 6" (150mm) shall be Victaulic style 641, ductile iron ASTM A-536, Grade 65-45-12, engaging directly into roll grooved copper tube and fittings and bolting directly to ANSI Class 125 cast iron and Class 150 steel flanged components. Flange casting shall be as specified above for coupling housings.
  - viii. Fittings and coatings:
    - 1) Fittings shall be Victaulic full flow, standard radius copper fittings with grooves designed to accept Victaulic grooved end couplings. Standard fittings shall be copper per ANSI B16.22 or ASTM B-75 alloy C12200; bronze sand castings per ASTM B-584 copper alloy CDA 844 (81-3-7-9) per ANSI B16.18.
    - 2) Use Victaulic style 647 dielectric waterway when connecting dissimilar metals in liquid systems. Copper-silicon casting conforming to UNS C87850, and UL classified in accordance with ANSI / NSF-61 for potable water service.
  - ix. Mechanical-T:
    - 1) Mechanical-T bolted branch outlet shall be Victaulic Style 622 consisting of a cast bronze upper housing with holefinder locating collar and female threaded NPT outlet. Ductile iron lower housing with copper-colored enamel coating, pressure-responsive, synthetic rubber gasket and plated steel bolts and nuts.
  - x. Valves:
    - 1) Victaulic series 608N butterfly valve, 2.5" (63mm) through 6" (150mm) rated at 300 Psig (2065 Kpa) and complete with grooved ends and cast brass body to CDA-836 (85-5-5-5). The disc shall be aluminum-bronze Fluoroelastomer pressure responsive seat and stainless steel stem. (Stem shall be offset from the disc centerline to provide complete 360-degree circumferential seating.) Seat test to MSS-SP-67. Bubble tight, dead-end or bi-directional service. Provide memory stop for throttling, metering or balancing service. UL classified in accordance with NSF-61 for potable water service, and meets the lead content requirements of NSF-372.
- b. The complete pipe system, including supports, shall be to manufacturers' recommendations. A grooved piping system representative shall provide on-site training to the Contractors field personnel in the proper use of grooving tools and installation of grooved piping products. The factory trained representative shall periodically review the product installation. The Contractor shall remove and replace any improperly installed products.

### 2.3 Sanitary Drain and Vent Piping

- .1 Above Ground (Contractor to choose desired type):
  - a. 2" and under: type DWV hard drawn copper tube with cast brass alloy drainage fittings.
  - b. Over 2": Cast iron pipe with "MJ" fittings or DWV copper tubing with cast alloy drainage fittings.

- c. All sizes: PVC DWV pipe with injection-molded socket fittings. Pipe shall be suitable for use in non-combustible building construction (IPEX System 15 or approved equal). For piping running through return air ceiling plenums, piping shall have a maximum smoke developed rating of 50 (IPEX System XFR 15-50 or approved equal).
- .2 Connections:
  - a. 50-50 lead-tin solder for DWV copper.
  - b. Stainless steel screw clamps and elastomer sleeve for mechanical joint cast iron soil pipe, Bibby-Ste-Croix series 2000 or approved equal.
  - c. Solvent weld all socket fittings according to manufacturer's recommendations.
  - d. For PVC pipe using gasketed connections, use manufacturer approved PVC pipe lubricant.
- .3 All piping shall conform to or be certified by the appropriate CSA standard according to OBC requirements.
- .4 Exposed piping will not be permitted at fixture connections (piping within cabinet spaces is not considered exposed). Use only fixture trim components as specified in the Equipment Schedule or, if not specified, copper piping.
- .5 Un-insulated plastic piping will not be permitted to run exposed in any location. Use only copper or cast iron piping in these locations.
- .6 Plastic piping will not be permitted for individual piping branches to floor drains which could receive discharge from hot water relief valves, commercial dishwasher outlets, etc. (to prevent pipe damage from extreme temperatures of waste discharge). Use only copper or cast iron piping for these applications for a minimum distance of 15'-0" (4.5m) from the floor drain outlet.

#### 2.4 Condensate Drain Piping

- .1 Condensate drain shall be type M copper, hard drawn with sweat wrought copper pressure type solder joint fittings. Connections shall be made using lead-free solder. Pipe to discharge to floor drain / floor level as noted on the drawings.

#### 2.5 Natural Gas Piping

- .1 Piping shall be black steel schedule 40 to ASTM A53 or A106 with screwed malleable iron or steel fittings up to 2" (50mm) and welded fittings over 2" (50mm). All piping and fittings (including pipe thread tape) shall comply with the requirements of the latest issue of CSA B149.1.
- .2 De-energize and re-energize all affected natural gas systems to permit the revisions indicated on the drawings. Re-light all existing natural gas equipment affected by the new Work.
- .3 The gas distribution system shall be supplied, installed, tested and identified according to CSA International B149.1-20 Natural Gas And Propane Installation Code and local authority requirements. All outside piping shall be painted (identification banding not acceptable).
- .4 Mount and fasten all gas piping running on roof on one of the following:

- a. Roof Top Blox or approved equal model RTB-01 having the following features / accessories:
  - i. Black UV stabilized high density polyethylene, 0.1" (2.5mm) to 0.135" (3.4mm) wall thickness.
  - ii. Base material shall be 1" (25mm) thick by 25 lb. density Type 3 closed cell extruded polystyrene foam.
  - iii. Supports shall have end-to-end interlocking capability.
  - iv. Load bearing capability up to 450 lbs. (205 Kg.). For loads over 250 lbs. (115 Kg.), provide model STR-04 galvanized slotted steel strut channel.
  - v. Screw indents to guide fastening screws into internal engineered thread gripping feature.
  - vi. Top surface easily adapts to all types of piping clamps, clips, slotted strut and 0.375" (9.4mm) or 0.5" (13mm) treaded rod.
  - vii. All pipe fastening and height adjustments shall be done from the top side only.
  - viii. Provide all accessories required for mounting of piping, including (where applicable) model XTB-02 height extension, model ROD-03 zinc plated extension rods, model STR-04 galvanized slotted steel strut channel, etc
  - ix. All supports shall have the capability to fasten pipe clamps.
  - x. Provide galvanized pipe clamps / fasteners at all supports for pipe attachment. Clamps shall be one size larger than the pipe.
  - xi. Refer also the detail on the drawings.
- b. Mifab CXP / C series (as applicable) or approved equal block supports manufactured completely of UV resistant 100% recycled rubber. Provide CE extension series where required by elevation of piping.
  - i. All supports shall have the capability to fasten pipe clamps.
  - ii. Provide galvanized pipe clamps / fasteners at all supports for pipe attachment. Clamps shall be one size larger than the pipe.
- c. Refer also the detail on the drawings.

## 2.6 Plastic Piping

- .1 Prior to installation of any plastic piping:
  - a. Obtain ULC approved installation instructions from the firestop manufacturer for all firestops throughout the complete project. Where ULC approved products cannot be obtained to suit all pipe configurations and building constructions, use copper or cast iron piping only.
  - b. Verify that the proposed types and locations of plastic piping are acceptable to the local authority and modify work as required without extra cost.
- .2 Do not store plastic piping in direct sunlight.

## 2.7 Sanitary Cleanouts

- .1 Zurn or approved equal of the following types (Contractor to choose applicable type):
  - a. At the base of each vertical stack and rainwater leader, provide Z-1445 with dura coated cast iron body and gas and watertight ABS tapered thread plug.

- b. In terrazzo or quarry tile floor areas, provide ZN-1602-Z complete with dura coated cast iron body, neoprene body sleeve, polished nickel bronze adjustable head and round recessed top.
  - c. In ceramic tile and vinyl floor areas, provide ZN-1602 complete with dura coated cast iron body, neoprene body sleeve, polished nickel bronze adjustable head and round top.
  - d. In unfinished floor areas, provide ZXN-1612 with dura coated cast iron body, neoprene body sleeve, polished nickel bronze adjustable head and heavy duty scoriated top. For floor cleanouts in the Warehouse, provide ZN-1400-HD, adjustable floor cleanout with dura coated cast iron body, neoprene body sleeve, polished nickel bronze adjustable head and heavy duty cast iron scoriated top.
  - e. In piping systems not terminating through building finishes, provide compatible cleanout fittings as manufactured by the pipe manufacturer. Access doors shall be provided as specified elsewhere in the specification.
- .2 Cleanouts have been indicated where desired in specific locations. In all other locations, provide cleanouts according to Ontario Building Code requirements and/or where directed by the local authority. Cleanouts shall be installed tight to walls where indicated on the drawings.
- .3 Install floor cleanouts where shown on the drawings and where required with top edge flush or maximum 0.125" (3.1mm) below finished floor elevation.

## 2.8 Floor Drains

- .1 Zurn or approved equal of the following types (Contractor to choose applicable type):
- a. In vinyl tiled and ceramic floor areas, provide ZN-211-B5-P complete with dura coated cast iron body, bottom outlet, adjustable 5" (125mm) diameter polished nickel bronze round strainer and trap primer connection.
  - b. In unfinished concrete floor areas, provide ZX-211-A5-P complete with dura coated cast iron body, bottom outlet, adjustable with 5" (127mm) diameter 0.5" (13mm) thick cast iron heavy duty round strainer and trap primer connection.
  - c. In quarry tile or terrazzo floor areas, provide ZXN-211-H-P complete with dura coated cast iron body, bottom outlet, adjustable 6" x 6" (150mm x 150mm) square heavy duty nickel bronze strainer and trap primer connection.
- .2 Install floor drains where shown on the drawings with top edge flush or maximum 0.125" (3.1mm) below finished floor elevation. Co-ordinate the exact location of all floor drains on site and adjust to suit the floor slopes as directed by the General Contractor.

## 2.9 Valves

- .1 General
- a. All valves shall have a pressure rating suitable for the system operating pressure. All valves shall meet MSS-SP-25, the manufactures name and pressure ratings are clearly marked on the body of the valve. Valves to meet current MSS specifications.
  - b. Similar valves shall be of the same manufacturer.
  - c. All valves supplied for this project shall have a current and valid Canadian Registration Number for the Province of Ontario with TSSA. Suppliers shall provide a copy of the Statutory Declaration for valves, stamped, signed and dated by TSSA as

- 
- validation of the CRN registration. This shall be provided along with the shop drawing submittal package.
- d. Provide stem extensions / extended necks as required to suit insulation thickness.
  - e. All domestic water valves shall be lead-free compliant containing less than 0.25% lead by weight copper alloy bodies. Valves to be certified to NSF 372: Use only original manufactured valves meeting ANSI, ASTM, ASME and applicable MSS standards.
  - f. Provide lead free paste when soldering lead free valves.
- .2 Fixtures:
- a. Each fixture supply shall have a shut-off valve. Exposed valves and piping to be chrome plated.
- .3 Isolation Valves (Domestic Hot and Cold Water):
- a. Sizes 0.5" (13mm) to 2" (50mm): 1034 kPa (150 psig) / 600 W.O.G., Brass Body to ASTM C49300 (Lead Free Brass), Full Port, PTFE Seats, Double "O" Ring, Stainless Steel Ball, Blowout Proof Stem, Lever Handle.
    - i. Threaded valves: Kitz 858 or approved equal.
    - ii. Soldered valves: Kitz 859 or approved equal.
  - b. Sizes 2.5" (63mm) to 10" (250mm): American Valve #4000 or approved equal. Cast Iron ASTM A126 Class B Body, Epoxy Coated to NSF 61/NSF 372. Teflon Fused Ball, RPTFE Seats, Seals and Packing, Tapped & plugged boss for venting or draining downstream side. Full Port up to 6", Locking Lever Operated, and Gear Operated.
  - c. Sizes 2.5" (63mm) and larger: Butterfly valve, 1380 KPA / 200WOG Rating. Butterfly valves shall be lugged type, Epoxy Coated Ductile iron body, with 2" extended neck to allow for insulation, stainless steel disc, PTFE (with EPDM backing) bonded seat, stainless steel stem with top and bottom bushings of dissimilar material. Valve shall have bubble tight shut-off to 200PSI when downstream flange is removed (Full dead-end service). Valves 150MM (6") and smaller shall have locking lever operator, valves 200MM (8") and larger shall have locking Manual Gear operator.
    - i. MAS L-D-4-S-PE-LH (Lever) or approved equal.
    - ii. MAS L-D-4-S-PE-G (Gear) or approved equal.
- .4 Isolation Valves (Natural Gas):
- a. Sizes 0.25" (6mm) to 2" (50mm): MAS B3, Kitz 58, Toyo 5044A. 150PSIG/ 600WOG Rating, Brass body, Full port, TFE seats, Double O-Ring Design, or Teflon packing, Chrome plated solid Bronze ball, 3.16 Rating, CGA/CSA Approved, and Lever Handle.
  - b. Sizes 2.5" (63mm) and larger: Kitz 150 SCTDZM-N. Class 150 Flanged, Carbon Steel A216WCB Body, S.S. Ball & Stem, PTFE packing, Co-Polymer Hypatite seats, Locking Lever or Gear.
  - b. All exterior valves not located on the roof shall be complete with removable handles.
  - c. All valves shall be manufactured in accordance with International Fuel Gas Code, CGA 3.16, UL, CGA-B 149.M91 as revised.
- .5 Drain Valves:
- a. 860 kPa (125 psig) / 200 W.O.G. bronze body to ASTM C89530 (Lead Free Bronze), Screwed Cap C49300 (Lead Free Brass), Integral Seat, Bronze or PTFE Disk.

- i. Threaded valves: Kitz 868C or approved equal.
- ii. Soldered valves: Kitz 869C or approved equal.
- b. Where required by the local authority, provide tamper proof vacuum breaker.

#### 2.10 Shock Absorbers

- .1 Shock absorbers shall be located and sized in accordance with Plumbing and Drainage Institute standard no. WH201-PD-1. Absorbers shall be Zurn Wilkins or approved equal, 1250XL series.

#### 2.11 Trap Seal Primers

- .1 Traps and trap seal primers shall be provided for all floor drains / standing wastes according to OBC requirements (traps and primers not shown on drawings).
- .2 Trap seal primer valves and distribution units shall be Precision Plumbing Products Inc. or approved equal. Provide model P-2 primer valve for one or two drains, Model P-1 primer valve for one to four drains. Primer valves to be installed with Precision Plumbing Products model DU-4 or DU-U distribution units or suitable fabricated header.
- .3 Where desired by the Contractor, where directed by the local authority or where required to maintain a proper trap seal:
  - a. Provide Precision Plumbing Products Inc. model MPB-500-115V or approved equal electronic primer designed to serve one to four drains. The primer shall be 120-1-60 and shall be complete with model DU distribution unit, cabinet enclosure, circuit breaker, test switch, UL listed timer solenoid valve and plug-in power cord. The electrical assembly shall be listed to UL #73.
  - b. Provide Precision Plumbing Products Inc. series PTS or approved equal electronic primer designed to serve from 4 to 30 drains. The primer shall be 120-1-60 (hard wired) and shall be complete with atmospheric vacuum breaker, pre-set 24 hour clock, manual over-ride switch / test button, solenoid valve, 0.75" (19mm) FNPT connection calibrated manifold for equal water distribution and 0.5" (13mm) outlet compression fittings.
- .4 Install units according to manufacturer's recommendations and as follows:
  - a. On an active domestic cold water main (1.5" (38mm) or smaller) where pressure fluctuations will ensure proper operation of the primer. The branch piping running to the primer shall connect to the top of the cold water main only (to prevent debris from entering the primer).
  - b. With a minimum elevation above the floor drain as directed by the manufacturer.
  - c. With an isolation valve immediately upstream of each primer.
  - d. For electric priming systems, all wiring from the 120V power sources shall be by This Contractor. 120V power sources shall be provided by the Electrical Contractor where indicated on the HVAC drawings. These have been designated for use with the automatic temperature control / building automation systems but may also be used as a power source for trap seal primer valves.
  - e. Headers (where used): provide 0.5" (13mm) header piping and 0.5" (13mm) branch piping from header to each floor drain. Arrangement piping for equal water flowrates to all drains.

- f. Electric primer panels shall be located to the approval of the Consultant.

## 2.12 Piping Installation Requirements

- .1 Piping shall be installed according to good commercial standards and approximately as follows:
  - a. All piping running vertically shall run concealed in wall construction / furred enclosures unless noted otherwise on the drawings.
  - b. Use compression joints, unions, flanged or grooved joints in sufficient quantities to facilitate removal of equipment, fixtures, etc. without removal of long lengths of pipe.
  - c. Install eccentric reducers in horizontal piping to permit drainage and eliminate air pockets.
  - d. Where pipe sizes differ from connection sizes of equipment, install reducing fittings close to equipment. Reducing bushings are not permitted.
  - e. All valves and other pipe accessories shall match the associated pipe size unless noted otherwise.
  - f. Cut ends of pipes square, ream, clean scale and dirt and assemble without binding.
  - g. Install copper tubing so that it is not in contact with dissimilar metal and will not be kinked or collapsed.
  - h. Plug or cap pipe and fittings to keep out debris during construction.
  - i. All piping shall be laid straight and in true alignment to the slopes of the pipe, as indicated on the drawings and / or as directed.
  - j. Install piping free from strains and with proper allowance and off-sets for thermal expansion and contraction, with anchors placed as shown or required.
- .2 Piping shall be graded as follows:
  - a. Water Piping: Minimum 1/20" per foot (0.43mm/100mm) length. Insure all piping can be drained and provide drain valves at all low points.
  - b. Sanitary Drains: Minimum slopes as required by Code or as otherwise noted on the drawings.
  - c. Condensate Drains / Relief Piping: Minimum 2%.
- .3 Keep all sanitary and water piping clear of outside walls and combustion air openings unless otherwise noted on the drawings / unless otherwise required by site conditions / unless otherwise approved by the Consultant. It is the responsibility of this Contractor to ensure that water lines in outside walls are installed on warm side of building insulation and adequately covered with insulation. It is the responsibility of this Contractor to ensure that plumbing piping is installed so that freezing conditions within the pipe do not occur.
- .4 All drainage piping exposed in accessible pipe chases, utility and similar rooms shall be cast iron or copper only.
- .5 Install plastic piping in accordance with manufacturers product data, including product technical bulletins, installation instructions and product carton instructions for installation.

## 2.13 Plumbing Fixtures

- .1 Plumbing fixtures complete with trim shall be of the manufacturer's listed in the Schedule on the drawings or approved equal. Colour of fixtures (except stainless steel fixtures) shall be white.
- .2 Connect plumbing fixtures and equipment to the water supplies, wastes, traps and vents in accordance with the Ontario Building Code. Traps and vents are not shown on the drawings. All fixtures shall be served from wall unless noted otherwise on the drawings.
- .3 Set fixtures level, square and centered with relation to floors, walls, and partitions, a standard height from floor to rim unless otherwise shown on drawings and / or directed by the Consultant. All fixtures designated for handicap use shall be mounted at the required height (refer to Architectural drawings for additional information regarding required mounting heights)
- .4 Attach plumbing fixtures in an approved manner complete with all required flanges, gaskets, bolts, nuts, etc. Seal around all fixtures.
- .5 Branch piping to individual plumbing fixtures shall be sized as shown in the Plumbing Branch Piping Schedule on the drawings.
- .6 Approximate mounting heights of fixtures, as measured from finished floor/grade level shall be as follows unless noted otherwise on the drawings:
  - a. Countertop sink: Countertop level.
  - b. Wall-hung lavatory: 31" (775 mm) to overflow rim.
  - c. Wall-hung barrier-free lavatory: 34" (865 mm) to overflow rim.
  - d. Water closet: 15" (375 mm).
  - e. Barrier-free water closet: 17" (430 mm) to 19" (485 mm) to top of seat.
  - f. Mop sink faucet: 36" (900 mm).
  - g. Emergency eye wash / shower: As per ANSI/ISEA Z358.1 standard.

#### 2.14 Draining Water Systems

- .1 Drain and refill as applicable all existing water systems as required to permit revisions as indicated on the drawings.

#### 2.15 Testing and Inspection

- .1 Test drainage, vent and domestic water piping to Plumbing Code requirements. Test natural gas piping systems to Gas Code requirements. Repair all leaks to the inspection authority and / or the Consultant's approval.
- .2 All leaks shall be repaired by remaking the joint. After piping systems have been tested and repaired, repeat tests.
- .3 All equipment / devices which may be damaged by test pressures shall be isolated during testing procedures.
- .4 Test and sample for lead for drinking water fixtures affected by the Work. Samples shall be laboratory tested and results reported in accordance with O. Reg. 243/07.

---

2.16 Cleaning and Flushing

- .1 Flush and clean all new and existing affected piping in the following sequence:
  - a. Flush with potable water for a minimum time period of 30 minutes. During flushing and cleaning maintain all isolating valves in the open position. Remove faucet strainers during flushing and replace once flushing is complete.
  - b. Disinfect all new piping for three hours using a 200 ppm chlorine solution.
  - c. After disinfection, flush all new and affected existing piping with potable water for a minimum time period of 30 minutes.
  - d. Perform a water quality / bacteria analysis prepared by an independent lab to verify that the domestic water system downstream of each Tenant water meter is clean and suitable for consumption. Take each sample at the most downstream end of each piping system.
- .2 All cleaning and flushing of the domestic water site service piping shall be by the Site Service Contractor.
- .3 During flushing and cleaning maintain all isolating and control valves in the open position.

2.17 Approved Products List

- .1 Plumbing Fixtures
  - a. American Standard
  - b. Kohler
  - c. Mansfield
- .2 Mop Sinks
  - a. Fiat  
Stern Williams
  - b. Zurn
  - c. Mustee
- .3 Plumbing Trim
  - a. Delta Commercial
  - b. Moen Commercial
  - c. Sloan
  - d. Chicago
- .4 Stainless Steel Sinks
  - a. Franke
  - b. Novanni
  - c. Elkay
  - d. Architectural Metal Industries
- .5 Electronic Flush Valves

- a. Delta Commercial
  - b. Sloan
  - c. Toto
- .6 Water Closet Seats
- a. Centoco
  - b. Moldex
  - c. Olsonite
  - d. Beneke
  - e. Bemis
- .7 Eye Wash Stations
- a. Haws
  - b. Guardian
  - c. Bradley
- .8 Domestic Water Mixing Valves
- a. Bradley
  - b. Symmons
  - c. Rada
  - d. Leonard
- .9 Pipe Hangers
- a. Taylor Walraven
  - b. Crane
  - c. Unistrut
  - d. Myatt
- .10 Valves and Strainers
- a. Kitz
  - b. Crane
  - c. Watts
  - d. Toyo
  - e. M.A. Stewart
  - f. Apollo
  - g. Mueller
  - h. Victaulic
- .11 Plumbing Specialties
- a. Zurn
  - b. Ancon
  - c. Mifab
  - d. Jay R. Smith
  - e. Precision Plumbing Products

.12 Roof Gas Pipe Supports

- a. Mifab
- b. Pipe Ease
- c. Nelson / Olsen
- d. Erico

**END OF SECTION**

## **1. GENERAL**

### 1.1 General Requirements

- .1 Refer to Division 20 – Mechanical.

## **2. HYDRONIC SYSTEMS**

### 2.1 Supports

- .1 Provide all required pipe hangers and supports.
- .2 Pipe and equipment supports shall be Taylor Walraven or approved equal of spacing and type as recommended by manufacturer, in accordance with Code requirements and in accordance with good commercial standards.
- .3 Provide supports to secure pipes, prevent pipe vibration, maintain required grading, allow for expansion and contraction and produce a neat appearance. Design for strength and rigidity to suit loading and services, prevent undue stress to structural members and with provision for vertical adjustment after piping is erected.
- .4 Offset hanger pipe and structural attachments in such a manner that rod is vertical when piping is hot and is subject to tensile loading only.
- .5 Adjust hanger rods to equalize load.
- .6 Provide supplementary structural steelwork where structural bearings do not exist.
- .7 Where supporting from open web steel joists, attach supports to the approval of the structural engineer and comply with the following:
  - a. For all piping, attach supports to the top angle iron section of joists only.
  - b. For piping 3" (75mm) and larger running parallel to joists, provide supplementary steelwork so that piping is supported from a minimum of two joists.
  - c. Support from panel points only.
  - d. Hanger spacing shall not exceed 10'-0" (3.0m).

### 2.2 Hydronic Piping

- .1 Above Ground Metal Piping (Contractor to choose desired type):
  - a. Piping to NPS 12" (300mm) shall be ERW or seamless schedule 40, Grade B black steel complying with ASTM A53 / A53M.
  - b. Piping to NPS 3" (75mm) may be type L hard copper complying with ASTM B88.
  - c. Fittings shall be to the following as applicable:
    - i. Malleable iron screwed fittings, Class 150 to ASME B16.3.
    - ii. Malleable iron unions, Class 150 to ASME B16.3.
    - iii. Sweat wrought copper or cast brass soldered fittings for Type 'L' copper piping.
    - iv. All fittings shall be long radius type.
  - d. Connections shall be to the following as applicable:

- i. Piping NPS 2" (50mm) and under: screwed or soldered.
  - 1) For screwed piping connections, use teflon tape (pipe thread taper to ASME B2.1).
  - 2) Where copper piping is used joints shall be 95-5 hard solder.

## 2.3 Valves

### .1 General

- a. All valves shall have a pressure rating suitable for the system operating pressure.
- b. Similar valves shall be of the same manufacturer.
- c. All valves supplied for this project shall have a current and valid Canadian Registration Number for the Province of Ontario with TSSA. Suppliers shall provide a copy of the Statutory Declaration for valves, stamped, signed and dated by TSSA as validation of the CRN registration. This shall be provided along with the shop drawing submittal package.
- d. Provide stem extensions / extended necks as required to suit insulation thickness.
- e. Use only commercial grade valves meeting ANSI, ASTM, ASME and applicable MSS standards. Specification MSS-SP-80, MSS-SP-110, MSS-SP-70, 85, 71, MSS-SP-72, MSS-SP-67, API 602, API 598, API 609, API 600.

### .2 All valves shall be to the following or approved equal:

- a. Up to and including NPS 2" (50 mm), bronze valves as follows:
  - i. Isolation:
    - 1) Ball valve complete with 2 piece forged brass body, stainless steel trim, blowout proof stem, PTFE seats, maintenance free double o-ring stem seals and full port design. Valves shall be pressure rated to 150 WSP / 600 WOG and conform to MSS-SP 110 and certified to CSA.
      - I Threaded valves: Kitz 68AMLL or approved equal.
      - II Soldered valves: Kitz 869AMLL or approved equal.
- b. Circuit Balancing Valves: Victaulic / IMI TA Hydronics valves for precise flow measurement, balancing, and positive shut-off. Each valve to be variable orifice, wye pattern, globe style with self-sealing EPDM measurement points, EPDM seat, and digital handles with locking hidden tamper-proof setting. Valves shall be selected based on flow requirement. Suitable for operating temperatures to 248°F (120°C).
  - i. ½" through 2": 400 psi, non-ferrous Ametal® DZR brass copper alloy body, EPDM O-ring seals. 4-turn digital readout handwheel for balancing, hidden memory feature with locking tamper-proof setting. Brass shall be ISO 6509 compliant. Victaulic / IMI TA Series 786H/787H/78KH. Install Victaulic Koil-Kits including Series 78Y strainer/ball valve/drain (or Series 78T ball valve/drain where strainer not required), with Series 78U union port fitting and coil hoses to complete terminal hookup.
  - ii. Valves shall be installed as follows:
    - 1) With flow in the direction fo the arrow on the valve body.
    - 2) At least five pipe diameters downstream from any fitting.
    - 3) At least 10 pipe diameters downstream from any pump.
    - 4) Two pipe diameters upstream of any fitting.

- 5) With easy and unobstructed access to the valve handwheel and metering ports.
- 6) To prevent sediment build-up in the metering ports.
- c. Drain valves:
  - i. Two piece forged brass body, chrome plated ball, blowout proof stem, PTFE seats / seals, PP or brass cap and chain, full port design. Valves shall be pressure rated to 150 WSP / 600 WOG.
    - 1) Threaded / hose valves: Kitz 68C or approved equal.
    - 2) Threaded / hose valves: Toyo 5046A
    - 3) Soldered / hose valves: Kitz 69C or approved equal.
  - ii. Provide tamper proof vacuum breaker.

#### 2.4 Air Vents

- .1 Automatic air vents shall be Taco model 400 Hy-Vent or approved equal. Install air vents and collecting chambers at high points of heating system, where indicated on the drawings and in all locations where air can be trapped including unit heaters and heating coils. Provide stop cock to facilitate removal of vent without draining the heating system.
- .2 Convector, cabinet heaters and other heating units fed from supply and return mains or branches that are located below radiation units shall be vented with a manual air vent. Manual vents shall be Taco model 417 or approved equal.

#### 2.5 Piping Installation Requirements

- .1 Piping shall be installed according to good commercial standards and approximately as follows:
  - a. All piping running vertically shall run concealed in wall construction / furred enclosures unless noted otherwise on the drawings. Under no condition is any piping to be installed in concealed spaces in outside walls.
  - b. Use unions in sufficient quantities to facilitate removal of equipment without removal of long lengths of pipe.
  - c. Install eccentric reducers in horizontal piping to permit drainage and eliminate air pockets.
  - d. Where pipe sizes differ from connection sizes of equipment, install reducing fittings close to equipment. Reducing bushings are not permitted.
  - e. All valves and other pipe accessories shall match the associated pipe size unless noted otherwise.
  - f. Cut ends of pipes square, ream, clean scale / dirt and assemble without binding.
  - g. Install copper tubing so that it is not in contact with dissimilar metal and will not be kinked or collapsed.
  - h. Plug or cap pipe and fittings to keep out debris during construction.
  - i. All piping shall be laid straight and in true alignment to the slopes of the pipe, as indicated on the drawings and / or as directed.
  - j. Install piping free from strains and with proper allowance and off-sets for thermal expansion and contraction, with anchors placed as shown or required.
  - k. Slope piping up in direction of flow at a minimum rate of 1/20" per foot (0.43mm/100mm) length and provide drain at low points. The entire hot water heating system shall be capable of being drained.

- l. Take heating branches off piping mains at 45 degrees looking up when feeding above and 45 degrees looking down when feeding below.
- m. Provide piping connections to mechanical equipment with valves and unions located so that removal of equipment is possible without disconnecting more than a minimum amount of pipework, shutting down other pieces of equipment or draining the entire system.
- n. Install a minimum of 14" (350mm) straight run piping between pipe elbows, valves, pumps or other fittings unless noted otherwise on the drawings.
- o. Provide clearance for maintenance of equipment, valves and strainers.

#### 2.6 Draining and Refilling the Hot Water Heating System

- .1 This Contractor shall be responsible for draining and refilling the heating system to permit revisions as noted on the drawings.
- .2 All new and affected existing piping system (mains and branch piping) shall be flushed and cleaned as follows, in the specified order:
  - a. Flush using raw water to ensure removal of heavy debris and excessive oil or dirt.
  - b. During flushing, maintain all isolating and control valves in the open position.
  - c. Do not flush piping through equipment which could be damaged by pipe debris (coils, boilers, radiant heaters, etc.). Provide necessary bypass piping.
  - d. All strainers shall then be cleaned.
  - e. Clean with Quatic Chemicals Series 6002 neutral pH cleaner or approved equal. The cleaner shall be introduced into system at a dosage of 2 gallons per 100 gallons (9.0 litres per 455 litres) of water in the system and circulated for 24 hours at ambient temperature.
  - f. The complete system shall then be drained as quickly as possible using all available drain valves.
  - g. Immediately refilled with fresh water and circulate for a minimum of 60 minutes.
  - h. The complete system shall then be drained and refilled. If any foaminess or discoloration is still present, the system will require repeated draining and refilling. Ensure that all residual cleaner has been removed to the approval of the chemical treatment manufacturer.
  - i. Following cleaning / flushing procedures, clean strainers and immediately fill system.
  - j. Make all necessary provisions in the piping system for the introduction of the cleaning chemicals.
- .3 Chemically treat the heating water according to the existing chemical treatment manufacturer's recommendations. All chemicals shall be supplied by Owner and installed by This Contractor.
- .4 Adjust PH levels according to water treatment supplier recommendations so that damage does not occur to the aluminium boilers.

#### 2.7 Hydronic Heating Equipment

- .1 General:
  - a. All heating units shall be Sigma or approved equal of the types listed in the Schedules on the drawings.

- 
- b. Provide for noiseless expansion of all components.
  - c. Radiation output and air / water operating temperatures shall be as indicated on the drawings.
  - d. Installation shall be in strict accordance with the manufacturer's recommendations.
  - e. All cabinets / enclosures shall be complete with primer finish suitable for field painting.
- .2 Wallfin (enclosure only):
- a. Enclosure:
    - i. The enclosure shall be of a type indicated on the drawings.
    - ii. Enclosures shall be manufactured from 16 gauge steel and finished with a primer finish suitable for field painting.
    - iii. The enclosure shall be suitable reinforced to withstand a loading of 150 pounds per linear foot (223 kg. / meter).
    - iv. The enclosure shall be continuous wall to wall or as shown on the drawings.
    - v. Panels shall have a 0.75" (19mm) return edge around the perimeter to provide rigidity.
    - vi. Covers shall be removable by hand without any tools.
    - vii. The top outlet of the enclosures shall have stamped louver grilles that extend the entire length of the panels.
    - viii. The inlet of the enclosure shall be open.
    - ix. Manufacturer shall provide all accessories (endcaps, trim pieces, corners, hanger strips, brackets, joiner pieces, etc.) for a complete installation.
- .3 Radiant Ceiling Panels:
- a. The radiant ceiling extrusions shall consist of extruded aluminum with copper tubing of 0.504" (12.8mm) ID mechanically attached to the aluminum face plate. The copper tube shall be held in place by an aluminum saddle which extends more than half way around the diameter of the tube. A non-hardening heat conductive paste shall be placed between the copper tubing and the aluminum face plate. Panels shall weigh no more than 2.15 lb./sq.ft. (10.5 kg./sq. m.) when operating. The use of adhesive and / or clips to attach the copper tube to the extrusion will not be acceptable.
  - b. Panels shall be finished in the manufacturers standard white colour.
  - c. Install panels according to manufacturers recommendations and as follows:
    - i. All interconnecting of radiant panels shall be by the Mechanical Contractor and shall consist of 0.5" (13mm) OD soft copper tubing or manufacturers supplied accessories (factory supplied 360 degree inter-connecting loops, 180 degree return U-bends). Hot water supply piping shall first connect to panel tubing passing closest to the perimeter wall. Multiple panels shall be circuited to ensure serpentine flow over the complete length of the zone. Individual serpentine panel coils connected in series is unacceptable for multiple panel zones.
    - ii. Where applicable, radiant panels shall run continuous from wall-to-wall and shall be field trimmed to length ensuring adequate expansion allowance while maintaining panel end coverage by architectural mouldings. Inactive filler panels will be permitted only where indicated on the drawings.
    - iii. Ceiling support mouldings for radiant panels shall be supplied and installed by the General Contractor. Ensure ceiling openings and wall mouldings are installed according to the radiant panel shop drawings.

- iv. All radiant panels shall be installed by personnel wearing clean white gloves, to avoid soiling of the panel face. Hanger wires for safety restraint shall be installed by the Mechanical Contractor at 4'-0" (1200mm) centers or as recommended by the manufacturer (wires shall be of a type approved by the Architect where exposed).
  - v. Each group or zone of coils shall be pressure tested as described elsewhere in this specification.
  - vi. No installation of finished radiant panels shall begin until all glazing has been completed and all exterior openings closed in.
  - vii. All active panels shall be covered with a minimum of 1" (25mm) thick batt insulation having 0.75 lb. / cubic ft. (12.0 kg. / cubic m.) density. All insulation shall be provided by the Mechanical Contractor.
- d. For model, accessories and performance requirements, refer to Equipment Schedules on the drawings.

### 2.8 Testing and Inspection

- .1 Test hot water heating piping at 1.5 times the system operating pressure or 125 Psig (860 Kpa), whichever is greater for a minimum 4 hour period or as may be necessary to determine if there is leakage. Repair all leaks to the Consultants approval.
- .2 All leaks shall be repaired by remaking the joint. After piping systems have been tested and repaired, repeat tests.
- .3 All equipment / devices which may be damaged by test pressures shall be isolated during testing procedures.
- .4 Lines containing check valves shall have the source of test pressure located on the upstream side.

### 2.9 Approved Products List

- .1 Hydronic Heating Equipment
  - a. Engineered Air
  - b. Sigma
  - c. Rosemex
  - d. Kampmann
- .2 Air Vents
  - a. Crane
  - b. Maid-O-Mist
  - c. Sparco
  - d. Watts
  - e. Taco
  - f. Armstrong
- .3 Pipe Hangers

- 
- a. Taylor Walraven
  - b. Crane
  - c. Unistrut
  - d. Myatt
- .4 Valves and Strainers
- a. Kitz
  - b. Crane
  - c. Watts
  - d. Toyo
  - e. M.A. Stewart
  - f. Apollo
  - g. Mueller
  - h. Victaulic
- .5 Pressure Gauges / Thermometers
- a. Terice
  - b. Dwyer
  - c. Baker
  - d. Taylor
  - e. Ashcroft
  - f. Winters

### **3. HEATING, VENTILATING AND AIR CONDITIONING**

#### **3.1 Ductwork**

- .1 All ductwork shall be G-60 galvanized steel unless noted otherwise, in accordance with ASTM A-653 and A-924. Thickness and fabrication shall be to ASHRAE and SMACNA standards.
- .2 Where noted on the drawings and below, ductwork shall be type T3003H14 aluminum. Thickness and fabrication shall be to ASHRAE and SMACNA standards.
  - a. Dishwasher exhaust system ductwork shall be aluminum.
  - b. Dryer exhaust system ductwork shall be aluminum and shall be assembled without screws or other fasteners which extend into the vent.
- .3 Fittings and joints shall be fabricated and installed to ASHRAE and SMACNA standards. Proprietary duct joints as manufactured by Ductmate Canada Ltd. or approved equal may be used where desired by the Contractor.
- .4 All exposed circular ductwork shall be spiral type as follows:
  - a. Ductwork shall be constructed of Satin Coat steel.
  - b. Duct and fittings shall be constructed in accordance with the latest SMACNA HVAC Duct Construction Standard.
  - c. Straight Duct:

- 
- i. The straight duct shall be constructed with an interlocking 4-ply helical seam that runs the complete length of the duct. The grooved seam shall be located entirely on the outside, resulting in a smooth interior for a low friction loss.
      - ii. The straight duct shall be smooth type (corrugations / grooves to increase rigidity are not required).
    - d. Fittings:
      - i. Fittings shall be standing seam or pressed / stamped type.
      - ii. Fittings shall be '1.5D' type unless not possible due to space restrictions.
    - e. Straight duct sections and fittings shall utilize slip-joint connections. Provide couplings where joining straight duct sections. .
  - .5 Non-metallic flexible ductwork shall be Thermaflex S-LP or approved equal, non-collapsible woven and coated fibre glass fabric permanently bonded to a coated spring steel wire helix. Where flexible ductwork is connected to thermally insulated rigid ductwork, flexible ductwork shall be thermally insulated type, Thermaflex G-KM or approved equal. Flame and smoke developed ratings not to exceed 25 and 50 respectively. Ducts shall comply with ULC, NFPA and SMACNA standards.
  - .6 Maximum length of flexible ductwork shall be 5'-0" (1500mm).
  - .7 All duct runnouts shall have a diameter the same size as the diffuser neck size unless noted otherwise.
  - .8 All rectangular supply / return / exhaust ducts shall connect to main ducts complete with 45 degree entry. This shall include branches serving grilles mounted directly to the duct except that for grilles mounted to exposed spiral duct work a square entry is permitted.
  - .9 All supply / return / exhaust elbow fittings shall have a centreline radius equal to 1.5 times the duct width for rectangular ducts or 1.5 times the diameter for round ducts. Where absolutely not possible due to space constraints, a centreline radius of 1 times the width (or diameter) shall be permitted or square elbows complete with turning vanes shall be permitted.
  - .10 All supply, exhaust and return air ductwork shall be complete with sealed joints as follows:
    - a. Supply, return and exhaust ductwork shall be Seal Class A in accordance with ASHRAE 90.1-2022 and as defined in SMACNA standards (transverse joints / connections, longitudinal seams and duct wall penetrations made airtight with sealing compound).
    - b. Dryer venting shall be Seal Class A as defined in SMACNA standards (transverse joints / connections, longitudinal seams and duct wall penetrations made airtight with sealing compound plus aluminum tape).
    - c. Note that spiral ductwork having a sealing gasket requires no sealing compound.
    - d. Exposed ductwork shall be neatly sealed to the approval of the Consultant, without excess caulking.
  - .11 Provide waterproof ducts for goosenecks and any other exposed exterior ductwork. All seams, joints and connections shall be made water tight with sealing compound.
  - .12 All exposed ductwork located outside of Mechanical / Electrical / Janitor / Storage Rooms shall be manufactured from satin coat steel suitable for painting unless otherwise approved by the Painting Contractor.

- .13 Provide suitable sheet metal angle collar for ductwork running exposed through walls, ceilings or floors. Install collar tight against the wall, ceiling or floor and duct, sized to cover opening.

### 3.2 Kitchen Hood Exhaust Ductwork

- .1 Ducts shall be constructed of and supported by carbon steel of not less than 16 gauge. Unless otherwise noted or permitted by NFPA 96, all seams, joints, penetrations and duct-to-hood collar connections shall have a liquidtight continuous external weld. All duct elbows and offsets shall be radius type constructed to SMACNA standards (turning vanes within ductwork will not be permitted).
- .2 All ducts shall be installed without forming dips and traps that may collect residues.
- .3 Duct-to-duct connections shall be:
- a. Telescoping, bell-type, flange with edge weld or flange with filled weld as described in NFPA 96.
  - b. For telescoping and bell-type connections, the inside duct section shall always be uphill of the outside duct section, the difference between inside dimensions of overlapping sections shall not exceed 0.25" (6.4mm) and the overlap shall not exceed 2" (50mm).
  - c. Butt welded connections will not be permitted.
- .4 Provide access openings for the cleaning and inspection of the interior surfaces of all exhaust ducts and provide access openings at all changes in direction unless otherwise permitted by NFPA 96 . All access openings shall comply with NFPA 96 requirements and shall be approximately as follows:
- a. Openings shall be located on the sides or at the top of the duct. The edge of openings shall be not less than 1.5" (38mm) from all outside edges of the duct or welded seams.
  - b. On horizontal ducts:
    - i. At least one 20"x20" (500x500mm) opening shall be provided for personnel entry. Where this is not possible, smaller openings shall be provided at 12'-0" (3.6m) intervals.
  - c. On vertical ducts:
    - i. Adequate access for cleaning shall be provided on each floor.
  - d. At the hood connection(s) having dampers in the collar, provide an access panel for cleaning / inspection unless dampers are accessible through the hood.
  - e. Access panels shall be of the same material and thickness as the duct.
  - f. Access panels covering the openings shall have a gasket or sealant that is rated for 1500 deg. F. (815 deg. C.) and is greasetight. Fasteners used to secure the access panel to the grease duct shall not pierce the duct wall. Instead, weld a flanged collar to the opening, and attach access panel to collar with fasteners.
  - g. Panels shall be labelled ACCESS PANEL - DO NOT OBSTRUCT.
- .5 All duct connections to the hood and exhaust fan shall comply with NFPA 96 requirements to provide a liquid tight seal.
- .6 All roof exhaust fans shall be mounted with their outlets minimum 40" (1000mm) above the roof and with 10'-0" (3.05m) clearance to adjacent buildings, property lines and air intakes

unless otherwise permitted by NFPA 96. All clearances from fans to combustibles and limited combustibles shall be as specified below for ductwork.

- .7 The hood and ducts shall have a clearance of at least 18" (450mm) to combustibles, 3" (75mm) to limited combustibles and zero clearance to noncombustibles unless otherwise specified in NFPA 96. Reduced clearances will be permitted when materials are protected as specified in NFPA 96 or as noted on the drawings. Refer also to NFPA 96 Materials Classification Schedule on the drawings.
- .8 For exact requirements regarding the installation of the kitchen hood exhaust system, refer to NFPA 96.
- .9 The complete kitchen hood exhaust system shall be field tested to the approval of the Consultant, Owner, and local authority. Perform a smoke test of the exhaust ductwork and any other test requested by the local authority without extra cost.

### 3.3 Turning Vanes

- .1 Factory or shop fabricated single or double thickness to recommendations of SMACNA.

### 3.4 Supports

- .1 All ducts and gas vents shall be adequately supported. Maximum size to be supported by a strap hanger shall be 36" (900mm) wide. All other ducts shall be supported by steel angles complete with threaded rods, locking nuts and washers. Threaded rods shall be sized according to the recommendations of Taylor Walraven to suit the application. Hanger spacing shall comply with SMACNA standards and Gas Code requirements.
- .2 Ducts cannot in any location be supported from the furring or ceiling construction. Also, ducts having areas greater than 1.0 sq. ft. (0.1 sq. m.) cannot in any location be supported from the metal floor / roof deck. Smaller ducts which are permitted to be supported from the metal floor / roof deck shall be fastened to the sides (not bottom) of the flutes and shall be attached with a minimum #10 size screw.
- .3 All pipe and equipment supports shall be as follows:
  - a. Supports shall be Taylor Walraven or approved equal of spacing and type as recommended by manufacturer, in accordance with Code requirements and in accordance with good commercial standards.
  - b. Provide supports to secure equipment, prevent vibration and produce a neat appearance. Design for strength and rigidity to suit loading and services, prevent undue stress to structural members and with provision for vertical adjustment after piping is erected.
  - c. Offset hanger and structural attachments in such a manner that rod is vertical when equipment is at operating temperature and is subject to tensile loading only.
  - d. Adjust hanger rods to equalize load.
  - e. Provide supplementary structural steelwork where structural bearings.
  - f. Where supporting from open web steel joists, attach supports to the approval of the structural engineer and comply with the following:
    - i. Attach supports to the top angle iron section of joists only.
    - ii. Support from panel points only.

- .4 Supports for exposed spiral ductwork shall consist of a steel rod centered over the duct and attached to a continuous band around the duct (sheet metal strips will not be permitted in place of steel rod support).
- .5 All supports for the kitchen hood exhaust ductwork shall be in compliance with the requirements of the fire rated thermal insulation manufacturer.

### 3.5 Roof Curbs

- .1 All curbs for roof mounted exhaust fans, rooftop units, goosenecks, etc. shall be supplied and installed by the Mechanical Contractor.
- .2 Roof curbs shall be galvanized steel with wood nailer strip, turndown flange and shall be capable of supporting the entire unit weight. Curbs may be bolted together on site where required for ease of transporting to site.
- .3 Provide a closed cell curb gasket with adhesive on one side to seal between the ductwork / roof mounted equipment and the top of curb.
- .4 Suitably secure curbs to the roof deck and level according to manufacturer's recommendations. The sides of curbs shall be insulated on the exterior with insulation of the same type and having the same thickness as the new / existing roof insulation.

### 3.6 Duct Access Doors

- .1 Provide duct mounted access doors to service all mechanical equipment requiring maintenance access (including fire dampers, motorized dampers, heating coils, etc.). Provide doors on one or both sides of device as required to permit full service / cleaning. Doors shall be Nailor-Hart series 0800 or approved equal, insulated sandwich construction complete with sheet metal angle frame, 1" (25mm) thick insulation, gaskets and camlocks. Sizing to manufacturer's recommendations to suit application.

### 3.7 Duct Sealant

- .1 Interior duct sealant shall be Bakor Duck-Seal or approved equal having a maximum flame and smoke rating of 25 and 50 respectively. Exterior duct sealant shall be Bakor 530-09 or approved equal having a maximum flame and smoke rating of 25 and 50 respectively.

### 3.8 Rooftop Unit Condensate Drain Piping

- .1 Schedule 40 galvanized steel pipe complete with threaded connections. Provide minimum 4" (100mm) trap seal.
- .2 Provide open standpipe on downstream side of trap according to the rooftop unit manufacturer's recommendations (to permit free flow of condensate and cleaning of trap).

### 3.9 Flexible Duct Connections

- .1 Unless noted otherwise, duct connections to rooftop units, exhaust fans, heat / energy recovery ventilators and make-up air units shall be made using flexible duct connections, Duro-Dyne "Super Metal-Fab" or approved equal having the following features:
  - a. 24 gauge (0.7mm) galvanized steel frame.
  - b. Each frame shall be 3" (75mm) wide and the fabric shall be 6" (150mm) wide.
  - c. Seams: Grip Loc
  - d. Fabric: woven fiberglass complete with a neoprene coating, -40 to 200 deg. F. (-40 to 82 deg. C.) continuous operating temperatures.
  - e. Suitable for pressures from -10" wc. to 15" wc. (-2.5 to 3.7 Kpa) with no tearing or visible separation.
  - f. Airtight and waterproof.
  - g. Designed to meet NFPA 701, 90A and 90B.
  
- .2 Flexible duct connections are not required to serve the following equipment:
  - a. Supply / exhaust fans having capacities less than 150 CFM (70 L/S).
  - b. Kitchen hood exhaust fans.
  - c. Dryer booster fans.

### 3.10 Fire Dampers

- .1 Fire dampers shall be Nailor series D0100 or approved equal (series D0500 for ratings of 3 hrs. or more), curtain type fire dampers **classified for use in Dynamic Air Systems (systems which remain in operation in the event of a fire) as well as suitable for use in Static Air Systems (systems which shut down in the event of a fire)**. Dampers shall be as follows:
  - i. Dampers shall meet the requirements of NFPA 90A and shall be manufactured, tested and labeled in accordance with UL 555 Safety Standard for Fire Dampers - Sixth Edition, June 1999, including Dynamic Closure Test.
  - ii. Dampers shall be classified for dynamic closure against an airflow velocity of 2000 fpm (610 mpm) at 4" (100mm) static pressure differential across closed damper.
  - iii. Each fire damper shall bear a UL 1.5 hour fire resistance rating label in addition to label verifying the airflow and closure pressure ratings as established by the Dynamic Closure Test. Each fire damper shall also be marked with the words For use in dynamic systems. Dampers marked For use in static systems only are not acceptable.
  - iv. Each fire damper shall be complete with a 165 deg. F. (74 deg. C.) UL Listed fusible link.
  - v. Each damper shall include a steel sleeve of appropriate length / gauge and retaining angles on both sides of penetration, field supplied and installed by the Mechanical Contractor.
  - vi. Fire dampers shall be labelled for fire rating to suit building construction at point of installation.
  - vii. Except as otherwise noted, fire damper configuration shall be type A or B for rectangular ductwork (type shall be selected by the Contractor to suit installation) and type CR for round ductwork. Type A fire dampers will not be permitted to be installed in ducts having a minimum dimension of 8" (200mm) or less.

- .2 Where duct sizes exceed available single section damper sizes for D0100 dampers, Nailor series D1200 or approved equal (series D1200-3 for ratings of 3.0 hours or more) airfoil blade type fire dampers may be used. Dampers shall be as follows:
- i. The frame shall be constructed of 16 ga. (1.6mm) galvanized steel hat channel with mitered corners reinforced with die-formed corner gussets for strength.
  - ii. Blades shall be 14 ga. (2.0mm) galvanized steel formed double skin, airfoil design, on 5.5" (138mm) centers. Dampers shall be of opposed blade configuration with an interlocking blade design that provides complete flame and smoke seal under fire conditions at an elevated temperature of 2000 deg. F. (1093 deg. C.) when in the closed position.
  - iii. Blade axles shall be plated steel, double bolted at each end of blade to ensure positive locking connection. Hex or square friction-fit, or press-fit axles are not acceptable.
  - iv. Bearings shall be self-lubricating oilite bronze type.
  - v. Blade linkage shall be zero-maintenance, concealed in frame, out of the airstream.
  - vi. Dampers shall meet the requirements of NFPA 90A and shall be manufactured, tested and labeled in accordance with UL 555 Safety Standard for Fire Dampers - Sixth Edition, June 1999, including Dynamic Closure Test.
  - vii. Dampers shall be classified for dynamic closure against an airflow velocity of 2000 fpm (610 mpm) at 4" (100mm) static pressure differential across closed damper.
  - viii. Each fire damper shall bear a UL 1.5 hour fire resistance rating label (3.0 hour label for D1200-3 dampers) in addition to label verifying the airflow and closure pressure ratings as established by the Dynamic Closure Test. Each fire damper shall also be marked with the words For use in dynamic systems. Dampers marked For use in static systems only are not acceptable.
  - ix. Each fire damper shall be complete with a 165 deg. F. (74 deg. C.) UL Listed fusible link that will cause the damper to close and lock in the closed position by means of an over-center / knee lock linkage for assured closure.
  - x. Each damper shall be supplied with an internal manual quadrant(s) for setting and locking of blades in the desired position.
  - xi. Each damper shall include a steel sleeve of appropriate length / gauge and retaining angles on both sides of penetration, field supplied and installed by the Mechanical Contractor.
  - xii. Fire dampers shall be labeled for fire rating to suit building construction at point of installation.
  - xiii. Fire damper configuration shall be type A or B for rectangular ductwork (type shall be selected by the Contractor to suit installation) and type C for round ductwork.
- .3 Where fire dampers are installed at grilles, dampers shall be Nailor series D0110G or approved equal, dynamic type.
- .4 Install all dampers according to Code requirements and manufacturer's installation instructions.

### 3.11 Smoke Dampers

- .1 Smoke dampers shall be Nailor series 1210 or approved equal constructed as follows:
  - a. Frame shall be constructed of 16 gauge galvanized steel hat channel.
  - b. 14 ga. (2.0) equivalent galvanized steel formed airfoil on 5 1/2" (140) centers. Opposed action.
  - c. Bearings shall be self-lubricating oilite bronze type.
  - d. Concealed in frame. 12 ga. (2.7) plated steel.
  - e. Jamb seals shall be compression type stainless steel. Blade seals shall be silicone
- .2 Dampers shall meet the requirements of NFPA 90A and 92 and shall be classified by UL and labeled as a Class II Leakage Rated smoke damper under UL555S at an elevated temperature of 350°F (177°C).
- .3 Dampers shall be qualified for use in dynamic or static smoke control systems.
- .4 Dampers shall be supplied with factory installed sleeves (optional field supplied sleeves may be supplied where desired by the Trade) of minimum 16" (400mm) length, to be field verified by Trade to suit the wall thickness. Sleeves shall be caulked to UL requirements and shall be 20 gauge through 84" (2100mm) wide, and 18 gauge above 84" (2100mm) wide. Provide type A, B or C sleeve to suit installation.
- .5 Dampers shall be permitted to be installed up to 24" (610mm) away from the plane of the fire separation in accordance with OBC 3.1.8.9A.(2).
- .6 A Belimo or approved equal 120 volt actuator (power open, spring close) shall be installed by the damper manufacturer in the factory and shall have been tested and classified under UL555S with the damper at an elevated temperature of 350°F (177°C). Actuators shall incorporate an OEM internal spring return mechanism. Actuators shall include a factory mounted end switch. External after-market spring mechanisms are not acceptable. Damper and actuator assembly shall be factory cycled a minimum of three times to ensure correct operation.

### 3.12 Motorized Dampers

- .1 For dampers not exposed to outdoor conditions, Tamco series 1000 or approved equal, opposed blade action having the following features:
  - a. Extruded aluminum damper frame shall be 4" (100mm) deep and not less than .080" (2.03mm) thickness.
  - b. Blades shall be of extruded aluminum profiles and complete with EPDM gaskets secured in an integral slot within the extrusion.
  - c. Frame seals shall be of extruded TPE.
  - d. Linkage hardware shall be installed in the frame side and shall be constructed of aluminum and corrosion-resistant, zinc-plated steel, complete with cup-point trunnion screws for slip-proof grip.
  - e. Bearings shall be composed of a celcon inner bearing fixed to a 7/16" (11.1mm) aluminum hexagon blade pin, rotating within a polycarbonate outer bearing inserted in the frame.
  - f. Based on a 48"x48" (1200x1200mm) damper, air leakage shall not exceed 10.3 CFM/sq. ft. (52 L/S/ sq. m.) against 4" (1 Kpa) w.c. differential static pressure.

- g. The pressure drop through a fully open damper shall not exceed .02" (.004 Kpa) w.c. at 1000 FPM (5.08 m/s).
  - h. Dampers shall be made to the sizes indicated on the drawings without blanking off free area.
  - i. Mounting type shall be flanged to duct, installed in duct or square to round type as applicable.
- .2 For dampers exposed to outdoor conditions, Tamco series 9000 BF or approved equal, opposed blade action having the following features:
- a. Extruded aluminum damper frame shall be 4" (100mm) deep, not less than .080" (2.03mm) thickness, with mounting flanges on both sides of the frame.
  - b. The entire frame shall be thermally broken by means of polyurethane resin pockets complete with thermal cuts.
  - c. Blades shall be of extruded aluminum profiles, internally insulated with expanded polyurethane foam and shall be thermally broken. The complete blade shall have an insulating factor of R-2.29 and a temperature index of 55.
  - d. Blade and frame seals shall be of extruded silicone, for reduced air leakage at colder temperatures. Blade and frame seals shall be secured in an integral slot within the aluminum extrusions and shall be mechanically fastened to prevent shrinkage and movement over the life of the damper.
  - e. Bearings shall be composed of a celcon inner bearing fixed to a 7/16" (11.1mm) aluminum hexagon blade pivot pin, rotating within a polycarbonate outer bearing inserted in the frame.
  - f. An adjustable 7/16" (11.1mm) hexagonal drive rod, u-bolt fastener, and hexagonal retaining nuts shall be zinc-plated steel.
  - g. Aluminum and corrosion-resistant zinc plated steel linkage hardware shall be installed in the frame side, complete with cup-point trunnion screws for a slip-proof grip.
  - h. Dampers shall be designed for operation in temperatures ranging from -40 deg. F. (-40 deg. C.) to 212 deg. F. (100 deg. C.).
  - i. Dampers shall be leakage Class 1A at 1" w.c. (0.25 Kpa) static pressure differential. Standard air leakage data shall be certified under the AMCA Certified Ratings Program.
  - j. Dampers shall be opposed blade action.
  - k. Dampers shall be made to the sizes indicated on the drawings without blanking off free area. Mounting type shall be "flanged to duct" only.
  - l. Dampers shall be installed according to the manufacturers installation guidelines.

### 3.13 Manual Dampers

- .1 For spin-in collars, single blade butterfly dampers shall be of same material as duct. Metal construction and damper configuration to recommendations of SMACNA. Balancing dampers shall have handle and hand locking quadrant. Where dampers are installed in thermally insulated ductwork, provide 2" (50mm) stand-off bracket for hand quadrant.
- .2 For round ductwork 20" (500mm) diameter and less, provide single blade butterfly dampers, Nailor model 1890 or approved equal. Dampers shall be constructed and configured to the recommendations of SMACNA. Provide the following construction features:

- 
- i. 22 gauge (0.86mm) galvanized steel frame with roll-formed stiffening beads up to 12" (300mm) diameter, 20 gauge (0.91mm) over 12" (300mm) diameter.
  - ii. 22 gauge (0.86mm) galvanized steel blade up to 12" (300mm) diameter, 20 gauge (1.0mm) over 12" (300mm) diameter.
  - iii. Blade axle / drive shaft shall be 0.25" (6mm) square plated steel.
  - iv. Hand locking quadrant.
  - v. Where dampers are installed in thermally insulated ductwork, provide 2" (50mm) stand-off bracket for hand quadrant.
- .3 For rectangular ductwork, provide single blade dampers for ducts sizes up to 24" x 12" (600x300mm), Nailor model 1870 or approved equal. Dampers shall be constructed and configured to the recommendations of SMACNA. Provide the following construction features:
- i. 18 gauge (1.3mm) galvanized steel frame with structural ribs for maximum strength and low profile for maximum free area.
  - ii. 20 gauge (1.0mm) galvanized steel blades up to 24"x12" (600x300mm) complete with structural ribs for extra strength.
  - iii. Blades shafts shall be 0.25" (6mm) square plated steel complete with a hand locking quadrant.
  - iv. Where dampers are installed in thermally insulated ductwork, provide 2" (50mm) stand-off bracket for hand quadrant.
  - v. For dampers installed in aluminum ductwork, provide aluminum frame and blades with stainless steel linkage, bearings, axles and related hardware.
- .4 For rectangular ductwork, provide multi-blade were duct sizes exceed 24" x 12" (600x300mm), Nailor model 1820 or approved equal. Dampers shall be constructed and configured to the recommendations of SMACNA. Provide the following construction features:
- i. 16 gauge (1.6mm) galvanized steel hat channel frame with die-formed corner gussets.
  - ii. 16 gauge (1.6mm) galvanized steel vee groove design blades on maximum 6" (150mm) centers in opposed configuration.
  - iii. Blade axles shall be 0.5" (13mm) diameter plated steel, double bolted to blades.
  - iv. Bearings shall be 0.5" (13mm) Celcon molded synthetic type
  - v. Plated steel blade linkage shall be concealed type, totally enclosed within the frame and out of airstream.
  - vi. Provide 6" (150mm) long by 0.5" (13mm) diameter lock-on drive shaft on each damper section complete with a hand locking quadrant.
  - vii. Where dampers are installed in thermally insulated ductwork, provide 2" (50mm) stand-off bracket for hand quadrant.
  - viii. For dampers installed in aluminum ductwork, provide stainless steel construction.
- .5 Where manual balancing dampers are installed in exposed locations, the damper operator shall be installed on the top of the duct.

### 3.14 Grilles and Diffusers

- .1 Krueger or approved equal. Refer to Diffuser and Grille Schedule on drawings for model and type.

- .2 All aluminum grilles shall be fastened with stainless steel screws.

### 3.15 Duct Acoustic Insulation

- .1 Johns Manville Linacoustic RC or approved equal flexible duct liner made with glass fibers bonded with a thermosetting resin. The airstream surface shall be protected with a Permacote acrylic coating with a flexible glass cloth reinforcement. A factory applied coating shall be applied to the edges of the liner core.
- .2 Unless noted otherwise on the drawings, provide 0.5" (13mm) thickness having an R value of 2.2 hr.-sq.ft.-deg.F / Btu (0.38 sq.m.-deg.C/W) for all ductwork where indicated on the drawings. NOTE: WHERE ACOUSTIC LINING IS INSTALLED, SIZE OF DUCTWORK IS ACTUAL OUTSIDE DIMENSION OF DUCT.
- .3 All portions of duct designated to receive duct liner shall be completely covered with liner. Transverse joints shall be neatly butted and there shall be no interruptions or gaps. The liner surface designed to be exposed shall face the air stream. Duct liner shall be adhered to the sheet metal with 100% coverage of adhesive and all exposed leading edges and all transverse joints coated with adhesive. The liner shall be additionally secured with weld-on pins which shall compress the duct liner sufficiently to hold it firmly in place.
- .4 Duct liner shall be cut to assure overlapped and compressed longitudinal corner joints. For velocities to 2,500 ft./min. (762 m/min.) the weld-on pins shall start within 3" (75 mm) of the transverse edges of the liner. Space with a maximum separation of 12" (300 mm) around the perimeter of the duct except that pins shall be a maximum of 4" (100mm) from a corner break. Elsewhere they shall be a maximum of 18" (450 mm) o.c.. All transverse edges shall be coated with adhesive.
- .5 All insulation shall be applied according to manufacturer's recommendations.
- .6 All insulation and components shall have maximum flame and smoke spread ratings of 25 and 50 respectively.

### 3.16 Dryer Booster Fans

- .1 Dryer Booster Fans:
- a. Fans shall be Ortech or approved equal having the following features:
  - b. Capable of exhausting air up to 165 deg. F. (75 deg. C.).
  - c. Permanently lubricated, enclosed, external rotor design motor.
  - d. Self-cleaning backward curved impeller.
  - e. Galvanized steel housing with powder-coat finish.
  - f. Integrated pressure sensing switch complete with 18" (450mm) of pressure sensing tubing with mounting grommet (to automatically activate the booster fan when the dryer is energized).
  - g. Galvanized mounting bracket and hardware.
  - h. Inlet and outlet duct connection flanges.
  - i. 5'-6" (1650mm) power cord.
- .2 For model, accessories and performance requirements, refer to Equipment Schedule on the drawings.

---

3.17 Rooftop Fixed Plate Energy Recovery Ventilator

- .1 General
  - a. Packaged Air-to-Air Fixed Plate Energy Recovery Ventilator (ERV).
  - b. ERV must include the following components:
    - i. a fixed plate air-to-air energy recovery core;
    - ii. a fresh air blower;
    - iii. an exhaust air blower;
    - iv. filters ahead the core in both fresh and exhaust air circuits;
    - v. an insulated cabinet for an outdoor installation;
    - vi. sensors and microprocessor controls for an autonomous operation.
  - c. The ERV must be capable of transferring both sensible and latent energy.
  - d. The ERV must be designed to be used as a stand-alone unit or as a component in a dedicated HVAC system or as complete ventilation/HVAC unit.
  - e. The unit must be complete, fully assembled with gauges and controls, ready to be wired.
  
- .2 Quality Assurance
  - a. The fixed plate Energy recovery core must be AHRI certifies for the 1060 standard. Noncertified product will not be considered.
  - b. The unit must be tested as per ANSI/UL 1995 and CAN/CSA C22.2 No. 236, Fourth Edition, October 14, 2011.
  - c. The unit must be ETL certified.
  - d. The insulation shall comply with NFPA 90A requirements for flame spread and smoke generation.
  - e. Unit must be free of fabrication defect and maintain proper operation under normal use for a period of two years from purchasing date.
  - f. Unit must be fully tested before delivery.
  
- .3 Cabinet
  - a. The cabinet must have a double-wall construction with a 1-inch thick fiberglass insulation.
  - b. The floor of the unit must be insulated 1 inch with fiberglass and protected with a 22-ga galvanized steel sheet metal.
  - c. The interior wall must be made of G90 galvanized steel 22 ga.
  - d. The exterior wall of the unit must be made of prepainted steel 22 ga. The paint must be made of a silicone based polyurethane and withstand 150 rubs (back and forth) with methyl ethyl ketone (MEK) when tested as per ASTM-D5402.
  - e. The interior wall must be designed to support the structural loads of the cabinet.
  - f. The structural base of the unit must be constructed with 14-gauge galvanized steel.
  - g. The peripheral base must be equipped with lifting lugs.
  - h. The access doors must be equipped with ¼ turns handles with integrated locks.
  - i. The access doors must be equipped with 180° hinges.
  - j. The cabinet must allow access to all inside components and allow access for maintenance on one side of the unit; no clearance is needed on the back side.
  - k. The cabinet must be constructed in a manner that there are no screw tips inside the unit.

- 
- l. Every joint must be sealed with polyurethane-based high strength elastomeric sealant that contains no solvents or isocyanates.
- .4 Fixed Plate Energy Recovery Core
    - a. The energy recovery section must be of the fixed plates air-to-air type.
    - b. The energy recovery fixed plates core must be made of a cellulose matrix membrane covered with a polymeric layer to recover both sensible and latent energy
    - c. The core must use the Microban™ technology to avoid mold growth on it.
    - d. The fixed plate air-to-air heat/energy recovery core must be easily cleanable.
    - e. The core efficiency must be rated as per AHRI-1060 and certified by AHRI.
  - .5 Fans
    - a. The supply and exhaust fan must be double with double inlet forward curve.
    - b. The bearings must be sealed and permanently lubricated.
    - c. The fans must be dynamically and statically balanced.
    - d. The drive assembly must be with pulley and adjustable sheave mounted on an 11-gauge galvanized steel base.
    - e. The performances of the fans must be tested as per AMCA-210 standard.
  - .6 Motors
    - a. Motors must have an Open enclosure, Drip Proof high efficiency (EPACT), inverter rated 10:1 with a service factor 1.15.
    - b. The motors must be mounted on an adjustable base to adjust the fan belt bending and alignment.
    - c. The fan drive must be by pulley and trapezoidal belt with a fixed pitch driving pulley and a variable pitch driven pulley.
    - d. Motors must be Premium efficiency (when applicable).
  - .7 Filters
    - a. Each air circuit must have 2-inches thick pleated and replaceable filters.
    - b. Filters must be installed ahead the Energy recovery core in both air stream to protect the core against dust and airborne contaminant that may reduce its efficiency.
    - c. Fresh air circuit filters must be MERV8 rated when tested as per ASHRAE 52.2 standard.
    - d. Exhaust air circuit filters must be MERV8 rated when tested as per ASHRAE 52.2 standard.
  - .8 Electrical Wiring
    - a. The unit must have a single point power connection.
    - b. The unit voltage must be 575 V/3  $\Phi$ /60 Hz.
    - c. The unit must be equipped with a non-fused disconnect NEMA 4.
    - d. The electrical data must be as specified on schedule.
  - .9 Frost Control
    - a. Defrost must be controlled with a temperature sensor.

- b. The unit will undergo cycles of exhaust only. The fresh air motor will stop, and fresh air motorized damper will close for a duration depending on the outside air temperature.
  - c. Defrost cycle shall be administered by the Controls Trade.
- .10 Controls
- a. The unit shall be provided with factory installed terminal strip.
  - b. Terminal strip shall include the exhaust fan status and start/stop, supply fan status and start/stop, and dirty filter contacts.
  - c. Unit must be able to provide a 24VAC 20VA power supply for external accessories.
  - d. Every component shall be properly protected against current overload.
  - e. Each motor must have its own magnetic contactor and thermal overload.
- .11 Options
- a. Dirty Filters Contacts
    - i. Each set of filters in the unit must be equipped with an air pressure drop switch that closes when the filters are dirty.
  - b. Phase Loss Detection
    - i. A sensor monitors all three phases of the power supply and stops the unit if a phase is lost.
  - c. Motorized Damper Fresh Air
    - i. Motorized damper on the fresh air duct made of extruded aluminum insulated and activated with an actuator. Dampers must be low leaks and have integrated thermal breaks. Damper shall spring close on failure.
  - d. Motorized Damper Exhaust
    - i. Motorized damper on the exhaust air duct made of extruded aluminum insulated and activated with an actuator. Dampers must be low leaks and have integrated thermal breaks. Damper shall spring close on failure.d
  - e. Roof Curb
    - i. The unit must come with a 24 inches high non-insulated roof curb.
- .12 For model, accessories and performance requirements, refer to Equipment Schedule on the drawings.

### 3.18 Approved Products List

- .1 Manual Dampers
- a. Tamco
  - b. Nailor
  - c. Ruskin
  - d. Controlled Air
  - e. Alumavent
- .2 Fire Dampers and Smoke Dampers
- a. Controlled Air
  - b. Nailor
  - c. Ruskin

- 
- d. Alumavent
- .3 Access Doors
- a. Nailor
  - b. Controlled Air
  - c. Ruskin
- .4 Flexible Connectors
- a. Duro-Dyne
  - b. Dyn-Air
  - c. American Elgen
- .5 Flexible Ductwork
- a. Thermaflex
  - b. Flexmaster
  - c. Wiremold
- .6 Exhaust Fans
- a. Twin City
  - b. Cook
  - c. Greenheck
  - d. PennBarry
- .7 Dryer Booster Fans
- a. Fantech
  - b. Reversomatic
  - c. Ortech
- .8 Diffusers / Grilles
- a. Titus
  - b. E.H. Price
  - c. Krueger
  - d. Nailor
  - e. MetalAire
- .9 Rooftop Units
- a. Daikin
  - b. Valent
  - c. Trane
  - d. Aaon
- .10 NFPA-96 Compliant Kitchen Hood
- a. Spring Air

b. Halton

**END OF SECTION**

---

## **1. GENERAL**

### 1.1 General Requirements

- .1 Refer to the following related sections:
  - a. Division 20 – Mechanical.
  - b. Division 22 – Plumbing.
  - c. Division 23 – HVAC.
  - d. Section 25 90 00 – CONTROL SEQUENCES
- .2 Comply with the conditions of Division 0 and 1.

## **2. BUILDING AUTOMATION SYSTEM (BAS)**

### 2.1 Description of System

- .1 Furnish and install all components, devices and control wiring for a fully integrated energy management and building control system incorporating Direct Digital Control (DDC), and equipment monitoring. The system shall control/monitor HVAC and plumbing equipment and systems as specified in this section. The work shall include but is not limited to the following:
  - a. All necessary hardware, software, control panels, web access modules, control wiring, field devices, installation, documentation and owner training as specified.
  - b. The installed system shall incorporate electronic and digital control devices to perform the control sequences and monitoring outlined herein. Specific control sequence requirements are as detailed elsewhere in this section of the specification.
  - c. Control valves shall be installed in the piping system complete with transitions and unions as required.
  - d. Testing, debugging, calibrating, adjustment, programming and confirmation of total system operation.
- .2 Distech System Integration (SI) Partners
  - a. The fundamental purpose of BAS integration at the WRDSB consist of four primary objectives:
    - i. to maintain continuity of the Central Command Structure (a.k.a. Global/Local)
    - ii. to allow for future expansion of centrally adjusted network variables/parameters
    - iii. to maximize the administrative efficiency in which we can optimize the functionality and performance of the BAS systems inside 125+ buildings.
    - iv. Maintain Web Security of entire BAS Infrastructure.
  - b. Distech BAS SI Partners must incorporate the integration of the WRDSB NIAGARA BAS server as specified in this document. Upgrading or circumventing the functionality of the existing central WRDSB NIAGARA BAS server will not be considered. No unequivocal or irrevocable substitutions of the WRDSB BAS server allowed.
- .3 Central Command Structure: (two servers during transition period to Niagara-based software)
  - a. WRDSB Vista BAS Server
    - i. Update name to VISTA (formerly EC-TACBAS) on the WRDSB network.

- ii. is based on the Lonworks (LNS) Based Interface
- iii. utilizes Remote Network Interfaces (RNI) Ethernet adapters at each site to communicate to the Lonworks network at each site.
- iv. distributes all network variables via the RNI using the LNS protocol and Loytec NIC-IP to each site.
- v. used to administer the TAC Xenta and Lonworks based BAS devices with the Echelon Lonmaker Network configuration tool, Schneider Electric TAC Vista System Plug-in Tool, and Schneider TAC Menta programming software.
- b. WRDSB Niagara BAS Server
  - i. Update name to NIAGARA (formerly EC-TACBAS-T) on the WRDSB network
  - ii. is based on the Niagara N4-based Distech EC-NET server software to administer the EC-BOS networking devices at each site
  - iii. utilizes Niagara N4-based Distech EC-BOS networking servers complete with adapters at each site to communicate to the BACnet and Lonworks (where applicable) network at each site.
  - iv. distributes all network variables via the Tridium Niagara FOX protocol to each site
  - v. used to administer the Distech BACnet and Lonworks (where applicable) based BAS devices with the Distech GFX programming/controller configuration and Tridium Niagara WorkBench software
  - vi. utilizes Baudrate Schneider Electric TAC driver software (where applicable) to support the Lon-based TAC Xenta Controllers.

#### .4 Network Variables

- a. Over 30 network variables (as detailed in Appendix I) are distributed from the central WRDSB BAS server to all 125 sites at varying intervals:
  - i. for the purpose of zone temperature setpoint adjustment
  - ii. to place lockouts on heating/cooling systems in response to changing seasonal conditions
  - iii. to manage setpoints for night setback heating and cooling modes
  - iv. to manage minimum outside air setpoints for ventilation requirements
  - v. to adjust the beginning and end of heating season
  - vi. to manage boiler water temperature setpoint outdoor reset parameters
  - vii. to set the morning warmup and night setback offset for boiler water temperature.
  - viii. to place lockouts on ventilation based on building use requirements.
  - ix. to place restrictions on ventilation based on humidity for additional energy savings measures.
  - x. to distribute humidity information from one of the three WRDSB humidity averaged zones
  - xi. to distribute the central holiday schedule for setback mode operation
  - xii. for Outdoor Lighting Astroclock Control adjustments to sundown and sunset times
  - xiii. for the purpose of after-hours alarms and troubleshooting
  - xiv. a dashboard is used at the central server to provide a user interface for all the variables and corresponding time/calendar schedules used in the BAS system.
  - xv. a central alarm display is used to capture all incoming BAS alarms from each site.

- .5 Quality Assurance
  - a. The system components shall be listed by Underwriters Laboratories Inc. and Canadian Standards Association.
  - b. The system control products shall be stored and handled according to manufacturer's recommendations.
  - c. The work shall be performed by skilled technicians all of whom shall be properly trained and qualified for this work.
  
- .6 Approved vendors:
  - a. Energy Controls and Mechanical Services
    - i. Contact - Jasmin McCaskie [jasmin@energycontrols.ca](mailto:jasmin@energycontrols.ca)
    - ii. 519-893-2638
    - iii. [energycontrols.ca](http://energycontrols.ca)
  - b. Ingenuity Controls
    - i. Contact - Peter Rochus [prochus@ingenuitycontrols.com](mailto:prochus@ingenuitycontrols.com)
    - ii. 226-599-0470
    - iii. [ingenuitycontrols.com](http://ingenuitycontrols.com)
  - c. Touchstone Building Technologies
    - i. Contact - Brent Divell [bdivell@touchstonebti.ca](mailto:bdivell@touchstonebti.ca)
    - ii. 519 997-2792
    - iii. [www.touchstonebti.ca](http://www.touchstonebti.ca)

## 2.2 Products

- .1 Hardware requirements:
  - a. LON board inside Distech EC-BOS: Installed on site, interfaces between site BAS system, Distech Lonworks Controller and Loytec NIC-IP.
  - b. Loytec NIC-IP RNI: Installed at each site, interfaces between site BAS system and WRDSB NIAGARA server via Ethernet and Lonworks networks.
  - c. a LON-based Distech controller: Must be current version. Installed on site, holds the network variables for use by both the WRDSB NIAGARA server and the site BAS system, and also the switching logic between local and global variable selection.
  - d. Licensing for LON board, Baudrate Schneider TAC Xenta driver for the Distech EC-BOS: Allows access to TAC Xenta controllers points, time schedules and alarms for use in the EC-BOS. Licensing confirmation of LON boards, Schneider TAC Xenta Driver, current Distech BAS SI Partner confirmation as a minimum.
  - e. Distech BACnet MS/TP based controllers are accepted for use with all the remaining systems.
  - f. WRDSB Ethernet Drops: Installed on site, to be co-ordinated with WRDSB IT department, fixed IP address to be assigned by IT.
  - g. All existing functioning BAS devices within each of the 125+ WRDSB buildings including but not limited to Lonworks, BACnet controllers as well as other field controls including sensors, valve or damper actuators, VFD drives, chiller systems, unit vents, air handlers, accessories or others, shall remain integrated. Approaches that require the replacement of existing functioning BAS devices other than the required LAN interfaces for proper integration (EC-BOS / NIC-IP) will not be considered.

- .2 Software requirements:
  - a. Loytec Lconfig: Used as setup tool to configure IP address on the Loytec NI-IP for use on WRDSB Ethernet network.
  - b. Distech gfx: Used as setup tool to program the Distech Lonworks controller to accept the network variables.
  - c. Distech Workbench N4: Used as a setup tool for the Distech EC-BOS
- .3 The system shall integrate the operation of intelligent building management controllers distributed into the network.
- .4 Provide web based access. Two ethernet connections for communication shall be provided by the Electrical Trade.
- .5 The DDC system shall be generally comprised of the following devices to achieve the control functions described in this section:
  - a. Distech 200, 300, 400 and 600 series programmable controllers.
  - b. Distech input/output programmable controllers.
  - c. Network repeaters as required by network lengths.
  - d. Control relays.
  - e. Control dampers and valves.
  - f. Sensors, actuators and other input/output devices.
- .6 Controllers shall execute the application programs, calculations, and commands to provide the control function specified for that unit. Each controller shall include its own micro-computer controller, power supply, input/output modules, termination modules and real time clock.
- .7 Controllers shall be capable of full control functionality and alarm reporting independently or as a part of the DDC network.
- .8 The system shall be stored in flash ram so no batteries are required.
- .9 Each control device shall be modular and expandable to provide additional inputs and outputs and control functionality for that device.
- .10 Each controller shall be able to transfer and receive data via the network for performance of control functions.
- .11 The system shall be modular, permitting expansion by adding hardware and software without changes in communication or processing equipment.
- .12 The controllers shall monitor the status of all overrides and include this information in logs and summaries to inform the operator that automatic control has been inhibited.
- .13 Controllers shall continuously perform self-diagnostics, communication diagnosis and diagnosis of all subsidiary equipment and provide both local and remote annunciation of any component failures.

- 
- .14 Controllers shall activate an orderly shutdown of their operation in the event of loss of normal electrical power. Non-volatile memory shall be incorporated for all controller configuration data. The controllers shall automatically resume full operation without manual intervention.
- .15 The controllers shall have sufficient memory to support their own operating system and data bases including:
- a. Control processes.
  - b. Energy management applications.
  - c. Alarm management.
  - d. Trend data.
  - e. Operator input/output.
  - f. Remote communications.
  - g. Manual override monitoring.
- .16 Controllers shall incorporate the following software features:
- a. Energy management:
    - i. Time of day scheduling.
    - ii. Calendar based scheduling.
    - iii. Holiday scheduling.
    - iv. Optimal start and stop.
    - v. Demand limiting.
    - vi. Heating/cooling interlock.
  - b. Alarm management:
    - i. Alarm management shall be provided to monitor, buffer and direct alarm reports to operator devices and memory files. The controllers shall perform alarm analysis and filtering to minimize operator interruptions due to non-critical alarms, minimize network traffic and prevent alarms from being lost.
    - ii. All alarm or point change reports shall include the points' English language description and the time and date of occurrence.
    - iii. The user shall be able to define the specific reaction for each point, the priority level (three in total) and ability to inhibit alarm reporting for each point.
    - iv. The user shall be able to define conditions under which point changes need to be acknowledged by an operator and logged for analysis at a later date.
    - v. The user shall be able to print, display or store a unique sixty character alarm message to more fully describe the alarm condition or direct operator response. The message shall be customizable to describe each individual alarm.
    - vi. In web access applications, only critical alarms shall initiate a call to a remote operator device, otherwise call activity shall be minimized by time stamping and saving reports until a manual request is received or until the buffer space (minimum fifty alarms) is full.
  - c. Trend logs:
    - i. Controllers shall provide an automatic roll-over trend log, which stores records up to an operator-selected number at an operator-selected sampling rate and then overwrites the oldest record with each new record.
    - ii. Sample intervals shall be from one minute to twenty-four hours.
    - iii. Provide graphical and tabular displays.
  - d. Runtime totalization:

- 
- i. The controllers shall automatically accumulate and store runtime hours for binary points with a sampling resolution of one minute. The user shall have the ability to define a warning limit to trigger maintenance or user-defined messages.
    - e. Event totalization:
      - i. Controllers shall have the ability to count events (such as on/off) and store up to ten million events before reset with a user-defined limit used to trigger a user-defined message.
    - f. Custom programming:
      - i. The controllers shall permit user defined custom control processes based on:
        - 1) Any system measured data or status.
        - 2) Any calculated data.
        - 3) Any results from other processes.
        - 4) Boolean logic.
    - g. The custom processes may be triggered by:
      - i. Time-of-day.
      - ii. Calendar date.
      - iii. Events (point, alarm, etc.).
  - .17 The control strategy for each control loop shall be performed by software within the controller. The sequence of events required for each control loop is described for each system in the control sequence.
  - .18 Outdoor air temperature indication shall be available at each controller as an integral part of the control strategies for that controller. Should the network transmission of the common outdoor air temperature (or any other common value) fail, then each controller shall use the last good value received.
  - .19 Controls and Requirements for VVT Systems
    - a. Where VVT controls are specified, units are to operate as part of a variable volume/variable temperature system complete with all necessary controls including zone dampers, temperature sensors and static pressure sensor probes. A bypass damper will not be required for this project, rather fan speed shall be modulated to maintain duct static pressure.
    - b. There shall be no zone controllers for the room control. Control shall be from a designated programmable controller for each air handling unit to ensure information transfer is fast enough to react to the changes in the environment.
    - c. The VVT control system shall include but not be limited to individual DDC room/zone sensors, corresponding zone dampers, connecting communication network, all required duct sensors, all required relays and other required control components and algorithms for complete control of the HVAC system according to the sequence of operation.
    - d. Each VVT system shall be capable of operating as a stand alone system. Note that each VVT rooftop unit shall have its own designated controller that controls all zones directly in order to keep information exchange quicker and more efficient.
  - .20 Control Panels

- a. Control panels shall be fully enclosed cabinets with all steel construction. Cabinets shall have a hinged door with locking latch or bolt-on cover plate. All cabinet locks shall be common keyed. Cabinets shall be finished with two coats of paint.

.21 Temperature Sensors

- a. Provide thermistor temperature sensors, not requiring transmitters, to measure temperature.
- b. Accuracy shall be +/-0.2°C from 0 to 70°C.
- c. Space sensors in occupied areas shall be Greystone TE200 series, type AE or equal having an integral push button for unoccupied override and an integral slider to adjust set point (LED display not required).
- d. In corridors and where noted on the drawings, provide stainless steel plate type sensors (push button override and LED display not required), Greystone TE200 series, type AS or equal.
- e. Duct temperature sensors shall be Greystone TE200 series, type B or equal having a stainless steel probe length to suit application and ABS enclosure. Duct averaging temperature sensors shall be Greystone TE200 series, type FD or equal having an element length to suit application, copper probe and ABS enclosure.
- f. Outdoor temperature sensors shall be Greystone TE200 series, type F or equal having an ABS gasketed cover. A thermal radiation cover shall limit the sensor to solar radiation exposure.

.22 Humidity Sensors

- a. Sensors shall have 0-100% RH operating range, 0.01% RH resolution, +/- 0.8% RH hysteresis at 25°C (77°F) and 8 second response time.
- b. Space sensors shall be Greystone HRC series room humidity transmitter or equal complete with +/- 2% accuracy and 0°C to 50°C (32°F to 122°F) ambient temperature operating range.
- c. Duct mounted sensors shall be Gerystone HSDT series duct humidity transmitter or equal complete with stainless steel probe length to suit application, ABS enclosure, +/- 2% accuracy and -40°C to 60°C (-40°F to 140°F) ambient temperature operating range.

.23 Carbon Dioxide Sensors

- a. Sensors shall Greystone CDD series or equal having the following features:
  - i. 0-2000 ppm factory default detection range, field adjustable.
  - ii. Non-dispersive infrared sensing element with self-calibration algorithm.
  - iii. Guaranteed five year calibration interval.
  - iv. Powered by either AC or DC source.
  - v. Accuracy: within 50 ppm or 3% of reading (whichever is greater).
  - vi. Operating humidity range: 0-95% RH.
  - vii. Operating temperature range: 0 to 50°C or greater.
  - viii. Stability: less than 2% full scale in 15 years.
  - ix. Response time: less than 2 minutes for 90% step change.
- b. Duct mounted sensors shall be complete with ABS enclosure complete with sampling tube.

.24 Water Control Valves

- a. Heating and cooling control valves shall be Belimo CCV series characterized ball valves, complete with chrome plated brass trim and NPT female pipe connections. Radiation valves shall be complete with non-spring return modulating actuators. Control valves for coils heating a portion of outdoor air shall have spring return modulating actuators.
- b. Control valves shall be sized to provide approximately one half the circuit branch pressure drop to obtain good modulation control but they shall be no smaller than two pipe sizes less than the pipe they are installed in.

.25 Motorized Damper Actuators

- a. Belimo or approved equal as follows:
  - i. Modulation proportional control (2-10VDC / 4-20mA with 500 ohm resistor)
    - 1) Model LF24-MFT(-S) US, 24 volt for dampers up to 6 sq. ft. (0.56 sq. m.).
    - 2) All actuators shall be direct coupled, spring return.
  - ii. Where required by damper size, provide multiple actuators to serve one damper.
  - iii. Provide all accessories required for mounting and balancing, including angle of rotation limiter where required, and end switches where required by control configuration.
- b. Provide damper actuators where indicated on the floor plan, details, equipment schedules or control sequences.

.26 Freezestats

- a. Freezestats shall be complete with a vapour filled 20 foot bulb and 4 foot capillary. Wire freezestats to shut down the respective fans should temperature over any 12 in of sensor length drop below the adjustable setpoint (2°C). Freezestats shall have manual resets.
- b. Provide freezestats where indicated on the floor plan, details, equipment schedules or control sequences.

2.3 Execution

.1 Installation

- a. All controllers and components in the system and on the network shall be installed according to manufacturer recommendations, general installation standards for digital controls and in accordance with the approved shop drawings.
- b. Locate room sensors in the locations shown on the mechanical drawings. All sensors shall be mounted at barrier free height (3'-11" above finished floor).
- c. All control components for off site system access shall be located where noted on the drawings. The Electrical Trade shall provide all required connections / cabling for off site access to the web access components.
- d. All programmable controllers, web access components, relays and other control components shall be located within control panels. Control panels shall be wall mounted and shall be located within suspended ceiling spaces or other locations approved by the Consultant.

- 
- e. The supply of all motorized temperature control dampers complete with actuators shall be by this section, except for dampers and actuators supplied with packaged air handlers.  
The supply of all automatic control valves shall be by This Section.
- .2 Security and serviceability:
- a. Supply username and password.
  - b. Source programming software tools with never expiring licenses
  - c. Source files and databases for all BAS controllers, networking hardware to be able to network, initialize and replace BAS controllers.
  - d. Remote access to school BAS system will not be via VPN or similar method. It will be a managed firewall when available. WRDSB IT firewall and networking rules will need to be followed when integrating the BAS system to the WRDSB NIAGARA BAS Server.
- .3 Reporting requirements:
- a. Network Transfer Diagram: List in a matrix format, all Distech BAS controllers and associated the network variables, indicating the source and destination for each network variable.
  - b. Version Control: Maintain a variable for version number for each Distech BAS controller's software with a description of what changes and updates to the controller software were made, initialled, and dated by the programmer in the source code of the controller.
  - c. Graphical User Interface:
    - i. MAIN graphic: Display all the global network variables, the adjustable local network variables, the adjustable local/global mode switch and the actual network variables in current use, which are actually sent to all the controllers on the local BAS network. Refer to attached sample graphic.
    - ii. SYSTEMS graphics (e.g., AC1, AHU1, RTU3): Indicate the current status of the heating enable, cooling enable, adjustable Holiday Exemption flag, final zone setpoint, Minimum Outside Damper position, Maximum Outside Damper position, Minimum Outside Air Schedule status. Night setback heating and cooling setpoints.
    - iii. MAIN graphic: A link to a notepad file application where an operator can maintain a running day and timestamp in logbook format for any changes/adjustments made to the system, noting any issues that may arise.
- .4 Implementation:
- a. Chain of Data Custody Sequence:
    - i. Network Variables/Parameters are written to the Distech Lonworks Controller by the WRDSB NIAGARA server via the Loytec NIC-IP adapter.
    - ii. The Distech EC-BOS reads the network variables and then stored on the Lon controller and then distributes them to each controller on the local BAS network for use in its sequence of operations.
    - iii. These network variables are to have a parallel set of local network variables stored in the Distech EC-BOS to be used in the local mode. The local mode when selected will transfer the use of the local network variables from the Distech EC-BOS to each controller on the local BAS network instead of the global network variables written to it by the WRDSB EC-TACBAS server.

- iv. The local/global mode switch will be adjustable by the WRDSB NIAGARA server and shown on the main page graphic also adjustable by the operator.
- b. Data Functionality and Persistence:
  - i. All network variables/parameters must be backed up into non-volatile RAM so that the network variables are automatically restored after a reboot/cold start.
  - ii. Local/Global Mode Flag to be read/writeable from the WRDSB NIAGARA Server.
  - iii. Critical Alarms reported back to WRDSB NIAGARA server.
  - iv. If site is designated to have an outdoor humidity sensor, the real time value is to be sent back to the WRDSB EC-TACBAS server.
- c. Overview:
  - i. Service office within 1 hour of all WRDSB Facilities during school hours and after hours.
  - ii. Written confirmation of Distech SI partnership for WRDSB territory.
  - iii. Written confirmation of Schneider/TAC Xenta License for NIAGARA Server for WRDSB territory.
- d. Sample:
  - i. Typical MAIN graphic for each site representing the expected functionality and data representation of the local/global system:

**LEGEND**

- 0.0 °C Adjustable Setpoint
- 0.0 °C Calculated Value
- 0.0 °C Measurement

**Multi-Zone 1**

**Multi-Zone 2**

**Multi-Zone 5**

**AC 1 (Office)**

**HV 1 (Gym)**

**Floor Plan**

**Exterior Lighting**

Sunrise  Sunset  Sunrise/Sunset

Lights off  after sunrise

Lights on  before sunset

Lights

**Domestic Cold Water**

Flush valve

**Outside Air Temp**

**Fire Alarm**

**Ventilation Lockout**

**Critical Alarm**

Lowest Space Temperature

Setpoint

Reset

**Electric Heating**

Entrance Vestibules

OAT Enable Setpoints

Occupied

Unoccupied

Outdoor Air Humidity

Free Cooling Setpoint

Free Cooling Max

Status	OAT Heating Enable	OAT Cooling Enable	Zone Setback Heating	Zone Setback Cooling	Zone Setpoint Adjust	Holiday Schedule	MinOA Schedule
Local	Disabled	Disabled	0.0 °C	0.0 °C	0.0 °C	Holiday	Disabled
Global	0.0 °C	0.0 °C	0.0 °C	0.0 °C	0.0 °C	Holiday	Disabled
Actual	0.0 °C	0.0 °C	0.0 °C	0.0 °C	0.0 °C	Normal	Enabled

e. From Remote Access PC to WRDSB BAS Server to Site – General Architecture:

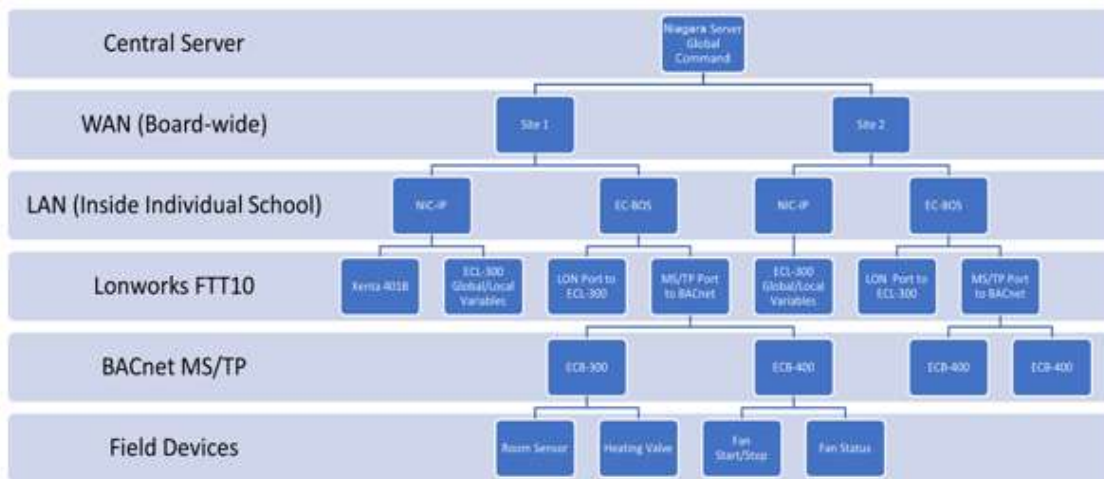
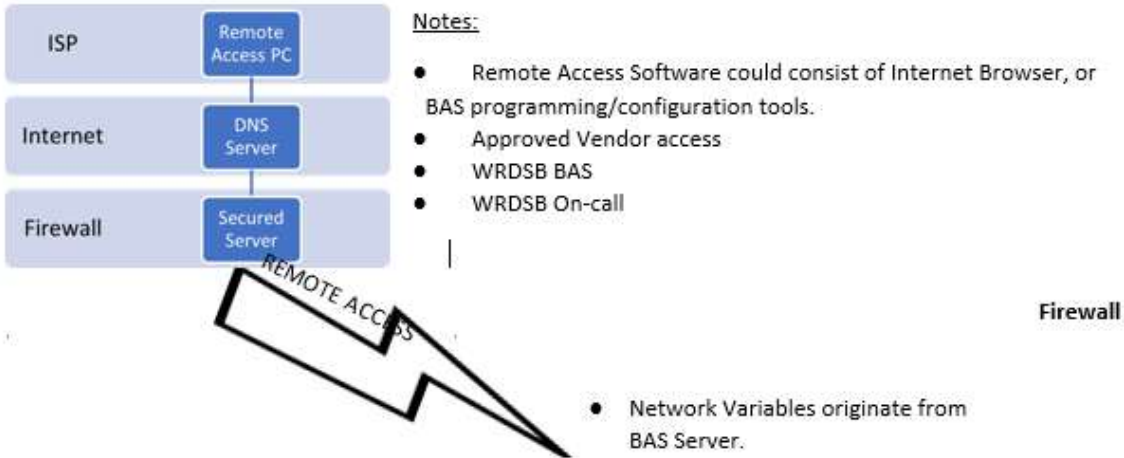

- Network Variables are received at each site via the NIC-IP and onto the Distech ECL-300 or TAC Xenta 401B Controller and distributed for use at each BAS controller by the EC-BOS.

- .5 All carbon dioxide levels which are measured by the carbon dioxide sensors shall be made available to the Owner in the form of trend logs. Record readings at 10 minute intervals and keep them for at least 30 days.
- .6 Freezestats shall be installed so that their sensing element runs horizontally across the coil face (not diagonally) with no more than 12" vertical drops at the outside coil frame. The full face of the coil shall be covered with no horizontal runs being more than 12" apart. The top and bottom horizontal run shall be within 6" of the coil frame. If more than one freezestat is required they shall be wired in series in order to detect a low temperature in portion of the

coil. The sensing elements shall be firmly secured in place to avoid vibration without added air restriction.

.7 System Start-up and Acceptance

- a. Upon completion of installation, test, adjust and calibrate controls provided under this Section.
- b. On system completion, a demonstration of complete system operation shall be made to the Owner's authorized representative and Consultant.
- c. The Consultant shall verify through the Owner's representatives that the entire system is complete and operating to the satisfaction of the Owner before final acceptance is approved.

.8 Close-out Documentation

- a. Provide master schedule of all BAS controlled mechanical equipment affected by work indicating equipment tag and brief description. Master equipment schedule shall be expanded in future projects.
- b. Demonstrate full functionality of the integration from the WRDSB server altering the settings on each of the BAS controllers on site.
- c. Database files: to be backed up and given to WRDSB facilities on USB drive.
  - i. Loytec NIC-IP: Configuration File
  - ii. Distech EC-BOS with Lonworks board and 5-year software updates license: database file
  - iii. Distech Lonworks controller: controller program file
  - iv. Menta: controller program file for the existing TAC Xenta controllers (supplied by WRDSB to integrator)
- d. Complete and submit WRDSB commissioning sheets for all equipment (new and existing) upgraded to BAS control as part of this project.
- e. Refer to Division 20 for additional requirements.

.9 Training

- a. The Controls Trade shall provide competent instructors to give full instruction to designated personnel in the adjustment, operation and maintenance of the system installed rather than a general training course. Instructors shall be thoroughly familiar with all aspects of the subject matter they are to teach. All training shall be held during normal work hours of 8:00 a.m. to 4:30 p.m. weekdays as follows:
- b. Provide 4 hours of training for Owner's operating personnel. Training shall include:
  - i. Explanation of drawings, operations and maintenance manuals.
  - ii. Explanation of web access program.
  - iii. Explanation of adjustment procedures.
  - iv. Trend analysis.

.10 Identification

- a. Provide system identification and provide nameplates identifying the following (nameplates shall be keyed to the wiring diagrams):
  - i. Duct mounted sensors.
  - ii. Control panels (identify as to equipment / systems controlled). Each panel shall include an as-built drawing showing all the connected control points.

.11 Testing and Balancing

- a. During the system testing and balancing by the Balancing Trade, demonstrate the operation of all controls. During balancing procedures, set controls to a fixed mode (bypass damper locked fully closed and all zone dampers locked fully open) to prevent any changes during the balancing procedure.
- b. To ensure excessive noise is not generated by the VVT systems, the following shall be performed:
  - i. For each VVT system, the Balancing Trade shall measure the static pressure in the main duct using a manometer when the system has been stabilized (all zone dampers are full open and the bypass damper is full closed). This information shall be given to the Controls Trade for verification that the VVT system is properly calibrated.
  - ii. For each VVT system, 10% of the dampers shall be set to the full open position and 90% shall be set at their minimum position (fully closed). When operating with these damper positions, the static pressure in the main duct shall again be measured by the Balancing Trade using a manometer to ensure it remains at the value measured when in the stabilized mode. This information shall be given to the Controls Trade for verification that the VVT system is operating correctly and is properly calibrated.

.12 Electrical Wiring

- a. Control transformers for the building automation systems shall be supplied and wired by the Controls Trade from 120 V power sources in junction boxes (at least one at each end of each floor accessible above ceiling tile in a corridor). All low voltage wiring (below 50 V) to the building automation systems shall be by the Controls Trade.
- b. All wiring shall be installed to the standards specified in the Electrical Division.
- c. Use Echelon recommended orange jacket cable for all network wiring.
- d. Run all wiring in EMT conduit where exposed, where running within concrete block walls and where required by the Ontario Electrical Code (conduit supplied and installed by the Controls Trade). Plenum rated cable shall be used in return air ceiling plenums.
- e. Where wiring runs through corridor suspended ceiling spaces, run in wall hooks where possible. The wall hooks shall be provided by the Electrical Trade where indicated on the electrical drawings.
- f. Control relays necessary for BAS operation shall be provided by the Controls Trade but all contactors and their power supplies handling power wiring to the equipment shall be by the Electrical Trade.

.13 General Requirements for VVT Systems

- a. Each VVT system shall be capable of maintaining an independent setback schedule. If any over-ride pushbutton in the associated system is activated, the complete VVT system shall reset to occupied mode for a pre-set time period. At the end of the override time period, setback mode will resume.
- b. Each zone thermostat shall be capable of maintaining independent comfort setpoints, adjustable by the zone occupants. The upper and lower limits of the permissible setpoint range shall be adjustable by the operator.

- c. When the HVAC unit is not in the heating or the cooling mode, the system shall go to ventilation mode. Ventilation mode is automatically sequenced every 20 minutes to avoid stale air in the space. The duration of ventilation mode is 5 minutes, after which the system resumes heating / cooling mode as required.
- d. Zone damper control shall be proportional modulation, not two- position control. Each zone thermostat shall be capable of initiating a heating or cooling mode. Averaging zone systems are not acceptable.
- e. The pressure control system must display duct static pressure and modulate supply and return fan speed to maintain the desired system static pressure. During changeover from heating to cooling or cooling to heating the bypass controller will take control of all dampers in order to purge the duct system of extreme temperature air. Systems that use a time delay during system mode changeover are not acceptable.

---

2.4 Appendix: WRDSB BAS Network Variables

- .1 Globally Distributed Variables from Central BAS Server to Each Site: Each controller on the BAS network on each site will use the following network variables/parameters to integrate into their sequence of operations.
  
- .2 For all Air Handling/Rooftop/Unit Vent Systems:
  - a. Heating Outside Air Temperature Enable
  - b. Cooling Outside Air Temperature Enable
  - c. Zone Temperature Night Setback Heating Temperature Setpoint
  - d. Zone Temperature Night Setback Cooling Temperature Setpoint
  - e. Zone Temperature Setpoint Adjust
  - f. Holiday Scheduling
  - g. Minimum Outside Air Enable Schedule (Zone 1)
  - h. Minimum Outside Air Setpoint (Zone 1)
  - i. Minimum Outside Air Setpoint (Zone 2)
  - j. Minimum Outside Air Setpoint (Zone 3)
  - k. Minimum Outside Air Setpoint (Zone 4)
  - l. Outdoor Air Humidity (Zone 1 calculated average from 3 local sites)
  - m. Outdoor Air Humidity (Zone 2 calculated average from 3 local sites)
  - n. Outdoor Air Humidity (Zone 3 calculated average from 3 local sites)
  - o. Outdoor Air Humidity Maximum Damper Position (Zone 1 Free Cooling Maximum)
  - p. Outdoor Air Humidity Maximum Damper Position (Zone 2 Free Cooling Maximum)
  - q. Outdoor Air Humidity Maximum Damper Position (Zone 3 Free Cooling Maximum)
  - r. Outdoor Air Humidity Maximum Damper Position (Zone 4 Free Cooling Maximum)
  - s. Free Cooling Maximum Mode (Zone 1)
  - t. Free Cooling Maximum Mode (Zone 2)
  - u. Free Cooling Maximum Mode (Zone 3)
  - v. Free Cooling Maximum Mode (Zone 4)
  
- .3 For Outdoor Lighting Astroclock Control:
  - a. Lights Off After Sunrise Offset (in minutes) Area 1
  - b. Lights Off After Sunrise Offset (in minutes) Area 2
  - c. Lights Off After Sunrise Offset (in minutes) Area 3
  - d. Lights Off After Sunrise Offset (in minutes) Area 4
  - e. Lights On Before Sunset (in minutes) Area 1
  - f. Lights On Before Sunset (in minutes) Area 2
  - g. Lights On Before Sunset (in minutes) Area 3
  - h. Lights On Before Sunset (in minutes) Area 4
  
- .4 For Boiler Systems:
  - a. Boiler Systems Area 1:
    - i. Outside Air Temperature 1
    - ii. Hot Water Temperature High Setpoint
    - iii. Outside Air Temperature 2
    - iv. Hot Water Temperature High Setpoint
    - v. Morning Warmup Hot Water Temperature Offset
    - vi. Night Setback Hot Water Temperature Offset

- 
- vii. Gas and Boiler Systems Heating Enable/Disable Dates (4 variables):
        - 1) Heating On Month
        - 2) Heating On Day
        - 3) Heating Off Month
        - 4) Heating Off Day
    - b. Boiler Systems Area 2:
      - i. Outside Air Temperature 1
      - ii. Hot Water Temperature High Setpoint
      - iii. Outside Air Temperature 2
      - iv. Hot Water Temperature High Setpoint
      - v. Morning Warmup Hot Water Temperature Offset
      - vi. Night Setback Hot Water Temperature Offset
      - vii. Gas and Boiler Systems Heating Enable/Disable Dates (4 variables):
        - 1) Heating On Month
        - 2) Heating On Day
        - 3) Heating Off Month
        - 4) Heating Off Day
    - c. Boiler Systems Area 3:
      - i. Outside Air Temperature 1
      - ii. Hot Water Temperature High Setpoint
      - iii. Outside Air Temperature 2
      - iv. Hot Water Temperature High Setpoint
      - v. Morning Warmup Hot Water Temperature Offset
      - vi. Night Setback Hot Water Temperature Offset
      - vii. Gas and Boiler Systems Heating Enable/Disable Dates (4 variables):
        - 1) Heating On Month
        - 2) Heating On Day
        - 3) Heating Off Month
        - 4) Heating Off Day
    - d. Boiler Systems Area 4:
      - i. Outside Air Temperature 1
      - ii. Hot Water Temperature High Setpoint
      - iii. Outside Air Temperature 2
      - iv. Hot Water Temperature High Setpoint
      - v. Morning Warmup Hot Water Temperature Offset
      - vi. Night Setback Hot Water Temperature Offset
      - vii. Gas and Boiler Systems Heating Enable/Disable Dates (4 variables):
        - 1) Heating On Month
        - 2) Heating On Day
        - 3) Heating Off Month
        - 4) Heating Off Day
- .5 Additional Parameters used to calculate final values for distribution from Central Server:
- a. Winter Outside Air Temperature Heating Enable Setpoint
  - b. Summer Outside Air Temperature Heating Enable Setpoint
  - c. Summer Winter Heating Schedule
  - d. Winter Outside Air Temperature Cooling Enable Setpoint
  - e. Summer Outside Air Temperature Cooling Enable Setpoint
  - f. Summer Winter Cooling Enable Schedule
  - g. Normal Night Setback Temperature Heating Enable Setpoint

- 
- h. Economy Night Setback Temperature Heating Enable Setpoint Calculated
  - i. Comfort/Economy Night Setback Heating Schedule
  - j. Outside Air Low Reset for Economy Night Setback Reset Heating Setpoint
  - k. Night Setback Low for Economy Night Setback Reset Heating Setpoint
  - l. Outdoor Air High Reset for Economy Night Setback Reset Heating Setpoint
  - m. Night Setback High for Economy Night Setback Reset Heating Setpoint
  - n. Normal Night Setback Temperature Cooling Enable Setpoint
  - o. Economy Night Setback Temperature Cooling Enable Setpoint Calculated
  - p. Comfort/Economy Night Setback Cooling Schedule
  - q. Normal Setpoint Adjust
  - r. Economy mode Setpoint Adjust
  - s. Comfort Economy Setpoint Adjust Schedule
  - t. Minimum Outside Air Damper Position Setpoint Schedule to Send Area 1
  - u. Minimum Outside Air Damper Position Setpoint Schedule to Send Area 2
  - v. Minimum Outside Air Damper Position Setpoint Schedule to Send Area 3
  - w. Minimum Outside Air Damper Position Setpoint Schedule to Send Area 4
  - x. Astroclock Lights Off After Sunrise /On Before Sunset Send Schedule Area 1
  - y. Astroclock Lights Off After Sunrise /On Before Sunset Send Schedule Area 2
  - z. Astroclock Lights Off After Sunrise /On Before Sunset Send Schedule Area 3
  - aa. Astroclock Lights Off After Sunrise /On Before Sunset Send Schedule Area 4
  - bb. Heating Systems Send Schedule Area 1
  - cc. Heating Systems Send Schedule Area 2
  - dd. Heating Systems Send Schedule Area 3
  - ee. Heating Systems Send Schedule Area 4
- .6 Locally Distributed Network Variables Distributed between Master controller and each Controller within each site: These Network Variables are centrally managed and distributed to each controller. A local copy of these variables are maintained and are adjustable when the site is set to local mode operation.
- a. Outside Air Temperature
  - b. Local Holiday Schedule
  - c. Fire Alarm Status
  - d. Ventilation Lockout Status
  - e. Heating Outside Air Temperature Enable/Disable
  - f. Cooling Outside Air Temperature Enable/Disable
  - g. Zone Temperature Night Setback Heating Temperature Setpoint
  - h. Zone Temperature Night Setback Cooling Temperature Setpoint
  - i. Zone Temperature Setpoint Adjust
  - j. Holiday Scheduling
  - k. Minimum Outside Air Enable Schedule
- .7 Additional calculated parameters used in the sequence of operations and shared across the site network:
- a. Minimum Zone Temperature per Controller
  - b. Maximum Zone Temperature per Controller
  - c. Minimum Zone Temperature per Site (data is aggregated across all the controllers and concentrated at the single master controller that triggers the low temperature alarm contacts)

- d. Maximum Zone Temperature per Site (data is aggregated across all the controllers and concentrated at the single master controller)

**END OF SECTION**

## **1. 26 05 00 COMMON WORKS**

### **1.1 General Requirements**

- .1 The Procurement and Contracting Requirements as outlined under Division 00, and the General Requirements as outlined under Division 01, and all addenda thereto shall apply to and govern all portions of the electrical work.
- .2 Reference Division 27 and Division 28 for additional requirements.
- .3 Points not specifically mentioned shall be in strict accordance with the Ontario Electrical Safety Code (OESC) and regulations of the Electrical Inspection Department from which the permit was obtained. The latest revisions and/or amendments to this Code, with applicable date restrictions, shall also govern work on this contract.
- .4 It is the intent of these specifications to supply and install all materials and equipment as herein specified, and/or shown on the drawings in such a manner as to leave each of the systems of the electrical trades complete and in satisfactory operating condition. Provide all products and methods specified or shown complete with incidentals necessary for a complete operating installation. The contract documents are not intended to enumerate each and every detail which may be necessary to furnish and install the complete system connected up ready for service operation. The bid shall include all such details, and all associated labour and materials, to provide a complete and working system. The omission of any details in the contract documents shall not be a warrant for the installation of poor workmanship or materials, or the omission of such details. The scope of the work to be performed by the Contractor shall be obtained by a careful examination of these specifications and all electrical drawings.
- .5 These specifications are to be considered as an integral part of the plans which accompany them, neither the plans nor the specifications shall be used alone. Any item or subject omitted from one but which is mentioned or reasonably implied in the other shall be considered as properly and sufficiently specified and must, therefore, be provided by the Contractor. Misinterpretation of either the plans or the specifications shall not relieve the Contractor of responsibility.
- .6 The Electrical Subcontractor shall be held responsible for the satisfactory completion of all work bearing upon their trade.
- .7 The Electrical Subcontractor must make note of any inaccuracies or inconsistencies in the drawings and/or specifications. Prior to bid close, any such items shall be disclosed, following the procedure outlined in the Invitation to Proponents.
- .8 Within this design, the term "provide" is defined as "supply and install".
- .9 Extra charges for premium time labour shall be included in the bid price as required to comply with the construction schedule and the restrictions on when work will be permitted in the existing building. Allow for after hours, weekend and holiday labour requirements.
- .10 Re-mobilization of any resources or sub-trades as required to maintain schedule or construction sequencing shall be included.

### 1.2 Questions

- .1 Questions pertaining to the work shall be submitted to the Consultant in writing in the form of a Request for Information (RFI).
- .2 Allow for up to two weeks for RFI response from the Consultant. Claims for delay within this period will not be accepted.

### 1.3 Codes, Permits and Submissions

- .1 All work shall comply with the OESC (current edition, including all bulletins and amendments) and all local and municipal codes and Government agencies having jurisdiction.
- .2 It is understood that the Subcontractor has examined and checked all drawings and specifications with the local authorities and the equipment and materials supplied by the Subcontractor shall have the approval of CSA, ULC, Factory Mutual (FM) and any other authority having jurisdiction.
- .3 The Electrical Subcontractor shall obtain and pay for all necessary permits and inspection fees as may be required by the public administrative authorities having jurisdiction. Any changes or alterations required by an authorized inspector shall be rectified by the Electrical Subcontractor without charge to the Owner.
- .4 Plans have not been submitted to the Electrical Safety Authority (ESA) Plans Approval Department. In accordance with the requirements of 2-010 of the OESC, plan submission is not required for this project.
- .5 All new electrical equipment must conform to the regulations of the Ontario Electrical Safety Code (OESC). Anything necessary to make the equipment comply with these requirements shall be provided without additional cost to the Owner.
- .6 Submit all required documentation to the authorities for their approval and comment before starting any work. Provide all additional drawings, details or information as may be required.
- .7 Inform the Consultant in writing if modifications to the work are requested by the authorities. Provide complete written description of the concerns raised.

### 1.4 Standards of Workmanship and Materials

- .1 All materials supplied by the Contractor shall be new and of the quality specified. All such materials shall be certified by CSA or other organization approved by the ESA. For any material not so certified, the Electrical Subcontractor shall obtain special approval of the local Inspection Authority and shall bear all inspection charges levied and any modification cost required.

### 1.5 Quality Assurance and Regulatory Agencies

- .1 All materials, installations supplied and performed by the Electrical Subcontractor shall be new and meet the standards of quality as specified herein:

- a. Canadian Standards Association - CSA.
- b. Ontario Regulation 163/24 (2024 Ontario Building Code) - OBC with amendments.
- c. Local Fire Codes.
- d. Ontario Ministry of Labour.
- e. Ministry of the Environment.
- f. Ontario Electrical Safety Code.
- g. Local Electrical Inspection Department.

#### 1.6 Contractor's Shop

- .1 Each Subcontractor shall provide their own office, workshop, tools and materials storage as required, and be responsible for any loss or damage thereto.

#### 1.7 Setting Out of the Work

- .1 The electrical trade shall be responsible for correcting all work completed contrary to the intent of the drawings and specifications and shall bear all costs for same. Where the intent of the documents is not clear the electrical trade shall obtain the clarification of the Engineer before proceeding with the work.
- .2 Where any equipment supplied by the electrical trade must be built-in with work of the other Subcontractors, the Electrical Subcontractor shall be responsible for the supplying of the equipment to be built-in or measurements to allow necessary openings to be left so as not to hold up the work.
- .3 In setting out of the work the electrical trade shall reference Architectural, Structural and Mechanical drawings. Electrical shall consult with the respective trades in setting out locations for conduit runs, lighting fixtures, panel assemblies, etc. so that conflicts are avoided and symmetrical even spacing is maintained. Being there first is not a permissible excuse.
- .4 Do not scale drawings for installation purposes. Obtain all dimensions from Architectural plans, manufacturers Shop Drawings and onsite inspections.
- .5 Before submitting bid, carefully examine the site of the proposed work so as to ascertain all existing conditions affecting the work. No extras will be allowed for work necessitated by conditions ordinarily evident on the site.
- .6 Installation of conduits, outlets and equipment in mechanical areas shall not proceed until the installation of mechanical equipment is far enough progressed to avoid conflicts. Position of electrical equipment and outlets shall be adjusted in these areas to coordinate with mechanical equipment.

#### 1.8 Preparation

- .1 Cutting and Patching
  - a. The Electrical Subcontractor shall be responsible for all cutting and patching of any building construction made necessary by the installation of the work except in such instances as may be otherwise assigned by the specifications or shown on the drawings. All cutting and patching shall be to the satisfaction of the Consultant.

- b. Finishing shall be by General trades.
- .2 In areas otherwise unaffected by the work of this contract, trades that are required to disturb existing finishes shall patch the existing surfaces and provide new finishes to the area of the wall or ceiling surface affected. Paint colour shall be selected to match existing. Repainting of entire walls or surfaces is not required unless a reasonable paint match cannot be obtained.
- .3 Existing ceiling tiles and grids shall be removed and replaced as required to permit the work. Ceiling tiles and grids that are damaged, or left with holes shall be replaced with new to match existing.
- .4 All devices required to be removed in walls being renovated shall have the hole patched to match existing. All devices required to be removed in existing walls not being renovated shall have suitable blank cover plates installed.
- .5 Existing concrete structure may contain concealed conduits. The Electrical Subcontractor shall retain the services of a qualified concrete imaging company to scan for existing buried services prior to cutting/coring/drilling.
- .6 The Electrical Subcontractor shall provide all sleeves, inserts, hangers, flashings, back boxes, tubs, junction boxes, etc. required for the completion of the work. Locations shall be coordinated with the respective subtrade into whose materials they are being installed.
- .7 Structural members shall not be cut without the consent of the Structural Engineer. For all necessary cutting, channelling, core drilling, sleeving etc., the Electrical Subcontractor shall provide their own forces and necessary equipment required to complete the electrical installation.
- .8 All floor mounted electrical equipment such as boards, transformers, etc. shall be mounted on 4" (100mm) high concrete pads supplied and installed by the Contractor. All concrete shall be 25MPa complete with a WWF152x152-MW18.7xMW18.7 welded wire mesh installed 2" (50mm) below the surface of the concrete. Provide smooth trowel finish for all concrete surfaces. Clean and roughen existing concrete surfaces under all new pads. The concrete pads shall extend past the edges of all equipment by a minimum of 3" (75mm).

#### 1.9 Continuity of Services

- .1 Service power and distribution system power interruptions shall be kept to an absolute minimum.
  - a. Power interruptions must be coordinated with the Owner and all other trades by the Electrical Subcontractor.
  - b. Written application for electrical interruptions must be received from the Contractor indicating the date, time and estimated duration of the interruption.
  - c. Application for approval of the power interruptions must be submitted to the Owner and Consultant at least two weeks prior to the requested shutdown date.
- .2 No Electrical work of any description will be permitted during normal hours in areas inside the building that are normally accessible to occupants. Work may be carried out during normal hours provided it does not extend into building areas accessible to occupants.

- .3 Provide all barricades as required.
- .4 All work shall be coordinated so that there is complete and continuous life safety protection throughout the entire facility (fire alarm and detection, emergency and exit lighting). System down times shall be kept to an absolute minimum.
- .5 Access control, intrusion detection, fire alarm and detection, and emergency lighting systems must be operational at all times when the contractor is not physically on site. Failure to keep these safety features operational may result in the contractor performing after-hours and weekend fire watch at their own cost.
- .6 At times when the fire alarm and detection system must be in a non-functional state, the following procedure shall be followed:
  - a. Contact the monitoring company to inform them of the shutdown.
  - b. Contact the local fire department to inform them of the shutdown.
  - c. Establish an alternate source of alarm, i.e., telephone, siren, etc.
  - d. Carefully monitor all high risk fire areas such as kitchens and mechanical rooms.
  - e. Ensure all building occupants are aware of the shutdown, the alternate source of alarm, and the time at which the system will be back on line.
- .7 All necessary system interruptions shall occur at a time suitable to the Owner and may be required to be at times that the building is not occupied or outside of regular business hours.
- .8 If overtime work or temporary wiring provisions are required to maintain services as required herein such work shall be included in the bid.

#### 1.10 Demolition

- .1 Existing lighting shall remain for construction purposes. Provide temporary support for existing fixtures to permit demolition. Ensure that there is adequate lighting for construction throughout the entire process.
- .2 The Electrical Subcontractor shall visit the site to examine the existing conditions and make necessary allowances in the bid for removal, rerouting, relocation, and reconnecting of equipment as may be necessary for the execution and completion of this project. Extra charges for premium time shall be included in the bid.
- .3 Wiring, conduits, etc., located in areas being altered or demolished, but feeding outlets or equipment required to remain in service shall be rerouted as required to maintain the continuity of these services, to the satisfaction of the Engineer.
- .4 In areas requiring installation of new duct risers for roof-mounted mechanical equipment, include for relocating conduits that may interfere with new openings. Confirm exact extent of work on site prior to close of bids.
- .5 Include for strapping existing conduits and cables that are not properly supported and are required to remain above ceilings. Determine exact extent of work on site.

- .6 The Electrical Subcontractor shall provide adequate protection to existing equipment throughout the project and particularly where wiring, piping, equipment, etc., have become exposed to mechanical injury or moisture.
- .7 Existing distribution equipment shall be permitted to be reused only as indicated on the drawings .
- .8 Existing equipment being reused shall be checked for proper operation. Reused equipment shall not have any sign of physical abuse or corrosion. Any knockouts removed in existing equipment being reused shall be plugged.
- .9 All wiring made redundant due to demolition/renovation work shall be disconnected and removed to the nearest distribution point upstream that is not affected by demolition/renovation work. All concealed conduit made redundant due to demolition/renovation work may remain provided it does not adversely affect any new installations, unless it is noted to be removed on the drawings. All exposed conduit in finished areas made redundant due to demolition/renovation work shall be removed and the surface patched.
- .10 Existing wiring devices shall not be permitted to be reused. Existing outlet boxes may be reused if in "as new" condition. Existing branch circuit wiring will only be permitted to be reused in existing non accessible walls/ceilings where the existing wiring is of adequate size, has acceptable bonding conductor and is in as new condition.
- .11 Where Asbestos Containing Material (ACM) will be disturbed in the execution of this contract, comply with the regulation respecting asbestos on construction projects and in buildings and repair operations made under the Occupational Health and Safety Act, Ontario Regulation 654/85 and local requirements pertaining to asbestos. Refer to the Designated Substances Report. Employ only licensed asbestos removal trades to execute abatement of all asbestos.
- .12 The abatement of all asbestos containing material (ACM) within a 600mm radius of any electrical work shall be completed by the general contractor/abatement contractor. Electrical subcontractor shall coordinate all work with the general contractor/abatement contractor.
- .13 All existing panel directories, zone legends and distribution equipment identification shall be reworked to reflect any changes made by the work. All existing wiring device tags shall be replaced to reflect any changes made to the upstream distribution designations.
- .14 The Electrical Subcontractor shall be responsible to ensure that all existing communications and security systems are undamaged during the course of demolition and renovations.

#### 1.11 Disposal

- .1 The Electrical Subcontractor will be responsible for the complete removal of all electrical equipment and systems to permit alterations, all as shown and noted on the plans. This includes removal of all such equipment from the site.
- .2 All miscellaneous equipment being removed shall become the property of the Owner unless shown otherwise. If the Owner has no use for it, all material shall be responsibly disposed of,

in a timely manner, by the subcontractor in accordance with all applicable federal, provincial and municipal acts, bylaws and regulations.

- .3 All appropriate measures to the health and safety of employees and Waterloo Regional District School Board (WRDSB) personnel shall be observed.

#### 1.12 Shop Drawings

- .1 The Electrical Subcontractor shall submit Shop Drawings to the Project Manager and/or Engineer for review. They shall show in detail the design, construction and performance of all apparatus.
- .2 Shop Drawings shall be submitted electronically in editable Portable Document Format (.PDF). Hard copy (paper) format Shop Drawings shall not be processed and shall be recycled.
- .3 Submissions shall be made in a timely manner after award of the contract. The first Application for Payment may not be approved unless all Shop Drawings have been received.
- .4 The Engineer's and/or Project Manager's review of Shop Drawings and manufacturer's specifications is general and is not intended to serve as the final check. It shall not relieve the Contractor from responsibility for errors.
- .5 Before submission, the subcontractor shall check all Shop Drawings for accuracy of details, dimensions etc. Do not proceed with work on any item for which shop drawing review has not been performed by the Engineer.
- .6 Any deviations whatsoever from the materials and methods specified herein must be clearly outlined in writing and such an outline must accompany the Shop Drawings of the proposed deviation.
- .7 Any deviations whatsoever from items specified to that proposed on the Shop Drawings shall be clearly identified and listed in red on the front of the Shop Drawings.
- .8 All Shop Drawings shall be arranged so that all drawings of a particular system are in one file and are in logical order. Shop Drawings that are submitted individually or are not arranged by system shall be rejected. For example, the lighting system Shop Drawings shall be submitted to include each fixture in order as listed in the "LIGHTING FIXTURE SCHEDULE".
- .9 Any materials that require a colour selection shall have colour samples submitted for Owner/Architect review and acceptance. Arbitrary colour selection by the supplier is not acceptable. Any item for which a formal colour selection is not submitted and approved will not be permitted on site.
- .10 Allow maximum two (2) weeks for the Consultant review.
- .11 Shop Drawings outlining all components shall be submitted for the following:
  - a. Power distribution equipment including the following:
    - i. Breakers
    - ii. Panels.

- iii. Transformers.
- b. Lighting fixtures.
- c. Emergency lighting and exit signage.
- d. Lighting controls.
- e. Wiring devices (refer to Section below).
- f. Fire stopping.
- g. Hand Dryers.
- h. Pathways for communications and security systems.
- i. Clock.
- j. Fire alarm and detection.
- k. Integrated Testing Plan for fire protection and life safety systems.

#### 1.13 Use of Electronic Files

- .1 A waiver must be executed prior to release of any electronic files or digital data.
- .2 Electronic documentation for release may consist of drawing files in formats such as Portable Document Format (.PDF), AutoCAD (.DWG), or Revit (.RVT). Specifications, details, schedules, legends, etc. shall generally not be released.
- .3 Electronic documents shall be used only for the specific use outlined in the waiver. The recipient may use this data for this purpose, at their own risk.
- .4 Copyright and ownership of the data are not transferred to the recipient, nor to any other party. The design professional and/or owner retain all rights to the data.
- .5 Data delivered in electronic form may vary from that contained on copies of previous issues. This information is not guaranteed to be accurate. The method of data transfer cannot be guaranteed to be error free, or compatible with the recipient's hardware, software, or systems. Contractors and subcontractors are not relieved of their normal responsibilities to independently check, coordinate, and verify information and dimensions, and to familiarize themselves thoroughly with the project. The documents may have been changed or amended by addendums, bulletins, supplemental instructions, shop drawings, other documents, meetings, and understandings not represented on these files.
- .6 The electronic files shall not be used as a substitute for the contract documents. The author offers no warranty or guarantee, express, implied, or statutory as to the accuracy, reliability, suitability, completeness or fitness of this data for a particular purpose. The company in receipt of these files agrees to the fullest extent permitted by law, to defend, indemnify, and hold the author, their directors, officers, partners, employees, harmless from all losses, claims, liabilities, injuries, damages, and expenses, including attorneys' fees and costs of defense, arising out of the use, misuse, misapplication, or misinterpretation of this data.
- .7 The recipient will not distribute the data to any other firm or individual. Redistribution and copying of the digital data without written authorization from the author writing is prohibited.

#### 1.14 As-Built Drawings

- .1 The Contractor shall provide redline drawings that accurately record the location of all outlets and conduit runs etc., and all circuiting of devices, as installed on site.

- .2 The Consultant shall provide, at no cost, AutoCAD drawing files incorporating Changes and Instructions.
- .3 Prior to Substantial Performance of the work, the Contractor shall edit the electronic files to provide AutoCAD as-built drawings that incorporate all redline information. Associated costs shall be carried in the bid.

#### 1.15 Closeout Documentation

- .1 Upon Ready-for-Takeover, the Contractor shall submit a Maintenance and Instruction Manual as well as as-built drawings. Submit one paper hard copy in a three-ring binder, and one .PDF electronic copy on a suitably sized USB thumb drive. Each manual shall contain one copy of the following:
  - a. Shop Drawings (revised as reviewed by the Engineer).
  - b. Spare Parts Transmittal to the Owner.  
Digital photos indicating each labeled distribution panel with the cover off.
  - c. Megger Test Results.
  - d. Updated panel directories.
  - e. ESA Final Inspection Certificate.
  - f. Emergency Lighting and Exit Sign Test Report.
  - g. Lighting Control System Operating Instructions.
  - h. Fire Alarm System Verification Report(s).
  - i. Integrated Testing Report for fire protection and life safety systems.
  - j. Written Guarantee (Warranty).
  - k. Sign back of the latest Site Review Report to confirm completion.
- .2 Include for updating the Owner's Continuous Safety Services (CSS) ESA log book for all electrical work.

#### 1.16 Testing

- .1 At the date when Ready-for-Takeover has been attained, the Electrical Subcontractor shall provide acceptance tests to demonstrate that the equipment and systems actually meet the specified requirements. Tests may be conducted as soon as conditions permit. These shall include but shall not be limited to the following:
  - a. Lighting system control.
  - b. Emergency lighting function.
  - c. 3000VDC Megger tests on all XLPE insulated feeders, 60A and larger, 15s duration.
  - d. 1000VDC Megger tests on all PVC insulated feeders, 60A and larger, 15s duration.
  - e. Fire alarm and detection system function.
  - f. Voltage drop measurements.
  - g. Current balancing in all panels (adjust to be within 15%).
  - h. Transformer tap adjustments (adjust to within 2.5%).
  - i. Proper phase rotation.
  - j. Existing communications and security equipment and associated cabling.

- .2 Concurrently, written approvals or acceptances by local authorities shall be presented. In testing, vary loads to illustrate start-up, sequence, normal shut down and simulate emergency conditions. Final tests may be conducted in the presence of the Consultant.

#### 1.17 Training and Demonstrations

- .1 The Electrical Subcontractor shall arrange for onsite instruction and training to the Owner on the operation and maintenance of the following:
  - a. Lighting control system.
  - b. NFPA hood interlocks.
- .2 Provide for a minimum of two training sessions of four hours each with the Owner.

#### 1.18 Commissioning

- .1 The Electrical Subcontractor shall retain the services of an Integrated Testing Coordinator (ITC) for all systems that are designed to operate together to achieve an overall fire protection and life safety objective, in accordance with OBC 3.2.10.
- .2 Refer to Division 01 for additional commissioning details.

#### 1.19 Warranty

- .1 The electrical trade shall furnish a written guarantee stating that all work executed under this contract will be free from defects of workmanship and materials for a period of two (2) years from the date when Ready-for-Takeover has been attained. The period shall in no way supplement any other warranty of a longer period.
- .2 The Electrical Subcontractor will at their own expense, repair and replace all such defective work and other work damaged thereby which fails or becomes defective during the term of the warranty provided that such failure is not caused by improper use.
- .3 Refer to the Division 01 specifications for additional warranty details.
- .4 Include for completion of the WRDSB Project Warranty Card prior to Substantial Performance of the work.

#### 1.20 Electrical Equipment Approved Equals

- .1 Unless specifically stated otherwise, this project has been designed based on the first named manufacturer of each section in the "ALTERNATE MANUFACTURERS LIST" or that specifically listed in the schedules. If the Electrical Subcontractor chooses to use a manufacturer other than the first named manufacturer, it will be their responsibility to ensure that the alternate is equal in all respects to that of the first named manufacturer. The Engineer reserves the right to approve or reject any alternate based upon an evaluation of the equipment proposed. If only one manufacturer is listed then only that manufacturer shall be acceptable.

#### 1.21 Alternate Manufacturers List

- .1 Distribution Equipment
  - a. Eaton
  - b. Schneider Electric (Square D)
  - c. Siemens
  
- .2 Motor Starters, MCC's, Contactors
  - a. Eaton or Klockner Moeller
  - b. Schneider Electric (Square D) or Telemecanique
  - c. Siemens
  - d. Allen Bradley
  
- .3 Dry Type Transformers
  - a. Hammond
  - b. Atlas
  - c. Rex
  - d. Marcus
  - e. E-Factor
  - f. Delta
  
- .4 Switches, Receptacles and Wiring Devices
  - a. Hubbell
  - b. Eaton Wiring Devices
  - c. Pass and Seymour
  - d. Leviton
  
- .5 Lighting Controls
  - a. Acuity
  - b. Lutron
  - c. Hubbell
  - d. Steinel Lighting Controls
  - e. Cooper Lighting Solutions
  - f. Wattstopper
  
- .6 Support Channels, Cable Tray and Hangers
  - a. Cooper (B-Line)
  - b. Hubbell
  - c. Unistrut
  - d. Canstrut
  - e. Caddy (Erico)
  - f. T.J. Cope (Tyco)
  
- .7 Surface Raceway
  - a. Hubbell

- b. Wiremold
  - c. Panduit
- .8 Fire Stopping
- a. 3M
  - b. Hilti
  - c. AD Firebarrier
  - d. STI
- .9 Lighting Fixtures (Luminaires) - Interior
- a. Refer to "LIGHTING FIXTURE SCHEDULE"
  - b. Lithonia
  - c. Hubbell
  - d. Signify (Cooper/Philips)
- .10 Lighting Fixtures (Luminaires) - Exterior
- a. Refer to "LIGHTING FIXTURE SCHEDULE"
  - b. Lithonia
  - c. Hubbell
  - d. Signify (Cooper/Philips)
  - e. RAB Design
  - f. Lumecon
- .11 Emergency Lighting and Exit Signage
- a. Refer to "LIGHTING FIXTURE SCHEDULE"
  - b. Stanpro
  - c. BeLuce
  - d. AimLite
  - e. Emergi-Lite/Ready-Lite/Lumacell (Thomas & Betts)
  - f. Dual-Lite (Hubbell)
- .12 Assistive Listening
- a. Refer to Division 27.
- .13 Audio/Visual
- a. Refer to Division 27.
- .14 Clocks
- a. American Time
- .15 Fire Alarm and Detection
- a. Troy Life & Fire Safety Ltd.

- .16 Access Controls
  - a. Refer to Division 28.

#### 1.22 Access Doors

- .1 Supply access doors to the Contractor for installation for all concealed electrical equipment requiring accessibility for service and maintenance such as junction boxes, pull boxes, relay enclosures, controls, etc. All doors shall be a minimum size of 8" x 8" (200mm x 200mm) and a minimum size of 24" x 18" (600mm x 450mm) where human access is required unless otherwise noted and shall be complete with positive locking self-opening screwdriver lock. The exact size of all access doors shall be as recommended by the manufacturer to suit the application.
- .2 Doors shall be manufactured by Acudor and shall be of the following types (choose applicable type):
  - a. Drywall and Block - UF-5000, prime coated steel, flush style door with wall frame and screwdriver operated cam lock.
  - b. Ceramic Tile - UF-5000-SS,#4 satin polish stainless steel door with wall frame and screwdriver operated cam lock.
  - c. Plaster Finish - PS-5030, prime coated steel, flush style door with wall frame and screwdriver operated cam lock.
  - d. Fire Rated Partitions - FB-5060, prime coated steel fire rated door, ULC-2.0 hour "B" label with self-closing key operated locking door.
  - e. Fire Rated Ceilings - FW-5050, prime coated steel fire rated door, ULC-1.5 hour "B" label with self-closing key operated locking door.

#### 1.23 Equipment Supplied By Others

- .1 The Electrical Subcontractor is to supply all wiring, disconnect switches, motor starters, etc., for all Owner-supplied and mechanical equipment, unless noted otherwise. Detailed equipment information is given on drawings "WIRING FOR EQUIPMENT SCHEDULE".
- .2 The Electrical Subcontractor shall ensure that all equipment is certified by an agency recognized by ESA (CSA, Entela, etc) prior to energization. If such certification is not present, this subcontractor shall arrange for special inspection by ESA, and all costs for this extra work shall be paid by the Owner.
- .3 Coordinate exact electrical requirements for all equipment with Shop Drawings and actual nameplate data. Revise electrical requirements to suit.

#### 1.24 Allowances

- .1 Refer to Section 01 21 00 for allowance details.
- .2 Any ESA inspection charges shall be included in the project cost and shall be paid for by the Contractor.

#### 1.25 Substantial Performance Certificate

- .1 Before the Contractor can make application for a Certificate of Substantial Performance of the work, the Electrical Subcontractor will be required to provide the following as detailed within this section:
  - a. Maintenance and Instruction Manuals.
  - b. As-Built drawings.
  - c. Testing.
  - d. Training and Demonstrations.
  - e. Commissioning.

#### 1.26 Contractor's Liability Insurance

- .1 The successful bidder is to maintain adequate insurance as specified by the Owner's Standard Form of Contract. This insurance is to firmly protect both himself and the Owner from public liability claims and property damage, and all claims under the Workman's Compensation Act. Evidence of insurance coverage shall be filed and approved.

#### 1.27 Payment Certification

- .1 Submit monthly draws to the consultant for review and certification. Draws shall provide a complete breakdown of project in a manner acceptable to the consultant. Submit sample Application for Payment and a proper invoice template to the consultant four weeks prior to first draw for review.

#### 1.28 Extras and Credits

- .1 Only extras and credits approved by the Electrical Engineer or their representative will be allowed and must be submitted for approval before such work commences. They shall be priced individually with a complete breakdown clearly indicating labour costs, material cost, mark-up and taxes. Labour rates and material costs for extras and credits shall be identical. Material shall be valued at current trade prices incorporating all discounts. Only the net difference between an extra and a credit will subject to overhead and profit mark-up.

#### 1.29 Spare Parts

- .1 Provide the following components as spare parts:
  - a. Four (4) type "EBA" emergency lighting fixtures.
  - b. Four (4) type "EBB" emergency lighting fixtures.
  - c. Four (4) type "EB" emergency lighting fixtures.
  - d. Six (6) type "EXA" exit signs.
  - e. Six (6) type "EXB" exit signs.
  - f. Three (3) addressable smoke detectors.
  - g. Three (3) addressable heat detectors.
  - h. Two (2) Fire alarm horns.
  - i. Two (2) Fire Alarm horn/strobes.
  - j. Two (2) fire alarm input modules, complete with end-of-line resistors.

- .2 Allow for installation of all spare parts in base contract. If not required to be installed, turn over to Owner upon project completion.
  
- .3 Obtain sign-off by the Owner representative to confirm receipt of all spare parts, accessories and tools. Sign-off shall consist of printed name and signature.

## **2. 26 05 14 EQUIPMENT IDENTIFICATION**

### 2.1 General

- .1 Provide all nameplates for equipment such as panels, starters, disconnect switches, transformers, contactors, etc.
- .2 Nameplates shall indicate Year, Equipment Name, Source and Electrical characteristics (ampacity, voltage, phases, number of conductors), i.e., 2026, Panel "C" fed from Panel "SE", 150A, 120/208V, 3-phase, 4-wire.
- .3 All equipment/circuits/devices that reference room names or numbers shall be modified as required to reflect the finalized Owner designated room names/numbers. Do not duplicate the room numbers indicated on the drawings.
- .4 Nameplates shall be a stock white lamacoid, with black lettering and with beveled edges. Letters shall have a minimum 0.06", (1.5mm) stroke.
- .5 Nameplate engraving shall be as follows:
  - a. Electrical equipment name: 0.5", (13mm) high.
  - b. Electrical equipment characteristics: 0.25", (6mm) high.
- .6 Equipment nameplates shall be mechanically fastened with tamperproof screws. Equipment nameplates that are fastened with adhesives shall not be acceptable.
- .7 Provide adhesive labeling for wiring devices such as receptacles, switches, speed controllers, etc. Labels shall indicate the circuit(s) that serve the device, i.e., "SC1".
- .8 Provide all warning signs and labels as required by the ESA.
- .9 Provide typed directory cards in all new and revised distribution panels. Hand written directory cards are not acceptable.
- .10 Provide preprinted slip on conductor identification tags for all conductors as they enter electrical enclosures, equipment, and outlet boxes (switches, receptacles, light fixtures, etc). Tags shall be Thomas and Betts "EZCode" SMC series or approved alternate. Cloth or vinyl markers are not acceptable.
- .11 All empty or spare conduit shall be identified with black indelible marker.
- .12 All junction boxes shall be identified with black indelible marker showing the systems with which they are associated, i.e., lighting, receptacles, fire alarm, etc. Where boxes are exposed, identification shall be on the inside of the cover.
- .13 Repaint or refinish all damaged factory applied finishes.

---

### **3. 26 05 21 RACEWAYS, WIRE AND CABLE**

#### **3.1 General**

- .1 All wiring in noncombustible areas, unless otherwise noted, to be CSA approved soft copper, type T90/TWN75 in conduit, unless otherwise required by the Electrical Code for specific areas or environmental conditions.
- .2 Maximum voltage drop at most remote outlet not to exceed 3% in accordance with OESC #8-102. The minimum wire size shall be #12 AWG.
- .3 All low voltage (0-10V) dimming cabling shall be CSA approved soft copper, type T90 installed in raceway or metal armour. The minimum wire size shall be #16 AWG. Wiring colours to be violet and grey. Insulation rating shall be equivalent to the phase conductors serving the lighting fixtures. A cable that combines power conductors with control conductors under one armour may be used.
- .4 All neutral feeder conductors shall be a minimum of two gauges larger than the respective phase conductor, i.e., 3-#3/0 phase conductors shall include 1-#250 neutral.
- .5 Where feeders/branch wiring/conduit are installed below floor slab, they shall be installed in the granular material below the slab with a minimum of 4" (100mm) cover. Do not install within concrete.
- .6 There shall be one neutral conductor for each phase conductor in a branch circuit. Sharing of neutrals shall not be permitted.
- .7 Armored cable (BX) may be used in metal stud partition walls, in concrete block walls, and for final drops to fixtures in accessible ceiling spaces. Cable length shall not exceed 3.1m (120") horizontally in accessible ceilings. BX cable shall under no circumstances be run exposed.
- .8 EMT shall be used in dry concrete slabs and for interior exposed surface applications (where permitted). Surface mounted EMT may be permitted on existing finished walls only in areas where there is existing surface mounted EMT within 24" (600mm).
- .9 Rigid PVC (IPEX Scepter or approved alternate) raceways shall be used in or below concrete slabs, for direct burial, or exposed exterior surface applications. Conduit shall be FT4 rated.
- .10 All conduit and wiring is to be concealed in all finished areas unless otherwise approved. EMT conduit shall be permitted above and below surface mounted panels.
- .11 In finished areas with exposed ceilings, conduit and wiring shall be run concealed if possible. If not possible, conduits shall be EMT, surface mounted or suspended to suit the application.
- .12 Exposed or concealed conduits above ceilings shall be run in straight lines parallel to building structure. Diagonal runs will not be permitted.
- .13 Provide 9mm (3/8") polypropylene pull rope and pull tape in all empty conduits 53mm (2") and larger.

- .14 Provide nylon pull tape in all empty conduits smaller than 53mm (2").
- .15 Securely fasten pull rope/tape in empty conduits/raceways at each end.
- .16 Pull tape shall be Neptco WP900P, 0.5" (13mm) wide, 900lb (409kg) pull strength, lubricated, with sequential metric distance markings.
- .17 Conduits and cables shall not enter an exit stair shaft, unless they serve devices/fixtures within the exit stair, i.e., route all conduits and cables around the stair to maintain the integrity of the exit.
- .18 Install flexible conduit section in all locations on either side of an expansion joint where rigid conduit is fastened to structure.
- .19 All wiring serving rotating or vibrating equipment shall be stranded and shall be in a flexible raceway. Raceway length shall not exceed 1.5m (60").
- .20 Connections to equipment shall be flexible and of sufficient length to permit the equipment to be moved for servicing or housekeeping. Connections to kitchen equipment shall have PVC jacket.
- .21 Coordinate with HVAC trades to run feeders to rooftop equipment through the curb or alongside refrigerant lines. Separate roof penetrations/cones for feeders shall not be permitted.
- .22 Where separate roof penetrations are required, provide roof sleeves complete with flashing and rain shields. Recommended product is PortalsPlus Alumi-Flash.
- .23 Standard trade conduit connectors and fittings are acceptable unless noted on the drawings or specification to be a specific manufacturer trade name, catalogue no. or series.
- .24 In general, all outlet boxes shall be metal. The use of nonmetallic boxes shall not be permitted.
- .25 Outlet boxes located in areas normally accessible to building occupants shall have no exposed knockouts. Support all boxes independently of connecting conduits.
- .26 In areas where it is not possible to run conduits concealed in existing structures, surface mounted raceways shall be permitted. The Electrical Subcontractor shall verify the proposed locations of all surface mounted conduits with the Engineer prior to installation.
- .27 Where permitted, all surface mounted raceways shall be "Wiremold" series 2000, 500, or 700, as required to match the quantity and size of conductors. Surface mounted raceways shall be complete with all "Wiremold" fittings and accessories (couplings, bushings, clips, straps, elbows, outlet boxes etc.) to form a complete installation.
- .28 All exposed surface mounted raceways shall be painted by the Electrical Subcontractor to match the colour of the surface upon which it is installed if the surface is not specified to be painted by general trades.

- .29 All wiring situated in a return air plenum shall be totally enclosed in a non-combustible raceways or shall be FT6-rated (also known as Communications Media Plenum, or CMP).
- .30 All conduits and raceway systems shall be provided complete with plastic bushings on both ends.
- .31 The following special requirements are applicable to all areas identified as “wet” or “corrosive” on the drawings:
  - a. Wiring methods shall be as per Section 22 of the Ontario Electrical Safety Code.
  - b. Conductors shall be suitable for use in wet locations i.e., types TW, RW
  - c. Conductors shall be in rigid PVC.
  - d. Teck90 cable shall be permitted strapped to walls and on cable trays. TECK90 Cable shall be to CSA C22.2 No. 131 complete with the following:
    - i. RW90 XLPE conductor insulation.
    - ii. copper bonding conductor.
    - iii. PVC inner jacket.
    - iv. Interlocked aluminum armour.
    - v. PVC outer jacket , FT4 rated.
  - e. All fasteners, support channels etc, shall be PVC or stainless steel.
  - f. EMT and rigid aluminum raceways shall not be permitted.
  - g. All conduits, wiring and raceways shall be run concealed within the wall, ceiling, or floor structure wherever practicable.
  - h. Surface mounted wiring methods shall be permitted provided the conduits/raceways/cable assemblies are set off the face of the structure by minimum 1.0" (25mm) using stainless steel or other approved fastening devices. Strapping conduits/raceways/cable assemblies directly to the surface shall not be permitted.
  - i. Where cable assemblies (TECK 90) are surface mounted on a wall/surface, the cable shall be provided with adequate support to maintain a straight and true appearance.
  - j. Wet or corrosive areas shall include the entire floor area up to ceiling/roof structure. Areas above ceilings shall not be considered wet or corrosive unless specifically noted otherwise.

### 3.2 Fire stopping

- .1 Provide fire stop sealant / devices of a type to suit piping, building construction, opening size, etc. Supply and install according to manufacturers detailed installation instructions.
- .2 Indicate the fire stopping systems to be used at all conduit and wiring penetrations of fire rated building construction. Include certified drawings prepared by the fire stop manufacturer which are applicable to the application. These drawings shall indicate all certifications, wall / floor construction details, pipe size / material details, SP numbers, F and T ratings, etc. and they shall be keyed to floor plan blue prints which indicate the location of each fire stopping application.
- .3 Communications sleeves through rated penetrations shall be fire stopped by the Communications Subcontractor after cabling installations.
- .4 Combustible outlet boxes shall not be permitted.

- .5 Outlet boxes located on opposite sides of a vertical fire separations shall not be closer than 600mm (24") horizontally or shall be fire blocked to maintain the integrity of the separation. Fire block shall be 13mm gypsum board or 0.38mm sheet steel. Arrange and pay for fire block materials.
- .6 Firestop behind panels, enclosures, and outlet boxes greater than 160cm<sup>2</sup> (24.8 in<sup>2</sup> or four gang) recessed in fire rated separations using 3M Interam Endothermic Mat E-5A-4.
- .7 Firestop behind all enclosures and outlet boxes recessed in opposite sides of a required vertical fire separation and closer than 600mm (24") apart using Hilti CP617 or CFS-PA Firestop Putty Pads. Alternatively, fire block materials may be used subject to OBC 3.1.11.7 (2).
- .8 Coordinate with General Trades to be consistent with the fire stopping manufacturer throughout the project.
- .9 All sleeves/conduits installed to permit the passage of communications cabling through a fire separation shall be caulked with approved fire stopping material after the installation of all required cabling is completed to prevent the spread of smoke. Fire stopping material shall be applied by the Electrical Subcontractor regardless if communications cabling is provided by others. Verify with consultant prior to application.

### 3.3 Computer Raceway System - PVC

- .1 The computer raceways shall be Hubbell PB3BCx and shall possess the following features:
  - a. PVC construction, UL listed and CSA approved.
  - b. Office colour, paintable.
  - c. Two piece construction, U channel base with snap on cover.
  - d. Three internal barriered compartments with removable barrier. Middle compartment reserved for communications cabling.
  - e. Provide covers, end caps, elbows, device cover plates, connectors, tees and hardware as necessary for a complete raceway system.
  - f. Provide a PB3FCIB2G full capacity box for each station.
  - g. Power outlets shall feature one duplex receptacle in a IFP126OW face plate.
  - h. Communications outlets shall feature an ISF2OW outlet frame in a IFP126OW face plate. Provide blanks for unused ports.
- .2 Situate device mounting plates centered on workstations in the configuration indicated on the drawings.
- .3 Mount raceways to desks, benches, and walls in an approved manner and as indicated on the drawings with lengths to suit.
- .4 Provide one 1.0" (27mm) communications conduit for each 144" (3.6m) of linear raceway. Alternate arrangements are acceptable, provided an equal capacity is installed.

#### **4. 26 27 26 WIRING DEVICES**

##### 4.1 General

- .1 Provide all wiring devices and their associated fittings as indicated in the "Wiring Device Schedule" in this specification or as specifically noted on the drawings.
- .2 Wiring devices shall be black unless noted otherwise. Verify colour with Owner prior to ordering and adjust if required.
- .3 Wiring devices for general purpose shall be of heavy-duty specification grade.
- .4 Devices shall be manufactured and tested in accordance with CSA and EEMAC standards. Attachment plugs and receptacles to conform to CSA configurations.

##### 4.2 Wiring Device Schedule

- .1 Hubbell or Acuity serves as the basis for this specification. If the Contractor chooses to use an Approved Alternate manufacturer, as listed above, it will be their responsibility to ensure that the alternate is equal in all respects to that named herein. The Engineer reserves the right to approve or reject any alternate based upon an evaluation of the equipment/device proposed.
- .2 120V Switches
  - a. Decorator Style - 20A
    - i. DS120, DS320, DS420
  - b. Key Switches - 20A
    - i. HBL1221, HBL1223, HBL1224
    - ii. Provide one HBL1209 key with each lock switch
- .3 120V Receptacles
  - a. Ground Fault Circuit Interrupter (Weather and Tamper Resistant) - 15A
    - i. GFTWRST15
  - b. Ground Fault Circuit Interrupter (Weather and Tamper Resistant) - 20A
    - i. GFTWRST20
  - c. Decorator Style - 15A
    - i. HBL2152
  - d. Decorator Style - 20A (CSA 5-20R)
    - i. HBL2162
  - e. Decorator Style, Tamper Resistant - 15A
    - i. DR15xTR
  - f. Decorator Style, Tamper Resistant - 20A
    - i. DR20xTR
- .4 Hand Dryers
  - a. Comac One Series, 120V (Universal), 1450W (20A). Surface mounted, fixed nozzle, brushed stainless steel finish, automatic activation, low or adjustable DB. SteriTouch®

antimicrobial technology. Vandal proof, tamper-proof screws. Brushless external rotor motor. 1380w resistance coil.

- .5 Clocks
  - a. Typical 300mm clock shall be American Time Model No. E56BADD304BP.
  - b. All shall feature round, high impact plastic case with shatter-resistant safety crystal and bold black numerals and minutes markers on a non-yellowing white dial. Provide four AA alkaline batteries for each clock.
  - c. Include for custom logo.
- .6 Control Relays (BAS system, HVAC system)
  - a. Relays shall be Functional Devices Inc, type RIB, SPDT, contacts rating to suit connected load (minimum 10A at 120V), Coil voltage: 10-30VAC/DC or 120VAC, LED on indicator, open/closed/auto manual over ride switch. Relays shall have adequate number of poles to suit the loads being controlled.
- .7 Occupancy Sensors for Switching Environments
  - a. Refer to Lighting Control Schedule.
  - b. Provide guard model WGx to suit sensor where indicated.
  - c. The sensors shall operate at 24VDC, supplied by the PP20 power supply/relay pack. Locate PP20 units on as-built drawings. Up to fourteen sensors per PP20 unit.
  - d. Power supply/relay pack input voltage 120V or 347V to suit application. Relay contact rating 20A per pole at supply voltage.
  - e. Sensors may be wired in parallel to allow coverage of larger areas.
  - f. Extended range 360 degree.
  - g. White colour.
  - h. Set to minimum 20 minute operation.
  - i. Provide quantity of relay packs and slave packs to suit required load and switching arrangement indicated on the plans.
  - j. Sensors shall be located and adjusted per manufacturer's instructions to provide detection within the defined area.
- .8 Wall Switch Occupancy/Vacancy Sensors
  - a. Refer to Lighting Control Schedule.
  - b. The sensor shall operate at 120V to suit application. No control unit required.
  - c. Rated 800W at 120V.
  - d. Single gang box.
  - e. 180 degree coverage.
  - f. Effective range for small hand movements: 6m (20").
  - g. Sensors may be wired in parallel to allow coverage of larger areas.
  - h. Sensors shall be wall mounted, located and adjusted per manufacturer's instructions to provide detection within the defined area.
  - i. Coordinate desired time delay with the Owner. Set to minimum 20 minute operation.
  - j. Colour to match wiring devices.
  - k. Occupancy sensors shall be field programmed for auto ON, auto OFF.

- l. Vacancy sensors shall be field programmed for manual ON, auto OFF.
- .9 Cabled Lighting Controls for Dimming Environments (0-10V)
- a. Refer to Lighting Control Schedule.
  - b. Provide mounting kits and guards where indicated.
  - c. Provide non-booted CAT5e connections.
  - d. Provide quantity of power/relay packs as required.
  - e. Utility power/relay pack nPP16D EFP.
  - f. All luminaires shall come on automatically via occupancy sensor(s) to 50% illumination. Manual control of light levels by the dimmer after detection of occupancy.
  - g. All luminaires to automatically dim to off 20 minutes after no occupancy is detected.
  - h. Sensors shall be located and adjusted per manufacturer's instructions to provide detection within the defined area.
  - i. Manufacturer shall commission and test the entire system. Provide verification report.
  - j. Colour to match wiring devices.
- .10 Cover plates
- a. Plates shall be specification grade type 304 brushed stainless steel.
  - b. Plates serving the ceiling mounted devices shall have a matching white nylon cover plate.
  - c. Surface Exterior While-In-Use Weatherproof Covers:
    - i. Die-cast metal construction, gasketed.
    - ii. Lockable open or closed.
    - iii. Hubbell (Taymac) MX3300.
    - iv. Use only for mechanical equipment.

#### 4.3 Execution

- .1 All wiring devices to be flush mounted in all finished areas.
- .2 All switches shall be rated 20A minimum.
- .3 Where GFCI devices are shown on the drawings, an actual GFCI device must be installed. Feed through type arrangements are not acceptable.
- .4 Receptacles connected to 20A branch circuits shall be CSA 5-20R configuration.
- .5 Install boxes so as to be accessible after building is complete, set to be flush with finished lines of building structure, where recessed, and lined and leveled where surface mounted.
- .6 Switch and receptacle mounting heights shall be coordinated with Architectural details and shall be adjusted, if required to the satisfaction of the Architect/Engineer at no additional cost to Owner.
- .7 Where outlets occur in exterior walls, the electrical trade shall ensure that there is insulation and a vapour barrier behind the outlet box to prevent condensation through the boxes.

- 
- .8 Receptacles for maintenance of HVAC and similar equipment shall be mounted on the exterior of the equipment.
  - .9 Outlet boxes on opposite sides of a vertical fire separation having a fire-resistance rating shall be separated by one of the following:
    - a. A horizontal distance of not less than 600 mm,
    - b. A suitable fire block material, or,
    - c. Firestop installed on each outlet box that has an FT rating not less than the fire-resistance rating of the fire separation.
  - .10 Install switches with handle in the "Up" position when the switch is in the "On" position.
  - .11 Outlets located in masonry, textured or otherwise uneven wall/surfaces shall be mounted such that the cover plate is flush with the wall/surface. Grind or modify the face of the material so that the cover plate fits flush. The cover plate shall have an opening no larger than 1/8" (3.0mm) from the surface. Caulking shall not be permitted as a method of filling gaps larger than 1/8" (3.0mm).
  - .12 Install switches and/or receptacles in ganged type outlet boxes, with matching wall plate when more than one switch or receptacle is required in one location.
  - .13 Remove plastic protective film on stainless steel plates only after painting and other work has been completed in that area.
  - .14 Do not use cover plates designed for flush outlet boxes on surface mounted boxes. Do not use outlet boxes designed for flush mounting in surface mount applications.
  - .15 Install decorator style devices in all areas.
  - .16 Locate BAS system relays in location to suit the mechanical trades. Locate HVAC system relays in HVAC equipment control cabinet.
  - .17 Locate HVAC system relays in accessible location where shown on the floor plans.
  - .18 Locate power connections to Mechanical Power Supplies (MPS) in accessible location where shown on the floor plans.
  - .19 All low voltage lighting controls shall be provided with an appropriately sized outlet box and a 0.5" (16mm) conduit to the accessible ceiling space. In cases where the ceilings are not accessible, extend conduit to within 6.0" (150mm) of the nearest associated power/relay pack.
  - .20 Locate power connections to Mechanical Power Supplies (MPS) & Plumbing Power Supplies (PPS) in accessible location where shown on the floor plans.

#### 4.4 Mounting Heights

- .1 Mounting heights to centre of box above finished floor (AFF), unless noted otherwise:
  - a. 18", (450mm): receptacles, communications outlets.

- 
- b. 30", (750mm): exterior receptacles above finished grade/roof.
  - c. 37", (940mm): base of barrier-free hand dryers. Confirm with Architectural details.
  - d. 41.5", (1050mm): light controls, timers, push buttons, variable speed controllers, wall-mounted telephones, key switches, public address call switches, power door push buttons, card readers.
    - i. Minimum height is 36" (900mm), maximum height is 43" (1100mm).
    - ii. Maintain minimum of 150mm horizontally from centre of all wall-mounted telephone outlets to the edge of any adjacent device (light control, thermostat, etc.).
    - iii. At locations with multiple power door operators, mount minimum 180mm horizontally apart on centre. Mount minimum 24" (600mm) and maximum 60" (1500mm) beyond door swing.
  - e. 44" (1118mm): base of Mens and Ladies hand dryers. Confirm with Architectural details.
  - f. 47", (1200mm): fire alarm manual stations, thermostats, end of line devices. Situate all fire alarm manual stations such that there is a minimum of 2" (50mm) of flat wall space on each side, and a minimum of 4" (100mm) of flat wall space above and below to allow for the installation of a future manual station protective guard.
  - g. 92", (2340mm): fire alarm visual and audible devices without silencing means. Install at least 6", (150mm) below ceiling to the top edge of the device. Visual devices shall not be lower than 78", (2000mm).
  - h. Devices above counter shall be 4" above millwork/back splash. Coordinate with Architectural details.
  - i. Fire alarm device modules and zone isolators shall be recessed in walls at 92" (2.34m) AFF or 6", (150mm) clear below ceiling, whichever is lowest. Clearly indicate location of modules on as-built drawings. Verify locations on site with Architect.
- .2 Controls adjacent to classroom doors shall be arranged to have thermostat closest to the door, followed by telephone, followed by lighting controls.
- .3 Where devices are to be mounted in block walls, outlet boxes shall be cut into the top or bottom of the nearest block course that is lower than the height specified.
- .4 Where a conflict of device mounting occurs, the Contractor shall contact the Engineer for clarification.

## **5. 26 24 01 DISTRIBUTION EQUIPMENT**

### 5.1 General

- .1 The Electrical subcontractor shall provide the distribution equipment required for the complete installation.
- .2 All distribution equipment shall be complete with drip shields suitable for use in a sprinklered environment.
- .3 Maintenance and operating instructions, parts lists, etc., shall be provided for any special function equipment.
- .4 Equipment shall be delivered to the site and shall be protected all around with a plastic covering. Additional onsite protection must be provided to keep the equipment protected from the elements and other trades. If there is any sign of rusting or corrosion or severe physical abuse on the equipment, the affected parts shall be replaced at no cost to the Owner.
- .5 All distribution equipment shall have tested and approved series ratings for fault currents and shall have identifying labels.
- .6 All distribution equipment shall have lugs with termination temperatures rated at 75°C minimum.

### 5.2 Panels

- .1 Provide surface or recessed panels of type, voltage, ampere capacity, number of poles, branch circuit, capacity, etc., as indicated.
- .2 All panel bus bars shall be tin plated aluminum unless specifically noted otherwise.
- .3 Panels shall have a hinged door with flush lock for access only to the breakers.
- .4 Balance all panels to give as near as possible equal current in all phases under full load conditions.
- .5 Provide 200% rated neutral lugs where outlined.
- .6 Provide a minimum of two 1.5", (41mm) spare conduits from each recessed panel to the nearest accessible ceiling space or utility space. Cap conduits and label as "spare."

### 5.3 Disconnect Switches

- .1 Disconnect switches shall have visible blades in the off position, quick make, quick break mechanism and shall have steel reinforced clips. Fuses shall be easily removable when the switch is in the off position. All switches shall have ample gutter space for top or bottom wiring.
- .2 Provision for padlocking in on-off switch position by one lock.

- .3 Switch mechanically interlocked door with front accessible defeat to prevent opening when handle in ON position.
- .4 Switches with pull out style contact devices shall not be permitted.

#### 5.4 Fuses and Breakers

- .1 Fuses shall be Class J dual element time delay as manufactured by Bussmann unless otherwise specified. Fuse rating shall be as noted or as required for proper protection. Fuses shall be rated for 200kAIC minimum.
- .2 Unless indicated otherwise, breakers shall be moulded case type, thermal-magnetic, ambient temperature compensated, of the frame size and with trip settings as indicated on the drawings. Breakers mounted in panels shall be bolt-on type.
- .3 Unless otherwise noted all breakers shall be rated minimum 10kA symmetrical interrupting capacity at 208V and 14kA at 600V.
- .4 Breakers serving transformers shall be of a type to withstand the inrush current. Manufacturer shall provide time-current curves for all such breakers demonstrating the ability to withstand transformer inrush currents for the specific transformer being supplied for the project.
- .5 All breakers indicated as "spare" shall be installed in the "OFF" position.
- .6 Breaker supplier shall allow for up to 10% of breakers to be returned and traded for equal breakers of two standard ampacity sizes higher or lower than that originally provided at no additional cost to the project.
- .7 The manufacturer shall arrange breakers in panels in the order indicated on the schedules. Rearrangement of breakers on site is not recommended.

#### 5.5 Contactors

- .1 Power contactors shall be of the voltage, ampacity and number of poles as indicated on the drawings. Contacts shall have mixed load ratings (lighting and motor) and be electrically held.

#### 5.6 Transformers

- .1 Three phase transformers 45kVA and larger shall be Class 220 insulation system rating, 150°C temp rise, less than 4.5% regulation at unity power factor, min 4.0% impedance, copper wound, not T wound. They shall be of the voltage and size as shown on the drawings.
- .2 Transformers located in sprinklered areas or on the exterior of the building shall be rated NEMA 3R.
- .3 All transformers shall be isolation type.
- .4 Dry type transformers shall comply NRCAN 2019 for energy efficiency.

- .5 Transformers shall have internal vibration absorbing pads and optional external moulded neoprene and steel vibration isolators.
- .6 Neutral generated by transformers shall be tied to building ground with ground conductor sized to code requirements.
- .7 Transformers shall have four (4) 2.5% full capacity taps, two (2) FCAN and two (2) FCBN.
- .8 Connections on HV and LV sides shall be flexible conduit or equivalent.
- .9 Transformers shall be mounted so that there is a minimum of 6", (150mm) clear space between unit and any adjacent noncombustible surface.
- .10 Provide minimum 1m (40") clearance on "front" side of transformer where terminations are made.
- .11 Sound pressure noise levels shall comply with CSA C9: 10-50kVA: 45dBA at 1.0m, 51-150kVA: 50dBA at 1.0m.
- .12 Electrical room layout has been based upon Hammond transformer dimensions. If an alternate manufacturer is selected from the Alternate Manufacturers List, the Electrical Subcontractor shall ensure that the alternate products will fit into the space allocated while maintaining the proper clearances.
- .13 Warrantee period shall be five years from date of Ready-for-Takeover.

#### 5.7 Grounding and Bonding

- .1 Include grounding and bonding as required by OESC, ESA Inspection Department, and as shown on drawings.
- .2 Provide a bond conductor from the electrical service entrance ground continuous to the following:
  - a. Transformers.

#### 5.8 Motor Protection and Control

- .1 General
  - a. Each starter shall include manual reset thermal overload elements, one for each power supply line, i.e., three for three-phase motors. Overloads shall be sized to suit the connected load.
  - b. All starters and disconnects shall be listed as "Suitable as Motor Disconnects".
  - c. All starters shall be NEMA rated with a minimum Size 0 and be rated at minimum 15A continuous current. IEC design starters shall not be permitted.
  - d. Motor starters shall be rated for minimum 10kA withstand rating and shall not be less than the available fault current.
- .2 Combination Starters

- a. Provide combination starters complete with fused disconnect switch protection suitable for use with Class J fuses.
- b. Provide two sets of normally open and normally closed extra auxiliary contacts in each starter for connection to the building automation system by the controls subcontractor.
- c. Integral control voltage transformer with fused secondary, rated for min 50VA. All control wiring and devices shall function on a 24VAC control circuit unless indicated otherwise.
- d. Thermal overload protection.
- e. Red pilot lamp indicating starter is energized.
- f. Door mount overload reset switch.

### 5.9 Execution

- .1 Wall mounted distribution equipment shall be mounted in an approved manner. The equipment shall be mounted in a well-organized and planned arrangement.
- .2 Concrete housekeeping pad shall be provided as outlined on plans.
- .3 Install disconnecting means within sight and less than 9m from motor loads.
- .4 Install disconnecting means within sight and less than 3m from air conditioning and refrigeration equipment.
- .5 Install transformers in level upright position.
- .6 Starters and disconnect switches installed in areas that are accessible by the public shall be lockable in the on and off positions.

## **6. 26 50 00 LIGHTING**

### 6.1 General

- .1 Supply and install lighting with all accessories and lamps as shown in "LIGHTING FIXTURE SCHEDULE," and as described.
- .2 Submit Shop Drawings containing the following information:
  - a. Picture of fixture, fixture model number, fixture colour.
  - b. Lens data, mounting details, photometric data.
  - c. Fixture manufacturer (include address and telephone number).
- .3 No allowance or change in fixture type will be permitted for the failure of the Electrical Subcontractor to allow sufficient time for the delivery of the fixtures when required to the site. Should the approved fixtures not arrive on time, this subcontractor shall supply and install temporary fixtures at no cost to the Owner and shall replace same with the approved fixtures when they arrive and make good all surfaces disturbed by this operation.

### 6.2 Alternative Fixtures

- .1 Any alternative fixtures proposed shall be demonstrated to provide an acceptable level of performance, construction and appearance to that of the units specified.
- .2 Post award, lighting simulations shall be prepared by the alternative manufacturer at their expense and submitted to the Engineer for review. After evaluation, if the alternate is deemed by the Engineer to be unacceptable, the alternative fixtures will be rejected and the equipment specified is to be provided.

### 6.3 Solid State (LED) Lighting

- .1 Quality Assurance
  - a. Luminaires shall be of uniform quality and appearance.
  - b. Manufacturers of LED luminaires shall demonstrate a suitable testing program incorporating high heat, high humidity and thermal shock test regimens to ensure system reliability and to substantiate lifetime claims.
  - c. The LED fixture assembly/manufacturing facility shall be ISO 9001 certified and produce product in compliance to RoHS.
  - d. At time of manufacture, electrical and light technical properties shall be recorded for each luminaire. At a minimum, this should include lumen output, CCT, and CRI. Each luminaire shall utilize a unique serial numbering scheme. Technical properties must be made available for a minimum of 7 years after the date of manufacture.
  - e. Luminaires shall be provided with a 5 year warranty covering, LEDs, drivers, paint and mechanical components.
- .2 Material and specifications for each luminaire are as follows:

- a. Each luminaire shall consist of an assembly that utilizes LEDs as the light source. In addition, a complete Luminaire shall consist of a housing, LED array, and electronic driver (power supply).
- b. Each luminaire shall be rated for a minimum operational life of 60,000 hours of operations at an average operating time of 10.5 hours.
- c. The rated operating temperature range shall be -40°C to +40°C.
- d. Photometry must be compliant with IES LM-79-19 and shall be conducted at 25°C ambient temperature.
- e. Each luminaire shall meet all parameters of this specification throughout the minimum operational life when operated at the average nighttime temperature.
- f. The individual LEDs shall be constructed such that a catastrophic loss or the failure of one LED will not result in the loss of the entire Luminaire.
- g. Luminaires shall be constructed such that LED modules may be replaced or repaired without replacement of whole Luminaire.
- h. Each luminaire shall be listed with CSA or cUL under UL1598 for luminaires.

.3 Electrical Requirements

- a. Maximum power consumption allowed for the Luminaire shall be determined by application. The Luminaire shall not consume power in the off state.
- b. The luminaire shall operate from a 60Hz  $\pm$ 3Hz AC line over a voltage ranging from 108VAC to 350VAC. The fluctuations of line voltage shall have no visible effect on the luminous output.
- c. The luminaire shall have a power factor of 0.90 or greater.
- d. Total harmonic distortion (current and voltage) induced into an AC power line by a luminaire shall not exceed 20 percent.
- e. The luminaire on-board circuitry shall include surge protection devices (SPD) to withstand high repetition noise transients as a result of utility line switching, nearby lightning strikes, and other interference.
- f. The LED circuitry shall prevent visible flicker to the unaided eye over the voltage range specified above.
- g. LED drivers must meet Class A emission limits referred in Federal Communications Commission (FCC) Title 47, Subpart B, Section 15 regulations concerning the emission of electronic noise.
- h. Drivers shall have a Class A sound rating.

.4 Photometric Requirements

- a. Optical assemblies shall have a minimum efficiency of 85% regardless of distribution type. All optical assemblies will be mounted parallel to the ground, aimed in the same direction and shall provide the same optical pattern such that catastrophic failures of individual LEDs will not constitute a loss in the distribution pattern.
- b. All photometric data will be measured by the IES LM-79-19 standard and formatted per IES LM-63-19 as an electronic .ies file.
- c. The illuminance shall not decrease by more than 30% over the expected operating life. The measurements shall be calibrated to standard photopic calibrations.
- d. The luminaire shall have a Correlated Colour Temperature (CCT) range of 3,000K to 4,500K as indicated in the Lighting Fixture Schedule. The colour rendition index (CRI) shall be 80 or greater.

- e. Exterior luminaires shall not allow more than 10 percent of the rated lumens to project above 80 degrees from vertical. The luminaire shall not allow more than 2.5 percent of the rated lumens to project above 90 degrees from vertical. Backlight and Glare ratings calculated as per IES TM-15-20.
- .5 Thermal Management
- a. The thermal management (of the heat generated by the LEDs) shall be of sufficient capacity to assure proper operation of the Luminaire over the expected useful life.
  - b. The LED manufacturer's maximum thermal pad temperature for the expected life shall not be exceeded.
  - c. Thermal management shall be passive by design. The use of fans or other mechanical devices shall not be allowed.
  - d. The luminaire shall have a minimum heat sink surface such that LED manufacturer's maximum junction temperature is not exceeded at maximum rated ambient temperature of 40°Celsius (supply Heat test).
  - e. The heat sink material shall be aluminum.
- .6 Physical and Mechanical Requirements
- a. The luminaire shall be a single, self-contained device, not requiring on-site assembly for installation. The power supply for the luminaire shall be integral to the unit.
  - b. The assembly and manufacturing process for the LED Luminaire shall be designed to assure all internal components are adequately supported to withstand mechanical shock and vibration from high winds and other sources.

#### 6.4 Exit Signage

- .1 All new exit signs shall conform to the performance of internally lighted exit signs standards as outlined in the Ontario Electrical Safety Code.
- .2 All new exit signs shall conform to the visibility and symbol specifications referred to in ISO 3864-1 and ISO 7010.
- .3 All exit signs shall be self-powered, i.e., with integral batteries.
- .4 Provide protective guards where indicated.
- .5 Fixture Features
  - a. Running man pictorial signs. Field modify pictograms as outlined.
  - b. Double-sided signs shall have two pictograms.
  - c. White, baked powder coat finish.
  - d. External LED status indicator and test switch.
  - e. Sealed Ni-Cad batteries for emergency illumination self-powered units.
- .6 Additional Vandal Resistant Features
  - a. 16 gauge steel backed with impact resistant polycarbonate face plates
  - b. Tamper resistant screws.

### 6.5 Execution

- .1 Provide all fastenings, supports etc. to install in an appropriate and approved manner. Adequately support all ceiling mounted fixtures, from the building structure. Use safety chains for all accessible ceilings. The accessible ceiling shall not solely support the fixture. The requirement for independent support for fixtures may be waived only if the accessible ceiling manufacturer provides written confirmation that the ceiling has been designed to carry the load.
- .2 Fasten fixtures to studs, joists, furring channel or other structural ceiling framing with screws. Drill holes in fixtures if required for alignment to ceiling structure. Coordinate with ceiling installed to ensure sufficient structure is provided for the fixtures. Toggle bolts or drywall anchors alone is insufficient.
- .3 All fixtures installed in/on acoustic tile in T-bar ceilings shall have safety chains. All fixtures recessed into T-bar ceilings shall be provided with grid clips, or fly-out tabs to restrict the fixture from being pushed up during maintenance.
- .4 All fixtures in T-bar ceilings shall be wired with sufficient spare conductor coiled in the ceiling to allow fixtures to be moved 4'-0", (1.2m) in any direction.
- .5 Recessed fixtures shall not be installed in an insulated ceiling unless approved for that installation.
- .6 Adjust fixture location onsite as required to avoid interference with swing of adjacent doors.
- .7 All cabling associated with lighting control system shall be CMP CAT5e green. Performance shall meet or exceed that of Nexans HyperPlus 5e Plenum Part Number 10032232.
- .8 Exit signs shall be wall or ceiling mounted to suit site conditions. Wall mounted exit signs shall be mounted at 96" (2430mm) above finished floor or 12" (300mm) above doors. Exit signs may be ceiling mounted if the ceiling height does not exceed 144" (3658mm). Exit signs location and mounting arrangements shall be coordinated onsite so that the fixture is visible from the exit approach. Modify location as required to ensure visibility.
- .9 Wall mounted light fixtures installed in corridors shall not protrude more than 4.0" (100mm) if any portion of the fixture is mounted below 78" (1.98m) above finished floor.
- .10 Coordinate position of lighting fixtures in mechanical areas with mechanical duct work and equipment. Modify installation to suit.
- .11 Suspended light fixtures in areas near ceiling fans or supply air diffusers shall be rigidly mounted, or suspended with two chains, set at an angle so as to eliminate sway.
- .12 The location of fixtures as shown on the drawings are approximately correct, but the Consultant reserves the right to alter the location of any number of them up to 120", (3.0m) without incurring extra costs, provided the request is made before the fixture is installed.

---

## **7. 26 52 13 EMERGENCY LIGHTING (UNIT EQUIPMENT)**

### 7.1 General

- .1 Supply and install an emergency lighting system consisting of the following, to activate and provide egress lighting in the event of a power failure:
  - a. 24VDC battery unit(s), lighting heads, conduit, wiring etc.
  - b. Battery-backed lighting fixtures, conduit, wiring etc.
- .2 Batteries to automatically recharge after normal power is restored.
- .3 Provide complete working system utilizing products as outlined in "LIGHTING FIXTURE SCHEDULE."
- .4 Equipment shall conform to CAN/CSA-C22.2 No. 141-10 (or latest edition).

### 7.2 Products

- .1 Self-Contained
  - a. High quality, corrosion, flame and vandal resistant, polycarbonate housing.
  - b. Vandal resistant latch clips.
  - c. Ceiling or wall mounted. Adjust the position of the LED board for all wall mount applications to direct lighting down.
  - d. IP65 rating. Suitable for wet location installations.
  - e. Auto-test circuitry. External test switch for momentary test operation.
  - f. Sealed Ni-MH batteries for minimum 90 minute emergency illumination.
  - g. Nine year pro-rata warranty on the assembly. Ten year battery warranty.
- .2 Remote Heads
  - a. Die cast heads with twist lock collar.
  - b. Fully adjustable with tilt and swivel.
  - c. LED lamps.
- .3 Battery Units
  - a. 18 gauge, ventilated steel enclosure.
  - b. Low gloss beige enamel corrosion resistant painted finish.
  - c. AC "ON" light (charging).
  - d. High charge light.
  - e. Test switch.
  - f. 60 cycle input, voltage as indicated, c/w fuse.
  - g. 120mm minimum u-ground plug and power cord for 120V systems, direct connection for 347V systems.
  - h. 24VDC output.
  - i. The battery shall be long life lead calcium type (maintenance free).
  - j. The capacity of the battery shall be in accordance with that shown in the "LIGHTING FIXTURE SCHEDULE."

- k. Battery to provide power to the fixtures for 90 minutes without dropping below ninety-one percent voltage drop.
- l. Charger to be solid state, with HI/LO charge indicator and capable of recharging in 24 hours.
- m. Provide suitable mounting brackets for safe and permanent mounting of the battery.

### 7.3 Execution

#### .1 DC System

- a. Battery pack to mount at 90", (2.3m) or above doors. Power feed for battery packs shall be mounted at 98", (2.5m) wherever practical. Provide connection from nightlight circuit.
- b. Wall mounted remote heads shall be mounted at 96", (2.5m) AFF or 12", (300mm) below ceiling whichever is lowest. Verify locations on site with Architect.
- c. Provide protective guards where indicated.
- d. Wire size shall limit voltage drop to five percent to the most remote fixtures.
- e. Provide T90 wiring in EMT. Use min #10AWG copper.
- f. All DC wiring shall be installed in an independent raceway.
- g. Provide lamicoid nameplate on each battery pack indicating area served. Refer to "LIGHTING FIXTURE SCHEDULE" for suggested labeling.
- h. Rooms required to contain emergency lighting shall have a minimum of two heads installed.

#### .2 Self-Contained

- a. Orient ceiling mounted fixtures perpendicular to axis of corridor.

#### .3 Refer to previous specification section for provision of spare emergency lighting parts.

#### .4 Perform an Emergency Lighting and Exit Sign test as soon as the systems are operational. Test shall indicate the following in chart form on Company letterhead:

- a. Building name and location.
- b. Physical location of each remote device.
- c. The device designation, i.e, EA, EXB, etc.
- d. Battery pack designation, manufacturer and name plate data.
- e. Proper operation under normal AC power.
- f. Duration of operation under emergency DC power.
- g. Current load check on each output circuit.
- h. Location and voltage at most remote fixture.
- i. Charging current at the end of the test.
- j. Date of testing.
- k. Signature and name of testing individual.

#### .5 Once system is free of defects, remove all AC and DC power sources at a time suitable to the Owner, so as to schedule subsequent self-diagnostic Auto-Tests for minimal distraction to building occupants.

**END OF SECTIONS**

## **1. 27 05 13 COMMON WORKS**

### 1.1 General Requirements

- .1 The Procurement and Contracting Requirements as outlined under Division 00, and the General Requirements as outlined under Division 01, and all addenda thereto shall apply to and govern all portions of the communications work.
- .2 Reference Division 26 and Division 28 for additional requirements.

### 1.2 Work to be Included in the Bid

- .1 The electrical subcontractor shall supply and install and/or modify the following systems:
  - a. Grounding and bonding.
  - b. Pathways for Communications and Security.
  - c. Audio/Video.
- .2 The work shall include all equipment, cabling, terminations, testing, programming, integration and commissioning as applicable.
- .3 The electrical subcontractor shall obtain the services of qualified communications subcontractor(s) for the satisfactory completion of the work, and shall carry all such subcontractor costs in the bid.
- .4 All rough-in work, including power and pathways, shall be performed by Division 26. All equipment, cabling, terminations, testing, programming, integration and commissioning and programming shall be performed by the appropriate Communications Subcontractor.
- .5 The communications subcontractor shall warrant any equipment installed under this specification to be free from defects for a period of two years from the date when Ready-for-Takeover has been attained.
- .6 The subcontractors shall ensure that all cabling in spaces being used as a return air plenum is totally enclosed in non-combustible raceways, or is Communications Media Plenum (CMP), or FT6 rated.
- .7 All systems and components shall be ULC listed.

### 1.3 Work by Allowance

- .1 The following systems shall be supplied and installed and/or modified under the specified allowance(s):
  - a. Computer (data)
  - b. Telephone (voice)
  - c. Public address.
  - d. Assistive listening.

- .2 The work shall include all equipment, cabling, terminations, testing, programming, integration and commissioning as applicable.
  
- .3 The electrical subcontractor shall coordinate with the successful Division 27 subcontractor(s) to provide all rough-in work, including power and pathways.

## **2. 27 05 26 GROUNDING AND BONDING**

### 2.1 Grounding and Bonding

- .1 Grounding Connections:
  - a. Compression type, two hole, long barrel, two crimps.
  - b. Panduit LCC6-14JAW-L, size to suit conductor.
  - c. Panduit HTAP kit # HTWC6-6-1, size to suit conductor.

---

### **3. 27 05 28 PATHWAYS FOR COMMUNICATIONS AND SECURITY SYSTEMS**

#### 3.1 General

- .1 This section will generally refer to empty conduits, sleeves, junction boxes, etc. associated with the following systems:
  - a. Communications, i.e., structured cabling, Information Technology (IT), telephone (voice), television, public address, clock, audio/visual and assistive listening.
  - b. Electronic Safety and Security, i.e., intrusion alarm and access control.
- .2 Provide all material and labour necessary for a complete installation of pathways.

#### 3.2 Installation - Interior

- .1 Unless otherwise noted, all outlets shall be single gang deep boxes. Each single gang box shall be provided with 0.75" (21mm) conduits. Outlets that indicate more than two drops shall feature 1.0" (27mm) conduits. Allow for punching holes in metal outlet boxes if available knockouts cannot meet this specification.
- .2 All conduit runs shall follow building grid lines and shall be concealed. Conduits installed below the floor slab need not follow building grid lines.
- .3 Conform to the following conduit installation restrictions:
  - a. 200', (61m) maximum - no bends.
  - b. 150', (45m) maximum - one 90 degree bends.
  - c. 100', (30m) maximum - two 90 degree bends.
  - d. 65', (20m) maximum - three 90 degree bends.
  - e. No more than 3 - 90 degree bends in a conduit run are allowed.
  - f. 2.0", (50mm) conduit or smaller - 6x diameter bending radius.
  - g. 2.5", (64mm) conduit or larger - 10x diameter bending radius.
- .4 EMT bushings shall be Arlington AL-EMTxx series, size to suit conduit specified.
- .5 If the conduit lengths/bends exceed that listed above, a pull box shall be installed.

#### 3.3 Specific Rough-ins

- .1 Rough-in for exterior card readers shall be 6x6" (150x150mm), standard depth boxes. Provide smoked, beveled lexan cover. Interior rough-ins may be flush mounted on single gang box with an extended back plate.
- .2 Coordinate with the Communications Subcontractor to procure public address speaker back boxes for any wall or drywall ceiling installations.
- .3 Unless otherwise noted, boxes for audio/video inlets/outlets shall be two-gang.

#### 3.4 Self-Sealing Conduit Sleeves

- .1 All conduit sleeves through a rated separation shall consist of an enclosed, fire-rated pathway device. The CUL Classified/FM Approved pathway shall contain a built-in fire sealing system sufficient to maintain the hourly fire rating of the wall or floor being penetrated. The self-contained sealing system shall automatically adjust to the installed cable loading and shall permit cables to be installed, removed, or retrofitted without the need to adjust, remove, or reinstall firestop materials. The pathways shall be Specified Technologies Inc. EZ-Path, or approved alternate, in the following configurations:
  - a. Series 44 for ganged sleeves through 6.0" (153mm) cored holes. Standard length is 14" (356mm).
- .2 Provide wall plates, gang kits (extensions), conduit attachment kits, and retrofit kits as required.

### 3.5 Cabling Hangers

- .1 Multiple use "J" shaped hanger to provide secure containment of low voltage communications cables.
  - a. Pre-galvanized finish.
  - b. 4" (100mm) size capable of supporting 300 4-pair UTP, CAT5e or 2-strand fibre cable, or 185 CAT6.
  - c. Quick release cable retainer.
- .2 Hangers shall be Cooper B-Line Catalog No. BCH64 series, or approved alternate, complete with Qwik-Latch cable retainers.
- .3 Units shall be wall mounted (-1D) where ever possible. Where not possible, units shall be suspended from the structure (-2D).
- .4 Installation of power wiring in hangers shall not be permitted.
- .5 Hangers shall be spaced at 40" (1.0m) intervals.
- .6 Coordinate exact location of hangers onsite with Mechanical Contractor to avoid conflicts with piping, ductwork etc.

### 3.6 Execution

- .1 Provide a conduit from each outlet box to the nearest accessible ceiling space. Conduit shall extend minimum of 6.0" (150mm) above ceiling and shall have smooth 90 degree bends. Do not terminate conduits above non-accessible ceiling systems.
- .2 Conduits for Assistive Listening cabling is recommended to be contained within each room (not stubbed to the corridor). Maximum of 15m cable lengths.
- .3 Provide a blank cover plate on each outlet of the same colour and material as described in the wiring devices section.
- .4 Provide at 0.75" (21mm) conduit continuous to each Point of Sale terminal.

- .5 All empty conduits and raceway systems shall be provided complete with nylon pull tapes and plastic bushings.
- .6 Pull tapes shall be suitably fastened to the ends of each conduit to prevent accidental pull outs.

#### **4. 27 40 00 AUDIO/VIDEO**

##### 4.1 Scope of Work

- .1 The Electrical Subcontractor shall provide the audio/video systems in classrooms.

##### 4.2 Video Products

- .1 Projectors and associated mounting hardware shall be supplied in-contract, complete with associated remote control and batteries, all for installation by the Electrical Subcontractor.
- .2 Projection screens shall be provided by others.
- .3 Provide the following in a typical teaching space:
  - a. Custom stainless steel decora strap with female HDMI input and female 3.5mm audio input.
  - b. HDMI cable.
    - i. Plenum rated (CMP).
    - ii. Length to suit, but less than 15m.
    - iii. 10.2 Gbps bandwidth.
    - iv. 24 AWG.
  - c. Adjustable Projector Drop Pole: Chief CMS Series. Provide suitable length pole such that the projector is level with the top of the screen.
  - d. Projector Mount: Chief RPAU-W.
  - e. Mounting Plate: Chief CMS440. Fasten safety cable to structure.
  - f. Plenum Rated Box: Chief CMA470. Secure to top of mounting plate.
  - g. Projector: WXGA laser projector Optoma Model ZW400 complete with remote control and batteries.

##### 4.3 Video Execution

- .1 Installations instructions shall be obtained from the system manufacturer prior to installation.
- .2 Prior to installation, verify optimal distance from projectors to screen with projector manufacturer's specifications. Based on proposed equipment, maintain 3660mm (12ft) between projector and screen. Projector shall be no more than 100mm (4") off centre of the screen.
- .3 Mount duplex receptacle above finished ceiling to power the projector.
- .4 Provide CMP HDMI cable from the projector to the video outlet. Refer to the floor plans for the location of the video outlet.
- .5 All projectors are subject to ambient light conditions. It is recommended lighting and window coverings be adjusted for optimal projector performance.

#### **END OF SECTIONS**

## **1. 28 05 00 COMMON WORKS**

### 1.1 General Requirements

- .1 The Procurement and Contracting Requirements as outlined under Division 00, and the General Requirements as outlined under Division 01, and all addenda thereto shall apply to and govern all portions of the electronic safety and security work.
- .2 Reference Division 26 and Division 27 for additional requirements.

### 1.2 Work to be Included in the Bid

- .1 The electrical subcontractor shall supply and install and/or modify the following systems:
  - a. Access control.
  - b. Fire detection and alarm.
- .2 The work shall include all equipment, cabling, terminations, testing, programming, integration and commissioning as applicable.
- .3 For the access control & intrusion detection scope, the electrical subcontractor shall retain the services of one of the following alphabetical list of security subcontractors, and shall carry all such subcontractor costs in the bid:
  - a. Chubb Security Systems [www.en.chubbedwards.com](http://www.en.chubbedwards.com)
  - b. G&A Lock & Security (William Knell & Company Limited) [www.galock.ca](http://www.galock.ca)
  - c. STC Systems Inc. [www.stcsystems.ca](http://www.stcsystems.ca)
- .4 All rough-in work, including power and pathways, shall be performed by Division 26.
- .5 The security subcontractor shall warrant any equipment installed under this specification to be free from defects for a period of two years from the date when Ready-for-Takeover has been attained.
- .6 The subcontractors shall ensure that all cabling in spaces being used as a return air plenum is totally enclosed in non-combustible raceways, or is Communications Media Plenum (CMP), or FT6 rated.
- .7 All systems and components shall be ULC listed.

## **2. 28 10 00 ACCESS CONTROL**

### 2.1 Scope of Work

- .1 The subcontractor shall be responsible for modification of the existing access control system including the supply and installation of all equipment, cabling, and field devices
- .2 All final terminations and programming shall be performed by the manufacturers authorized representative.
- .3 The subcontractor is to coordinate with Owners staff for the start-up of the systems.

### 2.2 Quality Assurance

- .1 The subcontractor shall have a factory trained service department on call twenty-four hours a day, 365 days a year, to service the specified product.
- .2 The installing subcontractor may be asked to provide a reference list of five similar sized projects installed by the subcontractor including contacts and telephone numbers.

### 2.3 Products

- .1 Door Controller
  - a. Verex Part Nos. 120-8206 (2 door), 120-8510 transformer (18VAC, 37VA) and 120-8500 rechargeable batteries (12V, 7.5Ah).
  - b. Procure new if practical. Provide refurbished if new unavailable.
  - c. Wall mount adjacent to existing.
- .2 Proximity Readers
  - a. Verex G-Prox III proximity reader with 10' (3m) cable.
    - i. Switch plate Verex No. 120-6431. Recess and provide smoked lexan cover plate for all exterior applications.
  - b. Cards/tokens shall be provided by the Owners.
- .3 Cabling
  - a. Communications Bus: 4-conductor, shielded, purple, CMP from control panel to each door controller. Cable shall not be T-tapped or Star-tapped.
  - b. Proximity Reader: 6-#24AWG green CMP cable from the door controller.
  - c. Electric Strike Power: 2-#18AWG brown CMP from the door controller.
  - d. Power Door Operator: 4-#18AWG white for constant 12VDC from door controller.
- .4 Door strikes by others.
- .5 Power door operators by others.

### 2.4 Execution

- .1 Cut and patch existing construction as required to install the new access controls at Stair 908. Wall finishing by others.
- .2 Provide integration between power door operator controls and proximity readers.
- .3 Provide pathways and cabling to all products, including components provided by others.

#### 2.5 Programming

- .1 Coordinate with owners' personnel for all programming. The programmer shall confer with the owner's personnel to determine the optimal setting of each programming option.

#### 2.6 Field Quality Control

- .1 The work of this section shall not be considered to be complete until all systems and component parts have been tested and found to be in satisfactory operating condition.

### **3. 28 46 00 FIRE ALARM AND DETECTION**

#### 3.1 Scope of Work

- .1 This specification provides the requirements the modification of the existing addressable fire alarm and detection system.

#### 3.2 Quality Assurance

- .1 Edwards has been specified as the manufacturer and as such, sets the standard of quality and type of equipment to be provided.
- .2 Each and all items of the fire alarm and detection system shall be covered by a one-year parts and labour warranty covering defects resulting from faulty workmanship and materials.
- .3 All equipment shall be new and unused. All components and systems shall be designed for uninterrupted duty. All equipment, materials, accessories, devices, and other facilities covered by this specification or noted on contract drawings and installation specifications shall be the best suited for the intended use and shall be provided by a single manufacturer or if provided by different manufacturers recognized as compatible by both manufacturers and ULC.
- .4 Installing contractor shall be certified by a program or course acceptable to the Office of the Fire Marshal. Evidence of membership in the ECAO Fire Alarm and Protection Certification Program, or proof of registration as a CFAA Fire Alarm Technician may be requested.

#### 3.3 Control Panel (FACP)

- .1 The existing fire alarm control panel shall remain.
- .2 The system program shall meet the requirements of this project, current codes and standards, and satisfy the local authority having jurisdiction.
- .3 Provide optional relay cards as required to support all ancillary devices and equipment as described herein.
- .4 Notification Appliance Circuits:
  - a. Provide new as required, supervised hard-wired Notification Appliance (Signal) Circuits (NAC) for the control of 24VDC notification appliances. Each NAC shall operate as Class B power limited circuit.
  - b. NAC's shall be capable of providing steady, 20bps, 120bps or temporal rate outputs.
  - c. The quantity of NAC's shall be adequate to support all signaling devices indicated on the plans with no NAC loaded beyond 65%, regardless of the zoning arrangement indicated on the plans.

#### 3.4 Remote Annunciators

- .1 Existing annunciator(s) shall remain. Modify to reflect the new zoning arrangement.

#### 3.5 Passive Graphic

- .1 Updated passive zoning graphic(s) shall be provided by others.

### 3.6 Addressable Initiating Devices

- .1 Addressable Devices
  - a. Each remote device shall have a microprocessor with non-volatile memory to support its functionality and serviceability.
  - b. Each device shall be capable of electronic addressing, either automatically or application programmed assigned, to support physical/electrical mapping and supervision by location.
- .2 Addressable Detectors
  - a. The system addressable detectors shall be capable of full digital communications using both broadcast and polling protocol.
  - b. Each detector shall have an integral microprocessor capable of making alarm decisions based on parameter information stored in the detector head.
  - c. Each detector shall have a separate means of displaying communication and alarm status.
  - d. The detectors shall be suitable for mounting on any Signature Series detector mounting base.
  - e. The addressable detectors and devices shall be as follows:
    - i. Smoke and Heat, SIGA-OSHD.
    - ii. Heat Rate-of-Rise, SIGA-HRD. (57C)/Rate of Rise (9C per minute).
    - iii. Heat Fixed, SIGA-HFD.
    - iv. Duct Smoke, SIGA-SD. Provide sampling tube and remote alarm LED.
    - v. Zone Isolator, SIGA-IM2.
  - f. All addressable detectors shall be suitable for use with the following bases:
    - i. Standard, SIGA-SB.
- .3 Addressable Modules
  - a. It shall be possible to address each Intelligent Signature Series module without the use of DIP or rotary switches.
  - b. The personality of multifunction modules shall be programmable at site to suit conditions and may be changed at any time using a personality code downloaded from the Analog Loop Controller.
  - c. Input and output circuit wiring shall be supervised for open and ground faults.
  - d. The addressable module devices shall be as follows:
    - i. Control Relay, SIGA-CRH (form C contacts, 6A @24VDC, 7A @120VAC).
    - ii. Dual Input, SIGA-CT2.
    - iii. Manual Station, SIGA-270.

### 3.7 Conventional Initiating Devices

- .1 The system shall possess the capability of incorporating the following conventional system devices:
  - a. Moisture Proof Fixed Temperature Heat Detectors, CF135MP.

### 3.8 System Accessories

- .1 Provide independent devices as follows:
  - a. Addressable Fire Detector Guard, SIGA-GRD. Include mounting flange where required.
  - b. Conventional Heat Detector Guard, Model No. 1206B.
  - c. End of line device cover plates, Model No. EOL-P1, white.

### 3.9 Signaling Devices

- .1 All appliances shall be ULC Listed for Fire Protective Service.
- .2 All appliances shall be of the same manufacturer as the Fire Alarm Control Panel to ensure absolute compatibility between the appliances and the control panels, and to ensure that the application of the appliances is done in accordance with the single manufacturer's instructions.
- .3 Signaling pattern and sound shall be consistent throughout the facility. Mixing of different sounding devices shall not be permitted.
- .4 Horns
  - a. Genesis model G4ARF, red, wall mounted, field selectable audibility.
- .5 Horn/Strobes wall mounted
  - a. Genesis model G4AVRF, red, wall mounted, field selectable audibility and light intensity levels (15, 30, 75, 110cd).

### 3.10 Fire Alarm Monitoring Equipment (FAME)

- .1 Existing panel shall remain to allow for offsite monitoring of the fire alarm and detection system.

### 3.11 Sequence of Operation

- .1 The system shall function so that operation of any alarm initiating device shall cause the following:
  - a. Signal devices to operate throughout building at the evacuation alert rate.
  - b. Transmit an alarm signal to remote monitoring agency.
  - c. Display an event type, alarm time, and a location message for each active device or zone at control panel and at remote annunciators.
- .2 The system shall function so that operation of any supervisory initiating device shall cause the following:
  - a. Internal signal to sound at the control panel and remote annunciators.

- b. Display a location message for active device(s) at the control panel and remote annunciators.
  - c. Transmit a supervisory signal to remote monitoring agency.
- .3 Program interlocks with all ancillary equipment as follows:
- a. Door holders: Release on alarm.
  - b. Smoke dampers: Close on alarm or any smoke detector associated with the damper or the associated air handling unit.
  - c. Air handling system: Shut down on alarm or local duct smoke detector or any fire smoke damper associated with this particular system.
  - d. For equipment and system interlocks not referenced above, contact consultant for clarification.
- .4 Program initiating devices as follows:
- a. Alarm:
    - i. Smoke detectors.
    - ii. Heat detectors.
    - iii. Manual stations.
    - iv. Sprinkler Flow Switches (FS), (60s delay).
    - v. Kitchen hood fire suppression.
  - b. Supervisory:
    - i. Sprinkler Electronically Supervised Valves (ESV).
  - c. For equipment system interlocks not referenced above, contact consultant for clarification.
- .5 Indicate trouble condition at control panel and remote annunciator(s) for the following conditions:
- a. Field wiring open circuit.
  - b. Field wiring ground fault.
  - c. Battery disconnect.
  - d. Low battery.
  - e. AC power failure.
- .6 Equipment beneath kitchen hood shall shut down only upon a signal from the local fire suppression system completely independent of the fire alarm system. Do not connect equipment to shut down upon an alarm from the fire alarm system. Kitchen equipment shall continue to run on an alarm condition until such point that the suppression system is activated.
- .7 Program signal devices as follows:
- a. Single two stage operation.
  - b. Temporal 3-3-3 pattern for alarm.
  - c. Set at maximum volume unless noted otherwise. Adjust to lower volume settings only if maximum permitted threshold is exceeded.

- .8 Duct detectors and smoke detectors associated with adjacent smoke dampers shall be programmed to activate the initiating zone on the floor where the device is located and the associated air handling equipment zone.

### 3.12 Installation

#### .1 General Installations

- a. The entire system shall be installed in accordance with CAN/ULC-S524-19 and approved manufacturers manuals and wiring diagrams. The Electrical Subcontractor shall furnish all conduit, wiring, outlet boxes, junction boxes, cabinets and similar devices necessary for the complete installation. All wiring shall be of the type recommended by the OESC, approved by local authorities having jurisdiction for the purpose, and shall be installed in dedicated conduit throughout.
- b. All penetration of floor slabs and fire walls/separations shall be fire stopped in accordance with all local fire codes.
- c. Install all initiating circuit wiring and all signal circuit wiring in separate raceways.
- d. End of Line resistors shall be furnished as required for mounting as directed by the manufacturer. Lamacoid labels shall be fastened to the front face of each EOL.
- e. Panel and annunciator zone labels shall be typed. Hand written labels shall not be permitted.
- f. Provide all programming and labels that reference room names or numbers to reflect the finalized Owner designated room names/numbers. Do not duplicate the room names/numbers indicated on the drawings.
- g. All wiring shall be minimum #14 AWG copper with 300V insulation rating, unless specifically noted otherwise.
- h. All device outlet boxes shall be selected to suit manufacturer's equipment and shall be coordinated prior to rough in. Outlet boxes for manual stations shall be 100mmx100mm (4"x4") with single gang plaster ring and depth to suit manufacturer's requirements.
- i. Provide clear adhesive labels with black lettering not more than 5mm high for fire alarm devices as follows:
  - i. On the cover plate of each signaling device to identify the circuit.
  - ii. On the cover plate of each end of line resistor to identify the circuit or zone.
  - iii. On the base of each addressable initiating device to identify the device address.
  - iv. On the base of each conventional initiating device to identify the zone.
  - v. On the cover plate of each module to identify the device address and function (i.e. relay, input, isolator, etc.).
  - vi. Pull stations do not require labels.
- j. Refer to previous specification section for provision of spare fire alarm and detection parts.
- k. Allow for the installation of all spare parts as identified above in locations to be determined by local building officials at the end of the project. Allow for verification of additional devices even if main verification has already been completed. If devices are not required to be installed, they shall be returned to the Owner as spare parts.
- l. If fire alarm remote booster power supplies are provided in lieu of extension of the power supply in the main panel, it shall be provided with internal back up batteries connected to the 120VAC life safety emergency power source. The breaker shall be

painted red and locked on. Use spare breakers in life-safety emergency panels for this purpose. Power wiring shall be 2.0hr fire rated. As-built drawings shall be modified to suit.

.2 Initiating Installations

- a. Locate and install all isolation modules and connect to data loop wiring.
- b. Locate and install all initiating circuits and detectors and connect to zone wiring.
- c. Install spot type fire detectors on ceiling unless otherwise specified herein with minimum and maximum distances as required for the respective type of detector.
  - i. Mount at highest point where variations in ceiling height exist.
  - ii. Maintain a clear space of at least 18" (450mm) on the ceiling, below and around the fire detector.
  - iii. Maintain a horizontal minimum of 36" (900mm) between a fire detector and the peak of a sloped ceiling.
  - iv. Fire detectors shall not be located a direct air flow or within 18" (450mm) from an air supply or exhaust outlet.
- d. Install duct detector sampling tubes in straight section of duct to manufacturer's recommendation. Install so that the smoke detector and sampling tube are accessible for servicing. Obtain actual duct dimensions onsite prior to ordering air sampling tubes.
- e. Manual stations shall be located within 1500mm (60") of an exit door. Where possible, locate on the latch side of a single door.
- f. Locate manual stations on mullions or other suitable structure to maintain this distance.
- g. Connect all waterflow alarm switches and sprinkler supervisory devices, supplied by Division 21, to zone wiring. Coordinate exact device locations and quantities on site.
- h. Verify the exact locations and names of all sprinkler system switches and valves with the Fire Protection Subcontractor onsite and modify zone names to suit.
- i. All Electronically Supervised Valves (ESV), Flow Switches (FS), and Low-Pressure Switches (LPS) shall be supplied and installed by the Fire Protection Subcontractor and wired by the Electrical Subcontractor. Coordinate exact quantities on site.

.3 Signaling Installations

- a. Locate and install all signaling devices and connect to notification circuit. Provide suitable back boxes and back plates for signaling appliances, surface or recessed type to suit the specific application.
- b. Provide adequate signal circuit wiring so that circuits are not loaded beyond 65%, regardless of the zoning arrangement indicated on the plans.
- c. Notification devices shall be set for temporal 3-3-3 pattern at maximum volume, unless noted otherwise.
- d. Programming for signal silence inhibit at 1.0 minutes, and automatic signal silence at 20 minutes.
- e. Install Signal Master Module on each signal circuit to synchronize output signals of horn/strobe combinations with one pair of conductors.
- f. Visual notification devices shall be set for 30cd, unless noted otherwise.

3.13 Addressable System Notes

- .1 Locate and install all isolation modules and connect to data loop wiring. Locate zone isolators directly adjacent to zone separation at the point where it enters and exits the zone. There shall be a minimum of two zone isolators for each initiating zone. The location of the isolators may be adjusted onsite to optimize wiring. Clearly indicate isolator location on as-built drawings.
- .2 Data loop wiring shall be ULC S524 Style C.
- .3 Data loop wiring shall exit/enter the control panel separate raceways and shall be separated 1.2m horizontally and 0.3m vertically thereafter.
- .4 The following OBC zones need not have zone isolators:
  - a. Sprinkler ESV, FS, LPS.
  - b. Duct smoke detectors.
  - c. Other devices that are situated completely within a floor area.
- .5 Data loop home run shall be permitted to pass through OBC zone/floor area/shafts without zone isolators. If devices are installed on the home run data loop, additional zone isolators shall be provided. Floor plans assume additional isolators will not be required.
- .6 Addressable sensors and modules shall be connected directly to the data loop wiring. T-tapping off the data loop to form a Class "B" (zone wiring) circuit shall not be permitted.
- .7 Zone wiring shall be #14/2 copper in a metallic raceway. AC90 (BX) cable is acceptable where specified. In all cases, the sensors and modules shall be located between the isolators serving the particular zone.
- .8 Ensure data loop device count does not exceed 80%. Provide additional data loops if required. Proposed zone layout shall be prepared by the manufacturer and submitted to the Consultant for review.
- .9 The address of each sensor and module shall be assigned by means of computer polling of the data loop(s) once installations are complete. The Electrical Subcontractor shall ensure that each addressable detector and module is assigned an identifying name in accordance with its installed location upon project completion.
- .10 All signaling devices shall be fed direct from the control panel using Notification Appliance Circuits (NAC)s. NAC wiring shall be #14/2 copper in metallic raceway. AC90 (BX) cable is acceptable where specified.
- .11 Connect addressable relay module outputs to the data loop nearest the module.
- .12 Field measure all loads connected to addressable relay modules where the ratings on contacts is exceeded, provide additional relay suitable for the connected load.

### 3.14 Field Quality Control and Programming

- .1 Perform verifications in accordance with CAN/ULC-S537-19 Standard for the Verification of Fire Alarm Systems. Include inspections and testing as outlined in CAN/ULC-S536 latest addition.

- .2 Perform audibility tests if required by the local Building officials or if requested by the consultant.
- .3 Check annunciator panels to ensure zones are shown correctly.
- .4 The system shall be installed and fully tested under the supervision of trained manufacturer's representative. The system shall be demonstrated to perform all the functions as specified.
- .5 Verification(s) shall be performed by the manufacturer's representative authorized by the CFAA. Verification by the Contractor shall not be permitted.
- .6 Include for multiple verifications and integrated tests where the construction schedule warrants. Coordinate exact requirements with General trades.
- .7 System installation and operations shall be verified by the manufacturer's representative and a verification document presented upon completion. The manufacturer's representative shall be responsible for an on-site demonstration of the system operation and initial staff training as required by the Architect and/or Consulting Engineer.
- .8 Changes made to an existing fire alarm system shall require the following:
  - a. Verification of all new and modified devices.
  - b. Testing of all devices on the data loops affected. Software polling of devices on modified data loops shall not be acceptable.
  - c. Testing of one device on each zone data loop not affected.
- .9 System changes shall be verified by the manufacturer's representative and a verification document presented upon completion.

### 3.15 Integrated Systems Testing of Fire Protection and Life Safety Systems

- .1 The Electrical Subcontractor shall retain the services of an Integrated Testing Coordinator (ITC) for all systems that are designed to operate together to achieve an overall fire protection and life safety objective, in accordance with OBC 3.2.9.
- .2 The Contractor shall not act as the ITC. The ITC shall be an independent provider that has been certified by ULC to perform this function and shall provide proof of certification prior to proceeding.
- .3 The Electrical Subcontractor shall cover the costs of the ITC and shall be responsible for coordinating and scheduling all affected parties including owners, operators, occupants, inspectors, consultants, installing subcontractors and verifying parties to participate in the testing.
- .4 The ITC shall be knowledgeable and experienced in the design, installation and operation of fire protection and life safety systems as well as associated building systems.
- .5 The ITC shall provide a project-specific, written report outlining the testing procedure and necessary functional results in accordance with CAN/ULC-S1001. A cause and effect matrix shall be used to outline the sequence of operation for the systems integration. The matrix

shall be prepared by the ITC based on sequence of operation and fire alarm drawings and schematics. Specifically, this integrated testing plan shall outline the fire alarm system's integration with the following equipment and systems:

- a. Sprinkler.
  - b. Cooking Equipment Fire Suppression.
  - c. Hold-open Devices.
  - d. Smoke Control, Air Handling.
- .6 Submit the integrated testing plan to the Engineer concurrently with shop drawings. Prior to testing, the Contractor shall provide all occupancy-related documentation to the ITC.
- .7 Unless otherwise outlined, the testing procedure shall consist of the functional operation of the device or system, i.e., testing of relay contacts alone is insufficient. Sample testing is also insufficient.
- .8 Once testing is completed, the ITC shall provide a signed report documenting the implementation of the systems integration. Include the report in the project close out for subsequent periodic systems testing as required.

**END OF SECTIONS**

# **26-7859-RFT - Waterloo-Oxford District Secondary School Window Replacements, Interior Alterations and HVAC Upgrades**

Opening Date: March 27, 2026 4:00 PM

Closing Date: April 21, 2026 2:00 PM

---

## Schedule of Prices

\* Denotes a "MANDATORY" field

Do not enter \$0.00 dollars unless you are providing the line item at zero dollars to the Board.

## Bid Price Form

The amounts stipulated on the Bid Price Form(s) are intended to cover the cost of the complete Work as described in this Procurement and must remain fixed and firm for the term of the Contract unless otherwise specified in this Procurement.

All prices shall be in Canadian Funds, Free On Board (FOB) Destination, and Freight Prepaid (Board locations). and shall be exclusive of Harmonized Sales Tax (HST) but shall include all materials, labour, equipment, disbursements, expenses, insurance, bonding, customs charges, freight, shipping and handling costs, travel costs and all other charges of every kind attributable to the Work and Services provided.

## Bid Price includes Cash Allowance

Line Item	Description	Unit of Measure	Quantity	Bid Price *	Total
1	As per scope of work outlined in 26-7859-RFT Waterloo-Oxford District Secondary School Window Replacements, Interior Alterations and HVAC Upgrades.	Lump Sum	1		
Subtotal:					

## Summary Table

Bid Form	Amount
Bid Price Form	
HST (13%)	\$ 0.00
Total Contract Amount:	

## Bid Questions

### Bidder Instructions

Answer all questions that are marked Mandatory.

Bill S-211 - This enactment enacts the Fighting Against Forced Labour and Child Labour in Supply Chains Act, which imposes an obligation on certain government institutions entities to ensure measures are taken to prevent and reduce the risk that forced labour or child labour is used by suppliers or in their supply chains. The Board principles align with Bill S-211. Please confirm that your organization will comply with this Act. YES or NO. If no, please explain.

As per the "Ontario Business" definition as per the BOBI Act is a supplier, manufacturer or distribution of any business structure; conducts its activities on a permanent basis in Ontario; and has either a) its headquarters or main office in Ontario, or b) at least 250 full-time employees in Ontario at the time of the applicable procurement process. Does your company qualify as an Ontario Business under the BOBI Act? YES or NO

is your company a Canadian business? YES or NO

Is your company a U.S. business, as defined by the Ontario Treasury Board / Management Board of Cabinet (TB/MBC) as a supplier, manufacturer or distributor of any business structure (includes a sole proprietorship, partnership, corporation or other business structure) that: has its headquarters or main office located in the U.S., and has fewer than 250 full-time employees in Canada at the time of the applicable procurement process? Yes or No. (Comments are allowed).

## Specifications

### Bidder's Contact Information

A Project Manager and Site Supervisor to manage and supervise the Work, must be named in this form. A dedicated Site Supervisor shall be in full-time attendance at the Place of the Work while the Work is being performed. Personnel will be subject to Board approval and may not be changed without prior written approval from the Board.

Note: resumes are required to be uploaded in the document section.

Title	Name	E-mail	Cell Phone Number	
Project Manager				*
Site Supervisor				*

## Documents

It is your responsibility to ensure the uploaded file(s) is/are not defective or corrupted and are able to be opened and viewed by the Owner. If the attached file(s) cannot be opened or viewed, your Bid Submission may be rejected.

### Instructions to Bidders

Upload a resume for each person named in the Specification section.

- Project Manager \* (mandatory)
- Site Supervisor \* (mandatory)
- Certificate of Recognition (COR) Certification \* (mandatory)

## **BONDING UPLOAD SECTION**

Refer to the Bonding Requirements Section of the Terms and Conditions.

### **Instructions to Bidders**

Bidders shall upload their electronically verifiable and enforceable (e-Bond) format for Bid Deposit Bond and Agreement to Bond separately in this section. If both Bonds are in the same file, please upload it to both fields and indicate one is a copy.

Tender # and Project Title must be included on the Bonds.

Bonding requirements are based on the total base bid amount, inclusive of all applicable taxes.

- Bid Deposit Bond \* (mandatory)
- Agreement to Bond \* (mandatory)

## Addenda, Terms and Conditions

I/We have read and understand this Bid Solicitation document, and agree to perform the Work required in accordance with this Bid

Solicitation document, including all addenda, at the price(s) detailed in the Bid.

I/We confirm that:

1. The person named in this Bid is authorized to sign and electronically submit this Bid through the Bidding System.
2. I/We meet all mandatory requirements of the Bid Solicitation document.
3. The bid will remain open for a specified acceptance period after the Closing Time. The Board may, at any time within this period, accept the Bid whether or not any other Bid has previously been accepted.
4. All prices provided in the Bid will remain fixed and firm for the duration of the term of the agreement, unless specified otherwise.
5. All prices provided in my/our Bid are in Canadian funds and include all charges of every kind attributable to the Work. Harmonized Sales Tax will be extra and not shown, unless specified otherwise.
6. To the best of my/our knowledge and belief:
  - a) the information provided in the Bid is correct; and
  - b) the Bid is made without any comparison of figures or arrangement with any other individual, corporation or person submitting a Bid for the same Work and is in all respects fair and without collusion or fraud.
7. I/We comply with the all applicable Board policies, provincial, and federal laws, and are aware of the Board's "Principles of Business Conduct" and will comply.
8. I/We agree and understand that the recommendation to award the Work may be subject to the approval from the Board as well as availability of funds.
9. I/We agree to be bound by the terms and conditions of the Bid Solicitation document and submit this Bid on behalf of the Bidder.

I have the authority to bind the Bidder.

The Bidder/Proponent is to declare any actual, potential or perceived conflict of interest that could arise from submitting the Bid/Proposal.

Do you have a potential conflict of interest?

Yes  No

The Bidder acknowledges and agrees that the addendum/addenda below form part of the Bid Solicitation Document.

Please check the box in the column "**I have reviewed this addendum**" below to acknowledge each of the addenda.

**File Name**

**I have reviewed the  
below addendum and  
attachments (if  
applicable)**

**Pages**

**There have not been any addenda issued for this bid.**