

Addendum #1

Issued June 27, 2024

The following information changes the competitive process documents issued on June 20, 2024.

GENERAL INFORMATION

Item 1: See 'Geotechnical Investigation and Limited Chemical Testing Program' dated February 2018 issued by Peto MacCallum Ltd. (57 pages)

Item 2: See 2024-155-P01964 Rosedale Civil Drawings' dated March 28, 2024 issued by MTE Consultants (3 pages)

QUESTIONS AND RESPONSES

Q1 Specification book provides interior signage section for washroom signs, however there is no signage schedule neither any washroom are shown on the drawings. please clarify where the signage is going and provide signage schedule.

R1 **Correct, no washroom signs in this project. As noted on plans, most door receive Sign Type 3 (door ID tag). Also noted on the plans, some doors receive a Room I.D. sign (one of Types 4 through 5A). See enclosed additional signage diagrams for clarification.**

Q2 There are two specification sections for window shades, one for motorized window shades and another one for manual. Specification sections do not states where each type of shades should be installed. Drawings do not indication neither locations of each type. We can assume location of motorized window shades based on electrical drawings; however, we need a clear direction where each type should be installed. Please provide locations of each type of shades.

R2 **Motorized blinds to be installed at all six windows in Learning Commons 125 and Resource Room 125A. Manual blinds to be installed at all four windows in Office 125B and Breakout Room 125C.**

Q3 Would you please issue geotechnical report?

R3 **See attached "Geotechnical Investigation and Limited Chemical Testing Program" report issued by PML Peto MacCallum Ltd. Consulting Engineers dated February 2018.**

- Q4 We would like to request Funktion VSport 710 as an equal for section 09 65 66 Resilient Athletic Flooring <https://calibersport.com/floors/vsport-710/>
- R4 **We do not have enough information to accept Funktion VSport 710 as an equal at this time.**
- Q5 Please provide grading plan that was properly printed to PDF from AutoCAD. Provided grading plan was scanned from original PDF. Scanned versions of the drawings restricts us to upload them to AutoCAD for grading calculations.
- R5 **Provided grading plan includes all information required to prepare a bid for this project.**
- Q6 A lot of the requirements for lighting are to be coordinated with the BAS. Please clarify who is the existing BAS vendor.
- R6 **BAS contractor is noted on drawing M3-1: Jake Rendulic at Siemens Canada Ltd. email: jake.rendulic@siemens.com**
- Q7 Can you please clarify and provide a line diagram of a sequence of action for the lighting relays.
It is unclear if the lighting controls are to be in a new relay panel beside the BAS or remote relays at the new panels. Please specify the relays needed. Who is the BAS supplier?
- R7 **Line diagram is not available. BAS contractor needs to provide a new point from their system for master control of lighting relays. A main relay to be provided that supplies line voltage power throughout the building to be used as the coil power for individual lighting circuit relays. Each of the individual lighting circuit relays are to be located above/near the local circuit panels**
- Q8 Drawing E2.3, detail 2, Ground Floor Key Plan, lists the Fire Alarm Control Panel as a Simplex 4007ES. During the site walk through I took a picture of the FACP, and it is a Autocall 4010.
We were just on a project with this exact same panel under the same circumstances. A simplex panel was listed as existing but had been recently changed to this Autocall system. We were told by the Simplex people that they can't work on these, and the programming and devices had to come from Hamilton Fire Control. Hamilton Fire Control then came in to take care of all the fire alarm verification and devices.
Please advise if we are still to carry Simplex in our bid package and not Hamilton Fire Control as the base building fire alarm contractor.

- R8** Hamilton Fire Control can be carried as the base building fire alarm contractor. The general contractor and their subtrades are to include the labour, material and equipment to complete the work outline in the drawings and specifications.
- Q9 Drawing A1.0 indicates to relocate shade structure and removal of existing 8 concrete pier and footing, as well as pouring new concrete footings where the shade is relocating. please provide structural detail for foundation of the shade structure that should be provided in the new location including the diameter and depth of pier as well as reinforcement requirements.
- R9** See enclosed detail 4/A1.0 added to Site Plan and Phasing Plan.
- Q10 Please clarify the extent of exterior concrete slab adjacent the ramp. Are we to remove and replace the slab up to the entrance door including forming and pouring of new steps or only up to the first step?
- R10** Replacement of all concrete slab at grade is in the scope. Existing landing at finish floor level and step are to remain.
- Q11 As this closing is on a Friday, Could the Tender closing date be moved to the following week, July 9, 10 or 11th?
- R11** Closing date remains unchanged.
- Q12 Will there be any Terrazzo repairs?
- R12** No terrazzo repairs anticipated.
- Q13 We require an extension on this closing. Due to a busy tender schedule, combined with absences, we will not be in a position to close this competitively, or otherwise. Please consider an extension to the following week.
- R13** Closing date remains unchanged.

End of Addendum #1



**GEOTECHNICAL INVESTIGATION AND
LIMITED CHEMICAL TESTING PROGRAM
ROSEDALE ELEMENTARY SCHOOL ADDITION
25 ERINDALE AVENUE
HAMILTON, ONTARIO
for
HAMILTON-WENTWORTH DISTRICT SCHOOL BOARD
c/o THIER + CURRAN ARCHITECTS INC.**

PETO MacCALLUM LTD.
45 BURFORD ROAD
HAMILTON, ONTARIO
L8E 3C6
Phone: (905) 561-2231
Fax: (905) 561-6366
Email: hamilton@petomaccallum.com

Distribution:
1 cc: Hamilton-Wentworth District School Board
3 cc: Thier + Curran Architects Inc.
1 cc: PML Hamilton

PML Ref.: 17HF044
Report: 2
February 2018

February 9, 2018

PML Ref.: 17HF044

Report: 2

Hamilton-Wentworth District School Board
c/o Mr. Stevan Gacesa
Thier + Curran Architects Inc.
118 James Street North, Suite 301
Hamilton, Ontario
L8R 2K7

Dear Mr. Gacesa

**Geotechnical Investigation and
Limited Chemical Testing Program
Rosedale Elementary School Addition
25 Erindale Avenue
Hamilton, Ontario**

Peto MacCallum Ltd. (PML) is pleased to present the results of the geotechnical investigation and limited chemical testing program recently completed for this project. Initial authorization to proceed with this assignment was provided by Stevan Gacesa of Thier + Curran Architects Incorporated in an email dated November 17, 2017. It is understood that since completion of the initial scope, the location of the proposed addition was revised. In this regard, a supplemental geotechnical investigation; as requested in an email dated December 18, 2017 was required. The scope of work for the supplemental investigation was provided in an email dated December 22, 2017; authorization was provided by Mr. Michael Lampietro of Hamilton-Wentworth District School Board (HWDSB) in an email dated January 8, 2018 and by HWDSB Purchase Order No. 7101803085 dated February 7, 2018.

It is understood that construction of a two storey gymnasium addition without a basement is planned at Rosedale Elementary School located at 25 Erindale Avenue in Hamilton, Ontario. Initial plans called for the addition to extend the existing gymnasium located on the south side of the school. Current plans call for building addition to cover a footprint of about 16 by 26 m located on the east side of the north wing of the school. It is understood the proposed finished floor slab elevation (FFE) will match the existing finished floor slab, near elevation 110.5.

The purpose of the geotechnical investigation was to assess the subsurface soil and ground water conditions at the site and based on the findings, provide geotechnical comments and recommendations for design and construction of the building addition.

A limited chemical testing program was included with the geotechnical work to check the geoenvironmental quality of the site soil in order to provide comments regarding on site or off site re-use and/or disposal options of excess soil.

The subsurface stratigraphy revealed in the boreholes typically comprised a pavement structure (asphalt over granular base) or topsoil fill over fill, overlying clay till.

Based on the findings of this investigation, it is considered feasible to construct the addition using standard construction practices.

The results of the limited chemical testing program indicate the chemical quality of the tested soil samples did not meet the site condition standards for Table 1 residential/parkland/institutional/industrial/commercial/community property use or Table 2 and Table 3 residential/parkland/institutional property use. The results met the site condition standards for Table 2 and Table 3 industrial/commercial/community property use. In this regard, off site re use will be subject to certain environmental handling restrictions.

Detailed comments and recommendations concerning the design and construction of the building addition as well as the results of the limited chemical testing program are provided in the attached report.

We trust the information presented in the attached report will be sufficient for your present purposes. If you have any questions, please do not hesitate to contact our office.

Sincerely

Peto MacCallum Ltd.

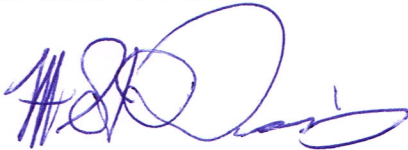
A handwritten signature in blue ink, appearing to read "M. St. Denis", with a stylized flourish at the end.

Matthew D. St. Denis, P.Eng.
Associate
Manager, Geotechnical Services

TF/KF:ld



TABLE OF CONTENTS

1. INTRODUCTION	1
2. INVESTIGATION PROCEDURES	2
3. SUMMARIZED SUBSURFACE CONDITIONS.....	3
3.1 Pavement Structure	3
3.2 Topsoil Fill.....	4
3.3 Fill.....	4
3.4 Clay Till	4
3.5 Ground Water Conditions	4
4. ENGINEERING DISCUSSION AND RECOMMENDATIONS	4
4.1 Foundations	5
4.1.1 Earthquake Considerations	6
4.2 Floor Slab Construction	6
4.3 Excavation	7
4.4 Ground Water Control.....	7
4.5 Re-use of Site Material	8
5. GEOENVIRONMENTAL CONSIDERATIONS.....	9
5.1.1 Chemical Testing Protocol.....	9
5.1.2 Site Condition Standards	10
5.1.3 Analytical Findings	12
5.1.3.1 On Site Re-Use	12
5.1.3.2 Off Site Re-Use	12
5.1.4 Discussion and Recommendations	13

List of Abbreviations

Log of Boreholes 2-1, 2-2, 2-101, and 2-102

Drawing 2-1 – Borehole Location Plan

Appendix A – Limited Chemical Testing Program

Table A1 – Soil Samples Submitted for Geoenvironmental Chemical Testing
SGS Canada Inc., Certificates of Analysis



1. INTRODUCTION

Peto MacCallum Ltd. (PML) is pleased to present the results of the geotechnical investigation and limited chemical testing program recently completed for this project. Initial authorization to proceed with this assignment was provided by Stevan Gacesa of Thier + Curran Architects Incorporated in an email dated November 17, 2017. Services were provided in accordance with PML's proposal, PML Ref.: FQH5844, dated November 3, 2017. It is understood that since completion of the initial scope, the location of the proposed addition was revised. In this regard, a supplemental geotechnical investigation; as requested in an email dated December 18, 2017 was required. The scope of work for the supplemental investigation was provided in an email dated December 22, 2017; authorization was provided by Mr. Michael Iampietro of Hamilton-Wentworth District School Board (HWDSB) in an email dated January 8, 2018 and by HWDSB Purchase Order No. 7101803085 dated February 7, 2018.

It is understood that construction of a two storey gymnasium addition without a basement is planned at Rosedale Elementary School located at 25 Erindale Avenue in Hamilton, Ontario. Initial plans called for the addition to extend the existing gymnasium located on the south side of the school. Current plans call for building addition to cover a footprint of about 16 by 26 m located on the east side of the north wing of the school. It is understood the proposed finished floor slab elevation (FFE) will match the existing finished floor slab, near elevation 110.5.

The purpose of the geotechnical investigation was to assess the subsurface soil and ground water conditions at the site and based on the findings, provide geotechnical comments and recommendations for design and construction of the building addition.

A limited chemical testing program was included with the geotechnical work to check the geoenvironmental quality of the site soil in order to provide comments regarding on site or off site re-use and/or disposal options of excess soil. It should be noted that ground water sampling and testing was not part of the Terms of Reference for this assignment and no work was carried out in this regard.



The comments and recommendations provided in this report are based on the site conditions at the time of the investigation and are applicable only to the proposed development as described in the report. Any changes in development, including finished grades and layout will require review by PML to assess the validity of the report and may require modified recommendations, additional investigation and/or analysis.

2. INVESTIGATION PROCEDURES

The initial field work was carried out on December 1, 2017 and consisted of two boreholes (Boreholes 2-1 and 2-2) drilled to 5.0 m termination depths. The supplemental field work was completed on January 5, 2018 and comprised two boreholes (Boreholes 2-101 and 2-102) drilled to 5.0 m termination depths. The borehole locations are shown on Drawing 2-1, appended.

The borehole locations were selected and established in the field by PML. Ground surface elevations and UTM co-ordinates at the borehole locations were determined by PML. The following benchmark was used for vertical reference:

BM: Tablet in south concrete foundation wall about 30.5 m north of edge of Dundonald Avenue, 61 cm from southeast corner, 30 cm below brick.
Elevation: 110.298 m (geodetic)

The boreholes were advanced using continuous flight solid stem augers, powered by track-mounted CME-55 and Diedrich D50 drill rigs, supplied and operated by specialist drilling contractors, working under the full time supervision of a member of PML's engineering staff.

Representative samples of the overburden were recovered at frequent depth intervals using a conventional split-spoon sampler during drilling. Standard penetration tests were conducted simultaneously with the sampling operation to assess the strength characteristics of the substrata. In situ pocket penetrometer tests were conducted on cohesive soils to determine in situ shear strength.

The ground water conditions at the borehole locations were assessed during drilling by visual examination of the soil, the sampler and the drill rods as the samples were retrieved and when appropriate by measurement of the water level in the open borehole.



Upon completion of drilling, the boreholes were decommissioned in accordance with O. Reg. 903/90, as amended.

The recovered samples were returned to our laboratory for detailed visual examination, classification and routine moisture content determinations.

Selected soil samples were submitted to SGS Canada Inc. for laboratory testing to assess the geoenvironmental properties of the soil. Details concerning the geoenvironmental chemical testing program including procedures and results of chemical testing are provided in Section 5.

3. SUMMARIZED SUBSURFACE CONDITIONS

Reference is made to the appended Log of Borehole sheets for details of the subsurface conditions including soil classifications, inferred stratigraphy, standard penetration test N values, pocket penetrometer shear strength values, ground water observations, and the results of laboratory moisture content determinations.

Due to the soil sampling procedures and limited sample size, the depth demarcations on the borehole logs must be viewed as transitional zones between layers and cannot be construed as exact geologic boundaries between layers. PML would be pleased to assist in defining geologic boundaries during construction if required.

The subsurface stratigraphy revealed in the boreholes typically comprised a pavement structure (asphalt over granular base) or topsoil fill over fill, overlying clay till.

3.1 Pavement Structure

A pavement structure comprising 60 and 75 mm of asphalt overlying 300 and 305 mm of sand and gravel granular base was encountered at the ground surface of Boreholes 2-101 and 2-102, respectively.



3.2 Topsoil Fill

In Boreholes 2-1 and 2-2, a 250 and 230 mm thick layer of topsoil fill was encountered surficially.

3.3 Fill

A 0.5 to 1.0 m thick layer of sandy silt or silty clay fill was encountered below the pavement structure and topsoil fill and was penetrated at depths of 0.8 to 1.4 m (elevation 108.4 to 109.7). The fill was loose/stiff and was judged to be moist/about plastic limit (APL) to wet/wetter than plastic limit (WTPL) with in situ moisture contents ranging from 18 to 21%.

3.4 Clay Till

Clay till was contacted below the fill at depths of 0.8 to 1.4 m (elevation 108.4 to 109.7) and was contacted to the termination depths of 5.0 m (elevation 104.7 to 105.5). The silty clay till was very stiff to hard and was judged to be drier than plastic limit (DTPL) to WTPL with a moisture content ranging from 16 to 19%.

3.5 Ground Water Conditions

Upon completion of augering, the boreholes were open and dry. Observed ground water levels may fluctuate subject to seasonal variations and precipitation patterns.

4. ENGINEERING DISCUSSION AND RECOMMENDATIONS

It is understood that construction of a two storey gymnasium addition without a basement is planned at Rosedale Elementary School located at 25 Erindale Avenue in Hamilton, Ontario. Initial plans called for the addition to extend the existing gymnasium located on the south side of the school. Current plans call for building addition to cover a footprint of about 16 by 26 m located on the east side of the north wing of the school. It is understood the proposed finished floor slab elevation (FFE) will match the existing finished floor slab, near elevation 110.5.



The subsurface stratigraphy revealed in the boreholes typically comprised a pavement structure (asphalt over granular base) or topsoil fill over fill, overlying clay till.

4.1 Foundations

Existing grade within the envelope of the proposed addition ranges from 109.7 to 109.8; the depth to competent native clay till is 1.1 and 1.4 m below the existing grade (elevation 108.6 and 108.4) in Boreholes 2-101 and 2-102, respectively.

Details concerning the proposed founding level for the structure were not provided. For the purposes of this report it is assumed that the footings will be founded at the usual depth of 1.5 m below the FFE near elevation 109.0.

Foundations at depth are considered suitable provided that the pavement structure, topsoil fill, and fill are subexcavated to the level of competent native soil (clay till). To reduce excavation, backfilling and structural concrete quantities, the foundation excavation may be partially backfilled with non-shrinkable fill to the underside of the footings. With the latter approach, the footings may be constructed at nominal depth as required for coverage.

Strip and spread footings founded on the native very stiff to hard clay till or on the non-shrinkable fill should be proportioned for a factored net bearing resistance at Ultimate Limit State (ULS) of 225 kPa and bearing resistance at Serviceability Limit State (SLS) of 150 kPa.

The new footings should be positioned at levels similar to the existing footings. Where founding levels of adjacent footings vary, the founding elevation between footings should be stepped in maximum 600 mm steps at a maximum inclination of 10 horizontal to 7 vertical (10H:7V). If adequate stepping of the footings is not possible due to site or design limitations, the need for underpinning of the existing foundations should be evaluated.

Prior to placement of structural concrete, all foundation excavations should be examined by geotechnical personnel from PML to verify that the founding stratum is in accordance with the assumptions and recommendations of this report. This will be particularly important near the



existing building, where the presence of fill material placed during construction of the existing structure may be present, which may require special treatment such as compaction or subexcavation and replacement with non-shrinkable fill.

All footings subject to frost action should be provided with the normal 1.2 m of earth cover or equivalent thermal insulation. A 25 mm thick layer of polystyrene insulation is thermally equivalent to 600 mm of soil cover.

The total settlement of foundations designed in accordance with the foregoing recommendations is not expected to exceed 25 mm. Differential settlement is expected to be less than 75% of this value.

All work should be carried out in accordance with the Occupational Health and Safety Act (Ontario Regulation 213/91) and with local regulations.

4.1.1 Earthquake Considerations

Design provisions for earthquake loading should also be applied. Based on the characteristics of the subsoils at this site, the subject property would be classified as Site Class C for footings bearing on native clay till per The Ontario Building Code Act, (2012) Section 4.1.8.4.

4.2 Floor Slab Construction

Construction of the floor slab as a conventional slab-on-grade on native clay till is considered to be feasible.

Preparation of the floor slab subgrade should include stripping of the pavement structure, topsoil fill, fill, and other deleterious material followed by proofrolling of the exposed subgrade with a heavy roller to ensure uniform adequate support. Excessively loose, soft or compressible materials revealed during the proofrolling operations should be subexcavated and replaced with well compacted approved material.

Fill placed under the floor slab to achieve finished subgrade levels or as foundation excavation backfill should comprise approved inorganic material having a moisture content within 3% of the



optimum value, placed in maximum 200 mm thick lifts, and compacted to at least 95% of standard Proctor maximum dry density (SPMDD).

A minimum 150 mm thick layer of well compacted free draining Granular A type material should be provided directly beneath the slab-on-grade. A polyethylene vapour barrier should be placed under the slab if a moisture sensitive finish is to be placed on the floor.

Exterior grades should be maintained at least 150 mm below the ground floor level and sloped to promote drainage away from the building.

4.3 Excavation

Excavation through the pavement structure, topsoil fill, and fill and into the clay till is expected to be relatively straight forward using conventional equipment. The possibility of debris in the fill and/or cobbles and boulders in the clay till should not be overlooked.

Provided adequate ground water control is achieved, the in-situ soil is classified as Type 3 soil according to the Occupational Health and Safety Act (OHSA) criteria. Therefore, excavation sidewalls should be cut at a maximum inclination of 1H:1V from the bottom of the excavation. It may be necessary to further flatten the trench side slopes if excessively loose/soft conditions or concentrated seepage zones are encountered locally.

All work should be carried out in accordance with the Occupational Health and Safety Act (Ontario Regulation 213/91) and with local regulations.

4.4 Ground Water Control

Upon completion of augering, the boreholes remained open and dry. Observed ground water levels may fluctuate subject to seasonal variations and precipitation patterns.

It is expected that seepage or surface water that enters the excavations will be adequately handled by conventional sump pumping techniques. The possibility of encountering concentrated



seepage from permeable layers within the fill and native soil requiring additional or high capacity pumps should not be overlooked.

It is recommended that construction be carried out during the dry summer months, when ground water levels are normally lowest to minimize the amount of ground water to be handled.

4.5 Re-use of Site Material

It is anticipated that the excavated material will generally consist of sandy silt or silty clay fill and native clay till.

Portions of the fill and native clay till are considered suitable for re-use as foundation and underfloor backfill, subject to evaluation at time of construction. Depending on seasonal conditions, some moisture content adjustments to the backfill materials may be required. The on-site soils are frost susceptible and are considered unsuitable for use where free draining backfill is required or at locations where frost related movement would present a concern.

It should be noted that the excavated till material will tend to retain a voided structure when placed as engineered fill, including foundation and trench backfill. It will be important to ensure that sufficient compaction effort is applied to thoroughly break down all lumps/clods within the backfill soil matrix to achieve a non voided condition. Significant post construction settlement could otherwise result. Excavated materials intended for backfilling purposes should not be exposed to the elements for prolonged time periods, as they might be rendered unsuitable for re-use.

In general, backfill should comprise inorganic, debris free material having a moisture content within 3% of the optimum value. Further, should construction extend into the winter season, particular attention must be given to ensure that frozen material is not used as backfill.

Organic soil, topsoil, deleterious or excessively wet material should not be used as backfill.



In areas that underlie floor slabs (i.e. interior foundation wall backfill), pavements and walkways, the foundation and service trench backfill should be compacted to at least 95% SPMDD. In landscaped areas, compaction to at least 90% SPMDD will be adequate.

Full time site observation should be carried out by PML to examine and approve backfill material, to carefully inspect placement operations, and to verify the compaction by in situ density testing using nuclear gauges.

5. GEOENVIRONMENTAL CONSIDERATIONS

PML understands that excess soil may be generated during construction; the volume of which is unknown at this time. A limited chemical testing program was carried out to check the geoenvironmental quality of the soil at selected sampling locations in order to provide comments regarding on site or off site re-use and/or disposal options of excess soil.

A Phase One Environmental Site Assessment (ESA) was not within the scope of work for this assignment. Accordingly, soil and ground water impairment that has not been identified by the limited chemical testing program may exist elsewhere at the site. The limited chemical testing program does not constitute an Environmental Site Assessment as defined under the Environmental Protection Act and O. Reg. 153/04, as amended.

5.1.1 Chemical Testing Protocol

Representative samples collected during the geotechnical investigation were returned to our laboratory for detailed visual examination. Soil samples were submitted for chemical analysis to SGS Canada Inc. (SGS), a Canadian Association for Laboratory Accreditation Inc. (CALA) accredited laboratory in Lakefield, Ontario. The chemical analyses conducted by SGS were in accordance with the O. Reg. 153/04, as amended Protocol for Analytical Methods Used in the Assessment of Properties under Part XV.1 of the Environmental Protection Act dated March 9, 2004, amended as of July 1, 2011.



As part of the geoenvironmental procedural protocol, all recovered soil samples were examined for visual and olfactory evidence of potential contamination.

Samples were reviewed and selected for chemical testing in accordance with the proposal whereby four soil samples (one per borehole) were selected and analyzed for general screening for metals and inorganic parameters.

The rationale for sample selection was based on materials exhibiting visual or olfactory evidence of contamination, material most likely to be contaminated (i.e. fill materials), site coverage and materials most likely to be excavated during construction.

A list of all samples submitted for analysis is included as Table A1, appended.

5.1.2 Site Condition Standards

The Ontario Ministry of the Environment and Climate Change (MOECC) has developed a set of Soil, Ground water and Sediment Standards for Use Under Part XV.1 of the Environmental Protection Act (April 15, 2011) and O. Reg. 153/04, as amended. The standards consist of nine tables (Table 1 through Table 9) that provide criteria for maximum concentrations of various contaminants. In general, the applicable O. Reg. 153/04, as amended Site Condition Standards (SCSs) depend on the site location, land use, soil texture, bedrock depth, soil pH and source of potable water at the investigation site.



In order to determine the Site Sensitivity, Sections 41 and 43.1 of O. Reg. 153/04, as amended were evaluated by PML as per the following table:

Site Condition Standard and Site Sensitivity Analysis

Criteria	Result
Current Property Use O. Reg. 153/04, as amended Part I Section 1	Institutional
Potable vs. Non-Potable Ground Water O. Reg. 153/04, as amended Part IX Section 35	Non-Potable
Proximity to Areas of Natural Significance O. Reg. 153/04, as amended Part IX Section 41 (1) (a)	>30 m
Soil pH O. Reg. 15/04, as amended Section 41 (1) b	Surface Soil: 5 to 9 Subsurface Soil: 5 to 11
Soil Texture O. Reg. 153/04, as amended Part IX Section 42	Coarse
Proximity to a Water Body O. Reg. 153/04, as amended Part IX Section 43.1	>30 m
Shallow Soil O. Reg. 153/04, as amended Part IX Section 43.1	No
Site Condition Standards	Table 3 (T3) Site Condition Standards (SCSs) for residential/parkland/institutional (RPI)

For the option of re-using the excess soils with minimal environmental restrictions, the O. Reg. 153/04, as amended, Full Depth Background T1 SCSs for residential/parkland/institutional/industrial/commercial/community (RPI/ICC) property uses were utilized.

For the option of re-using the excess soils at a property (or properties) with a potable ground water condition, the O. Reg. 153/04, as amended, Full Depth Generic Table 2 (T2) SCSs were utilized for both RPI and ICC land uses.



For the option of re-using the excess soils at a property (or properties) with a non potable ground water condition, the O. Reg. 153/04, as amended, Full Depth Generic Table 3 (T3) SCSs were utilized for both RPI and ICC land uses.

It is noted that a comparison to the Tables 4 and 5 SCSs for stratified site condition, Tables 6 and 7 SCSs for shallow bedrock condition and Table 8 and 9 for use within 30 m of a water body were not conducted as part of this assignment. If the potential receiving site for excess soil falls within one of these categories, additional evaluation by PML will be required to confirm conformance.

5.1.3 Analytical Findings

Laboratory Certificates of Analysis compared to T1 RPI/ICC and T3 ICC SCSs are included in Appendix A. The measured values and corresponding SCSs are shown on the certificates of analysis. In the event of an exceedance of the SCSs, the level is shown highlighted in orange, where applicable.

5.1.3.1 On Site Re-Use

Based on the results of chemical testing the measured concentration of the tested parameters complied with the T3 RPI SCSs with the exception of Electrical Conductivity (EC) in Borehole 2-102 (Sample BH2-102 SS2).

5.1.3.2 Off Site Re-Use

A comparison of the results was carried out against the more common SCSs of T1, T2 and T3. The following table outlines a summary of the suitability for re-use of excess soil material based on the limited chemical testing.

Table 1 (RPI/ICC)	Table 2 (RPI)	Table 2 (ICC)	Table 3 (RPI)	Table 3 (ICC)	Licensed Landfill
No	No	Yes	No	Yes	TCLP Testing would be required

Note: TCLP - Toxicity Characteristic Leaching Procedure



5.1.4 Discussion and Recommendations

If the excess soil is to be removed from the site for off site re-use, the following conditions must be met:

- The work must be completed in accordance with local by-laws governing soil movement and/or placement at other sites;
- All analytical results and environmental assessment reports must be fully disclosed to the receiving site owners/authorities and they have agreed to receive the material;
- The applicable SCSs for the receiving site have been determined, as confirmed by the environmental consultant and the SCSs are consistent with the chemical quality of the soil originating at the source site;
- Transportation and placement of the excess soil is monitored by the environmental consultant to check the material is appropriately placed at the pre-approved site;
- The receiving site must be arranged and/or approved well in advance of excavation in order to avoid delays during construction. As well, it is noted the chemical testing requirements for various receiving sites is site-specific and additional testing may be required, beyond that provided in this report.
- The excavation work should be conducted in accordance with a written Soil Management Plan prepared by a qualified professional to ensure that all excess excavated material is tested and managed appropriately, and that imported fill material is of suitable quality and meets the SCSs applicable to the site. Re-use of excess excavated soil on site is also subject to acceptance for re-use by the geotechnical consultant at the time of construction based on geotechnical considerations.

It is recommended that transportation of fill material from the Source Site(s) to the Receiving Site(s) be carried out in accordance with the MOECC document Management of Excess Soil – A Guide for Best Management Practices dated January 2014.

Elevated levels of EC were detected in one sample of fill in Borehole 2-102. In this regard, delineation and segregation of the EC impacted soil may allow for additional off site re-use options for excess soil.



It is recommended that additional sampling and chemical testing be conducted during construction to verify the chemical quality of the excess soil to assess the appropriate management/disposal options for the soil leaving the site.

It should be noted that the soil conditions between and beyond the sampled locations may differ from those encountered during this assignment. PML should be contacted if impacted soil conditions become apparent during future development to further assess and appropriately handle the materials, if any, and evaluate whether modifications to the conclusions documented in this report are necessary.

There is no legal requirement to remove or treat the soil that exceeds the SCSs applicable to the site provided it is demonstrated that there is no on site or off site impact/contaminant migration or adverse effect. However, if contaminated soil is left on site, the landowner assumes liability associated with the contamination. The liability concerns could include potential scrutiny from the MOECC, neighbouring property owners and the public, potential for decreased value of the land and issues during potential divesting of the property due to environmental liability concerns on the part of future owners or their financiers/insurers.

We trust the information presented in this report is sufficient for your present purposes. If you have any questions, please do not hesitate to contact our office.

Sincerely

Peto MacCallum Ltd.



Timothy Feather, B.Eng., EIT
Project Supervisor



Karel Furbacher, P.Eng.
Project Engineer



Matthew D. St. Denis, P.Eng.
Associate
Manager, Geotechnical Services

TF/KF:ld

LIST OF ABBREVIATIONS



PENETRATION RESISTANCE

Standard Penetration Resistance N: - The number of blows required to advance a standard split spoon sampler 0.3 m into the subsoil. Driven by means of a 63.5 kg hammer falling freely a distance of 0.76 m.

Dynamic Penetration Resistance: - The number of blows required to advance a 51 mm, 60 degree cone, fitted to the end of drill rods, 0.3 m into the subsoil. The driving energy being 475 J per blow.

DESCRIPTION OF SOIL

The consistency of cohesive soils and the relative density or denseness of cohesionless soils are described in the following terms:

<u>CONSISTENCY</u>	<u>N (blows/0.3 m)</u>	<u>c (kPa)</u>	<u>DENSENESS</u>	<u>N (blows/0.3 m)</u>
Very Soft	0 - 2	0 - 12	Very Loose	0 - 4
Soft	2 - 4	12 - 25	Loose	4 - 10
Firm	4 - 8	25 - 50	Compact	10 - 30
Stiff	8 - 15	50 - 100	Dense	30 - 50
Very Stiff	15 - 30	100 - 200	Very Dense	> 50
Hard	> 30	> 200		
WTPL	Wetter Than Plastic Limit			
APL	About Plastic Limit			
DTPL	Drier Than Plastic Limit			

TYPE OF SAMPLE

SS	Split Spoon	TW	Thinwall Open
WS	Washed Sample	TP	Thinwall Piston
SB	Scraper Bucket Sample	OS	Oesterberg Sample
AS	Auger Sample	FS	Foil Sample
CS	Chunk Sample	RC	Rock Core
ST	Slotted Tube Sample		
	PH	Sample Advanced Hydraulically	
	PM	Sample Advanced Manually	

SOIL TESTS

Qu	Unconfined Compression	LV	Laboratory Vane
Q	Undrained Triaxial	FV	Field Vane
Qcu	Consolidated Undrained Triaxial	C	Consolidation
Qd	Drained Triaxial		

LOG OF BOREHOLE NO. 2-2

17T 596814E 4786390N

PROJECT Rosedale Elementary School Addition
LOCATION 25 Erindale Avenue, Hamilton
BORING METHOD Continuous Flight Solid Stem Augers

BORING DATE December 1, 2017

PML REF. 17HF044
ENGINEER M. D. St. Denis
TECHNICIAN K. Pettitt

SOIL PROFILE			SAMPLES			ELEVATION SCALE	SHEAR STRENGTH (kPa)		PLASTIC LIMIT	NATURAL MOISTURE CONTENT	LIQUID LIMIT	UNIT WEIGHT	GROUND WATER OBSERVATIONS AND REMARKS
DEPTH ELEV (metres)	DESCRIPTION	STRAT PLOT	NUMBER	TYPE	"N" VALUES		+ FIELD VANE	Δ TORVANE					
0.0	SURFACE ELEVATION 110.38												
0.23	TOPSOIL FILL: 230 mm, dark brown sandy silt topsoil fill, trace clay, moist; occasional rootlets	[Diagonal Hatching]	1A										
110.15			1B	SS	6								
0.75	FILL: Loose, brown sandy silt fill, some clay, moist	[Diagonal Hatching]	2'	SS	17								
109.63			3	SS	25								
2.1	CLAY TILL: Very stiff, brown silty clay till, some sand, trace gravel, DTPL; with bluish grey fissures, occasional shale fragments	[Diagonal Hatching]	4	SS	40								
108.3			5	SS	37								
4.0	becoming hard	[Diagonal Hatching]	6	SS	17								
106.4													
5.0	becoming very stiff, grey, trace sand, WTPL	[Diagonal Hatching]											
105.4													
5.0	BOREHOLE TERMINATED AT 5.0 m												Upon completion of augering, no free water, no cave

NOTES 1. Sample submitted for chemical testing

LOG OF BOREHOLE NO. 2-101

17T 596823E 4786460N

PROJECT Rosedale Elementary School Addition
LOCATION 25 Erindale Avenue, Hamilton
BORING METHOD Continuous Flight Solid Stem Augers

BORING DATE January 5, 2018

PML REF. 17HF044
ENGINEER M. D. St. Denis
TECHNICIAN K. Pettitt

SOIL PROFILE			SAMPLES			SHEAR STRENGTH (kPa)		PLASTIC NATURAL LIQUID			UNIT WEIGHT	GROUND WATER OBSERVATIONS AND REMARKS		
DEPTH ELEV (metres)	DESCRIPTION	STRAT PLOT	NUMBER	TYPE	"N" VALUES	+ FIELD VANE Δ TORVANE ○ Qu				LIMIT			MOISTURE CONTENT	LIMIT
						▲ POCKET PENETROMETER ○ Q								
						DYNAMIC CONE PENETRATION × STANDARD PENETRATION TEST ●				WATER CONTENT (%)				
						50 100 150 200				w _p w w _L				
						20 40 60 80				10 20 30 40				
						kN/m ³				GR SA SI CL				
0.0	SURFACE ELEVATION 109.67													
0.36	PAVEMENT STRUCTURE: 60 mm asphalt over 300 mm brown sand and gravel granular base	[Symbol]	1	AS										
109.31														
1.1	CLAY TILL: Very stiff to hard, brown silty clay till, some sand, trace gravel, DTPL; with bluish grey fissures, occasional shale fragments,	[Symbol]	2A	SS	9									
108.6			2B											
			3'	SS	27									
2.0			4	SS	36									
3.0			5	SS	39									
4.0			6	SS	36									
5.0	BOREHOLE TERMINATED AT 5.0 m												Upon completion of augering, no free water, no cave	
104.7														
6.0														
7.0														
8.0														
9.0														
10.0														
11.0														
12.0														
13.0														
14.0														
15.0														

NOTES 1. Sample submitted for chemical testing

LOG OF BOREHOLE NO. 2-102

17T 596817E 4786439N

PROJECT Rosedale Elementary School Addition
LOCATION 25 Erindale Avenue, Hamilton
BORING METHOD Continuous Flight Solid Stem Augers

BORING DATE January 5, 2018

PML REF. 17HF044
ENGINEER M. D. St. Denis
TECHNICIAN K. Pettitt

SOIL PROFILE			SAMPLES			SHEAR STRENGTH (kPa)		PLASTIC NATURAL LIQUID			UNIT WEIGHT	GROUND WATER OBSERVATIONS AND REMARKS		
DEPTH ELEV (metres)	DESCRIPTION	STRAT PLOT	NUMBER	TYPE	"N" VALUES	+ FIELD VANE Δ TORVANE ○ Qu				LIMIT			MOISTURE CONTENT	LIMIT
						▲ POCKET PENETROMETER ○ Q								
						DYNAMIC CONE PENETRATION × STANDARD PENETRATION TEST ●				WATER CONTENT (%)				
						50 100 150 200				w _p w w _L				
						20 40 60 80				10 20 30 40				
						kN/m ³				GR SA SI CL				
0.0	SURFACE ELEVATION 109.80													
0.38	PAVEMENT STRUCTURE: 75 mm asphalt over 305 mm brown sand and gravel granular base		1	AS										
109.42	FILL: Stiff, grey silty clay fill, some sand, trace gravel, APL TO WTPL		2'	SS	8									
1.4	CLAY TILL: Very stiff to hard, brown silty clay till, some sand, trace gravel, DTPL; with bluish grey fissures, occasional shale fragments,		3	SS	26									
108.4			4	SS	30									
2.0			5	SS	35									
3.0														
4.0														
5.0	BOREHOLE TERMINATED AT 5.0 m		6	SS	26									
104.8													Upon completion of augering, no free water, no cave	

NOTES 1. Sample submitted for chemical testing

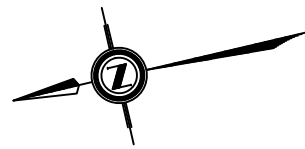

ABERFOYLE AVENUE

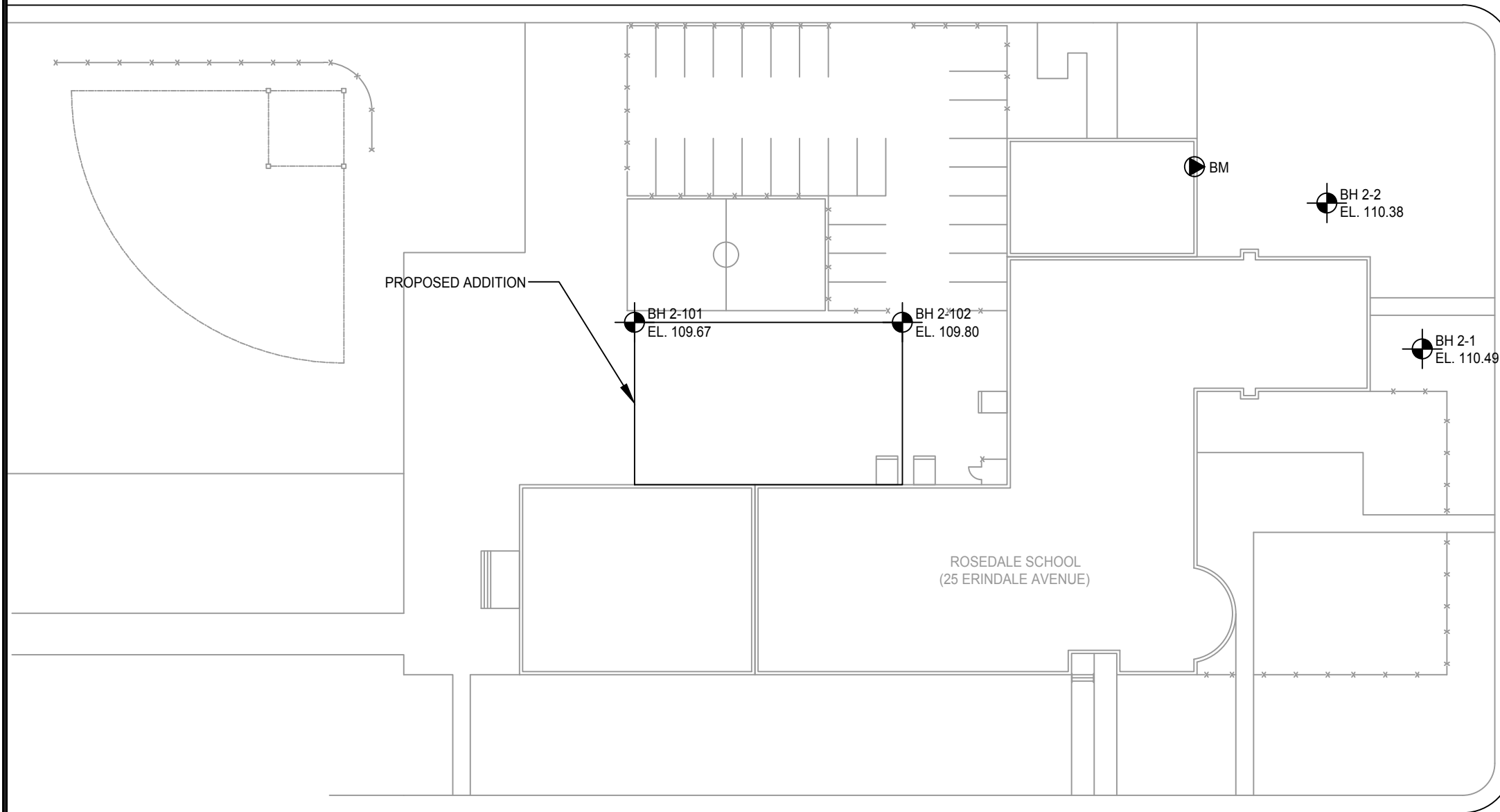

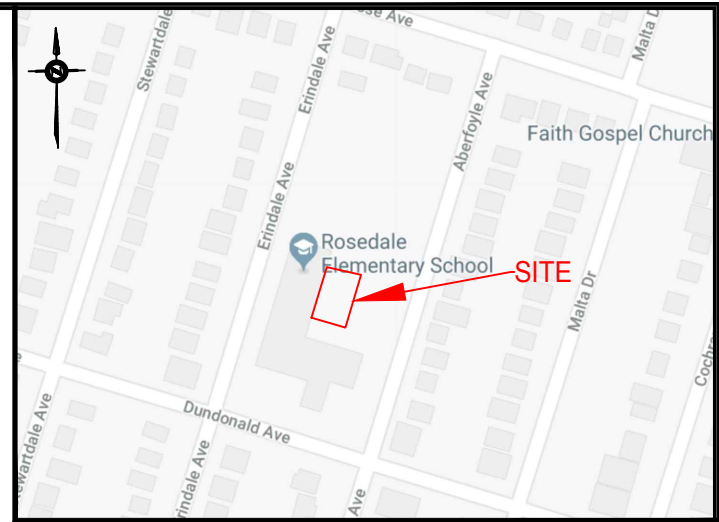

ROSEDALE SCHOOL
(25 ERINDALE AVENUE)

ERINDALE AVENUE



KEY PLAN
HAMILTON, ONTARIO

LEGEND:

-  BH 2-102
EL. 109.80 PML BOREHOLE (BH) LOCATION
-  BENCHMARK (BM)

BENCHMARK:

TABLET IN SOUTH CONCRETE FOUNDATION WALL ABOUT 30.5 M NORTH OF EDGE OF DUNDONALD AVENUE, 61 CM FROM SOUTHEAST CORNER, 30 CM BELOW BRICK.
ELEVATION: 110.298 m (GEODETIC)

REFERENCE:

PLAN PRODUCED FROM A DRAWING TITLED "ADDITION/RENOVATION TO HWDSB ROSEDALE ELEMENTARY SCHOOL" BY THIER+CURRAN ARCHITECTS INC., DATED DECEMBER 8, 2017.

NOTE:

THE INFERRED STRATIGRAPHY REFERRED TO IN THE REPORT IS BASED ON THE DATA FROM THESE BOREHOLES SUPPLEMENTED BY GEOLOGICAL EVIDENCE. THE ACTUAL STRATIGRAPHY BETWEEN THE BOREHOLES MAY VARY.

DUNDONALD AVENUE

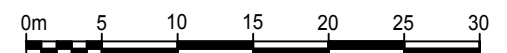

SCALE
(1:500)

HWDSB					
GEOTECHNICAL INVESTIGATION AND LIMITED CHEMICAL TESTING PROGRAM ROSEDALE SCHOOL ADDITION 25 ERINDALE AVENUE, HAMILTON					
BOREHOLE LOCATION PLAN					
 Peto MacCallum Ltd. CONSULTING ENGINEERS					
<small>DRAWN</small>	<small>KP/TF</small>	<small>DATE</small>	<small>SCALE</small>	<small>PML REF.</small>	<small>DRAWING NO.</small>
<small>CHECKED</small>	<small>KF</small>	JAN. 2018	AS SHOWN	17HF044	2-1
<small>APPROVED</small>	<small>MDS</small>				



Appendix A

Limited Chemical Testing Program

Table A1 – Soil Samples Submitted for Geoenvironmental Chemical Testing

SGS Canada Inc. – Certificates of Analysis



TABLE A1

Summary of Samples Submitted for Geoenvironmental Chemical Testing

Location	Sample ID	Approx. Depth (m)	Description
Borehole 2-1	BH2-1 SS1B	0.3 – 0.8	Fill
Borehole 2-2	BH2-2 SS2	0.8 – 1.2	Clay Till
Borehole 2-101	BH2-101 SS3	1.5 – 2.0	Clay Till
Borehole 2-102	BH2-102 SS2	0.8 – 1.2	Fill

Note: All samples submitted for O. Reg. 153/04, as amended metals and inorganics package chemical testing.



FINAL REPORT

CA14054-DEC17 R

17HF044

Prepared for

Peto MacCallum Ltd

First Page

CLIENT DETAILS		LABORATORY DETAILS	
Client	Peto MacCallum Ltd	Project Specialist	Deanna Edwards, B.Sc, C.Chem
Address	45 Burford Road Hamilton, ON L8E 3C6.	Laboratory	SGS Canada Inc.
Contact	Timothy Feather	Address	185 Concession St., Lakefield ON, K0L 2H0
Telephone	(905) 561-2231	Telephone	705-652-2000
Facsimile	(905) 561-6366	Facsimile	705-652-6365
Email	tfeather@petomacallum.com	Email	deanna.edwards@sgs.com
Project	17HF044	SGS Reference	CA14054-DEC17
Order Number		Received	12/04/2017
Samples	Soil (2)	Approved	12/07/2017
		Report Number	CA14054-DEC17 R
		Date Reported	12/07/2017

COMMENTS

Temperature of Sample upon Receipt: 8 degrees C
 Cooling Agent Present: Yes
 Custody Seal Present: No

SIGNATORIES

Deanna Edwards, B.Sc, C.Chem



TABLE OF CONTENTS

First Page.....	1
Index.....	2
Results.....	3-5
Exceedance Summary.....	6
QC Summary.....	7-11
Legend.....	12
Annexes.....	13-14



FINAL REPORT

CA14054-DEC17 R

Client: Peto MacCallum Ltd

Project: 17HF044

Project Manager: Timothy Feather

Samplers: Kurtis P

PACKAGE: REG153 - 1.2.2 Metals (SOIL)

Sample Number	10	11
Sample Name	BH2-1 SS1B	BH2-2 SS2
Sample Matrix	Soil	Soil
Sample Date	01/12/2017	01/12/2017

L1 = REG153 / SOIL / COARSE - TABLE 1 - Residential/Parkland/Industrial - UNDEFINED

L2 = REG153 / SOIL / COARSE - TABLE 3 - Industrial/Commercial - UNDEFINED

Parameter	Units	RL	L1	L2	Result	Result
1.2.2 Metals						
Barium	µg/g	0.01	220	670	63	120
Beryllium	µg/g	0.02	2.5	8	0.72	0.85
Boron	µg/g	1	36	120	4	7
Cadmium	µg/g	0.02	1.2	1.9	0.14	0.09
Chromium	µg/g	0.5	70	160	19	22
Cobalt	µg/g	0.01	21	80	9.5	12
Copper	µg/g	0.1	92	230	22	29
Lead	µg/g	0.1	120	120	17	12
Molybdenum	µg/g	0.1	2	40	0.4	0.3
Nickel	µg/g	0.1	82	270	19	28
Silver	µg/g	0.01	0.5	40	0.43	< 0.01
Thallium	µg/g	0.02	1	3.3	0.11	0.14
Uranium	µg/g	0.002	2.5	33	0.46	0.51
Vanadium	µg/g	3	86	86	28	31
Zinc	µg/g	0.7	290	340	64	63

PACKAGE: REG153 - 1.2.3 Hydrides (SOIL)

Sample Number	10	11
Sample Name	BH2-1 SS1B	BH2-2 SS2
Sample Matrix	Soil	Soil
Sample Date	01/12/2017	01/12/2017

L1 = REG153 / SOIL / COARSE - TABLE 1 - Residential/Parkland/Industrial - UNDEFINED

L2 = REG153 / SOIL / COARSE - TABLE 3 - Industrial/Commercial - UNDEFINED

Parameter	Units	RL	L1	L2	Result	Result
1.2.3 Hydrides						
Antimony	µg/g	0.8	1.3	40	< 0.8	< 0.8



FINAL REPORT

CA14054-DEC17 R

Client: Peto MacCallum Ltd

Project: 17HF044

Project Manager: Timothy Feather

Samplers: Kurtis P

PACKAGE: REG153 - 1.2.3 Hydrides (SOIL)

Sample Number	10	11
Sample Name	BH2-1 SS1B	BH2-2 SS2
Sample Matrix	Soil	Soil
Sample Date	01/12/2017	01/12/2017

L1 = REG153 / SOIL / COARSE - TABLE 1 - Residential/Parkland/Industrial - UNDEFINED

L2 = REG153 / SOIL / COARSE - TABLE 3 - Industrial/Commercial - UNDEFINED

Parameter	Units	RL	L1	L2	Result	Result
-----------	-------	----	----	----	--------	--------

1.2.3 Hydrides (continued)

Arsenic	µg/g	0.5	18	18	3.6	4.3
Selenium	µg/g	0.7	1.5	5.5	< 0.7	< 0.7

PACKAGE: REG153 - 1.3 Other (ORP) (SOIL)

Sample Number	10	11
Sample Name	BH2-1 SS1B	BH2-2 SS2
Sample Matrix	Soil	Soil
Sample Date	01/12/2017	01/12/2017

L1 = REG153 / SOIL / COARSE - TABLE 1 - Residential/Parkland/Industrial - UNDEFINED

L2 = REG153 / SOIL / COARSE - TABLE 3 - Industrial/Commercial - UNDEFINED

Parameter	Units	RL	L1	L2	Result	Result
-----------	-------	----	----	----	--------	--------

1.3 Other (ORP)

Mercury	µg/g	0.05	0.27	3.9	< 0.05	< 0.05
Water Soluble Boron	µg/g	0.5		2	< 0.5	< 0.5
Sodium Adsorption Ratio	---	0.2	2.4	12	0.8	0.5
Conductivity	mS/cm	0.002	0.57	1.4	0.45	0.27
pH	no unit	0.05			7.48	7.50
Chromium VI	µg/g	0.2	0.66	8	0.6	0.4
Free Cyanide	µg/g	0.05	0.051	0.051	< 0.05	< 0.05

PACKAGE: REG153 - UNDEFINED (SOIL)

Sample Number	10	11
Sample Name	BH2-1 SS1B	BH2-2 SS2
Sample Matrix	Soil	Soil
Sample Date	01/12/2017	01/12/2017

L1 = REG153 / SOIL / COARSE - TABLE 1 - Residential/Parkland/Industrial - UNDEFINED

L2 = REG153 / SOIL / COARSE - TABLE 3 - Industrial/Commercial - UNDEFINED

Parameter	Units	RL	L1	L2	Result	Result
-----------	-------	----	----	----	--------	--------

UNDEFINED



FINAL REPORT

CA14054-DEC17 R

Client: Peto MacCallum Ltd

Project: 17HF044

Project Manager: Timothy Feather

Samplers: Kurtis P

PACKAGE: **REG153 - UNDEFINED (SOIL)**

L1 = REG153 / SOIL / COARSE - TABLE 1 - Residential/Parkland/Industrial - UNDEFINED

L2 = REG153 / SOIL / COARSE - TABLE 3 - Industrial/Commercial - UNDEFINED

Sample Number	10	11
Sample Name	BH2-1 SS1B	BH2-2 SS2
Sample Matrix	Soil	Soil
Sample Date	01/12/2017	01/12/2017

Parameter	Units	RL	L1	L2	Result	Result
UNDEFINED (continued)						
Moisture Content	%	-			20.4	16.0

EXCEEDANCE SUMMARY

No exceedances are present above the regulatory limit(s) indicated



FINAL REPORT

CA14054-DEC17 R

QC SUMMARY

Conductivity

Method: EPA 6010/SM 2510 | Internal ref.: ME-CA-IENVIEWL-LAK-AN-006

Parameter	QC batch Reference	Units	RL	Method Blank	Duplicate		LCS/Spike Blank			Matrix Spike / Ref.		
					RPD	AC (%)	Spike Recovery (%)	Recovery Limits (%)		Spike Recovery (%)	Recovery Limits (%)	
								Low	High		Low	High
Conductivity	EWL0083-DEC17	mS/cm	0.002	<0.002	0	10	99	90	110	NA		

Cyanide by SFA

Method: SM 4500 | Internal ref.: ME-CA-IENVISFA-LAK-AN-005

Parameter	QC batch Reference	Units	RL	Method Blank	Duplicate		LCS/Spike Blank			Matrix Spike / Ref.		
					RPD	AC (%)	Spike Recovery (%)	Recovery Limits (%)		Spike Recovery (%)	Recovery Limits (%)	
								Low	High		Low	High
Free Cyanide	SKA5005-DEC17	µg/g	0.05	<0.05	ND	20	102	80	120	84	75	125

Hexavalent Chromium by IC

Method: EPA218.6/EPA3060A | Internal ref.: ME-CA-IENVIIC-LAK-AN-008

Parameter	QC batch Reference	Units	RL	Method Blank	Duplicate		LCS/Spike Blank			Matrix Spike / Ref.		
					RPD	AC (%)	Spike Recovery (%)	Recovery Limits (%)		Spike Recovery (%)	Recovery Limits (%)	
								Low	High		Low	High
Chromium VI	DIO0054-DEC17	µg/g	0.2	<0.2	ND	20	111	80	120	99	75	125

QC SUMMARY

Mercury by CVAAS

Method: EPA 7471A/EPA 245 | Internal ref.: ME-CA-IENVISPE-LAK-AN-004

Parameter	QC batch Reference	Units	RL	Method Blank	Duplicate		LCS/Spike Blank			Matrix Spike / Ref.		
					RPD	AC (%)	Spike Recovery (%)	Recovery Limits (%)		Spike Recovery (%)	Recovery Limits (%)	
								Low	High		Low	High
Mercury	EHG0006-DEC17	µg/g	0.05	<0.05	ND	20	99	80	120	91	70	130

Metals in aqueous samples - ICP-OES

Method: MOE 4696e01/EPA 6010 | Internal ref.: ME-CA-IENVISPE-LAK-AN-003

Parameter	QC batch Reference	Units	RL	Method Blank	Duplicate		LCS/Spike Blank			Matrix Spike / Ref.		
					RPD	AC (%)	Spike Recovery (%)	Recovery Limits (%)		Spike Recovery (%)	Recovery Limits (%)	
								Low	High		Low	High
SAR Calcium	ESG0020-DEC17	mg/L	0.09	<0.09	ND	20	99	80	120	93	70	130
SAR Magnesium	ESG0020-DEC17	mg/L	0.02	<0.02	ND	20	93	80	120	94	70	130
SAR Sodium	ESG0020-DEC17	mg/L	0.15	<0.15	ND	20	96	80	120	94	70	130

QC SUMMARY

Metals in Soil - Aqua-regia/ICP-MS

Method: EPA 3050/EPA 200.8 | Internal ref.: ME-CA-IENVISPE-LAK-AN-005

Parameter	QC batch Reference	Units	RL	Method Blank	Duplicate		LCS/Spike Blank			Matrix Spike / Ref.		
					RPD	AC (%)	Spike Recovery (%)	Recovery Limits (%)		Spike Recovery (%)	Recovery Limits (%)	
								Low	High		Low	High
Silver	EMS0015-DEC17	µg/g	0.01	<0.01	ND	20	106	70	130	102	70	130
Arsenic	EMS0015-DEC17	µg/g	0.5	<0.5	5	20	100	70	130	104	70	130
Barium	EMS0015-DEC17	µg/g	0.01	<0.01	8	20	103	70	130	94	70	130
Beryllium	EMS0015-DEC17	µg/g	0.02	<0.02	4	20	106	70	130	107	70	130
Boron	EMS0015-DEC17	µg/g	1	<1	1	20	104	70	130	101	70	130
Cadmium	EMS0015-DEC17	µg/g	0.02	<0.02	10	20	106	70	130	104	70	130
Cobalt	EMS0015-DEC17	µg/g	0.01	<0.01	6	20	103	70	130	111	70	130
Chromium	EMS0015-DEC17	µg/g	0.5	<0.5	6	20	100	70	130	109	70	130
Copper	EMS0015-DEC17	µg/g	0.1	<0.1	3	20	108	70	130	107	70	130
Molybdenum	EMS0015-DEC17	µg/g	0.1	<0.1	16	20	96	70	130	109	70	130
Nickel	EMS0015-DEC17	µg/g	0.1	<0.1	6	20	102	70	130	110	70	130
Lead	EMS0015-DEC17	µg/g	0.1	<0.1	3	20	97	70	130	103	70	130
Antimony	EMS0015-DEC17	µg/g	0.8	<0.8	ND	20	95	70	130	117	70	130
Selenium	EMS0015-DEC17	µg/g	0.7	<0.7	ND	20	96	70	130	95	70	130
Thallium	EMS0015-DEC17	µg/g	0.02	<0.02	ND	20	96	70	130	103	70	130
Uranium	EMS0015-DEC17	µg/g	0.002	<0.002	10	20	93	70	130	90	70	130
Vanadium	EMS0015-DEC17	µg/g	3	<3	7	20	107	70	130	110	70	130
Zinc	EMS0015-DEC17	µg/g	0.7	<0.7	5	20	108	70	130	104	70	130

QC SUMMARY

pH

Method: SM 4500 | Internal ref.: ME-CA-IENVIEWL-LAK-AN-001

Parameter	QC batch Reference	Units	RL	Method Blank	Duplicate		LCS/Spike Blank			Matrix Spike / Ref.		
					RPD	AC (%)	Spike Recovery (%)	Recovery Limits (%)		Spike Recovery (%)	Recovery Limits (%)	
								Low	High		Low	High
pH	ARD0020-DEC17	no unit	0.05		0	20	101	80	120			

Sodium adsorption ratio (SAR)

Method: MOE 4696e01/EPA 6010 | Internal ref.: ME-CA-IENVIARD-LAK-AN-021

Parameter	QC batch Reference	Units	RL	Method Blank	Duplicate		LCS/Spike Blank			Matrix Spike / Ref.		
					RPD	AC (%)	Spike Recovery (%)	Recovery Limits (%)		Spike Recovery (%)	Recovery Limits (%)	
								Low	High		Low	High
Sodium Adsorption Ratio	ESG0020-DEC17	---	0.2	< 0.09	ND	20	99	80	120	93	70 130	

Water Soluble Boron

Method: O.Req. 153/04 | Internal ref.: ME-CA-IENVI SPE-LAK-AN-003

Parameter	QC batch Reference	Units	RL	Method Blank	Duplicate		LCS/Spike Blank			Matrix Spike / Ref.		
					RPD	AC (%)	Spike Recovery (%)	Recovery Limits (%)		Spike Recovery (%)	Recovery Limits (%)	
								Low	High		Low	High
Water Soluble Boron	ESG0014-DEC17	µg/g	0.5	<0.5	ND	20	100	80	120	113	70 130	

QC SUMMARY

Method Blank: a blank matrix that is carried through the entire analytical procedure. Used to assess laboratory contamination.

Duplicate: Paired analysis of a separate portion of the same sample that is carried through the entire analytical procedure. Used to evaluate measurement precision.

LCS/Spike Blank: Laboratory control sample or spike blank refer to a blank matrix to which a known amount of analyte has been added. Used to evaluate analyte recovery and laboratory accuracy without sample matrix effects.

Matrix Spike: A sample to which a known amount of the analyte of interest has been added. Used to evaluate laboratory accuracy with sample matrix effects.

Reference Material: a material or substance matrix matched to the samples that contains a known amount of the analyte of interest. A reference material may be used in place of a matrix spike.

RL: Reporting limit

RPD: Relative percent difference

AC: Acceptance criteria

Multielement Scan Qualifier: as the number of analytes in a scan increases, so does the chance of a limit exceedance by random chance as opposed to a real method problem. Thus, in multielement scans, for the LCS and matrix spike, up to 10% of the analytes may exceed the quoted limits by up to 10% absolute and the spike is considered acceptable.

Duplicate Qualifier: for duplicates as the measured result approaches the RL, the uncertainty associated with the value increases dramatically, thus duplicate acceptance limits apply only where the average of the two duplicates is greater than five times the RL.

Matrix Spike Qualifier: for matrix spikes, as the concentration of the native analyte increases, the uncertainty of the matrix spike recovery increases. Thus, the matrix spike acceptance limits apply only when the concentration of the matrix spike is greater than or equal to the concentration of the native analyte.

LEGEND

FOOTNOTES

NSS Insufficient sample for analysis.
RL Reporting Limit.
 ↑ Reporting limit raised.
 ↓ Reporting limit lowered.
NA The sample was not analysed for this analyte
ND Non Detect

Samples analysed as received. Solid samples expressed on a dry weight basis. "Temperature Upon Receipt" is representative of the whole shipment and may not reflect the temperature of individual samples.

SGS provides criteria information (such as regulatory or guideline limits and summary of limit exceedances) as a service. Every attempt is made to ensure the criteria information in this report is accurate and current, however, it is not guaranteed. Comparison to the most current criteria is the responsibility of the client and SGS assumes no responsibility for the accuracy of the criteria levels indicated. This document is issued, on the Client's behalf, by the Company under its General Conditions of Service available on request and accessible at http://www.sgs.com/terms_and_conditions.htm. The Client's attention is drawn to the limitation of liability, indemnification and jurisdiction issues defined therein. Any other holder of this document is advised that information contained hereon reflects the Company's findings at the time of its intervention only and within the limits of Client's instructions, if any. The Company's sole responsibility is to its Client and this document does not exonerate parties to a transaction from exercising all their rights and obligations under the transaction documents.

This report must not be reproduced, except in full. This report supersedes all previous versions.

-- End of Analytical Report --



SGS Environment,
Health and Safety

Request for Laboratory Services and CHAIN OF CUSTODY

- Lakefield: 185 Concession St., Lakefield, ON K0L 2H0 Phone: 705-652-2000 Toll Free: 877-747-7658 Fax: 705-652-6365
- London: 657 Consortium Court, London, ON, N6E 2S8 Phone: 519-672-4500 Toll Free: 877-848-8060 Fax: 519-672-0361 Web: www.ca.sgs.com

No: _____
Page 1 of 1

Laboratory Information Section - Lab use only

Received By: TRICK ADJE
Received Date: 12/01/17 (mm/dd/yy)
Received Time: 11:25 (am) (pm) (circle)

Received By (signature): _____
Custody Seal Present: Y / X (circle)
Custody Seal Intact: Y / N (circle)

Cooling Agent Present: Y / N Type: ICE LAB LIMS #: CAM654-Dee F
Temperature Upon Receipt (°C): 7-877-98.0 8x3 BM

REPORT INFORMATION
Company: Petromallium
Contact: Tim Feather
Address: 45 Bw York Rd. Hamilton
Phone: 405-561-2231
Fax: 405-561-0300
Email: tfeather@petromallium.com

INVOICE INFORMATION
 (same as Report Information)
Company: _____
Contact: _____
Address: _____
Phone: _____
Email: _____

PROJECT INFORMATION
Quotation #: _____ P.O. #: _____
Project #: 174F044 Site Location/ID: _____
TURNAROUND TIME (TAT) REQUIRED
 Regular TAT (5-7days) TAT's are quoted in business days (exclude statutory holidays & weekends).
Samples received after 3pm or on weekends : TAT begins the next business day
RUSH TAT (Additional Charges May Apply) 1 Day 2 Days 3-4 Days
PLEASE CONFIRM RUSH FEASIBILITY WITH SGS REPRESENTATIVE PRIOR TO SUBMISSION
Specify Due Date: _____ Rush Confirmation ID: _____

REGULATIONS
Regulation 153 (2011):
 Table RP1/74 Res/Park Soil Texture: _____
 Table 2 Ind/Com Coarse
 Table 3-7U Agri/Other Medium
 Table _____ Fine
Other Regulations:
 Reg 347/558 (3 Day min TAT)
 PWQO MMER
 CCME Other:
 MISA
Sewer By-Law:
 Sanitary
 Storm
Municipality: _____

DRINKING WATER SAMPLES (POTABLE WATER FOR HUMAN CONSUMPTION) MUST BE SUBMITTED WITH SGS DRINKING WATER CHAIN OF CUSTODY

RECORD OF SITE CONDITION (RSC) YES NO

ANALYSIS REQUESTED										COMMENTS: Field Filtered (F) Preserved (P)
Metals and Trace Elements										
X										
X										

SAMPLE IDENTIFICATION	DATE SAMPLED	TIME SAMPLED	# OF BOTTLES	MATRIX
1 BH2-1 551B	12/01/17	Am	1	5051
2 BH2-2 552	12/01/17	11	1	11
3				
4				
5				
6				
7				
8				
9				
10				

Observations/Comments/Special Instructions

Sampled By (NAME): Kwadiis Peltit Signature: KP Date: 12/01/17 (mm/dd/yy) Pink Copy - Client
Relinquished by (NAME): Tim Feather Signature: TF Date: 12/04/17 (mm/dd/yy) Yellow & White Copy - SGS



SAMPLE INTEGRITY REPORT

Project Number: 174FO44
 SGS Sample ID CA14054-Dec17
 Date / Time Sampled Dec 1/17
 Client Sample ID See CoC

ONTARIO REGULATION 153/04

ALL
 Sample Submission General Sample Integrity Violations

- Temperature >10 C upon receipt if not sampled same day
- No evidence of cooling trend initiated if sampled same day
- Chain of Custody not submitted
- Chain of Custody incomplete
- Chain of Custody not signed / dated
- Chain of Custody not a current version
- Bottles / Samples listed on CoC but not received
- Bottles / Samples received but not listed on the CoC
- Sample container received empty

Sample Specific Sample Integrity Violations

Sample received past hold time	<input type="checkbox"/>	<input type="checkbox"/>	<input type="checkbox"/>	<input type="checkbox"/>	<input type="checkbox"/>	<input type="checkbox"/>	<input type="checkbox"/>
Incorrect preservation (including no preservation where required)	<input type="checkbox"/>	<input type="checkbox"/>	<input type="checkbox"/>	<input type="checkbox"/>	<input type="checkbox"/>	<input type="checkbox"/>	<input type="checkbox"/>
Headspace present in VOC vial (aqueous)	<input type="checkbox"/>	<input type="checkbox"/>	<input type="checkbox"/>	<input type="checkbox"/>	<input type="checkbox"/>	<input type="checkbox"/>	<input type="checkbox"/>
Sample(s) received frozen	<input type="checkbox"/>	<input type="checkbox"/>	<input type="checkbox"/>	<input type="checkbox"/>	<input type="checkbox"/>	<input type="checkbox"/>	<input type="checkbox"/>
Bottle(s) broken or damaged in transport	<input type="checkbox"/>	<input type="checkbox"/>	<input type="checkbox"/>	<input type="checkbox"/>	<input type="checkbox"/>	<input type="checkbox"/>	<input type="checkbox"/>
Discrepancy between sample label and chain of custody	<input type="checkbox"/>	<input type="checkbox"/>	<input type="checkbox"/>	<input type="checkbox"/>	<input type="checkbox"/>	<input type="checkbox"/>	<input type="checkbox"/>
Analysis requirements absent / unclear	<input type="checkbox"/>	<input type="checkbox"/>	<input type="checkbox"/>	<input type="checkbox"/>	<input type="checkbox"/>	<input type="checkbox"/>	<input type="checkbox"/>
Missing or incorrect sample label(s)	<input type="checkbox"/>	<input type="checkbox"/>	<input type="checkbox"/>	<input type="checkbox"/>	<input type="checkbox"/>	<input type="checkbox"/>	<input type="checkbox"/>
Inappropriate sample container used	<input type="checkbox"/>	<input type="checkbox"/>	<input type="checkbox"/>	<input type="checkbox"/>	<input type="checkbox"/>	<input type="checkbox"/>	<input type="checkbox"/>
Insufficient number of bottles received	<input type="checkbox"/>	<input type="checkbox"/>	<input type="checkbox"/>	<input type="checkbox"/>	<input type="checkbox"/>	<input type="checkbox"/>	<input type="checkbox"/>
Limited sample volume	<input type="checkbox"/>	<input type="checkbox"/>	<input type="checkbox"/>	<input type="checkbox"/>	<input type="checkbox"/>	<input type="checkbox"/>	<input type="checkbox"/>
Insufficient sample volume	<input type="checkbox"/>	<input type="checkbox"/>	<input type="checkbox"/>	<input type="checkbox"/>	<input type="checkbox"/>	<input type="checkbox"/>	<input type="checkbox"/>
Sample contains multiple phases	<input type="checkbox"/>	<input type="checkbox"/>	<input type="checkbox"/>	<input type="checkbox"/>	<input type="checkbox"/>	<input type="checkbox"/>	<input type="checkbox"/>

Sediment Log

Groundwater samples contain visible sediment / particulate	<input type="checkbox"/>	<input type="checkbox"/>	<input type="checkbox"/>	<input type="checkbox"/>	<input type="checkbox"/>	<input type="checkbox"/>	<input type="checkbox"/>
Groundwater contains greater than 1cm of sediment / particulate matter in bottle	<input type="checkbox"/>	<input type="checkbox"/>	<input type="checkbox"/>	<input type="checkbox"/>	<input type="checkbox"/>	<input type="checkbox"/>	<input type="checkbox"/>

Additional Comments/Remarks:

No issues upon receipt



Initials:

BM



FINAL REPORT

CA14141-JAN18 R

17HF044

Prepared for

Peto MacCallum Ltd

First Page

CLIENT DETAILS

LABORATORY DETAILS

Client	Peto MacCallum Ltd	Project Specialist	Deanna Edwards, B.Sc, C.Chem
Address	45 Burford Road Hamilton, ON L8E 3C6.	Laboratory	SGS Canada Inc.
Contact	Timothy Feather	Address	185 Concession St., Lakefield ON, K0L 2H0
Telephone	(905) 561-2231	Telephone	705-652-2000
Facsimile	(905) 561-6366	Facsimile	705-652-6365
Email	tfeather@petomacallum.com	Email	deanna.edwards@sgs.com
Project	17HF044	SGS Reference	CA14141-JAN18
Order Number		Received	01/09/2018
Samples	Soil (2)	Approved	01/12/2018
		Report Number	CA14141-JAN18 R
		Date Reported	01/12/2018

COMMENTS

Temperature of Sample upon Receipt 4 degrees C
 Cooling Agent Present
 Custody Seal Not Present

Chain of Custody Number 00545

SIGNATORIES

Deanna Edwards, B.Sc, C.Chem



TABLE OF CONTENTS

First Page.....	1
Index.....	2
Results.....	3-5
Exceedance Summary.....	6
QC Summary.....	7-11
Legend.....	12
Annexes.....	13-14



FINAL REPORT

CA14141-JAN18 R

Client: Peto MacCallum Ltd

Project: 17HF044

Project Manager: Timothy Feather

Samplers: K B

PACKAGE: REG153 - 1.2.2 Metals (SOIL)

Sample Number	10	11
Sample Name	BH2-101 SS3	BH2-102 SS2
Sample Matrix	Soil	Soil
Sample Date	05/01/2018	05/01/2018

L1 = REG153 / SOIL / COARSE - TABLE 1 - Residential/Parkland/Industrial - UNDEFINED

L2 = REG153 / SOIL / COARSE - TABLE 3 - Industrial/Commercial - UNDEFINED

Parameter	Units	RL	L1	L2	Result	Result
1.2.2 Metals						
Barium	µg/g	0.01	220	670	120	89
Beryllium	µg/g	0.02	2.5	8	0.66	0.62
Boron	µg/g	1	36	120	8	5
Cadmium	µg/g	0.02	1.2	1.9	0.09	0.14
Chromium	µg/g	0.5	70	160	21	21
Cobalt	µg/g	0.01	21	80	11	11
Copper	µg/g	0.1	92	230	27	32
Lead	µg/g	0.1	120	120	14	15
Molybdenum	µg/g	0.1	2	40	0.4	0.4
Nickel	µg/g	0.1	82	270	26	26
Silver	µg/g	0.01	0.5	40	0.02	0.03
Thallium	µg/g	0.02	1	3.3	0.18	0.17
Uranium	µg/g	0.002	2.5	33	0.62	0.45
Vanadium	µg/g	3	86	86	33	34
Zinc	µg/g	0.7	290	340	60	77



FINAL REPORT

CA14141-JAN18 R

Client: Peto MacCallum Ltd

Project: 17HF044

Project Manager: Timothy Feather

Samplers: K B

PACKAGE: REG153 - 1.2.3 Hydrides (SOIL)

Sample Number	10	11
Sample Name	BH2-101 SS3	BH2-102 SS2
Sample Matrix	Soil	Soil
Sample Date	05/01/2018	05/01/2018

L1 = REG153 / SOIL / COARSE - TABLE 1 - Residential/Parkland/Industrial - UNDEFINED

L2 = REG153 / SOIL / COARSE - TABLE 3 - Industrial/Commercial - UNDEFINED

Parameter	Units	RL	L1	L2	Result	Result
-----------	-------	----	----	----	--------	--------

1.2.3 Hydrides

Antimony	µg/g	0.8	1.3	40	< 0.8	< 0.8
Arsenic	µg/g	0.5	18	18	4.2	4.9
Selenium	µg/g	0.7	1.5	5.5	< 0.7	< 0.7

PACKAGE: REG153 - 1.3 Other (ORP) (SOIL)

Sample Number	10	11
Sample Name	BH2-101 SS3	BH2-102 SS2
Sample Matrix	Soil	Soil
Sample Date	05/01/2018	05/01/2018

L1 = REG153 / SOIL / COARSE - TABLE 1 - Residential/Parkland/Industrial - UNDEFINED

L2 = REG153 / SOIL / COARSE - TABLE 3 - Industrial/Commercial - UNDEFINED

Parameter	Units	RL	L1	L2	Result	Result
-----------	-------	----	----	----	--------	--------

1.3 Other (ORP)

Mercury	µg/g	0.05	0.27	3.9	< 0.05	< 0.05
Water Soluble Boron	µg/g	0.5		2	< 0.5	< 0.5
Sodium Adsorption Ratio	---	0.2	2.4	12	0.3	3.6
Conductivity	mS/cm	0.002	0.57	1.4	0.18	0.78
pH	no unit	0.05			7.78	7.34
Chromium VI	µg/g	0.2	0.66	8	0.2	< 0.2
Free Cyanide	µg/g	0.05	0.051	0.051	< 0.05	< 0.05



FINAL REPORT

CA14141-JAN18 R

Client: Peto MacCallum Ltd

Project: 17HF044

Project Manager: Timothy Feather

Samplers: K B

PACKAGE: **REG153 - UNDEFINED (SOIL)**

Sample Number	10	11
Sample Name	BH2-101 SS3	BH2-102 SS2
Sample Matrix	Soil	Soil
Sample Date	05/01/2018	05/01/2018

L1 = REG153 / SOIL / COARSE - TABLE 1 - Residential/Parkland/Industrial - UNDEFINED

L2 = REG153 / SOIL / COARSE - TABLE 3 - Industrial/Commercial - UNDEFINED

Parameter	Units	RL	L1	L2	Result	Result
UNDEFINED						
Moisture Content	%	-			15.3	17.6

EXCEEDANCE SUMMARY

Parameter	Method	Units	Result	REG153 / SOIL / COARSE - TABLE 1 - Residential/Parkland/Industrial - UNDEFINED L1	REG153 / SOIL / COARSE - TABLE 3 - Industrial/Commercial - UNDEFINED L2
-----------	--------	-------	--------	--	--

BH2-102 SS2

Conductivity	EPA 6010/SM 2510	mS/cm	0.78	0.57
Sodium Adsorption Ratio	MOE 4696e01/EPA 6010	---	3.6	2.4



FINAL REPORT

CA14141-JAN18 R

QC SUMMARY

Conductivity

Method: EPA 6010/SM 2510 | Internal ref.: ME-CA-IENVIEWL-LAK-AN-006

Parameter	QC batch Reference	Units	RL	Method Blank	Duplicate		LCS/Spike Blank			Matrix Spike / Ref.		
					RPD	AC (%)	Spike Recovery (%)	Recovery Limits (%)		Spike Recovery (%)	Recovery Limits (%)	
								Low	High		Low	High
Conductivity	EWL0125-JAN18	mS/cm	0.002	<0.002	0	10	99	90	110	NA		

Cyanide by SFA

Method: SM 4500 | Internal ref.: ME-CA-IENVISFA-LAK-AN-005

Parameter	QC batch Reference	Units	RL	Method Blank	Duplicate		LCS/Spike Blank			Matrix Spike / Ref.		
					RPD	AC (%)	Spike Recovery (%)	Recovery Limits (%)		Spike Recovery (%)	Recovery Limits (%)	
								Low	High		Low	High
Free Cyanide	SKA5018-JAN18	µg/g	0.05	<0.05	ND	20	101	80	120	117	75	125

Hexavalent Chromium by IC

Method: EPA218.6/EPA3060A | Internal ref.: ME-CA-IENVIIC-LAK-AN-008

Parameter	QC batch Reference	Units	RL	Method Blank	Duplicate		LCS/Spike Blank			Matrix Spike / Ref.		
					RPD	AC (%)	Spike Recovery (%)	Recovery Limits (%)		Spike Recovery (%)	Recovery Limits (%)	
								Low	High		Low	High
Chromium VI	DIO0123-JAN18	µg/g	0.2	<0.2	37	20	102	80	120	84	75	125



FINAL REPORT

CA14141-JAN18 R

QC SUMMARY

Mercury by CVAAS

Method: EPA 7471A/EPA 245 | Internal ref.: ME-CA-IENVISPE-LAK-AN-004

Parameter	QC batch Reference	Units	RL	Method Blank	Duplicate		LCS/Spike Blank			Matrix Spike / Ref.		
					RPD	AC (%)	Spike Recovery (%)	Recovery Limits (%)		Spike Recovery (%)	Recovery Limits (%)	
								Low	High		Low	High
Mercury	EHG0014-JAN18	µg/g	0.05	<0.05	ND	20	101	80	120	90	70	130

Metals in aqueous samples - ICP-OES

Method: MOE 4696e01/EPA 6010 | Internal ref.: ME-CA-IENVISPE-LAK-AN-003

Parameter	QC batch Reference	Units	RL	Method Blank	Duplicate		LCS/Spike Blank			Matrix Spike / Ref.		
					RPD	AC (%)	Spike Recovery (%)	Recovery Limits (%)		Spike Recovery (%)	Recovery Limits (%)	
								Low	High		Low	High
SAR Calcium	ESG0029-JAN18	mg/L	0.09	<0.09	2	20	101	80	120	101	70	130
SAR Magnesium	ESG0029-JAN18	mg/L	0.02	<0.02	1	20	96	80	120	104	70	130
SAR Sodium	ESG0029-JAN18	mg/L	0.15	<0.15	2	20	93	80	120	105	70	130

QC SUMMARY

Metals in Soil - Aqua-regia/ICP-MS

Method: EPA 3050/EPA 200.8 | Internal ref.: ME-CA-IENVISPE-LAK-AN-005

Parameter	QC batch Reference	Units	RL	Method Blank	Duplicate		LCS/Spike Blank			Matrix Spike / Ref.		
					RPD	AC (%)	Spike Recovery (%)	Recovery Limits (%)		Spike Recovery (%)	Recovery Limits (%)	
								Low	High		Low	High
Silver	EMS0042-JAN18	µg/g	0.01	<0.01	ND	20	105	70	130	94	70	130
Arsenic	EMS0042-JAN18	µg/g	0.5	<0.5	2	20	104	70	130	106	70	130
Barium	EMS0042-JAN18	µg/g	0.01	<0.01	5	20	106	70	130	92	70	130
Beryllium	EMS0042-JAN18	µg/g	0.02	<0.02	3	20	98	70	130	88	70	130
Boron	EMS0042-JAN18	µg/g	1	<1	2	20	103	70	130	92	70	130
Cadmium	EMS0042-JAN18	µg/g	0.02	<0.02	8	20	108	70	130	97	70	130
Cobalt	EMS0042-JAN18	µg/g	0.01	<0.01	3	20	101	70	130	99	70	130
Chromium	EMS0042-JAN18	µg/g	0.5	<0.5	2	20	100	70	130	93	70	130
Copper	EMS0042-JAN18	µg/g	0.1	<0.1	2	20	103	70	130	100	70	130
Molybdenum	EMS0042-JAN18	µg/g	0.1	<0.1	5	20	100	70	130	97	70	130
Nickel	EMS0042-JAN18	µg/g	0.1	<0.1	4	20	105	70	130	98	70	130
Lead	EMS0042-JAN18	µg/g	0.1	<0.1	0	20	101	70	130	96	70	130
Antimony	EMS0042-JAN18	µg/g	0.8	<0.8	ND	20	93	70	130	115	70	130
Selenium	EMS0042-JAN18	µg/g	0.7	<0.7	ND	20	107	70	130	102	70	130
Thallium	EMS0042-JAN18	µg/g	0.02	<0.02	2	20	101	70	130	105	70	130
Uranium	EMS0042-JAN18	µg/g	0.002	<0.002	2	20	97	70	130	85	70	130
Vanadium	EMS0042-JAN18	µg/g	3	<3	2	20	105	70	130	104	70	130
Zinc	EMS0042-JAN18	µg/g	0.7	<0.7	0	20	105	70	130	98	70	130



FINAL REPORT

CA14141-JAN18 R

QC SUMMARY

pH

Method: SM 4500 | Internal ref.: ME-CA-IENVIEWL-LAK-AN-001

Parameter	QC batch Reference	Units	RL	Method Blank	Duplicate		LCS/Spike Blank			Matrix Spike / Ref.		
					RPD	AC (%)	Spike Recovery (%)	Recovery Limits (%)		Spike Recovery (%)	Recovery Limits (%)	
								Low	High		Low	High
pH	ARD0035-JAN18	no unit	0.05		0	20	101	80	120			

Water Soluble Boron

Method: O.Reg. 153/04 | Internal ref.: ME-CA-IENVI SPE-LAK-AN-003

Parameter	QC batch Reference	Units	RL	Method Blank	Duplicate		LCS/Spike Blank			Matrix Spike / Ref.		
					RPD	AC (%)	Spike Recovery (%)	Recovery Limits (%)		Spike Recovery (%)	Recovery Limits (%)	
								Low	High		Low	High
Water Soluble Boron	ESG0022-JAN18	µg/g	0.5	<0.5	ND	20	99	80	120	115	70 130	

QC SUMMARY

Method Blank: a blank matrix that is carried through the entire analytical procedure. Used to assess laboratory contamination.

Duplicate: Paired analysis of a separate portion of the same sample that is carried through the entire analytical procedure. Used to evaluate measurement precision.

LCS/Spike Blank: Laboratory control sample or spike blank refer to a blank matrix to which a known amount of analyte has been added. Used to evaluate analyte recovery and laboratory accuracy without sample matrix effects.

Matrix Spike: A sample to which a known amount of the analyte of interest has been added. Used to evaluate laboratory accuracy with sample matrix effects.

Reference Material: a material or substance matrix matched to the samples that contains a known amount of the analyte of interest. A reference material may be used in place of a matrix spike.

RL: Reporting limit

RPD: Relative percent difference

AC: Acceptance criteria

Multielement Scan Qualifier: as the number of analytes in a scan increases, so does the chance of a limit exceedance by random chance as opposed to a real method problem. Thus, in multielement scans, for the LCS and matrix spike, up to 10% of the analytes may exceed the quoted limits by up to 10% absolute and the spike is considered acceptable.

Duplicate Qualifier: for duplicates as the measured result approaches the RL, the uncertainty associated with the value increases dramatically, thus duplicate acceptance limits apply only where the average of the two duplicates is greater than five times the RL.

Matrix Spike Qualifier: for matrix spikes, as the concentration of the native analyte increases, the uncertainty of the matrix spike recovery increases. Thus, the matrix spike acceptance limits apply only when the concentration of the matrix spike is greater than or equal to the concentration of the native analyte.

LEGEND

FOOTNOTES

NSS Insufficient sample for analysis.
RL Reporting Limit.
 ↑ Reporting limit raised.
 ↓ Reporting limit lowered.
NA The sample was not analysed for this analyte
ND Non Detect

Samples analysed as received. Solid samples expressed on a dry weight basis. "Temperature Upon Receipt" is representative of the whole shipment and may not reflect the temperature of individual samples.

SGS provides criteria information (such as regulatory or guideline limits and summary of limit exceedances) as a service. Every attempt is made to ensure the criteria information in this report is accurate and current, however, it is not guaranteed. Comparison to the most current criteria is the responsibility of the client and SGS assumes no responsibility for the accuracy of the criteria levels indicated. This document is issued, on the Client's behalf, by the Company under its General Conditions of Service available on request and accessible at http://www.sgs.com/terms_and_conditions.htm. The Client's attention is drawn to the limitation of liability, indemnification and jurisdiction issues defined therein. Any other holder of this document is advised that information contained hereon reflects the Company's findings at the time of its intervention only and within the limits of Client's instructions, if any. The Company's sole responsibility is to its Client and this document does not exonerate parties to a transaction from exercising all their rights and obligations under the transaction documents.

This report must not be reproduced, except in full. This report supersedes all previous versions.

-- End of Analytical Report --



SGS Environment, Health and Safety

Request for Laboratory Services and CHAIN OF CUSTODY

- Lakefield: 185 Concession St., Lakefield, ON K0L 2H0 Phone: 705-652-2000 Toll Free: 877-747-7658 Fax: 705-652-6365
- London: 657 Consortium Court, London, ON, N6E 2S8 Phone: 519-672-4500 Toll Free: 877-848-8060 Fax: 519-672-0361 Web: www.ca.sgs.com

No: 00545
Page 1 of 1

Laboratory Information Section - Lab use only

Received By: [Signature]
Received Date: 01/09/18
Received Time: 12:38 am

Received By (signature): [Signature]
Custody Seal Present: Y/N (circle)
Custody Seal Intact: Y/N (circle)

Cooling Agent Present: Y/N Type: ICE
Temperature Upon Receipt (°C): 5.56-6.67
LAB LIMS #: CA141-Jan 18

REPORT INFORMATION
Company: Petomacallum
Contact: Tim Feather
Address: 45 Burford Rd. Hamilton
Phone: 905-561-2231
Fax: 905-561-6366
Email: tfeather@Petomacallum.com

INVOICE INFORMATION
[same as Report Information]
Company:
Contact:
Address:
Phone:
Email:

PROJECT INFORMATION
Quotation #:
P.O. #:
Project #: 174E044
Site Location/ID:

TURNAROUND TIME (TAT) REQUIRED
Regular TAT (5-7days)
RUSH TAT (Additional Charges May Apply)
PLEASE CONFIRM RUSH FEASIBILITY WITH SGS REPRESENTATIVE PRIOR TO SUBMISSION

REGULATIONS
Regulation 153 (2011):
Other Regulations:
Sewer By-Law:
Municipality:

DRINKING WATER SAMPLES (POTABLE WATER FOR HUMAN CONSUMPTION) MUST BE SUBMITTED WITH SGS DRINKING WATER CHAIN OF CUSTODY

ANALYSIS REQUESTED table with columns for various parameters

COMMENTS: Field Filtered (F) Preserved (P)

RECORD OF SITE CONDITION (RSC) YES NO

Table with columns: SAMPLE IDENTIFICATION, DATE SAMPLED, TIME SAMPLED, # OF BOTTLES, MATRIX

Vertical handwritten note: 519-672-4500

Observations/Comments/Special Instructions

Sampled By (NAME): [Signature] Signature: [Signature] Date: 01/05/18
Relinquished by (NAME): Tim Feather Signature: [Signature] Date: 01/09/18



SAMPLE INTEGRITY REPORT

Project Number: 17HF044

ONTARIO REGULATION 153/04

SGS Sample ID CA14141-Jan18

Date / Time Sampled Jan 5/18

Client Sample ID See CoFC

ALL

Sample Submission General Sample Integrity Violations

- Temperature >10 C upon receipt if not sampled same day
- No evidence of cooling trend initiated if sampled same day
- Chain of Custody not submitted
- Chain of Custody incomplete
- Chain of Custody not signed / dated
- Chain of Custody not a current version
- Bottles / Samples listed on CoC but not received
- Bottles / Samples received but not listed on the CoC
- Sample container received empty

Sample Specific Sample Integrity Violations

Sample received past hold time	<input type="checkbox"/>	<input type="checkbox"/>	<input type="checkbox"/>	<input type="checkbox"/>	<input type="checkbox"/>	<input type="checkbox"/>	<input type="checkbox"/>
Incorrect preservation (including no preservation where required)	<input type="checkbox"/>	<input type="checkbox"/>	<input type="checkbox"/>	<input type="checkbox"/>	<input type="checkbox"/>	<input type="checkbox"/>	<input type="checkbox"/>
Headspace present in VOC vial (aqueous)	<input type="checkbox"/>	<input type="checkbox"/>	<input type="checkbox"/>	<input type="checkbox"/>	<input type="checkbox"/>	<input type="checkbox"/>	<input type="checkbox"/>
Sample(s) received frozen	<input type="checkbox"/>	<input type="checkbox"/>	<input type="checkbox"/>	<input type="checkbox"/>	<input type="checkbox"/>	<input type="checkbox"/>	<input type="checkbox"/>
Bottle(s) broken or damaged in transport	<input type="checkbox"/>	<input type="checkbox"/>	<input type="checkbox"/>	<input type="checkbox"/>	<input type="checkbox"/>	<input type="checkbox"/>	<input type="checkbox"/>
Discrepancy between sample label and chain of custody	<input type="checkbox"/>	<input type="checkbox"/>	<input type="checkbox"/>	<input type="checkbox"/>	<input type="checkbox"/>	<input type="checkbox"/>	<input type="checkbox"/>
Analysis requirements absent / unclear	<input type="checkbox"/>	<input type="checkbox"/>	<input type="checkbox"/>	<input type="checkbox"/>	<input type="checkbox"/>	<input type="checkbox"/>	<input type="checkbox"/>
Missing or incorrect sample label(s)	<input type="checkbox"/>	<input type="checkbox"/>	<input type="checkbox"/>	<input type="checkbox"/>	<input type="checkbox"/>	<input type="checkbox"/>	<input type="checkbox"/>
Inappropriate sample container used	<input type="checkbox"/>	<input type="checkbox"/>	<input type="checkbox"/>	<input type="checkbox"/>	<input type="checkbox"/>	<input type="checkbox"/>	<input type="checkbox"/>
Insufficient number of bottles received	<input type="checkbox"/>	<input type="checkbox"/>	<input type="checkbox"/>	<input type="checkbox"/>	<input type="checkbox"/>	<input type="checkbox"/>	<input type="checkbox"/>
Limited sample volume	<input type="checkbox"/>	<input type="checkbox"/>	<input type="checkbox"/>	<input type="checkbox"/>	<input type="checkbox"/>	<input type="checkbox"/>	<input type="checkbox"/>
Insufficient sample volume	<input type="checkbox"/>	<input type="checkbox"/>	<input type="checkbox"/>	<input type="checkbox"/>	<input type="checkbox"/>	<input type="checkbox"/>	<input type="checkbox"/>
Sample contains multiple phases	<input type="checkbox"/>	<input type="checkbox"/>	<input type="checkbox"/>	<input type="checkbox"/>	<input type="checkbox"/>	<input type="checkbox"/>	<input type="checkbox"/>

Sediment Log

- Groundwater samples contain visible sediment / particulate
- Groundwater contains greater than 1cm of sediment / particulate matter in bottle

Additional Comments/Remarks:

No issues upon receipt



Initials:

[Handwritten initials]

LEGEND OF EXISTING FEATURES

- SITE BOUNDARY
- EXISTING SPOT ELEVATIONS/CONTOURS
- EXISTING DIRECTION OF DRAINAGE/SWALE
- EXISTING ARMOUR STONE
- EXISTING BUILDING
- EXISTING FENCE
- EXISTING RETAINING WALL

LEGEND OF PROPOSED FEATURES

- REMOVALS
- SEDIMENT CONTROL FENCE (SEE DETAIL ON C2.2)
- SILT SACK (SEE DETAIL ON C2.2)
- CONSTRUCTION ACCESS (SEE DETAIL ON C2.2)
- OVERLAND FLOW ROUTE (MAJOR STORM)
- SAW CUT c/w LAP JOINT (SEE DETAIL ON C2.2)

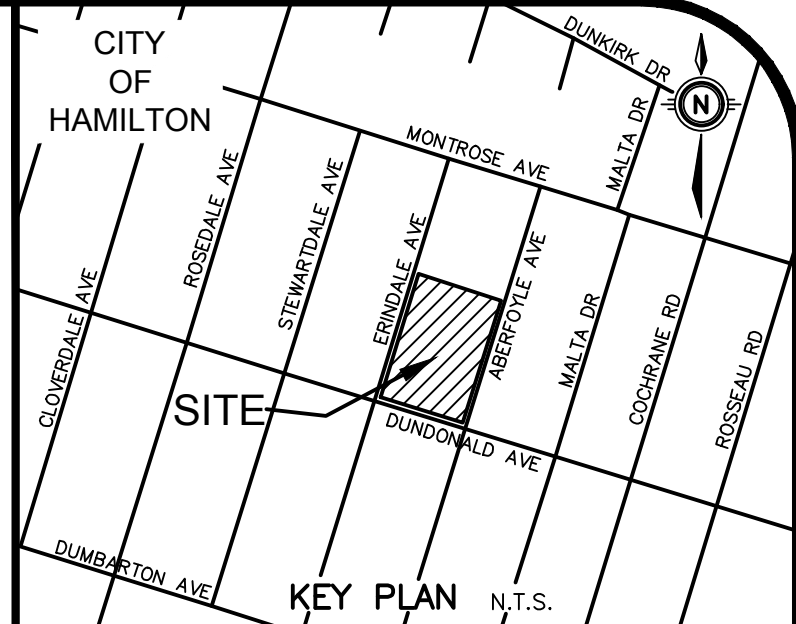
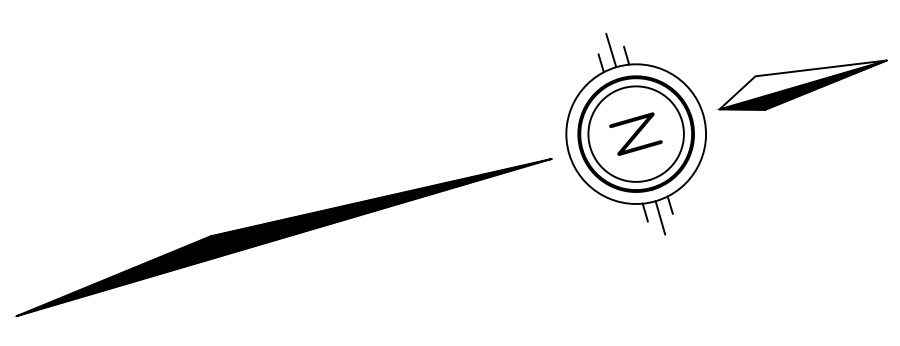

GEODETIC BM ELEV. = 110.298m
ELEVATIONS ARE OF GEODETIC ORIGIN (CGVD-1928-78), AND ARE DERIVED FROM GEODETIC BENCHMARK 001196SU107 NEAR THE SOUTH-EAST CORNER OF ROSEDALE SCHOOL.

NOTE TO CONTRACTOR :
DO NOT SCALE DRAWINGS.
CONTRACTORS MUST CHECK AND VERIFY ALL DIMENSIONS AND REPORT ANY DISCREPANCIES TO THE ENGINEER BEFORE PROCEEDING WITH THE WORK.
ALL DRAWINGS REMAIN THE PROPERTY OF THE ENGINEER AND SHALL NOT BE REPRODUCED OR REUSED WITHOUT THE ENGINEER'S WRITTEN PERMISSION.

THE OWNER/ARCHITECT/CONTRACTOR IS ADVISED THAT M.T.E. CONSULTANTS INC. CANNOT CERTIFY ANY COMPONENT OF THE SITE WORKS NOT INSPECTED DURING CONSTRUCTION. IT IS THE RESPONSIBILITY OF THE GENERAL CONTRACTOR TO NOTIFY M.T.E. CONSULTANTS INC. PRIOR TO COMMENCEMENT OF CONSTRUCTION TO ARRANGE FOR INSPECTION.

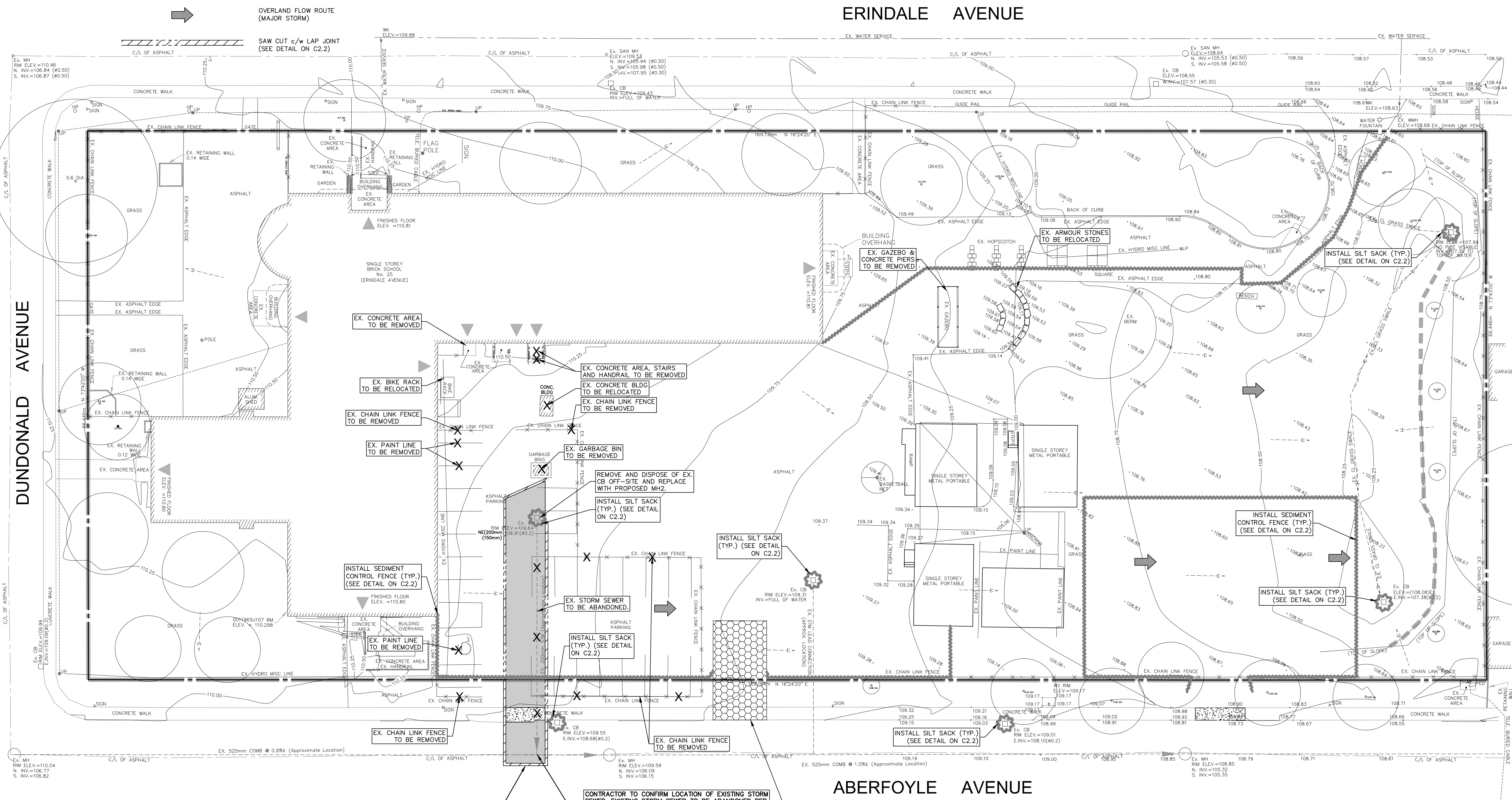

12.	ISSUED FOR TENDER	GPB	APR. 25/24
11.	ISSUED FOR TENDER	GPB	MAR. 28/24
10.	REISSUED FOR BUILDING PERMIT	GPB	JAN. 12/24
9.	REISSUED FOR SPA	GPB	NOV. 20/23
8.	REISSUED FOR SPA	KRR	APR. 23/19
7.	REISSUED FOR SPA	KRR	MAR. 08/19
6.	REISSUED FOR SPA	KRR	FEB. 04/19
5.	ISSUED FOR BUILDING PERMIT	KRR	APR. 23/19
4.	REISSUED FOR SPA	KRR	DEC. 24/18
3.	ISSUED FOR PERMITS	KRR	NOV. 09/18
2.	REISSUED FOR SPA	KRR	OCT. 24/18
1.	ISSUED FOR SPA	KRR	APR. 19/18
No.	REVISION	BY	DATE



Engineers | Scientists | Surveyors

(905) 639-2552 www.mte85.com

NOT FOR CONSTRUCTION



118 JAMES STREET NORTH HAMILTON
PROJECT
ROSEDALE ELEM. SCHOOL RENOVATION CIVIL WORKS
25 ERINDALE AVENUE HAMILTON

EXISTING CONDITIONS, REMOVALS & ESC PLAN

Project Manager	K.RAMSEWAK	Project No.	43438-100
Design By	ALP	Checked By	JRA/KRR
Drawn By	SDU	Checked By	JRA/KRR
Surveyed By	OTHERS	Drawing No.	C1.1
Date	Mar.28/24	Scale	1:250
Sheet	1 of 3		

SAW CUT AND REMOVE EXISTING ASPHALT, CURB AND GUTTER AND BOULEVARD. RESTORE PER CITY OF HAMILTON STANDARD DRAWINGS RD-100.01 AND RD-100.02. GRADES TO MATCH EXISTING AND RESTORE LINE PAINTING AS REQUIRED. EXISTING SIDEWALK TO BE REMOVED AND RESTORED PER CITY OF HAMILTON DRAWINGS RD-124 AND OPSD 310.010.

CONTRACTOR TO CONFIRM LOCATION OF EXISTING STORM SEWER. EXISTING STORM SEWER TO BE ABANDONED PER CITY OF HAMILTON STANDARDS AND REMOVED FROM EXISTING CONNECTION AT MAIN AND EXISTING CATCH BASIN ON-SITE. REPORT ANY DIFFICULTIES TO THE ENGINEER PRIOR TO CONSTRUCTION. CCTV OF EXISTING STORM LINE TO BE COMPLETED TO IDENTIFY IF THERE ARE ADDITIONAL CONNECTIONS TO THE SEWER. MTE TO BE PROVIDED WITH CCTV REPORT.

CONSTRUCTION ACCESS ON EXISTING ASPHALT. RESTORE EXISTING ASPHALT, CURB & BOULEVARD AS PER CITY OF HAMILTON STANDARD DRAWINGS RD-100.01 & RD-100.02. EXISTING SIDEWALK TO BE RESTORED PER CITY OF HAMILTON DRAWINGS RD-100.03

LEGEND OF PROPOSED FEATURES

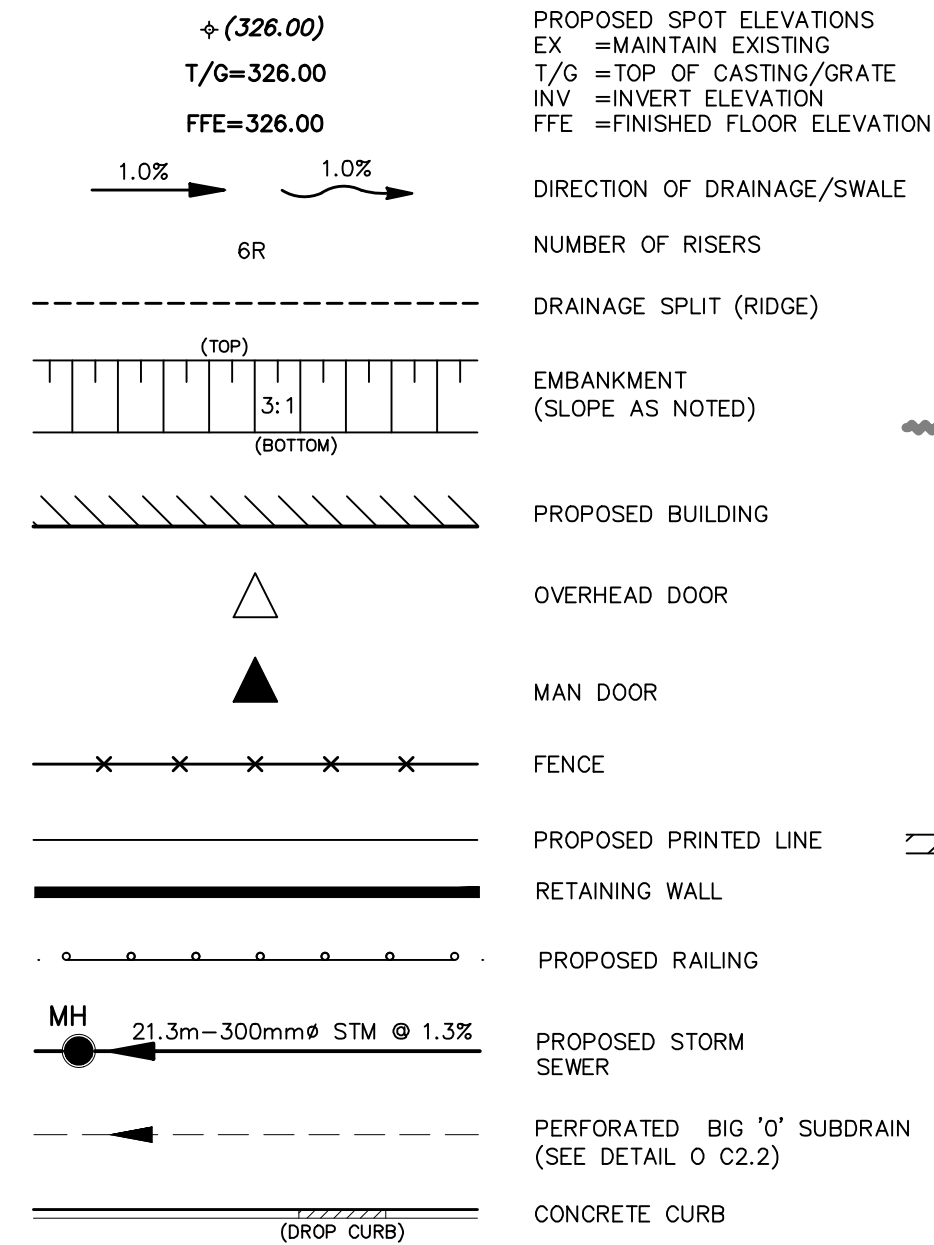

PROPOSED MOLOKS

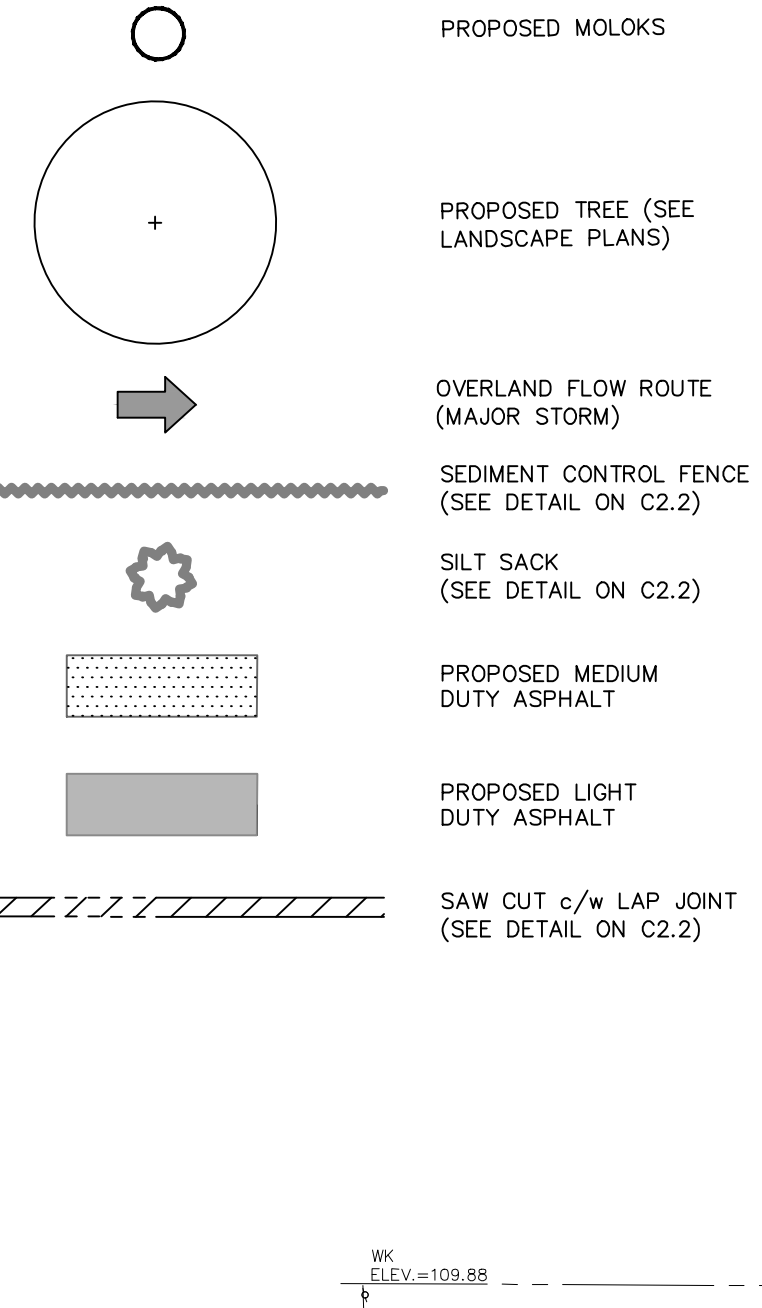

LEGEND OF EXISTING FEATURES

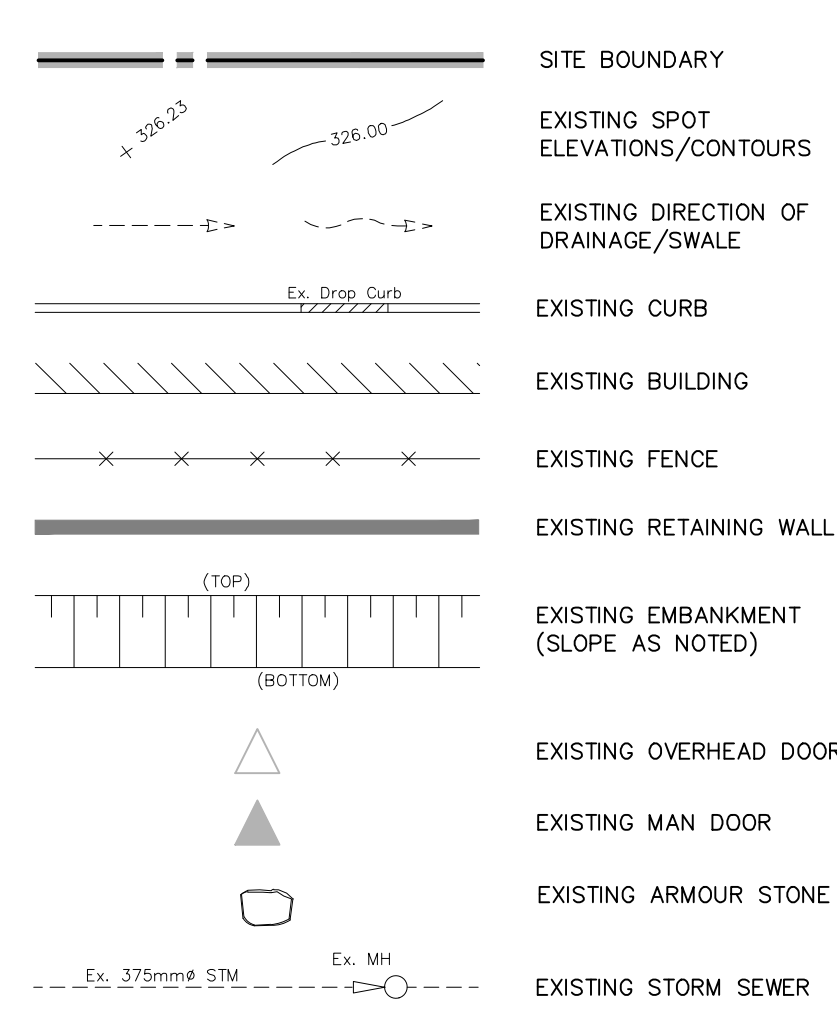

TEMPORARY GRAVEL PARKING LOT

MATERIAL	DEPTH (mm)
GRANULAR 'A' BASE	150
GRANULAR 'B' SUBBASE	250

GRADING NOTES

- ANY CHANGES IN GRADES AND CATCH BASINS REQUIRE THE APPROVAL OF THE CITY'S MANAGER OF DEVELOPMENT ENGINEERING.
- ALL DRIVEWAYS FROM PROPERTY LINES FOR THE FIRST 7.5m SHALL BE WITHIN 5% MAXIMUM GRADE, THEREAFTER, ALL DRIVEWAYS SHALL BE WITHIN 10% MAXIMUM GRADES.
- THE APPROVAL OF THIS PLAN DOES NOT EXEMPT THE OWNER'S BONDED CONTRACTOR FROM THE REQUIREMENTS TO OBTAIN THE VARIOUS PERMITS/APPROVALS NORMALLY REQUIRED TO COMPLETE A CONSTRUCTION PROJECT, SUCH AS, BUT NOT LIMITED TO THE FOLLOWING:
 - ROAD CUT PERMITS
 - APPROACH APPROVAL PERMITS
 - COMMITTEE OF ADJUSTMENT
 - SEWER/WATER PERMITS
 - RELOCATION OF SERVICES
 - ENCROACHMENT AGREEMENTS (IF REQUIRED)

NOTE TO CONTRACTOR:

PRIOR TO CONSTRUCTION, EXISTING UNDERGROUND UTILITIES TO BE CONFIRMED FOR LOCATION, SIZE AND DEPTHS. INFORMATION TO BE PROVIDED TO THE ENGINEER PRIOR TO CONSTRUCTION.

ERINDALE AVENUE

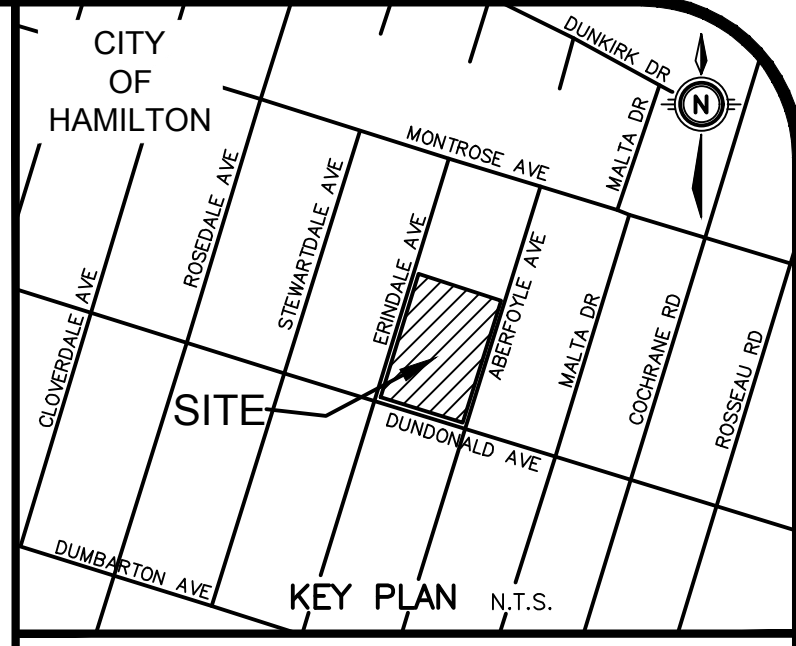
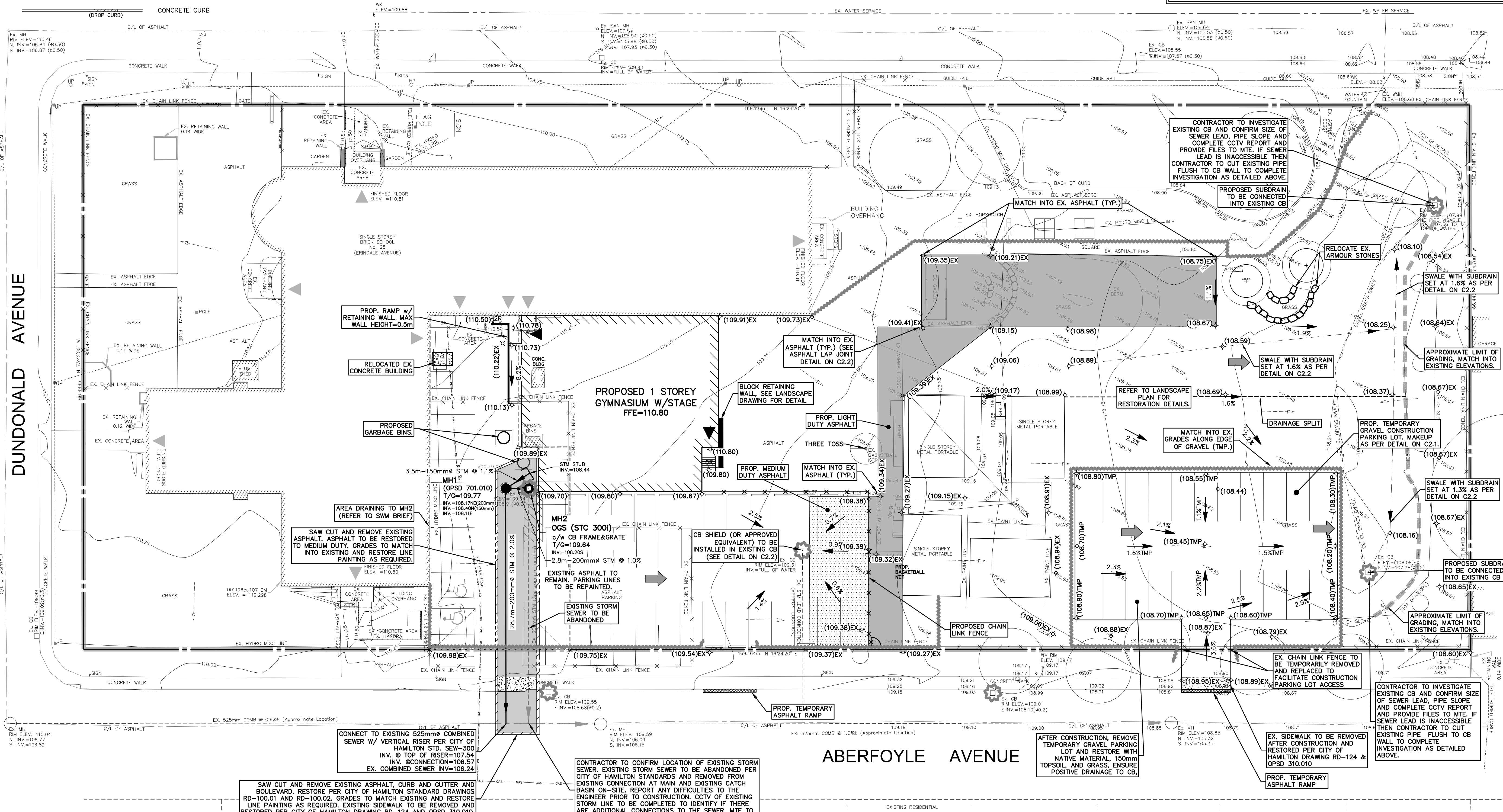

GEODETIC BM ELEV. = 110.298m
ELEVATIONS ARE OF GEODETIC ORIGIN (CGVD-1928-78), AND ARE DERIVED FROM GEODETIC BENCHMARK 0011965U107 NEAR THE SOUTH-EAST CORNER OF ROSEDALE SCHOOL.

NOTE TO CONTRACTOR :
DO NOT SCALE DRAWINGS.
CONTRACTORS MUST CHECK AND VERIFY ALL DIMENSIONS AND REPORT ANY DISCREPANCIES TO THE ENGINEER BEFORE PROCEEDING WITH THE WORK.
ALL DRAWINGS REMAIN THE PROPERTY OF THE ENGINEER AND SHALL NOT BE REPRODUCED OR REUSED WITHOUT THE ENGINEER'S WRITTEN PERMISSION.
THE OWNER/ARCHITECT/CONTRACTOR IS ADVISED THAT M.T.E. CONSULTANTS INC. CANNOT CERTIFY ANY COMPONENT OF THE SITE WORKS NOT INSPECTED DURING CONSTRUCTION. IT IS THE RESPONSIBILITY OF THE GENERAL CONTRACTOR TO NOTIFY M.T.E. CONSULTANTS INC. PRIOR TO COMMENCEMENT OF CONSTRUCTION TO ARRANGE FOR INSPECTION.

No.	REVISION	BY	DATE
12.	ISSUED FOR TENDER	GPB	APR. 25/24
11.	ISSUED FOR TENDER	GPB	MAR. 28/24
10.	REISSUED FOR BUILDING PERMIT	GPB	JAN. 12/24
9.	REISSUED FOR SPA	GPB	NOV. 20/23
8.	REISSUED FOR SPA	KRR	APR. 23/19
7.	REISSUED FOR SPA	KRR	MAR. 08/19
6.	REISSUED FOR SPA	KRR	FEB. 04/19
5.	ISSUED FOR BUILDING PERMIT	KRR	JAN. 23/19
4.	REISSUED FOR SPA	KRR	DEC. 24/18
3.	ISSUED FOR PERMITS	KRR	NOV. 09/18
2.	REISSUED FOR SPA	KRR	OCT. 24/18
1.	ISSUED FOR SPA	KRR	APR. 19/18

(905) 639-2552 www.mte85.com

NOT FOR CONSTRUCTION

CLIENT: **CGS** CURRAN | GACESA | SLOTE ARCHITECTS
118 JAMES STREET NORTH HAMILTON
PROJECT: **ROSEDALE ELEM. SCHOOL RENOVATION CIVIL WORKS**
25 ERINDALE AVENUE HAMILTON

SITE GRADING & SERVICING PLAN

Project Manager	K.RAMSEWAK	Project No.	43438-100
Design By	ALP	Checked By	JRA/KRR
Drawn By	SDU	Checked By	JRA/KRR
Surveyed By	OTHERS	Drawing No.	
Date	Mar.28/24	C2.1	
Scale	1:250	Sheet 2 of 3	

CONSTRUCTION NOTES AND SPECIFICATIONS

1. GENERAL
 - 1.1. THIS PLAN IS NOT FOR CONSTRUCTION UNTIL SIGNED AND SEALED BY ENGINEER AND APPROVED BY THE CITY OF HAMILTON.
 - 1.2. THIS PLAN IS TO BE USED FOR GRADING AND SERVING ONLY; ANY OTHER INFORMATION SHOWN IS FOR ILLUSTRATION PURPOSES ONLY. THIS PLAN MUST NOT BE USED TO SITE THE PROPOSED BUILDING.
 - 1.3. NO CHANGES ARE TO BE MADE WITHOUT THE APPROVAL OF THE DESIGN ENGINEER.
 - 1.4. THIS PLAN IS NOT TO BE REPRODUCED IN WHOLE OR IN PART WITHOUT THE PERMISSION OF MTE CONSULTANTS INC.
 - 1.5. THE APPROVAL OF THIS PLAN DOES NOT EXEMPT THE OWNER'S BONDED CONTRACTOR FROM THE REQUIREMENTS TO OBTAIN THE VARIOUS PERMITS NORMALLY REQUIRED TO COMPLETE A CONSTRUCTION PROJECT, SUCH AS, BUT NOT LIMITED TO THE FOLLOWING:
 - 1.5.1. ROAD CUT PERMIT
 - 1.5.2. APPROACH APPROVAL PERMITS
 - 1.5.3. COMMITTEE OF ADJUSTMENT
 - 1.5.4. SEWER PERMITS
 - 1.5.5. RELOCATION OF SERVICES
 - 1.5.6. ENCROACHMENT AGREEMENTS
 - 1.6. PRIOR TO CONSTRUCTION, THE CONTRACTOR MUST:
 - 1.6.1. CHECK AND VERIFY ALL EXISTING CONDITIONS, LOCATIONS AND ELEVATIONS WHICH ARE NOT LIMITED TO THE BENCHMARK ELEVATIONS, EXISTING SERVICE CONNECTIONS AND EXISTING INVERTS. REPORT ALL DISCREPANCIES TO THE ENGINEER PRIOR TO PROCEEDING.
 - 1.6.2. OBTAIN ALL UTILITY LOCATES AND REQUIRED PERMITS AND LICENSES.
 - 1.6.3. VERIFY THAT THE FINISHED FLOOR ELEVATIONS AND BASEMENT FLOOR ELEVATIONS (WHICH MAY APPEAR ON THIS PLAN) COMPLY WITH THE FINAL ARCHITECTURAL DRAWINGS.
 - 1.6.4. CONFIRM ALL DRAWINGS USED FOR CONSTRUCTION ARE OF THE MOST RECENT REVISION.
 - 1.7. THE CONTRACTOR SHALL ASSUME ALL LIABILITY FOR ANY DAMAGE TO EXISTING WORKS.
 - 1.8. ALL WORKS ON A MUNICIPAL RIGHT-OF-WAY WILL BE INSTALLED BY CITY OF HAMILTON'S BONDED CONTRACTOR UPON APPLICATION BY THE GENERAL CONTRACTOR AT THE GENERAL CONTRACTOR'S EXPENSE. UNDER THE ROAD CUT PERMIT, THE CONTRACTOR IS TO MAKE CONNECTION TO THE SERVICES AND MAKE AND MAINTAIN THE TEMPORARY REPAIR OVER THE CUT, WITH PERMANENT REPAIR BEING MADE BY THE CITY OF HAMILTON'S BONDED CONTRACTOR AT THE GENERAL CONTRACTOR'S COST. THE CONTRACTOR IS RESPONSIBLE FOR RESTORATION OF ALL BOULEVARD AREAS.
 - 1.9. CONSTRUCTION OF SEWERS, WATERMANS AND RELATED APPURTENANCES SHALL BE UNDERTAKEN IN ACCORDANCE WITH THE CITY OF HAMILTON CONSTRUCTION AND MATERIALS SPECIFICATIONS MANUAL (LATEST EDITION), THE ONTARIO PROVINCIAL STANDARD DRAWINGS (OPSD) AND MINISTRY OF THE ENVIRONMENT GUIDELINES (LATEST EDITION), THE CITY DRAWINGS SHALL TAKE PRECEDENT OVER THE OPSD DRAWINGS.
 - 1.10. ALL SEWERS ARE TO BE INSTALLED WITH A MINIMUM COVER OF 2.20m AT THE PROPERTY LINE BELOW THE FINAL ROAD GRADE OR AT SUCH HIGHER ELEVATION ONLY AS MAY BE NECESSITATED BY THE ELEVATION OF THE MAIN SEWER ON PRIVATE PROPERTY THE MINIMUM COVER IS TO BE NO LESS THAN 1.2m.
 - 1.11. INFORMATION REGARDING ANY EXISTING SERVICES AND/OR UTILITIES SHOWN ON THE APPROVED SET OF CONSTRUCTION DRAWINGS IS FURNISHED AS THE BEST AVAILABLE INFORMATION. THE CONTRACTOR SHALL INTERPRET THIS INFORMATION AS HE SEES FIT WITH THE UNDERSTANDING THAT THE OWNER AND HIS AGENTS DISCLAIM ALL RESPONSIBILITY FOR ITS ACCURACY AND/OR SUFFICIENCY.
 - 1.12. NO BLASTING WILL BE PERMITTED.
 - 1.13. ALTERNATIVE MATERIALS WILL NOT BE ALLOWED UNLESS FIRST APPROVED IN WRITING BY THE CONSULTANT AND THE CITY OF HAMILTON.
 - 1.14. APPROVED FILL, FREE OF DELETERIOUS AND ORGANIC MATERIAL AND BOULDERS SHALL BE COMPACTED TO A DRY DENSITY NOT LESS THAN 95% OF THE STANDARD PROCTOR DENSITY. AFTER COMPACTION, SOIL DENSITY TESTS SHALL BE CONDUCTED TO ENSURE ADEQUATE COMPACTION AND STABILITY OF THE FILL AND TEST RESULTS SHALL BE SUBMITTED TO THE ENGINEER.
 - 1.15. CONTRACTOR IS RESPONSIBLE FOR CONTACTING ENGINEER 48 HRS PRIOR TO COMMENCING WORK TO ARRANGE FOR INSPECTION. ENGINEER TO DETERMINE DEGREE OF INSPECTION AND TESTING REQUIRED FOR CERTIFICATION OF UNDERGROUND SERVICE INSTALLATION AS MANDATED BY ONTARIO BUILDING CODE DIVISION C, PART 1, SECTION 1.2.2, GENERAL REVIEW. FAILURE TO NOTIFY ENGINEER WILL RESULT IN EXTENSIVE POST CONSTRUCTION INSPECTION AT CONTRACTORS EXPENSE.
 - 1.16. PLAN TO BE READ IN CONJUNCTION WITH SWM BRIEF AND DRAWING C1.1 PREPARED BY MTE CONSULTANTS INC.
 - 1.17. SITE PLAN INFORMATION TAKEN FROM PLAN PREPARED BY THIER + CURRAN ARCHITECTS INC., DATED OCTOBER 11, 2023.
 - 1.18. EXISTING TOPOGRAPHIC AND LEGAL INFORMATION TAKEN FROM PLAN PREPARED BY MATTHEWS, CAMERON, HEYWOOD-KERRY T. HOWE, DATED AUGUST 13, 2018. MTE ASSUMES THAT ALL TOPOGRAPHICAL INFORMATION IS AN ACCURATE REPRESENTATION OF CURRENT CONDITIONS.
 - 1.19. RETAINING WALLS TO BE DESIGNED BY OTHERS. FOR WALLS EXCEEDING 1.0m IN HEIGHT, SHOP DRAWINGS MUST BE SUBMITTED FOR REVIEW AND APPROVAL. BUILDING PERMIT MUST BE OBTAINED. WALLS OVER 0.6m IN HEIGHT REQUIRE GUARDS. HIGH SIDE OF RETAINING WALLS TO BE BACKFILLED WITH FREE DRAINING MATERIAL.
 - 1.20. SITE SERVING CONTRACTOR TO TERMINATE ALL SERVICES 1.0 METRES FROM FOUNDATION WALL.
 - 1.21. FILTER FABRIC TO BE TERRAFIX 200R OR APPROVED EQUIVALENT.
 - 1.22. MAXIMUM GRASSED SLOPE TO BE 3:1. SLOPES GREATER THAN 3:1 TO BE LANDSCAPED WITH LOW MAINTENANCE GROUND COVER.
 - 1.23. THE CONTRACTOR SHALL BE RESPONSIBLE FOR ALL TRAFFIC AND SAFETY MEASURES DURING THE CONSTRUCTION PERIOD INCLUDING THE SUPPLY, INSTALLATION AND REMOVAL OF ALL NECESSARY SIGNALS, DELINEATORS, MARKERS, AND BARRIERS. ALL SIGNS, ETC. SHALL CONFORM TO THE STANDARDS OF THE CITY OF HAMILTON AND THE MTO MANUAL OF UNIFORM TRAFFIC CONTROL DEVICES.
 - 1.24. THE POSITION OF POLE LINES, CONDUITS, WATERMANS, SEWERS AND OTHER UNDERGROUND AND OVERGROUND UTILITIES AND STRUCTURES IS NOT NECESSARILY SHOWN ON THE CONTRACT DRAWINGS, AND, WHERE SHOWN, THE GENERAL CONTRACTOR SHALL, UPON VERBAL AND/OR WRITTEN REQUEST BY THE CITY, IMMEDIATELY PROCEED WITH CLEAN-UP OPERATIONS AT THEIR EXPENSE. SHOULD THE GENERAL CONTRACTOR FAIL TO MAINTAIN THE ROAD AS DIRECTED, THE CITY WILL HAVE THE CLEANING CARRIED OUT, AND LAY CHARGES.
- 1.25. FOLLOWING COMPLETION OF PROPOSED WORKS AND PRIOR TO OCCUPANCY INSPECTION, ALL STORM AND SANITARY SEWERS ARE TO BE FLUSHED, AND ALL CATCHBASIN AND CATCHBASIN MANHOLE SUMPS ARE TO BE CLEANED OF DEBRIS AND SILT.
- 1.26. APPROVAL OF THIS DRAWING IS FOR MATERIAL ACCEPTABILITY AND COMPLIANCE WITH MUNICIPAL AND PROVINCIAL SPECIFICATIONS AND STANDARDS AND APPROVAL AND INSPECTION BY THE CITY OF THE WORKS DOES NOT CERTIFY THE LINE AND GRADE OF THE WORKS AND IT IS THE OWNER'S RESPONSIBILITY TO HAVE THEIR ENGINEER CERTIFY THIS ACCORDINGLY.

2. STORM SEWERS
 - 2.1. PIPE BEDDING FOR RIGID PIPE TO BE CLASS "B" AS PER OPSD 802.030. PIPE BEDDING FOR FLEXIBLE PIPE TO BE AS PER OPSD 802.010. BEDDING MATERIAL AND COVER MATERIAL TO BE GRAN. "A". TRENCH BACKFILL TO BE NATIVE MATERIAL REPLACED IN 300mm LIFTS AND COMPACTED TO 95% STANDARD PROCTOR DENSITY.
 - 2.2. STORM SEWERS, 150mm AND SMALLER, SHALL BE POLYVINYL CHLORIDE (PVC) PIPE SDR28 ASTM-D3034 WITH INTEGRAL BELL AND SPIGOT UTILIZING FLEXIBLE ELASTOMERIC SEALS.
 - 2.3. STORM SEWERS 200mm TO 375mm SHALL BE POLYVINYL CHLORIDE (PVC) PIPE SDR28 ASTM-D3034 WITH INTEGRAL BELL AND SPIGOT UTILIZING FLEXIBLE ELASTOMERIC SEALS.
 - 2.4. MANHOLES AND MANHOLE CATCHBASINS TO BE 1200mm DIAMETER PRECAST WITH ALUMINIUM STEPS AT 300mm CENTRES AS PER OPSD 701.010 UNLESS OTHERWISE SPECIFIED. (NO SUMPS)
 - 2.13. CATCHBASINS TO HAVE A MINIMUM 600mm DEEP SUMP. WHEN THE STRUCTURE INCLUDES THE INSTALLATION OF A SNOOT (OR APPROVED EQUIVALENT) THE SUMP DEPTH TO BE MIN 2.5 TIMES THE OUTLET PIPE DIAMETER SIZE.
 - 2.14. MANHOLE AND CATCHBASIN, FRAMES, GRATES, CASTINGS AND LIDS TO BE QUALITY GREY IRON ASTM A48 CLASS 30B.
 - 2.15. STORM MANHOLE LIDS TO BE PER OPSD 401.010 - TYPE 'B' CATCHBASIN AND CATCHBASIN MANHOLE GRATES TO BE PER OPSD 400.100.
 - 2.16. STORM SEWERS AND SERVICES TO HAVE MINIMUM 1.2m COVER TO TOP OF PIPE.
 - 2.17. PROPOSED SINGLE CATCH BASINS ARE TO BE AS OPSD 705.010 MODIFIED WITH A GOSS TRAP AS PER SEW-304.
 - 2.18. MINIMUM HORIZONTAL SEPARATION BETWEEN WATER SERVICES/MAINS AND SEWER DRAINS AND MUNICIPAL SEWER MAINS SHALL BE 2.5M MEASURED FROM THE CLOSEST PIPE EDGE TO CLOSEST PIPE EDGE. VERTICAL SEPARATION WHERE WATER SERVICE/MAIN PASSES OVER A SEWER DRAIN OR MUNICIPAL SEWER MAIN MUST BE A MINIMUM OF 0.15M UNLESS GREATER SEPARATION IS REQUIRED TO PROVIDE FOR PROPER BEDDING AND STRUCTURAL SUPPORT. WATER SERVICES/MAINS PASSING UNDER SEWER DRAINS OR MUNICIPAL SEWER MAINS MUST HAVE A SEPARATION OF 0.5M BETWEEN THE INVERT OF THE SEWER MAIN/DRAIN AND THE CROWN OF THE WATERSERVICE/MAIN.

3. GRADING NOTES
 - 3.1. ANY CHANGES IN GRADES AND CATCH BASINS REQUIRE THE APPROVAL OF THE DIRECTOR OF DEVELOPMENT ENGINEERING, PLANNING AND ECONOMIC DEVELOPMENT DEPARTMENT.
 - 3.2. FILTER FABRIC TO BE TERRAFIX 270R OR APPROVED EQUAL.
 - 3.3. MAXIMUM GRASSED SLOPE TO BE 3:1. SLOPES GREATER THAN 3:1 TO BE LANDSCAPED WITH LOW MAINTENANCE GROUND COVER.
 - 3.4. MINIMUM ASPHALT GRADE TO BE 1.0%, MINIMUM GUTTERLINE GRADE TO BE 0.5%.
 - 3.5. CONTRACTOR TO MATCH EXISTING GRADES AT PROPERTY LINE UNLESS OTHERWISE NOTED.
 - 3.6. ALL DRIVEWAYS FROM PROPERTY LINES FOR THE FIRST 7.5m SHALL BE WITHIN 5% MAX. GRADE. THEREAFTER, ALL DRIVEWAYS SHALL BE WITHIN 10% MAXIMUM GRADES.
 - 3.7. PRIOR TO REMOVING ANY EXCESS SOILS FROM THE SITE, CONTRACTOR TO CONTACT THE ARCHITECT FOR DIRECTION ON CREATING EARTHEN BERMS ON-SITE.
 - 3.8. ALL LANDSCAPED AREAS ARE TO HAVE A MINIMUM 2.0% SLOPE.
4. RESTORATIONS
 - 4.1. ALL RESTORATIONS TO CONFORM TO HAMILTON FORM 300.30.
 - 4.2. RESTORATIONS OF ROAD OVER UTILITY CUTS IN HAMILTON TO BE AS PER STANDARD DRAWINGS RD-100.01 AND RD-100.02, WITH GRANULAR "A" BEDDING. THE CONTRACTOR MUST BE BONDED WITH THE CITY OF HAMILTON AND MAKE AND MAINTAIN THE TEMPORARY ROAD REPAIR OVER THE CUT, WITH PERMANENT REPAIR BEING MADE BY THE CITY CONTRACTOR AT THE OWNER/OWNER'S CONTRACTOR COST.
 - 4.3. ALL BOULEVARDS TO BE RESTORED WITH #1 NURSERY SOD ON A MINIMUM 100mm OF SELECT TOPSOIL.
 - 4.4. CONTRACTOR SHALL CO-ORDINATE THE REMOVAL AND REINSTALLATION OF EXISTING PARKING METERS AND/OR STREET SIGNS WITH THE CITY OF HAMILTON TRAFFIC DEPARTMENT.
 - 4.5. ALL FENCES AFFECTED BY CONSTRUCTION SHALL BE REMOVED, TEMPORARILY RELOCATED AND/OR STOCKPILED IF APPROVED BY THE ENGINEER, AND REINSTATED UPON COMPLETION OF CONSTRUCTION.

5. EROSION AND SEDIMENT CONTROL
 - 5.1. CONTRACTOR TO INSTALL EROSION CONTROL MEASURES AS SHOWN PRIOR TO CONSTRUCTION AND MAINTAIN IN GOOD CONDITION UNTIL CONSTRUCTION IS COMPLETED AND VEGETATIVE COVER IS ESTABLISHED. BUT PRIOR TO FENCE BECOMING OVERGROWN, ENGINEER'S REPRESENTATIVE TO DETERMINE IF VEGETATION HAS REACHED THE CRITICAL POINT AND WILL THEN INSTRUCT CONTRACTOR TO REMOVE FENCE.
 - 5.2. ALL EROSION AND SEDIMENT CONTROL MEASURES (TEMPORARY SEDIMENT CONTROL FENCES, STORM SEWER BULKHEADS, ROCK CHECK DAMS, WORK LIMIT FENCES, SEDIMENT BASINS, ETC.) MUST BE INSTALLED PRIOR TO COMMENCEMENT OF CONSTRUCTION.
 - 5.3. TEMPORARY VEHICLE TRACKING CONTROLS TO BE CONSTRUCTED AS PER REQUIREMENTS IN "EROSION & SEDIMENT CONTROL GUIDELINE FOR URBAN CONSTRUCTION" DATED DECEMBER 2006, AT ALL ACCESS POINTS. CONTRACTOR SHALL MAINTAIN THESE AS REQUIRED AND AS DIRECTED BY THE CITY ENGINEER. MUD MATS TO BE PROVIDED ON-SITE AT ALL LOCATIONS WHERE CONSTRUCTION VEHICLES EXIT THE SITE. CONTRACTOR TO ENSURE ALL VEHICLES LEAVE THE SITE VIA THE MUD MAT AND THAT THE MAT IS MAINTAINED IN A MANNER TO MAXIMIZE EFFECTIVENESS AT ALL TIMES.
 - 5.4. THE GENERAL CONTRACTOR IS RESPONSIBLE FOR THE REMOVAL OF ALL MUD AND DEBRIS THAT ARE TRACKED ONTO THE ROADWAYS FROM VEHICLES ENTERING OR LEAVING THE CONSTRUCTION SITE. THE GENERAL CONTRACTOR SHALL, UPON VERBAL AND/OR WRITTEN REQUEST BY THE CITY, IMMEDIATELY PROCEED WITH CLEAN-UP OPERATIONS AT THEIR EXPENSE. SHOULD THE GENERAL CONTRACTOR FAIL TO MAINTAIN THE ROAD AS DIRECTED, THE CITY WILL HAVE THE CLEANING CARRIED OUT, AND LAY CHARGES.
 - 5.5. OVERLAND SHEET FLOW EROSION PROTECTION SHALL BE AS PER OPSD 219.130. IF EXCESSIVE SEDIMENT BUILDUP/BLOCKAGE OCCURS (VISUAL INSPECTION) THEN REPLACEMENT OF THE FILTER CLOTH IS REQUIRED.

- 5.6. CATCH BASIN SEDIMENT CONTROL DEVICE, I.E. "SILTSACK" BY ACF ENVIRONMENT OR APPROVED EQUIVALENT, TO BE PLACED AS PER MANUFACTURER'S RECOMMENDATIONS (SEE DETAIL). REGULAR MAINTENANCE IS REQUIRED ("SILTSACK" SUMPS SHALL BE INSPECTED FOR SEDIMENT ACCUMULATION AND FILTER CLOTH BLOCKAGE ON A WEEKLY BASIS). THESE SEDIMENT TRAPS ARE NOT TO BE REMOVED UNTIL THE CURBS AND THE BOULEVARDS SODDED. SEDIMENT TRAPS SHALL ALSO BE PLACED AS PER DETAIL AT ALL CATCH BASIN LOCATIONS IN AREAS TO BE VEGETATED AND MAINTAINED UNTIL GROUND COVER IS ESTABLISHED.
- 5.7. ALL SILT FENCING TO BE INSTALLED PRIOR TO ANY AREA GRADING, EXCAVATING OR DEMOLITION COMMENCING. SILT FENCE OVER ASPHALT TO BE INSTALLED PER DETAIL PROVIDED OR AS TERRAFIX SILT SOCK.
- 5.8. EROSION CONTROL FENCING TO BE INSTALLED AROUND BASE OF ALL STOCKPILES. IF INSUFFICIENT SPACE FOR MATERIAL STOCKPILING, THE GENERAL CONTRACTOR IS TO CARRY THE COSTS FOR OFFSITE STORAGE AND REPLACEMENT.
- 5.9. TOPSOIL PILES SHALL BE TEMPORARILY SEEDED TO PREVENT EROSION. PLACEMENT OF VEGETATION SHALL BE IN ACCORDANCE WITH OPS5.572. WHERE REQUIRED, EROSION CONTROL BLANKETS SHALL BE PLACED AS PER OPS5.572, AT THE DIRECTION OF THE CITY ENGINEER.
- 5.10. ADDITIONAL EROSION CONTROL MEASURES MAY BE REQUIRED AS SITE DEVELOPMENT PROGRESSES. CONTRACTOR TO PROVIDE ALL ADDITIONAL EROSION CONTROL STRUCTURES. EROSION CONTROL STRUCTURES TO REMAIN IN PLACE UNTIL ALL DISTURBED GROUND SURFACES HAVE BEEN RESTABILIZED.
- 5.11. NO ALTERNATE METHODS OF EROSION PROTECTION SHALL BE PERMITTED UNLESS APPROVED BY THE ENGINEER AND THE CITY OF HAMILTON DEPARTMENT OF PUBLIC WORKS.
- 5.12. CONTRACTOR TO CLEAN ROADWAY AND SIDEWALKS OF SEDIMENTS RESULTING FROM CONSTRUCTION TRAFFIC FROM THE SITE EACH DAY.
- 5.13. ALL DISTURBED AREAS NOT SCHEDULED FOR FURTHER CONSTRUCTION WITHIN 45 DAYS WILL BE PROVIDED WITH A SUITABLE TEMPORARY MULCH AND SEED COVER WITHIN 7 DAYS OF THE COMPLETION OF THAT PARTICULAR PHASE OF CONSTRUCTION.
- 5.14. ALL DISTURBED EXTERNAL AREAS SHALL BE REVEGETATED WITH PERMANENT COVER (AS DETAILED) WITHIN 7 DAYS OF THE COMPLETION OF THAT PARTICULAR PHASE OF CONSTRUCTION.
- 5.15. ADDITIONAL EROSION AND SEDIMENT CONTROL LOCATIONS/ MEASURES MAY BE REQUIRED AS DETERMINED BY THE CITY/CONSERVATION AUTHORITY.

6. MAINTENANCE RECOMMENDATIONS
 - 6.1. REMOVE SEDIMENT AND CONTAMINANTS ANNUALLY AND REINSTATE STORM WATER MANAGEMENT FACILITY ACCORDING TO THE DESIGN OUTLINED ON THIS PLAN.
 - 6.2. ALL EROSION AND SEDIMENT CONTROL MEASURES SHALL BE VISUALLY INSPECTED AFTER EACH WORKING DAY AND MAINTAINED WHEN REQUIRED AS DIRECTED BY THE CONSULTANT AND TO THE SATISFACTION OF THE CITY/CONSERVATION AUTHORITY. THE CONSULTANT SHALL KEEP A DAILY RECORD OF INSPECTION, MAINTENANCE, ETC. AND PRESENT THE CITY WITH A COPY OF REPORT ON A MONTHLY BASIS.
 - 6.3. THE GENERAL CONTRACTOR TO ASSIGN A REPRESENTATIVE TO MONITOR EROSION CONTROL STRUCTURES TO ENSURE FENCING IS INSTALLED AND MAINTENANCE IS PERFORMED TO CITY REQUIREMENTS.
 - 6.4. REGULAR MAINTENANCE FOR ALL CATCH BASINS (ON THE PUBLIC ROADWAY AND ON PRIVATE PROPERTY) AND INLET CHAMBERS IS REQUIRED (SEDIMENT TRAPS AND SUMP SHALL BE INSPECTED FOR SEDIMENT ACCUMULATION, TRASH BUILDUP AND FILTER CLOTH BLOCKAGE ON A WEEKLY BASIS AND AFTER ANY MAJOR RAINFALL EVENT) ACCUMULATED SEDIMENT SHALL BE REMOVED BY MECHANICAL MEANS. FLUSHING OF SEDIMENT INTO THE STORM SEWER SYSTEM IS PROHIBITED. IF STANDING WATER REMAINS IN THE CATCH BASIN 24 HOURS (MINIMUM) AFTER A STORM THEN CLEANING OR REPLACEMENT CLOTH IS REQUIRED.

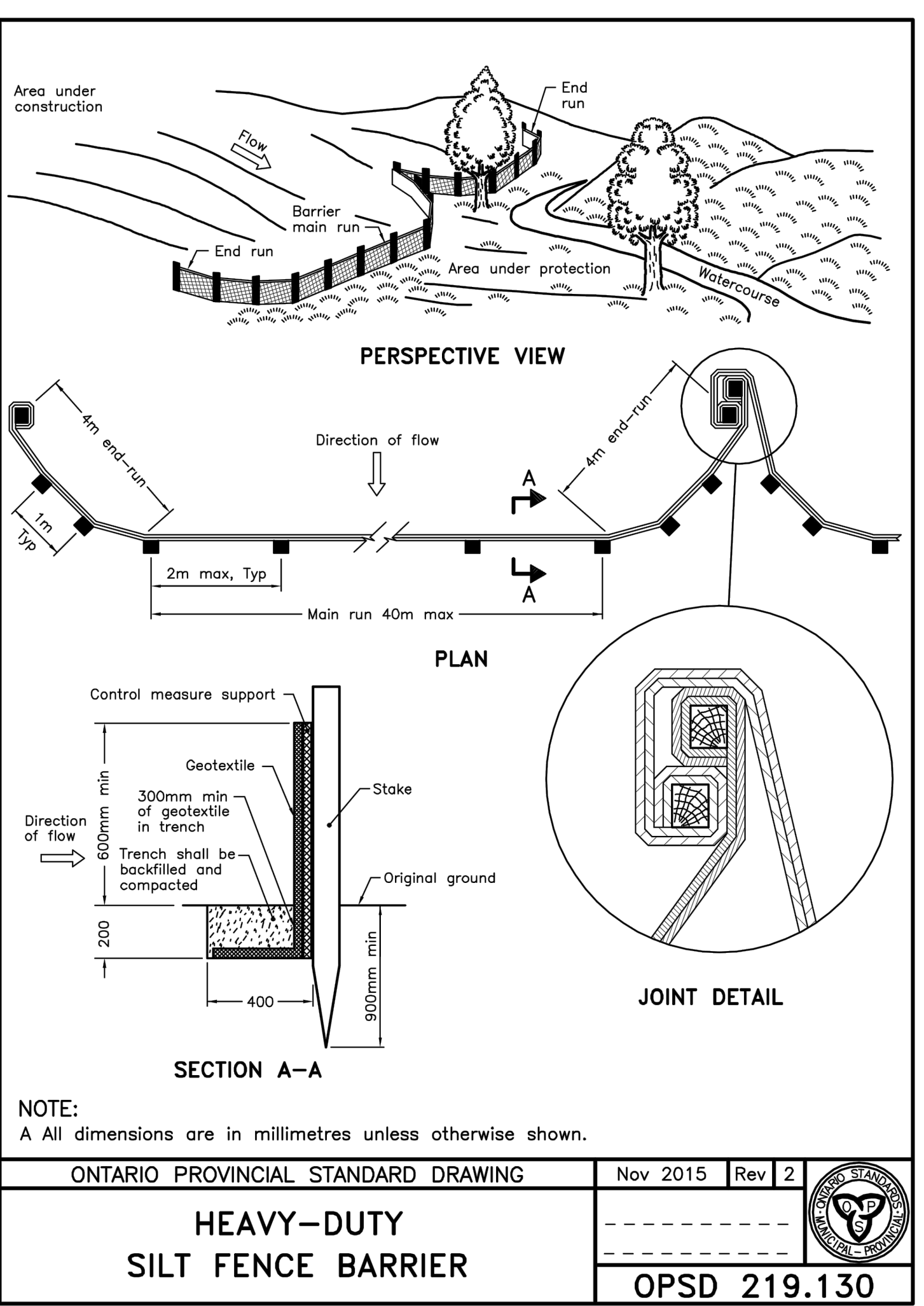

HEAVY-DUTY SILT FENCE BARRIER
OPSD 219.130

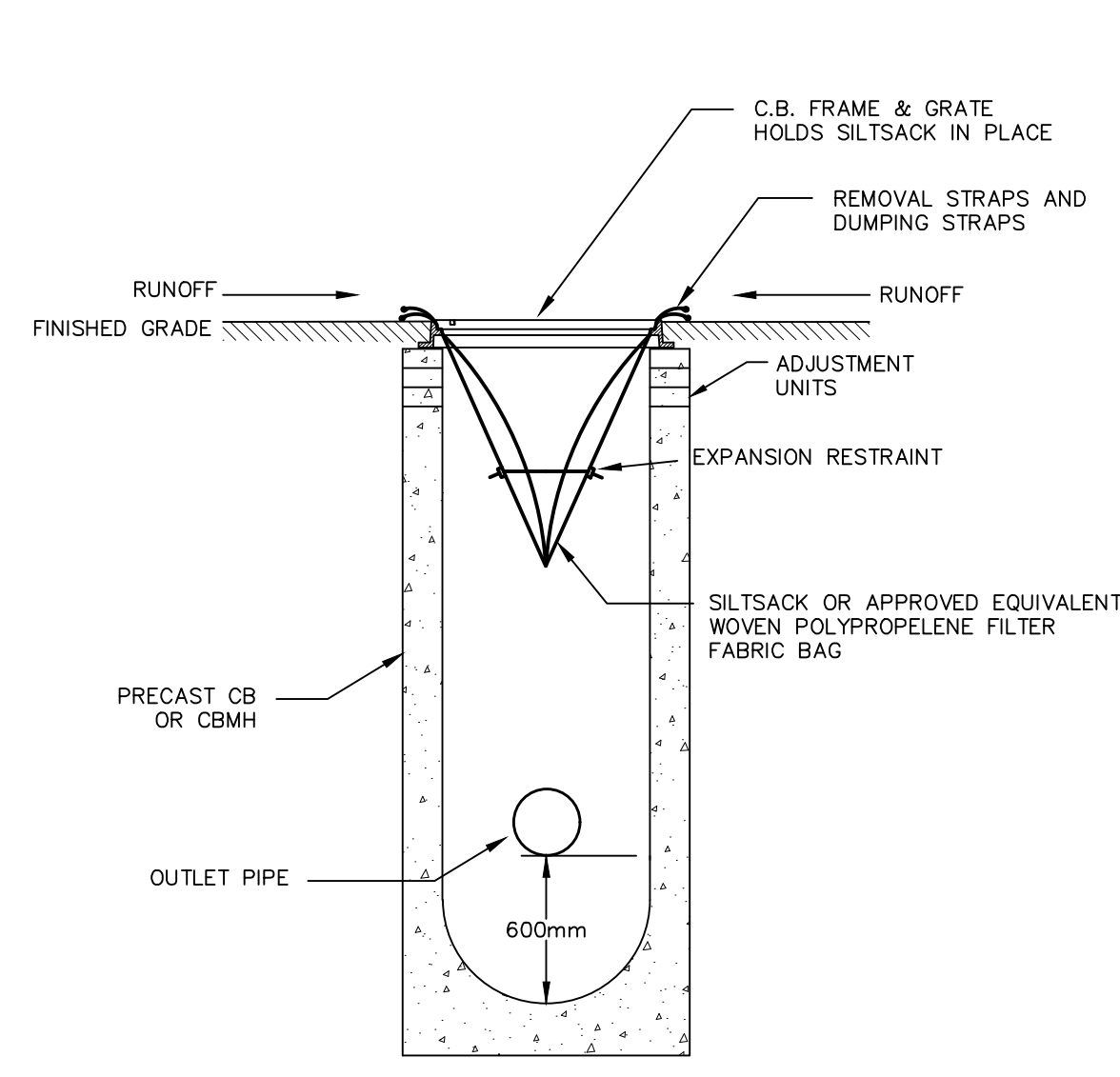

TEMPORARY SILTSACK SILTATION CONTROL IN CB
N.T.S.

MAINTENANCE SCHEDULE

- INSPECT AFTER EVERY MAJOR RAIN EVENT.
- INSPECT EVERY 3 WEEKS MINIMUM.
- SILTSACK SHOULD NEVER BE OVER HALF FULL.
- FULL BAG CAN BE REMOVED, DUMPED, CLEANED AND REUSED (TO REMOVE INSERT 25mm REBAR INTO REMOVAL FLAP POCKETS)
- (TO DUMP INSERT 25mm REBAR INTO BOTH DUMPING STRAPS)

12.	ISSUED FOR TENDER	GPB	APR. 25/24
11.	ISSUED FOR TENDER	GPB	MAR 28/24
10.	REISSUED FOR BUILDING PERMIT	KRR	JAN. 12/24
9.	REISSUED FOR SPA	GPB	NOV. 20/23
8.	REISSUED FOR SPA	KRR	MAR. 23/19
7.	REISSUED FOR SPA	KRR	MAR. 08/19
6.	REISSUED FOR SPA	KRR	FEB. 04/19
5.	ISSUED FOR BUILDING PERMIT	KRR	JAN. 23/19
4.	REISSUED FOR SPA	KRR	DEC. 24/18
3.	ISSUED FOR PERMITS	KRR	NOV. 09/18
2.	REISSUED FOR SPA	KRR	OCT. 24/18
1.	ISSUED FOR SPA	KRR	APR. 19/18
No.	REVISION	BY	DATE

ONTARIO PROVINCIAL STANDARD DRAWING		Nov 2015	Rev 2	
HEAVY-DUTY SILT FENCE BARRIER				
		OPSD 219.130		

- Notes**
- 1 Recommended depth t/g - invert = 1.2m
 - Maximum depth t/g - invert = 2.4m
 1. CB Shield to be installed in non frozen conditions.
 2. The frame and cover should be well aligned with the catchbasin.
 3. The sump must be clean before installation
 4. The grate is at the same elevation as pipe invert.
 5. Pipes must be cut flush with inside walls

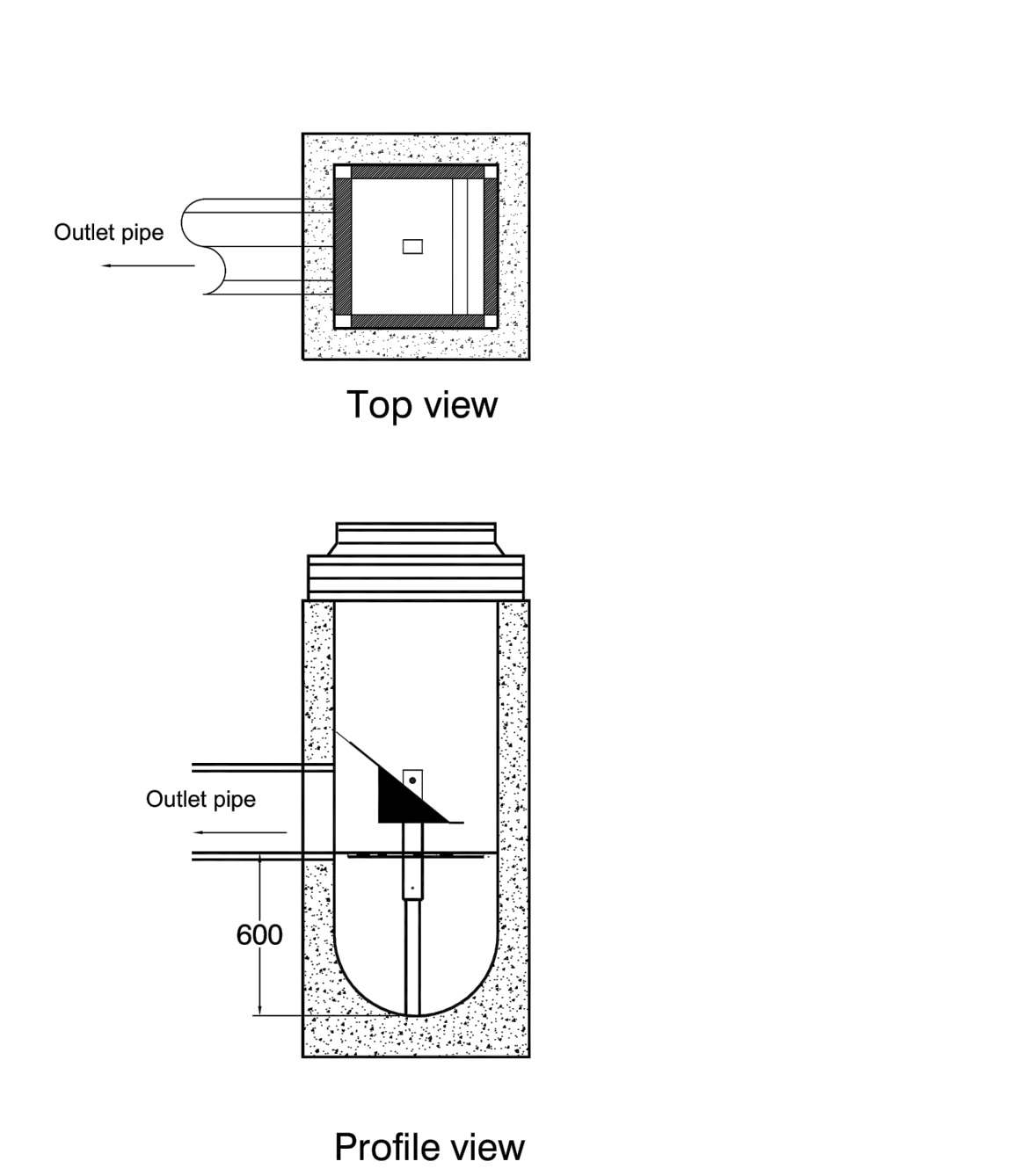

600 x 600 CB Shield (600mm Sump)

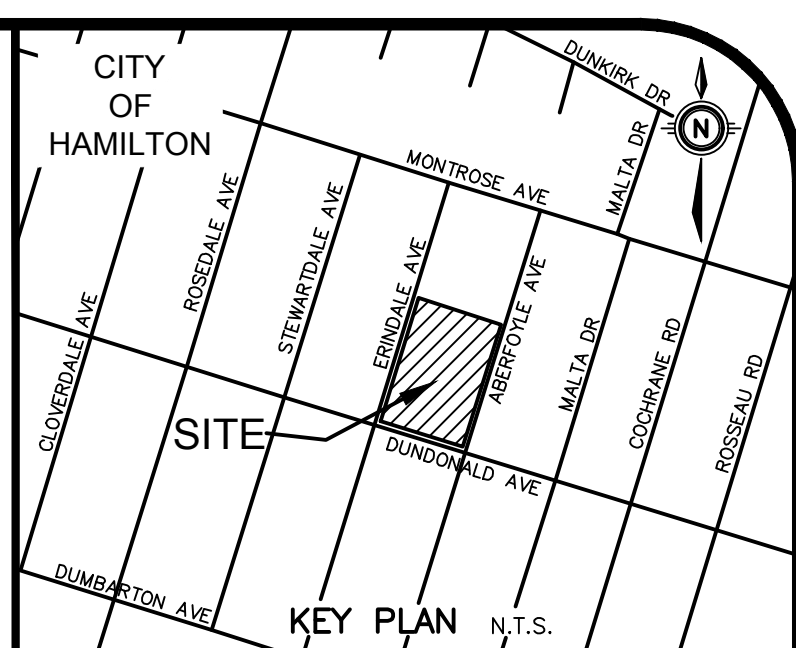
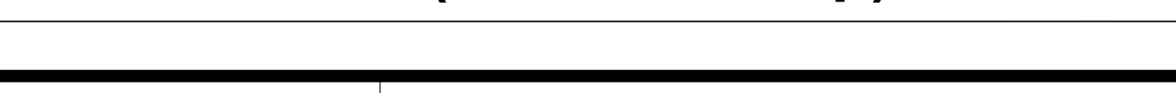

GEODETIC BM ELEV. = 110.298m
ELEVATIONS ARE OF GEODETIC ORIGIN (CGVD-1928-78), AND ARE DERIVED FROM GEODETIC BENCHMARK 0011965U107 NEAR THE SOUTH-EAST CORNER OF ROSEDALE SCHOOL.

NOTE TO CONTRACTOR :
DO NOT SCALE DRAWINGS.
CONTRACTORS MUST CHECK AND VERIFY ALL DIMENSIONS AND REPORT ANY DISCREPANCIES TO THE ENGINEER BEFORE PROCEEDING WITH THE WORK.
ALL DRAWINGS REMAIN THE PROPERTY OF THE ENGINEER AND SHALL NOT BE REPRODUCED OR REUSED WITHOUT THE ENGINEER'S WRITTEN PERMISSION.
THE OWNER/ARCHITECT/CONTRACTOR IS ADVISED THAT M.T.E. CONSULTANTS INC. CANNOT CERTIFY ANY COMPONENT OF THE SITE WORKS NOT INSPECTED DURING CONSTRUCTION. IT IS THE RESPONSIBILITY OF THE GENERAL CONTRACTOR TO NOTIFY M.T.E. CONSULTANTS INC. PRIOR TO COMMENCEMENT OF CONSTRUCTION TO ARRANGE FOR INSPECTION.

12.	ISSUED FOR TENDER	GPB	APR. 25/24
11.	ISSUED FOR TENDER	GPB	MAR 28/24
10.	REISSUED FOR BUILDING PERMIT	KRR	JAN. 12/24
9.	REISSUED FOR SPA	GPB	NOV. 20/23
8.	REISSUED FOR SPA	KRR	MAR. 23/19
7.	REISSUED FOR SPA	KRR	MAR. 08/19
6.	REISSUED FOR SPA	KRR	FEB. 04/19
5.	ISSUED FOR BUILDING PERMIT	KRR	JAN. 23/19
4.	REISSUED FOR SPA	KRR	DEC. 24/18
3.	ISSUED FOR PERMITS	KRR	NOV. 09/18
2.	REISSUED FOR SPA	KRR	OCT. 24/18
1.	ISSUED FOR SPA	KRR	APR. 19/18
No.	REVISION	BY	DATE

CLIENT		CGS		CURRAN GACESA SLOTE ARCHITECTS	
118 JAMES STREET NORTH		HAMILTON		PROJECT	
ROSEDALE ELEM. SCHOOL RENOVATION CIVIL WORKS		HAMILTON		DRAWING	
25 ERINDALE AVENUE		HAMILTON		PROJECT MANAGER	
				K. RAMSEWAK	
				PROJECT NO.	
				43438-100	
				DESIGN BY	
				ALP	
				CHECKED BY	
				JRA/KRR	
				DRAWN BY	
				SDU	
				CHECKED BY	
				JRA/KRR	
				SURVEYED BY	
				OTHERS	
				DRAWING NO.	
				C2.2	
				DATE	
				Mar.28/24	
				SCALE	
				AS NOTED	
				SHEET 3 OF 3	

MTE
Engineers | Scientists | Surveyors
(905) 639-2552 www.mte85.com

NOT FOR CONSTRUCTION

NOTES AND DETAILS PLAN	
Project Manager	Project No.
K. RAMSEWAK	43438-100
Design By	Checked By
ALP	JRA/KRR
Drawn By	Checked By
SDU	JRA/KRR
Surveyed By	Drawing No.
OTHERS	C2.2
Date	
Mar.28/24	
Scale	Sheet 3 of 3
AS NOTED	